

QUALITY YOU CAN COUNT ON.

Inert's line of I-Lab Glovebox Systems are designed as an economical solution for inert research applications. As with all our Gloveboxes, I-Lab Gloveboxes are manufactured using the industry's finest components from globally recognized manufacturers.

### I-LAB 2GB

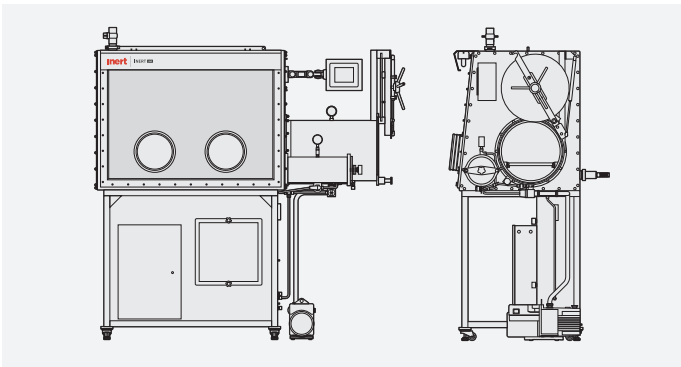

**Internal Dimensions:**  
1213 mm W x 764 mm D x 897 mm H  
**External Dimensions:**  
2005 mm W x 1034 mm D x 2024 mm H

### I-LAB 3GB

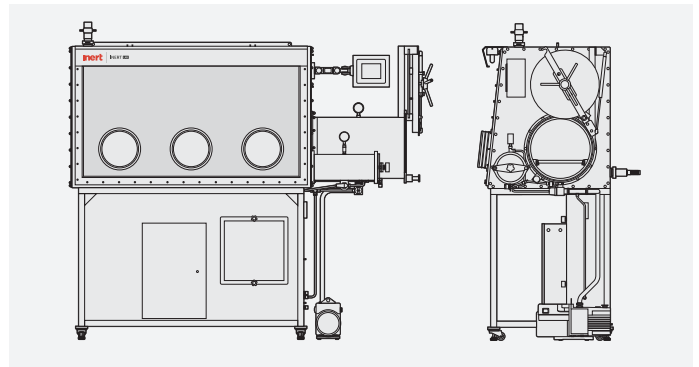

**Internal Dimensions:**  
1524 mm W x 764 mm D x 897 mm H  
**External Dimensions:**  
2316 mm W x 1034 mm D x 2024 mm H

### I-LAB 4GB

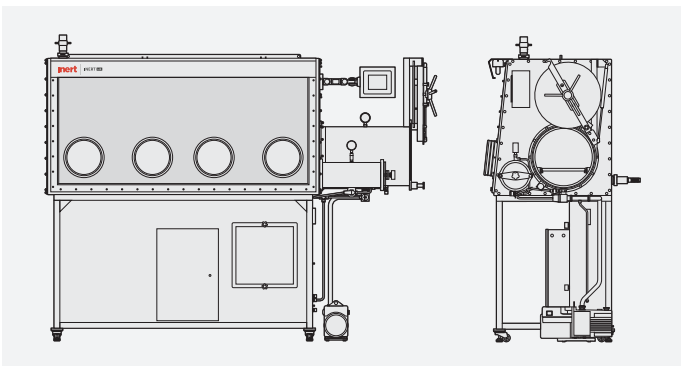

**Internal Dimensions:**  
1803 mm W x 764 mm D x 897 mm H  
**External Dimensions:**  
2595 mm W x 1034 mm D x 2024 mm H

### DESIGN OPTIONS

- Left Sided Antechambers
- Oval Glove Ports
- Safety Glass Window
- Modular
- Dry Vacuum Pump
- Cold Wells
- PureSolv MD Integration

## SPECIFICATIONS

**Internal Finish:** Type 304 stainless steel, #4

**External surfaces:** RAL 7035

**Wall thickness:** 0.105" (2.6 mm)

**Feedthrough:** 4 x DN 40 ISO-KF blank

**Internal Power:** 1 x electrical feedthrough

**Internal Power:** 1 x fuse protected 6 outlet power strip

**Shelving:** 2 x Height adjustable 304 stainless steel #4 finish.

**Plumbing:** 304 stainless steel tubing

**Filters:** 1 x Inlet/ 1 x Outlet HEPA (99.99% vs 0.3 micron MPPS)

**Lighting:** External Fluorescent light

**Power:** 100-120 or 200-240 VAC 50/60 Hz 20 Amp

**Overall System Leak Rate:** <0.05vol%/h (ISO 10648-2)

**Non-modular box design**

**Large Antechamber, 15" (381 mm) internal diameter x 24" (609 mm) internal length**

**Bolt on left or right side**

**Internal tray:** 304 stainless steel #4 surface finish

**Manual evacuate/refill valves**

**Leak rate:** < 10<sup>-5</sup> mbar l/s

**Small Antechamber, 6" (152 mm) internal diameter x 17.3"(441 mm) internal length**

**Manual evacuate/refill valve**

**Leak rate:** < 10<sup>-5</sup> mbar l/s

**Polycarbonate window 3/8" (9.5 mm) thick.**

Viewing size : 41.8" (1061 mm) Wide x 30.2" (767 mm) High

Circular glove ports

0.015" (0.4mm) thick butyl rubber gloves, hand size 9.75

**I-Lab Gas Management System**

Single column system purifies, recirculates, and analyzes inert atmosphere

**<1ppm O<sub>2</sub> and <1ppm H<sub>2</sub>O purity level**

O<sub>2</sub> capacity = 43 L

H<sub>2</sub>O capacity = 1800 g

**Variable speed circulation blower:** 60 cfm max flow rate blower

**Siemens SIMATIC S7-1200 PLC control system**

**Siemens KTP400 4" (101.6 mm) color touch screen HMI**

**Automatic pressure control:** (+/- 15 mbar)

**Manual pressure control:** Footswitch

**Fully automatic regeneration sequence.**

**Manual purge valve**

**Vacuum pump:** 10 cfm (17 m<sup>3</sup>/h) rotary vane pump with oil mist eliminator & oil return kit

**Integrated oxygen analyzer:** Range 0-1000 ppm  
EOS-2 analyzer

**Integrated moisture analyzer:** Range 0-1000 ppm

**Approvals:**



## OPTIONS

- 0-1000 ppm EOS-1 Analyzer
- 0-25% Zirconia Oxygen Analyzer
- 0-1000ppm Moisture Analyzer
- Auto Purge Valve
- Solvent Removal
- Rectangular Freezer: -35°C  
Internal Volume = 20L (40L available)
- Coldwell
- Heat Exchanger
- Dry Scroll Pump
- Electrical Feedthroughs
- Fiberoptic Feedthroughs
- RS-232/USB/Ethernet Feedthroughs
- Binding Posts
- Optical View Ports For Laser Spectroscopy Applications
- Vacuum Ovens
- Solvent Purification Systems
- Microscope Systems - Internal and Window Mounted.
- Vacuum/Gas Feedthroughs
- Custom Feedthroughs
- Numerous Glove Options - Material, Thickness, Hand Size
- Static Eliminator (Benchtop Style)
- Probe Stations
- UV Ozone Cleaners

## SYSTEM APPLICATIONS

- Additive (3D) Manufacturing
- Aerospace
- Automotive
- Chemistry
- Lamp Manufacturing
- Lithium Ion Battery
- Medical Device
- Nuclear
- OLED
- Pharmaceutical
- Semiconductor
- Solar
- Specialty Chemical
- Thin Film
- Many other applications