

EA15-HP50

HEMISPHERICAL ENERGY ANALYSER

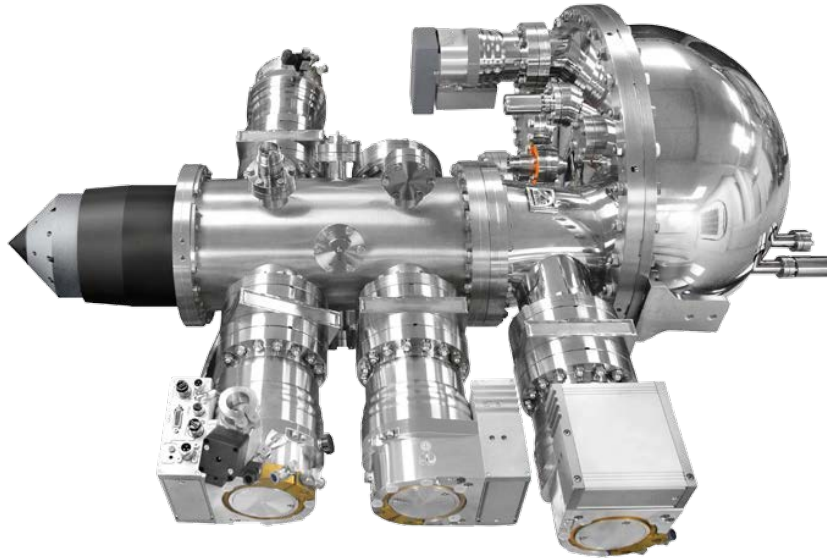

XPS | UPS*

DESCRIPTION

The PREVAC EA15-HP50 hemispherical energy analyser allows due to special designed extraction cones and automatic vacuum control, high-resolution PES measurements in static and dynamic environments **up to 50 mbar**.

Equipped with a total number of 11 slits, the analyser offers the possibility to choose between best energy resolution and best intensity. According to given photoelectron energy the analyser is set up with up to 9 predefined PE to satisfy customer's requirements.

DETECTORS

- **MCP-CCD detector**
 - 40 mm diameter dual MCP detector
 - 656 energy channels available simultaneously
 - 494 angular spatial channels available simultaneously
 - 90 fps
- **7-MCD detector** (for UHV)
- **DLD detector** (for UHV, on request)

ANALYSER PACKAGE

The PREVAC analyser package includes:

- EA15-HP50 hemispherical energy analyser
- RUDI-EA2 high stable and low noise electronics
- SPECTRIUM acquisition and analyser control software with Windows OS computer system.

ADDITIONAL INFORMATION

EA15-HP50 hemispherical energy analyser can be controlled directly by LabVIEW programming environment.

TECHNICAL DATA

Mounting flange	DN 200 CF
Bakeout temperature	up to 120 °C
Working distance	0.3 - 2 mm (dependent on cone opening)
Analyser mean radius	150 mm
Pass energies	5, 10, 20, 50, 100, 200, 250, 300, 500 eV
Energy resolution	XPS < 20 meV FWHM
Kinetic energy range	0.5 - 1500 eV
Acquisition modes	fixed, scan
Lens acceptance angle (transmission mode)	+/- 9°
Maximum energy window in fixed mode	12.5 % of pass energy (for MCP-CCD)
Completely designed of non-magnetic materials	

SPECTRIUM SOFTWARE



* up to 0.1 mbar.

NOTE | The use of a mu-metal analysis vacuum chamber or an inner mu-metal shielded chamber in combination with PREVAC EA15-HP50 analyser is recommended in order to minimize influence of external magnetic fields and to maximize performance of the analyser.



PREVAC sp. z o.o. sales@prevac.eu
Raciborska Str. 61 [+48 32 459 21 30](tel:+48324592130)
PL44362 Rogów [+48 32 459 20 01](tel:+48324592001)

EA15-HP50

www.prevac.eu

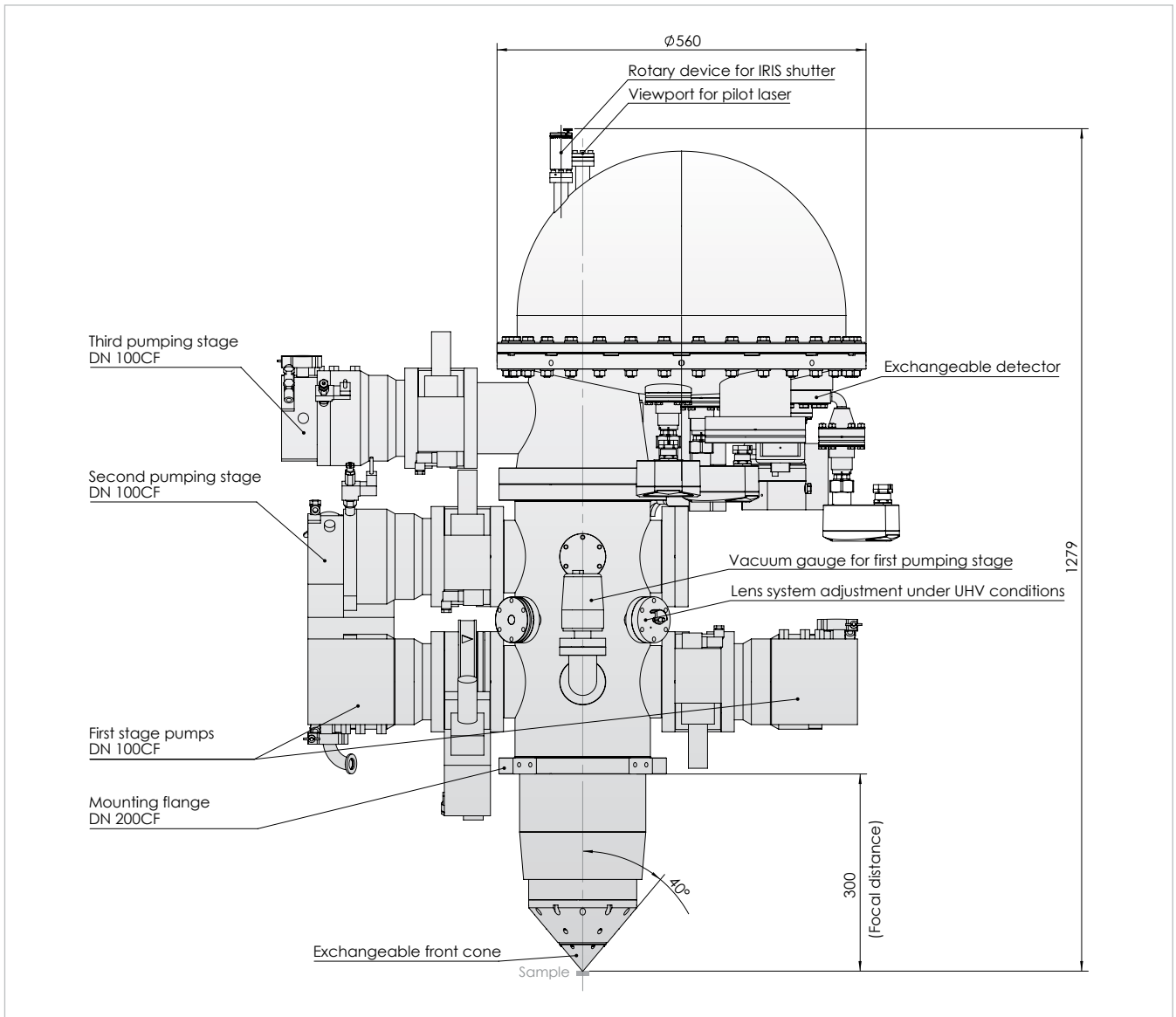

PREVAC sp. z o.o. ✉ sales@prevac.eu
 Raciborska Str. 61 ☎ +48 32 459 21 30
 PL44362 Rogów 📞 +48 32 459 20 01

EA15-HP50