

**FSG-12/16
ADIV Series**

Fully Automatic Precision Surface Grinder

In-machine dynamic balancing

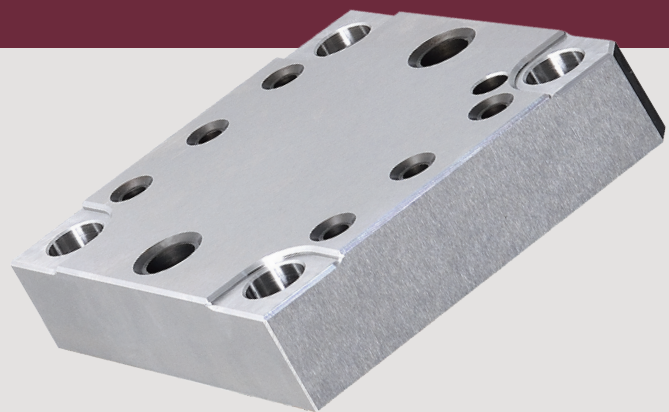

CHEVALIER[®]
Grinding / Turning / Milling

We shape your ideas.™

Introduction

Chevalier's FSG-ADIV Series of surface grinders have several design features to shorten your processing and non-processing preparation while delivering high-precision workpieces year after year—functions you might not expect on such affordable machines: iSurface control, variable speed spindle, constant surface speed, loading detection and in-machine manual dynamic balancing.

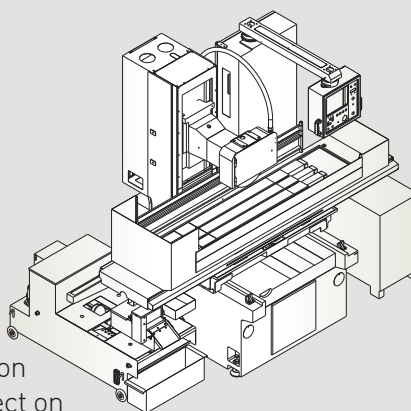

FSG-ADIV Series grinders also feature tools to secure Big Data with Chevalier's exclusive iMachine Communications System™ (iMCS). This software package, combined with data analysis, enhances machine efficiency in the factory while enabling remote monitoring and diagnostics to track machine performance and identify potential problems before they begin.



The FSG-1224ADIV is shown with optional accessories.



Constant surface speed adjusts as the grinding wheel's diameter changes for increased accuracy



iMachine Communications System™ (iMCS) software

This exclusive Chevalier software package remotely collects data and allows managers to track it from any mobile device. (Additional PC and software are required.)



Key Features and Benefits

In-machine dynamic balancing

By manually adjusting the in-machine dynamic balancing function, operators can reduce grinding wheel vibration and eliminate the surface workpiece ripple to improve grinding quality.

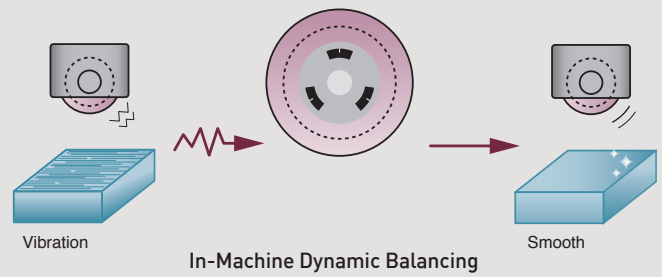

Variable speed spindle

The built-in driver controls spindle speed. Combined with the automatic dressing function, the driver provides constant surface speed regardless of the grinding wheel's changing diameter.

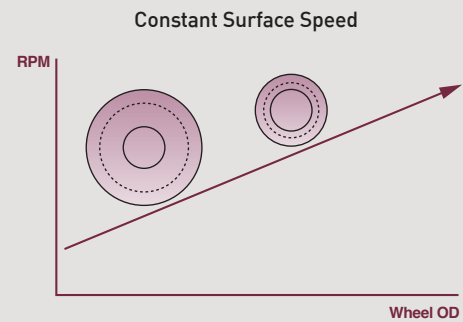

Automatic dressing on table (optional)*

When the grinder enters an automatic dress cycle, the table automatically positions itself where the diamond is set to dress and compensate according to operator settings.

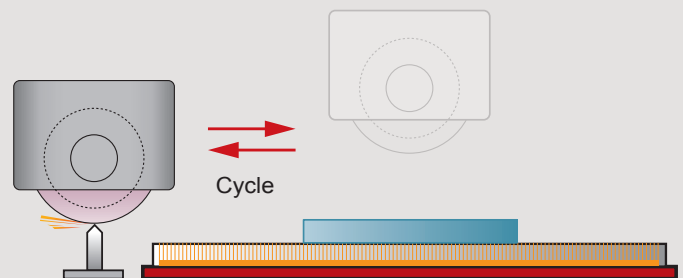

A higher level of precision, flexibility and functionality with in-machine dynamic balancing

Load force detection

Operator can measure the spindle load during the machining cycle, then utilize this data to determine at his or her own discretion whether the wheel requires dressing. If an abnormal load is detected, the spindle automatically moves up to stop the cycle.

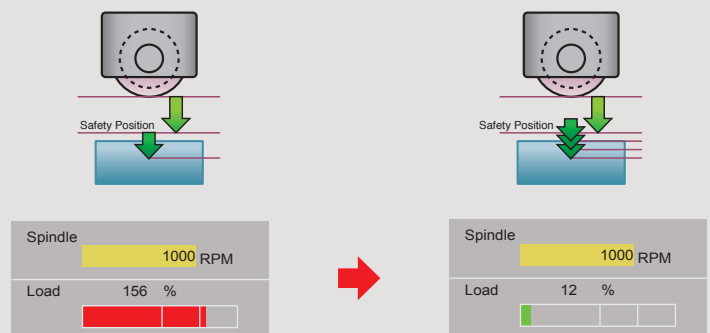

Enhanced control system

Unlike PLC control boards, the PC-based control's powerful computing power enhances the HMI for more precise control. Combined with data analysis from network connectivity, it permits managers to improve production presses for higher output.

*U.S.A. Auto. dressing is standard



Perfect HMI control

The control's standard equipment includes a 10.4" high-color touchscreen with HMI.

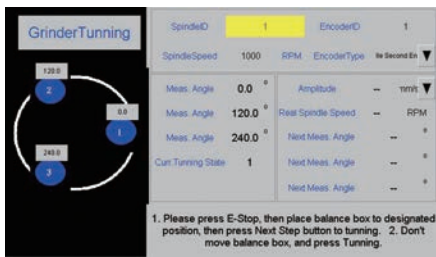

In-Machine Dynamic Balancing

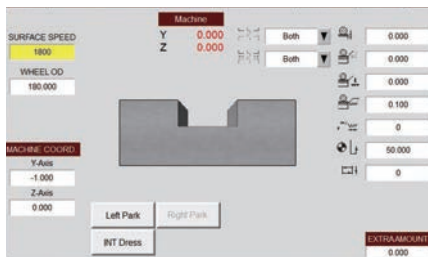

Plunge Grinding Mode

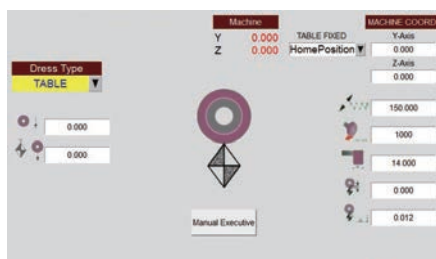

Automatic Dressing on Table (optional)*

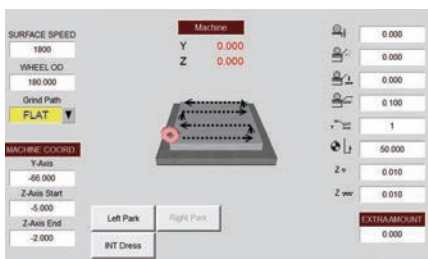

Surface Grinding Mode

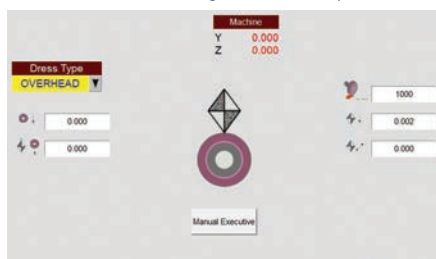

Automatic Overhead Dresser with Compensation (optional)

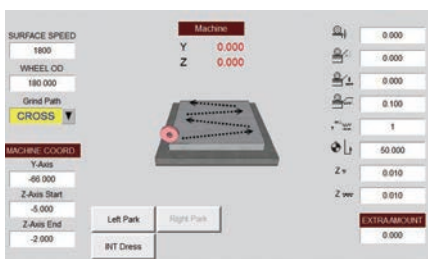

Crisscross Grinding Mode

Control Features and Benefits

All new iSurface control

FSG-ADIV Series controls are PC-based (NC control), high specification industrial units. The high-response AC servo motors on the Y and Z axes are designed to improve accuracy.

The control is equipped with a variable frequency drive system that automatically adjusts the grinding wheel's line speed. A magnetic encoder accurately detects spindle load and correctly grasps the spindle cutting load.

A built-in acceleration gauge monitors the grinding wheel's balance at all times. If the wheel becomes unbalanced the operator will be notified to rebalance the wheel.

Control station

The control station can be adjusted to a comfortable position for the operator. All switches, buttons, LEDs, indicating lamps and displays are ergonomically positioned providing user friendly functionality.



The control's variable frequency drive system automatically adjusts the grinding wheel's line speed



Wheel Dressing

A normal dressing mode wastes time by cutting in air. The iSurface dressing mode never cuts air because the diamond is in constant contact with the wheel to minimize dress time.

Auto dressing modes (optional)*

Conversational graphic automatic wheel dressing modes can be linked with any—or all—grinding modes.



*U.S.A.: standard

The FSG-1632ADIV is shown with optional accessories.

On Table Dressing



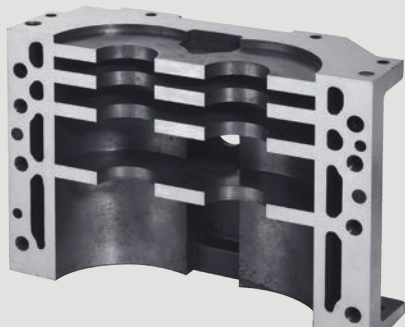
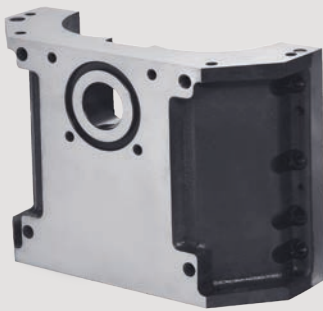
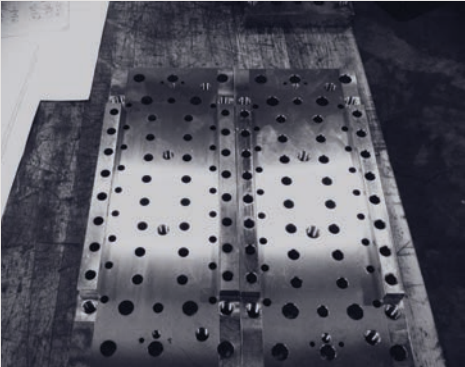
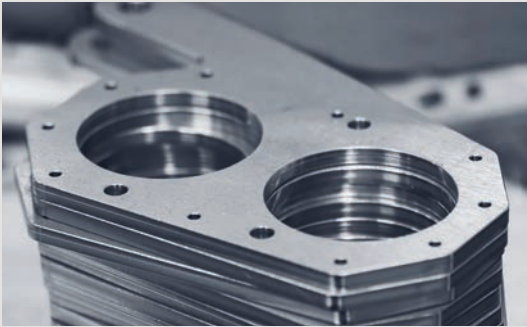
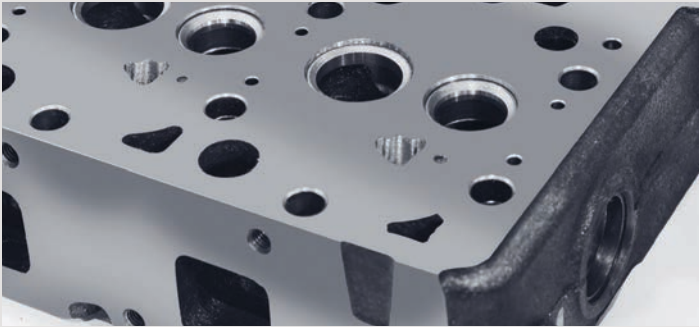

The wheel dressing mode ensures the grinding wheel remains true for consistent grinding accuracy

Applications

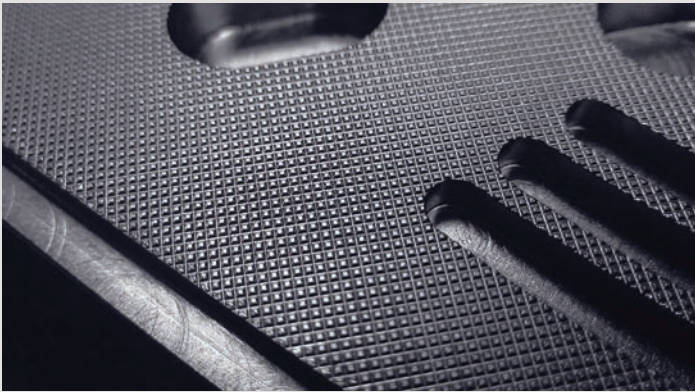
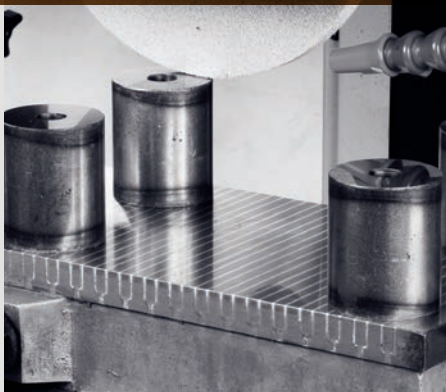
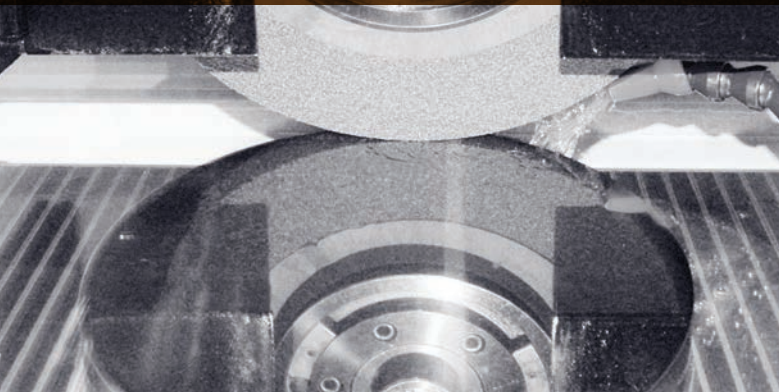

The FSG-ADIV Series has built-in long-term value in process-based applications





FSG-ADIV Series is ideal for job shops, as well as the aerospace and construction industries

Machine Construction

Wheelhead and column system

FSG-ADIV Series wheelhead and column system is composed of hardened and ground steel guideways with inserted roller bearings. This system is preloaded which imparts zero clearance for precise straight movement, accurate feeds and precise linear movement without deviation, even during rapid traverse movement.

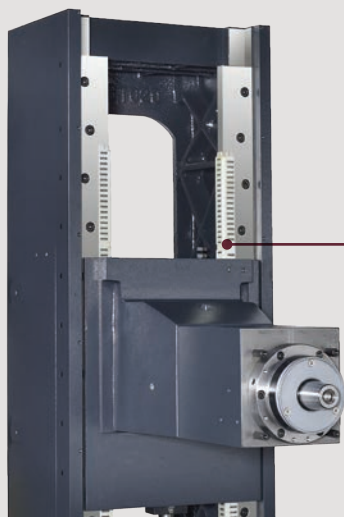

Low friction wheelhead guideway system enables accurate feeds even at 0.001 mm (0.00001") increments.

Completely supported guideways

The series includes extended base guideways for crossfeed and longitudinal travel to enhance rigidity and stability, upgrade accuracy and longevity and eliminate table overhang to completely support permissible loads.

The guideway rails are composed of (S55C) steel, normalized and hardened by high frequency induction. The heat treated roller bearings are preloaded between the linear guideways, ensuring accurate positioning, free of stick-slip movement.

AC servo motor

The AC motor provides high torque, speed and accurate positioning with minimum increments of 0.001 mm (0.00001"). A manual pulse generator (MPG) is included for ease of operation.

The cross-feed speed is controlled by the AC servo motor for better surface finish, precise movement and wheel dressing from the table.

3-axis linear roller guideways enhance rigidity and stability for cross-feed and longitudinal travel



Precision roller bearings run through a matching sleeve, which is preloaded between the linear guideways to ensure accurate and precise positioning with stick-slip free movement.

Max. Working Space

Units: mm (")

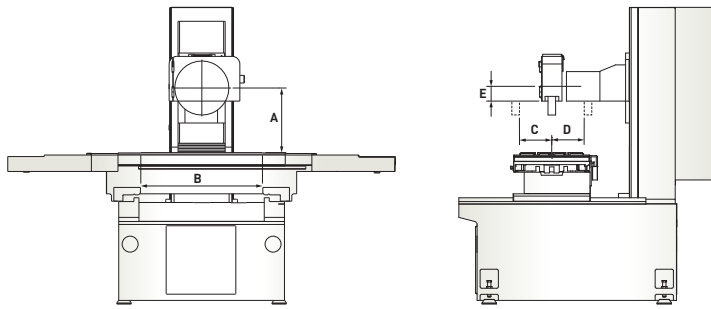

Item	A	B	C	D	E
FSG-1224ADIV	610 (24)	610 (24)	152.5 (6)	152.5 (6)	86 (3.4)
FSG-1632ADIV	610 (24)	810 (32)	202.5 (8)	202.5 (8)	86 (3.4)
FSG-1640ADIV	610 (24)	1,015 (40)	202.5 (8)	202.5 (8)	86 (3.4)

Table and T-Slot Dimensions

Units: mm (")

FSG-1224ADIV

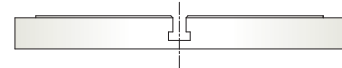

FSG-1632ADIV

FSG-1640ADIV

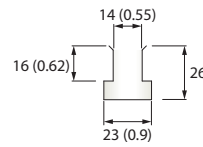
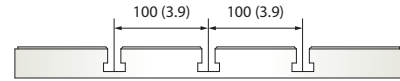

FSG-1224ADIV	T-slot x 1
FSG-1632ADIV	T-slot x 3
FSG-1640ADIV	T-slot x 3

Machine Dimensions

Units: mm (")

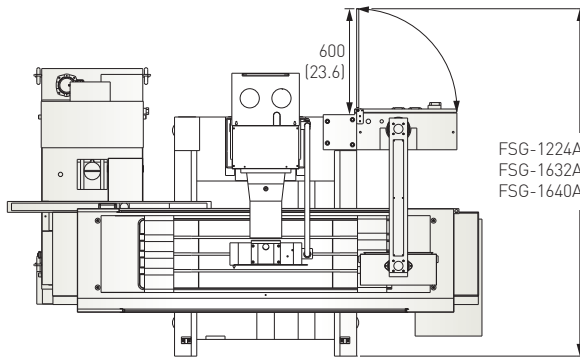

FSG-1224ADIV: 1,850 (72.8)
FSG-1632ADIV: 2,080 (81.9)
FSG-1640ADIV: 2,080 (81.9)

FSG-1224ADIV: 2,950 (116.1)
FSG-1632ADIV: 3,540 (139.4)
FSG-1640ADIV: 4,280 (168.5)

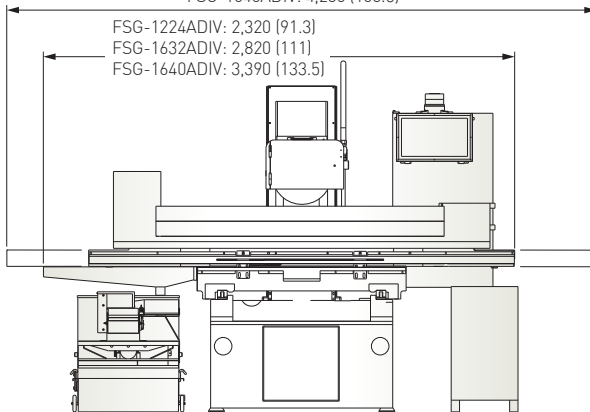

FSG-1224ADIV: 2,320 (91.3)
FSG-1632ADIV: 2,820 (111)
FSG-1640ADIV: 3,390 (133.5)

FSG-1224ADIV: 940 (37)
FSG-1632ADIV: 1,090 (42.9)
FSG-1640ADIV: 1,600 (63)

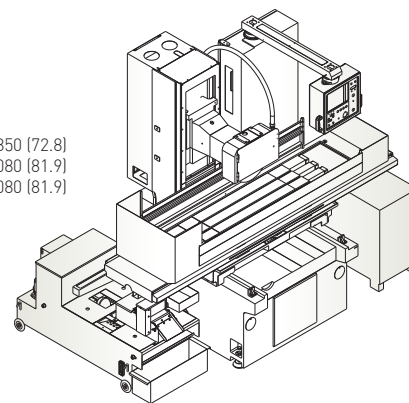

Note: Machine shown with optional accessories

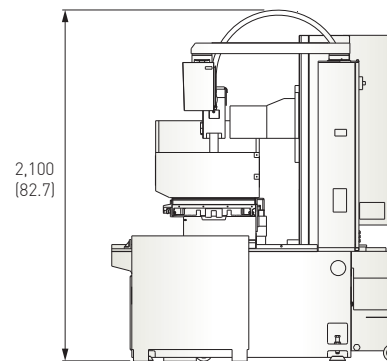

Loading Capacity

Item	FSG-1224ADIV	FSG-1632ADIV	FSG-1640ADIV
A	145 kg (319 lbs.)	175 kg (385 lbs.)	220 kg (484 lbs.)
B	85 kg (187 lbs.)	175 kg (385 lbs.)	220 kg (484 lbs.)
C	230 kg (506 lbs.)	350 kg (770 lbs.)	440 kg (968 lbs.)

Suggested maximum table loads
A = Workpiece, B = Chuck, C = A+B

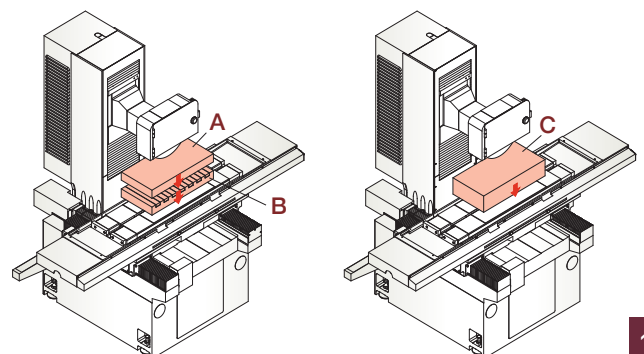



A full line of standard and optional accessories adds flexibility to FSG-ADIV Series grinders

Accessories

Standard accessories

- Wheel flange (optional reserve wheel flanges available):
Clamping width 19~38 mm (0.7" ~ 1.5")
- Grinding wheel (OD x Width x Bore):
Ø355 x 50 x Ø127 mm (Ø14" x 2" x Ø5")
- Splash guard
- Stylus
- Heat exchanger for electric cabinet
- Leveling pads:
FSG-1224/1632ADIV: 4 pieces,
FSG-1640ADIV: 6 pieces
- Leveling screw and nuts:
FSG-1224/1632ADIV: 4 sets,
FSG-1640ADIV: 6 sets
- Toolbox (includes balancing arbor, wrench, hex head wrench, diamond dresser with diamond)

Optional accessories

- Chuck control
- Electromagnetic chuck
- Diamond dresser
- 7.5 HP spindle motor
- Coolant system with auto paper feeding device
- Coolant system with auto paper feeding device and magnetic separator
- Hydraulic oil tank chiller
- Over-the-wheel automatic straight-line dressing and compensation device
- Y/Z axis linear scale
- Parallel dressing attachment (hydraulic type)
- Automatic table dresser with compensation (includes special hydraulic oil tank*)
- Double-sided water baffle
- Guideway-type balancing stand (12/16 series)
- Work lamp

Specifications

Item	Description	FSG-1224ADIV	FSG-1632ADIV	FSG-1640ADIV
Control system			iSurface	
Capacity	Max. grinding length-longitudinal	610 mm (24")	810 mm (32")	1,015 mm (40")
	Max. grinding width-crosswise	305 mm (12")	405 mm (15.9")	405 mm (15.9")
	Distance between table to spindle centerline		610 mm (24")	
	Height from table to ground	970 mm (38.2")		980 mm (38.6")
	Max. table load	230 kg (506 lbs.)	350 kg (770 lbs.)	440 kg (968 lbs.)
Table	Table size	300 x 600 mm (11.8" x 23.6")	400 x 800 mm (15.7" x 31.5")	400 x 1,000 mm (15.7" x 39.4")
	T-slots (width x pitch x no.)	14 mm x 150 mm x 1 (0.6" x 5.9" x 1)	14 mm x 100 mm x 3 (0.6" x 3.9" x 3)	14 mm x 100 mm x 3 (0.6" x 3.9" x 3)
	Table speed (variable)		5-25 m/min (16-82 fpm)	
	Max. table travel	Hydraulic 650 mm (25.6")	Hydraulic 850 mm (33.4")	Hydraulic 1,050 mm (41.3")
Transverse movement (Z)	Max. travel	350 mm (13.8")		450 mm (17.7")
	Feed speed		0-2,250 mm/min (0-7.38 fpm)	
	Automatic transverse movement (step)		0.001-32 mm (0.00001"-1.3")	
	Min. input		0.001 mm (0.00001")	
Wheelhead movement (Y)	Max. travel		480 mm (18.9")	
	Feed speed		0-675 mm/min (0-2.2 fpm)	
	Automatic elevating movement (step)		0.001-0.04 mm (0.00001"-0.0016")	
	Min. input		0.001 mm (0.00001")	
Spindle	Spindle speed		500-1,800 rpm	
	Spindle motor		3.75 kW (5 HP) Opt. 5.5 kW (7.5 HP)	
Motors	Axis motors (Y/Z)		Y: AC servo 1.1 kW/ Z: AC servo 1.1 kW	
	Hydraulic motor	0.74 kW (1 HP) / 6P		1.5 kW (2 HP) /6P
Wheel dimension	OD x Width x Bore	Ø355 x 50 x Ø127 mm (Ø14" x 2" x Ø5")		
Power and air requirement	Power required	9 kVA (11.5 kVA optional)	10 kVA (12.5 kVA optional)	
Machine dimensions	Floor space (W x D x H)	2,950 x 1,470 x 2,100 mm (116" x 57.9" x 82.7")	3,540 x 1,700 x 2,100 mm (139.4" x 66.9" x 82.7")	4,280 x 1,700 x 2,100 mm (168.5" x 66.9" x 82.7")
	Net weight	2,200 kg (4,850 lbs.)	2,900 kg (6,390 lbs.)	3,500 kg (7,710 lbs.)
Accuracy	Accuracy standard	ISO 1986-1		

All content is for reference only and may be subject to change without prior notice or obligation.



Grinding
Machines

SMART
Grinding Machines

Turning
Machines

Milling
Machines

CHEVALIER[®]
Grinding / Turning / Milling

We shape your ideas.[™]

Headquarters
FALCON MACHINE TOOLS CO., LTD.
No. 34, Hsing Kong Road, Shang Kang, Chang Hua
TAIWAN 50971
Tel: +886 4 799 1126 Fax: +886 4 798 0011
▶ www.chevalier.com.tw
▶ overseas@chevalier.com.tw

U.S.A. Headquarters
CHEVALIER MACHINERY INC.
9925 Tabor Place, Santa Fe Springs, CA 90670 U.S.A.
Tel: (562) 903 1929 Fax: (562) 903 3959
▶ www.chevalierusa.com
▶ info@chevalierusa.com