

GENERAL CATALOG

/// Taiwan TAKISAWA Technology Co., Ltd.

Pingchen /
No. 505, Sec 3, Yenping Rd., Pingchen Dist.,
Taoyuan City 324, Taiwan
TEL: +886-3-4643166 FAX: +886-3-4642614

Yangmei /
No. 89, Sec. 1, Meishi Rd., Yangmei Dist.,
Taoyuan City 326, Taiwan
TEL.: +886-3-4813119 FAX: +886-3-4813185
E-mail: callcenter@takisawa.com.tw

/// Shanghai TAKISAWA Mechatronics Ltd.

Shanghai /
No. 1568, Yuanguo Road, Anting Town,
Jiading District, Shanghai
TEL: +86-21-59562955 FAX: +86-21-59562956

/// TAKISAWA Tech Corp

U.S.A /
15271 Fairfield Ranch Rd., Unit 130,
Chino Hills, CA 91709, U.S.A
TEL: +1-866-606-6143 / +1-909-308-0903
E-mail: joshua.huang@takisawatechcorp.com

/// TAKISAWA Tech Asia Co.,Ltd.

Thailand /
18/31 M.7, Bangchalong, Bangphi,
Samutprakan, 10540, Thailand
TEL: +66-20465900 FAX: +66-20465901
E-mail: nuttapong@takisawa.com

/// www.takisawa.com.tw

/// Horizontal Turning Center

Classic

NEX

NEX-105 / NEX-106 / NEX-108 / NEX-110

Compact

LA

LA-150 / LA-200

High Performance

LA

LA-250 / LA-300 / LA-250YS / LA-250YT

Heavy Duty

LA

LA-350 / LA-450

Extra Heavy Duty

LS

LS-800 / LS-1000 / LS-1100

High Accuracy

LX / EX

EX-2000 / LX-2500 / LX-3000

High Productivity with Twin Turrets

MX / FX

MX-800 / FX-600 / FX-800

/// Vertical Turning Center

Heavy Duty

VTL

VTL-350 / VTL-450 / VTL-750A / VTL-760 / VTL-950 / VTL-1100

Inverted Vertical

YC

YC-108 / YC-308 / YC-110 / YC-310 / YC-120



Manufacturing to Win Customer's Confidence

Taiwan Takisawa inherits the 100-years skillful technical art for machine tool manufacturing, and sharing R&D technology with integration of resources from Japan Takisawa.

Taiwan Takisawa concentrates on the research and development of CNC lathe and continuous evolution and improvement from shortening the product design cycle and highly customized products.

Moreover, the new machine design is with high complex and implemented with many intelligent functions which has been formulated a new standard for a new generation of products. In general, the new generation of products provide unparalleled manufacturing flexibility and customer-oriented with complete process solutions.

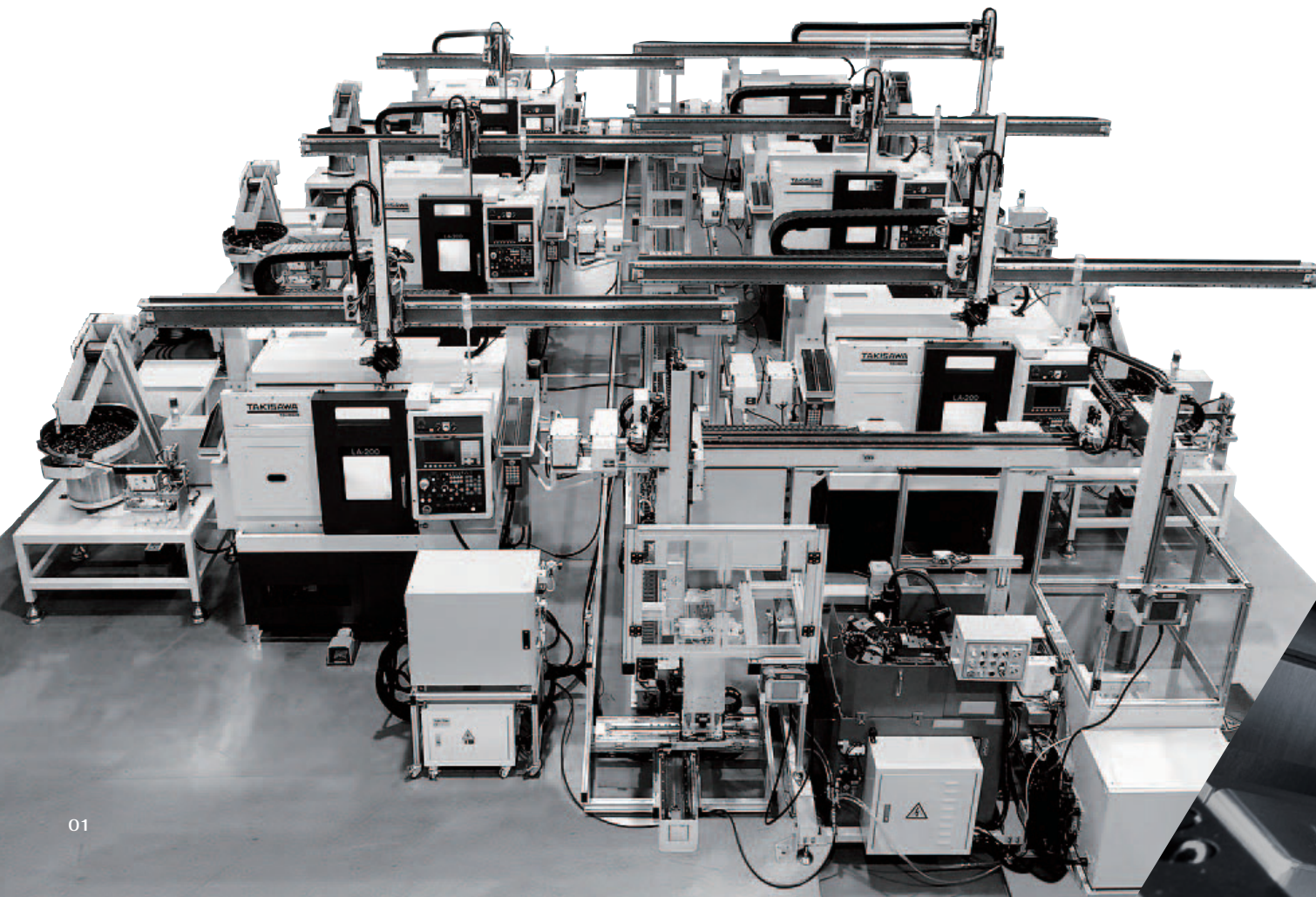

Product Full Line-up



Horizontal Turning Center

Classic

5" ~ 10"

NEX series	NEX-105	5"	STD	K					
	NEX-106	6"	STD	K					
	NEX-108	8"	STD	H	M	MH	Y	YH	
	NEX-110	10"	STD	H	M	MH	Y	YH	

Compact

6" ~ 8"

LA-150 / 200 series	LA-150	6"	STD	M	L	ML			
	LA-200	8"	STD	M	L	ML			

High Performance

10" ~ 12"

LA-250 / 300 series	LA-250	10"	STD	M	Y	L	ML	YL
	LA-300	12"	STD	M	Y			
	LA-250YS	10"	STD					
	LA-250YT	10"	STD					

Heavy Duty

12" ~ 18"

LA-350 / 450 series	LA-350	12"	STD	L8 ML8	L16 ML16	L22 ML22		
	LA-450	18"	STD	L8 ML8	L16 ML16	L22 ML22		

Extra Heavy Duty

15" ~ 32"

LS series	LS-800	15"	STD	BL10	BL15	BL20	BL30
				MBL10	MBL15	MBL20	MBL30
				YBL10	YBL20	YBL30	
	18"	STD	CL10	CL15	CL20	CL30	
			MCL10	MCL15	MCL20	MCL30	
			YCL10	YCL20	YCL30		
LS-1000	20"	STD	L10	L15	L20	L30	
			ML10	ML15	ML20	ML30	
LS-1100	32"	STD	L20	L30	L40		



High Accuracy

8" ~ 12"

EX-2000 series	EX-2000	8"	T	MT	S	MS	YT	YS
	LX series	LX-2500	10"	STD	L7 ML7 YL7	L13 ML13 YL13	L20 ML20 YL20	
LX-3000		12"	STD	L7 ML7 YL7	L13 ML13 YL13	L20 ML20 YL20		

High Productivity with Twin Turrets

6" ~ 8"

MX / FX series	MX-800	8"	STD	M2	Y	Y2
	FX-600	6"				
	FX-800	8"				

Vertical Turning Center

Heavy Duty

12" ~ 32"

VTL series	VTL-350	12"	R			
	VTL-450	12"	R	MR	L	ML
	VTL-750	24"	A			
	VTL-760	15"	R	MR	L	ML
	VTL-950	32"	R	MR		
	VTL-1100	32"	R	MR		

Inverted Vertical

8" ~ 12"

YC series	YC-108	8"	STD		
	YC-308	8"	STD		
	YC-110	10"	STD		
	YC-310	10"	STD		
	YC-120	12"	STD		

High Accuracy Classic Turning Center

NEX series

- NEX-105, NEX-105K
- NEX-106, NEX-106K
- NEX-108, NEX-108H, NEX-108M, NEX-108MH, NEX-108Y, NEX-108YH
- NEX-110, NEX-110H, NEX-110M, NEX-110MH, NEX-110Y

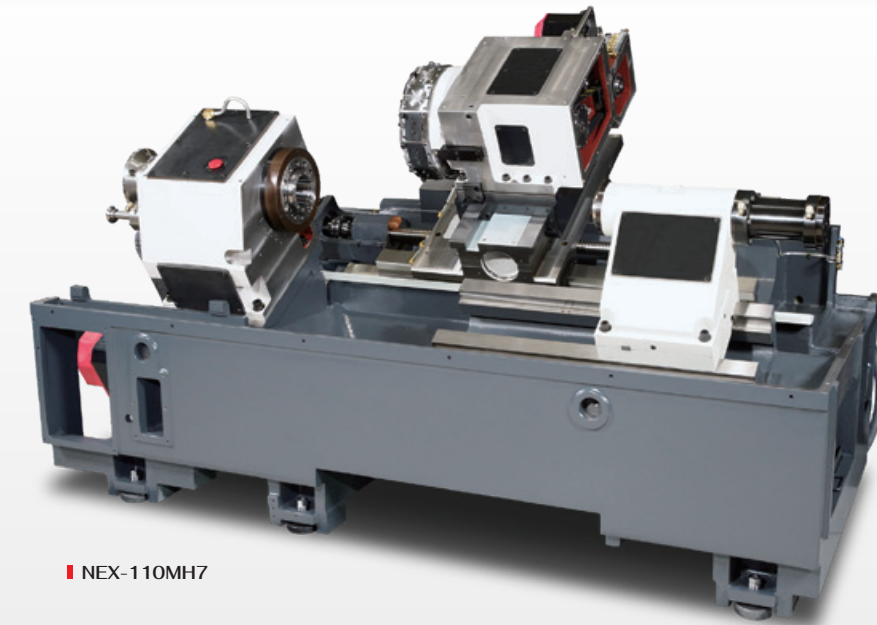

■ NEX-110MH7



■ NEX-110MH7



■ NEX-108Y



■ NEX-108

Specifications

	NEX-105	NEX-105K	NEX-106	NEX-106K	NEX-108	NEX-108H	NEX-108M	NEX-108MH	NEX-108Y	NEX-110	NEX-110H7	NEX-110M	NEX-110MH7	NEX-110Y
Max. Swing	12.20	18.11	13.78	4.33	15.75	18.90	18.90	18.90	18.90	19.49	19.49	19.49	19.49	19.49
Max. Turning Diameter	8.66 (T8) / 6.69 (T12)	4.72	9.45	--	12.60	12.60	10.24	10.24	10.24	15.75	15.75	13.78	13.78	13.78
Max. Turning Length	7.32	3.54	12.60	12.80	18.98	18.98	17.59	17.59	17.54	26.26	26.26	24.89	24.89	24.90
Max. Bar Work Capacity	1.65	1.02 (1.65)	1.69	1.69	2.05 (2.56)	2.05 (2.56)	2.05 (2.56)	2.05 (2.56)	2.05 (2.56)	2.95	2.95	2.95	2.95	2.95
Spindle Speed	6000	5000 (6000)	5000 (6000)	5000 (6000)	3500 (4000)	3500 (4000)	3500 (4000)	3500 (4000)	3500 (4000)	3500	3500	3500	3500	3500
Chuck Size	6"	(5") 6"	6"	6"	8"	8"	8"	8"	8"	10"	10"	10"	10"	10"
Number of Tools	T8 (T12)	Gang Type	T12	Gang Type	T10 (T12)	T10 (T12)	T12	T12	T12	T10	T10	T12	T12	T12
Number of Spindles	1	1	1	1	1	1	1	1	1	1	1	1	1	1

High Performance Compact Turning Center

LA-150/200 series

LA-150, LA-150M, LA-150L, LA-150ML
LA-200, LA-200M, LA-200L, LA-200ML



LA-200M



LA-200M

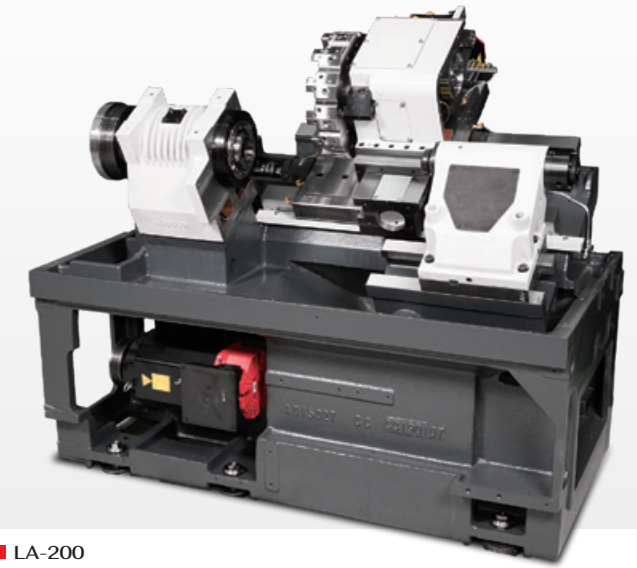

LA-200



LA-200M



LA-200M

Specifications

	LA-150	LA-150L	LA-150M	LA-150ML	LA-200	LA-200L	LA-200M	LA-200ML
Max. Swing	18.50	18.50	18.50	18.50	18.50	18.50	18.50	18.50
Max. Turning Diameter	9.84 (T8) / 12.6 (T10) / 12.6 (T12)	9.84 (T8) / 12.6 (T10) / 12.6 (T12)	9.84	9.84	9.84 (T8) / 12.6 (T10) / 12.6 (T12)	9.84 (T8) / 12.6 (T10) / 12.6 (T12)	9.84	9.84
Max. Turning Length	12.91	24.72	12.32	24.13	11.81	23.62	11.18	22.99
Max. Bar Work Capacity	1.65	1.65	1.65	1.65	2.05 / 2.6	2.05 / 2.6	2.05 / 2.6	2.05 / 2.6
Spindle Speed	5000	5000	5000	5000	3200 (4000)	3200 (4000)	3200 (4000)	3200 (4000)
Chuck Size	6"	6"	6"	6"	8"	8"	8"	8"
Number of Tools	T8 / T10 / T12	T8 / T10 / T12	T12	T12	T8 / T10 / T12	T8 / T10 / T12	T12	T12
Number of Spindles	1	1	1	1	1	1	1	1

High Performance Turning Center

LA-250/300 series

- LA-250, LA-250M, LA-250Y, LA-250L, LA-250ML, LA-250YL
- LA-300, LA-300M, LA-300Y
- LA-250YS
- LA-250YT



LA-250M



LA-250M

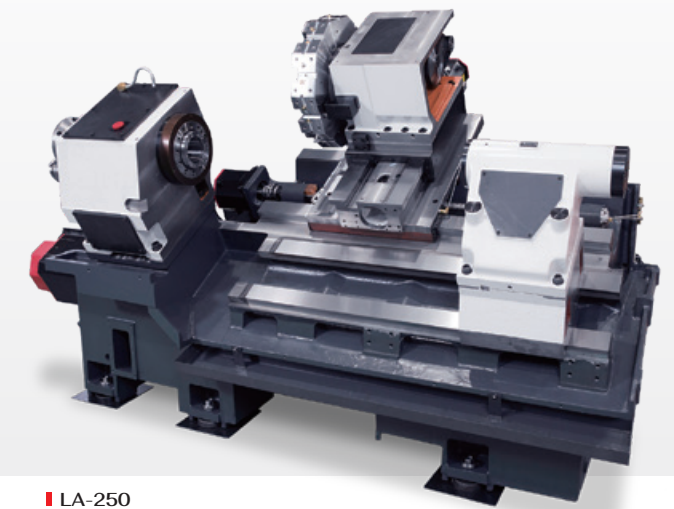

LA-250

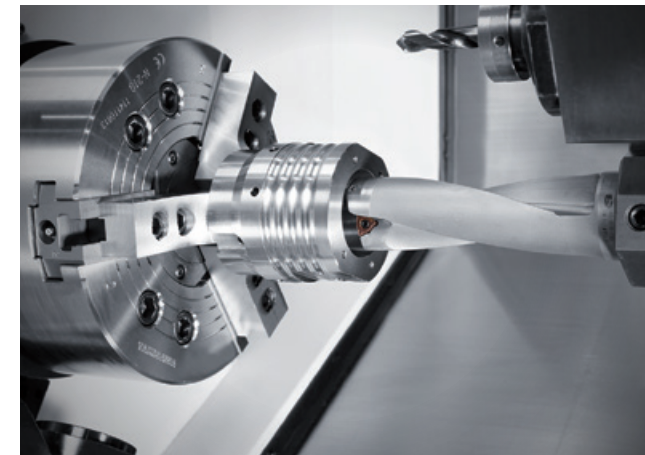

LA-250YL

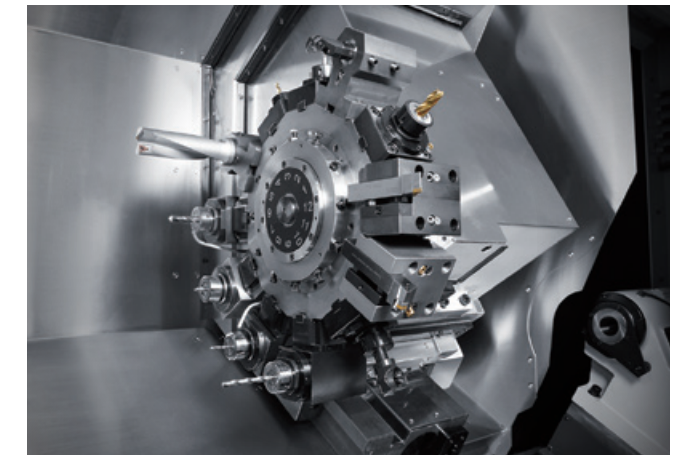

LA-250YL

Specifications

	LA-250	LA-250M	LA-250Y	LA-250L	LA-250ML	LA-250YL	LA-300	LA-300M	LA-300Y	LA-250YS	LA-250YT
Max. Swing	22.83	22.83	22.83	22.83	22.83	22.83	22.83	22.83	22.83	23.62	23.62
Max. Turning Diameter	17.72	16.54	13.78	17.72	16.54	13.78	17.72	16.54	13.78	14.57	14.57
Max. Turning Length	30.2 (P) / 28.23 (G)	28.86 (P) / 26.89 (G)	29.37 (P) / 27.4 (G)	45.94 (P) / 43.98 (G)	44.6 (P) / 42.64 (G)	45.12 (P) / 43.15 (G)	42.76	41.42	41.93	29.02	29.53
Max. Bar Work Capacity	2.95	2.95	2.95	2.95	2.95	2.95	3.54	3.54	3.54	2.95 / 2.05	2.95 (3.19)
Spindle Speed	3500	3500	3500	3500	3500	3500	2800	2800	2800	3500	3500
Chuck Size	10"	10"	10"	10"	10"	10"	12"	12"	12"	10"	10"
Number of Tools	T10 / T12	T12	T12	T10 / T12	T12	T12	T10 / T12	T12	T12	T15 (T12)	T15 (T12)
Number of Spindles	1	1	1	1	1	1	1	1	1	1	1

* P : P Motor / G : Gear Box

* P : P Motor / G : Gear Box

Heavy Duty Turning Center

LA-350/450 series

- LA-350L8
- LA-350ML8
- LA-350L16
- LA-350ML16
- LA-350L22
- LA-350ML22

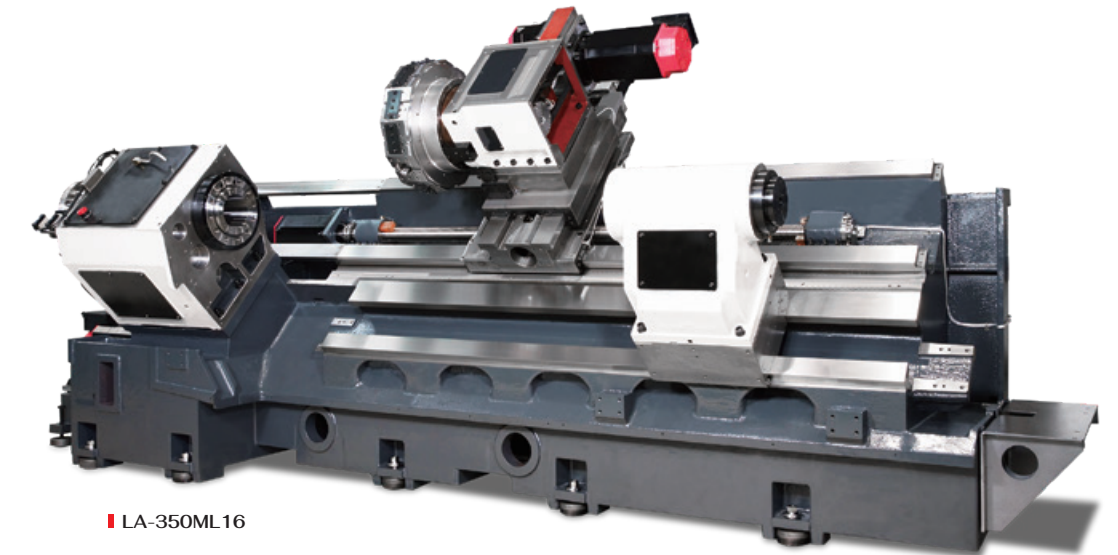
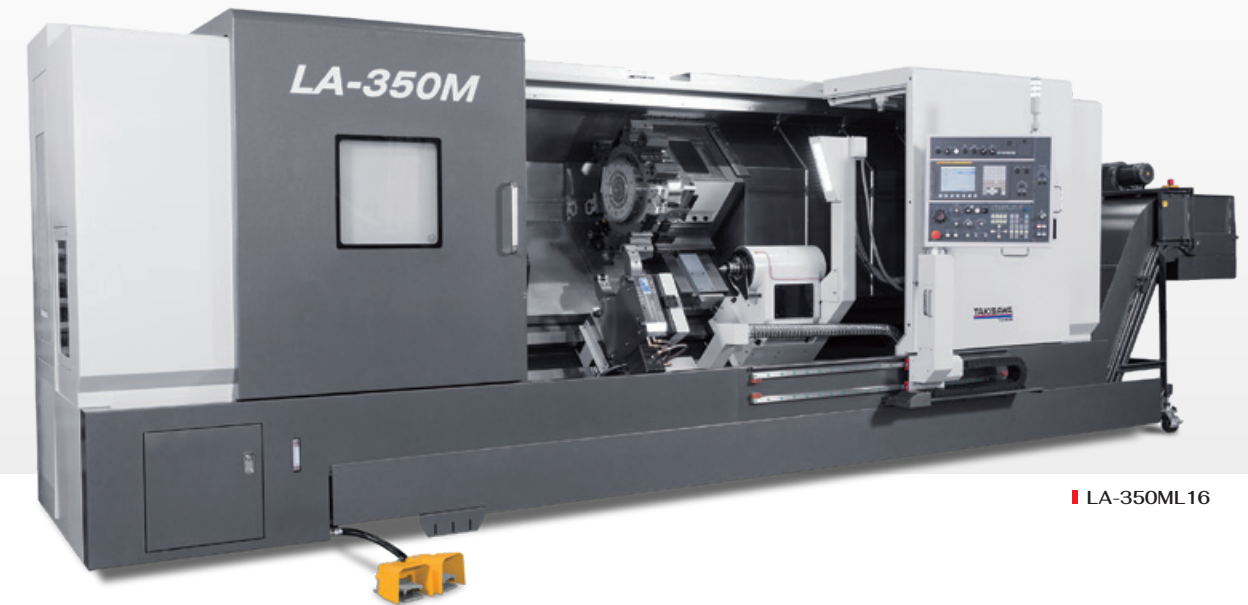

Specifications

	LA-350L8	LA-350L16	LA-350L22	LA-350ML8	LA-350ML16	LA-350ML22	LA-450L8	LA-450L16	LA-450L22	LA-450ML8	LA-450ML16	LA-450ML22
Max. Swing	30.71	30.71	30.71	30.71	30.71	30.71	30.71	30.71	30.71	30.71	30.71	30.71
Max. Turning Diameter	21.65	21.65	21.65	18.90	18.90	18.90	21.65	21.65	21.65	18.90	18.90	18.90
Max. Turning Length	32.68	64.17	89.37	27.99	59.49	84.69	30.75	62.24	87.44	26.06	57.56	82.76
Max. Bar Work Capacity	4.53	4.53	4.53	4.53	4.53	4.53	5.91	5.91	5.91	5.91	5.91	5.91
Spindle Speed	2500 (2000)	2500 (2000)	2500 (2000)	2500 (2000)	2500 (2000)	2500 (2000)	1800 (1500)	1800 (1500)	1800 (1500)	1800 (1500)	1800 (1500)	1800 (1500)
Chuck Size	12" (15")	12" (15")	12" (15")	12" (15")	12" (15")	12" (15")	18" (20")	18" (20")	18" (20")	18" (20")	18" (20")	18" (20")
Number of Tools	T10/T12	T10/T12	T10/T12	T12	T12	T12	T10/T12	T10/T12	T10/T12	T12	T12	T12
Number of Spindles	1	1	1	1	1	1	1	1	1	1	1	1

Extra Heavy Duty Turning Center

LS series

- LS-800B (L10 / L15 / L20 / L30)
- LS-800C (L10 / L15 / L20 / L30)
- LS-800MB (L10 / L15 / L20 / L30)
- LS-800MC (L10 / L15 / L20 / L30)
- LS-800YB (L10 / L20 / L30)
- LS-800YC (L10 / L20 / L30)
- LS-1000 (L10 / L15 / L20 / L30)
- LS-1000M (L10 / L15 / L20 / L30)
- LS-1100 (L20 / L30 / L40)



LS-1000L20



LS-1000L20

Specifications

	B-type				C-type				B-type				C-type			
	LS-800BL10	LS-800BL15	LS-800BL20	LS-800BL30	LS-800CL10	LS-800CL15	LS-800CL20	LS-800CL30	LS-800MBL10	LS-800MBL15	LS-800MBL20	LS-800MBL30	LS-800MCL10	LS-800MCL15	LS-800MCL20	LS-800MCL30
Max. Swing	32.68	32.68	32.68	32.68	32.68	32.68	32.68	32.68	32.68	32.68	32.68	32.68	32.68	32.68	32.68	32.68
Max. Turning Diameter	29.92	29.92	29.92	29.92	29.92	29.92	29.92	29.92	26.77	26.77	26.77	26.77	26.77	26.77	26.77	26.77
Max. Turning Length	43.29	62.97	82.66	122.03	41.32	61.00	80.69	120.06	38.87	58.56	78.24	117.61	36.90	56.59	76.27	115.64
Max. Bar Work Capacity	4.53	4.53	4.53	4.53	7.09	7.09	7.09	7.09	4.53	4.53	4.53	4.53	7.09	7.09	7.09	7.09
Spindle Speed	2000 (1500)	2000 (1500)	2000 (1500)	2000 (1500)	1200	1200	1200	1200	2000 (1500)	2000 (1500)	2000 (1500)	2000 (1500)	1200	1200	1200	1200
Chuck Size	15" (18")	15" (18")	15" (18")	15" (18")	20"	20"	20"	20"	15" (18")	15" (18")	15" (18")	15" (18")	20"	20"	20"	20"
Number of Tools	T10 (T12)	T10 (T12)	T10 (T12)	T10 (T12)	T10 (T12)	T10 (T12)	T10 (T12)	T10 (T12)	T12	T12	T12	T12	T12	T12	T12	T12
Number of Spindles	1	1	1	1	1	1	1	1	1	1	1	1	1	1	1	1

	B-type			C-type			LS-1000L10	LS-1000L15	LS-1000L20	LS-1000L30	LS-1000ML10	LS-1000ML15	LS-1000ML20	LS-1000M/L30	LS-1100L20	LS-1100L30	LS-1100L40
	LS-800YBL10	LS-800YBL20	LS-800YBL30	LS-800YCL10	LS-800YCL20	LS-800YCL30											
Max. Swing	32.68	32.68	32.68	32.68	32.68	32.68	40.16	40.16	40.16	40.16	40.16	40.16	40.16	40.16	44.09	44.09	44.09
Max. Turning Diameter	23.62	23.62	23.62	23.62	23.62	23.62	35.43	35.43	35.43	35.43	33.46	33.46	33.46	33.46	35.43	35.43	35.43
Max. Turning Length	36.43	75.79	115.17	34.46	73.83	113.20	40.62	60.30	79.99	119.36	38.06	57.74	77.43	116.80	83.66	119.09	176.18
Max. Bar Work Capacity	4.53	4.53	4.53	7.09	7.09	7.09	7.09	7.09	7.09	7.09	7.09	7.09	7.09	7.09	8.07	8.07	8.07
Spindle Speed	2000 (1500)	2000 (1500)	2000 (1500)	1200	1200	1200	1200	1200	1200	1200	1200	1200	1200	1200	900	900	900
Chuck Size	15" (18")	15" (18")	15" (18")	20"	20"	20"	20" (24")	20" (24")	20" (24")	20" (24")	20" (24")	20" (24")	20" (24")	20" (24")	24" (28") (32")	24" (28") (32")	24" (28") (32")
Number of Tools	T12	T12	T12	T12	T12	T12	T10 (T12)	T10 (T12)	T10 (T12)	T10 (T12)	T12	T12	T12	T12	T10	T10	T10
Number of Spindles	1	1	1	1	1	1	1	1	1	1	1	1	1	1	1	1	1

High Accuracy Y-axis Turning Center

LX series

— LX-2500, LX-2500M, LX-2500Y
LX-3000, LX-3000M, LX-3000Y
LX-2500L12, LX-2500ML12, LX-2500YL12
LX-3000L12, LX-3000ML12, LX-3000YL12

LX-2500L20, LX-2500ML20, LX-2500YL20
LX-3000L20, LX-3000ML20, LX-3000YL20

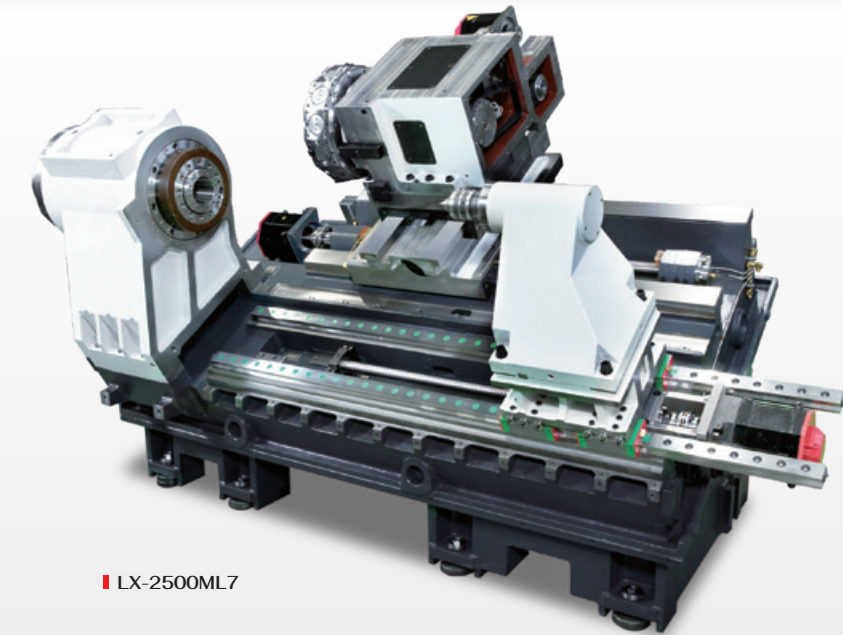

■ LX-2500ML7



■ LX-2500

Specifications

	LX-2500L7	LX-2500L13	LX-2500L20	LX-2500ML7	LX-2500ML13	LX-2500ML20	LX-2500YL7	LX-2500YL13	LX-2500YL20
Max. Swing	2461	2461	2461	2461	2461	2461	3071	3071	3071
Max. Turning Diameter	17.72 (T12) [18.5 (T10)]	17.72 (T12) [18.5 (T10)]	17.72 (T12) [18.5 (T10)]	16.54	16.54	16.54	16.54	16.54	16.54
Max. Turning Length	28.82	53.82	83.35	27.48	52.48	82.01	27.48	52.48	82.01
Max. Bar Work Capacity	3.19 [2.95 (G)]	3.19 [2.95 (G)]	3.19 [2.95 (G)]	3.19 [2.95 (G)]	3.19 [2.95 (G)]	3.19 [2.95 (G)]	3.19 [2.95 (G)]	3.19 [2.95 (G)]	3.19 [2.95 (G)]
Spindle Speed	3500 (B)(G)(P) [3000] (P)	3500 (B)(G)(P) [3000] (P)	3500 (B)(G)(P) [3000] (P)	3500 (B)(G)(P) [3000] (P)	3500 (B)(G)(P) [3000] (P)	3500 (B)(G)(P) [3000] (P)	3500 (B)(G)(P) [3000] (P)	3500 (B)(G)(P) [3000] (P)	3500 (B)(G)(P) [3000] (P)
Chuck Size	10"	10"	10"	10"	10"	10"	10"	10"	10"
Number of Tools	T12 [T10]	T12 [T10]	T12 [T10]	T12	T12	T12	T12	T12	T12
Number of Spindles	1	1	1	1	1	1	1	1	1

	LX-3000L7	LX-3000L13	LX-3000L20	LX-3000ML7	LX-3000ML13	LX-3000ML20	LX-3000YL7	LX-3000YL13	LX-3000YL20
Max. Swing	2461	2461	2461	2461	2461	2461	3071	3071	3071
Max. Turning Diameter	17.72 (T12) [18.5 (T10)]	17.72 (T12) [18.5 (T10)]	17.72 (T12) [18.5 (T10)]	16.54	16.54	16.54	16.54	16.54	16.54
Max. Turning Length	28.15	53.15	82.68	26.81	51.81	81.34	26.81	51.81	81.34
Max. Bar Work Capacity	3.54	3.54	3.54	3.54	3.54	3.54	3.54	3.54	3.54
Spindle Speed	2800	2800	2800	2800	2800	2800	2800	2800	2800
Chuck Size	12"	12"	12"	12"	12"	12"	12"	12"	12"
Number of Tools	T12 [T10]	T12 [T10]	T12 [T10]	T12	T12	T12	T12	T12	T12
Number of Spindles	1	1	1	1	1	1	1	1	1

* P : P Motor / G : Gear Box / B : Built-in Motor

* P : P Motor / G : Gear Box / B : Built-in Motor

High Accuracy Y-axis Turning Center

EX series

- EX-2000T
- EX-2000MT
- EX-2000S
- EX-2000MS
- EX-2000YT
- EX-2000YS



EX-2000

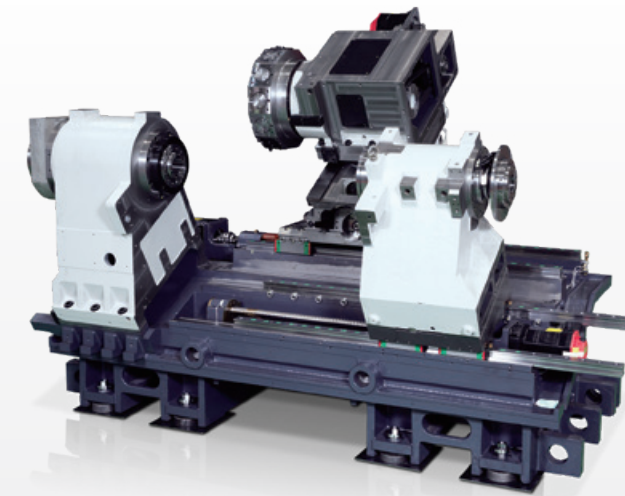

EX-2000



EX-2000

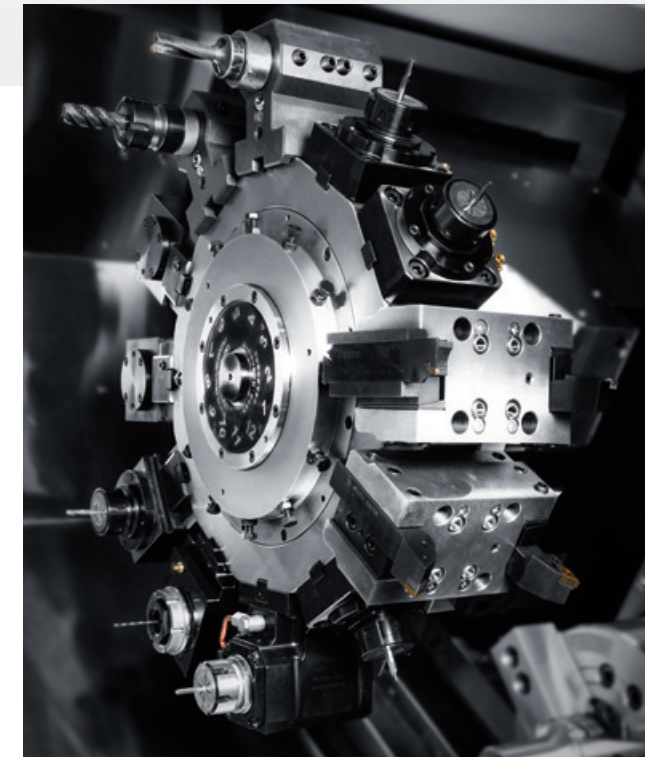

EX-2000

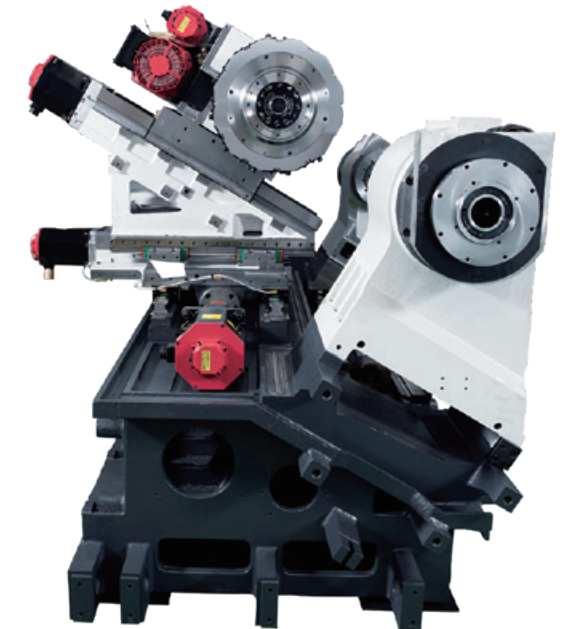

EX-2000

Specifications

	EX-2000T	EX-2000MT	EX-2000S	EX-2000MS	EX-2000YT	EX-2000YS
Max. Swing	31.50	31.50	31.50	31.50	31.50	31.50
Max. Turning Diameter	15.35	15.35	15.35	15.35	15.35	15.35
Max. Turning Length	20.10	20.10	20.10	20.10	20.10	20.10
Max. Bar Work Capacity	2.56	2.56	2.56 / 2.05	2.56 / 2.05	2.56	2.56 / 2.05
Spindle Speed	4500	4500	4500 / 5000	4500 / 5000	4500	4500 / 5000
Chuck Size	8"	—	8"	8"	—	8"
Number of Tools	T12	T12	T12	T12	T12	T12
Number of Spindles	1	1	2	2	1	2



EX-2000



EX-2000

High Productivity Turning Center with Opposed Turrets

MX series

- MX-800
- MX-800M2
- MX-800Y
- MX-800Y2



■ MX-800

Specifications

	MX-800	MX-800M2	MX-800Y	MX-800Y2
Max. Swing	12.20	12.20	12.20	12.20
Max. Turning Diameter	12.20	12.20	12.20	12.20
Max. Turning Length	9.84	9.84	9.84	9.84
Max. Bar Work Capacity	2.05 (2.56) / 2.05 (2.56)	2.05 (2.56) / 2.05 (2.56)	2.05 (2.56) / 2.05 (2.56)	2.05 (2.56) / 2.05 (2.56)
Spindle Speed	4000 (3500)	4000 (3500)	4000 (3500)	4000 (3500)
Chuck Size	8"	8"	8"	8"
Number of Tools	T12 + T12	T15 + T15	T15 + T15	T15 + T15
Number of Spindles	2	2	2	2



■ MX-800

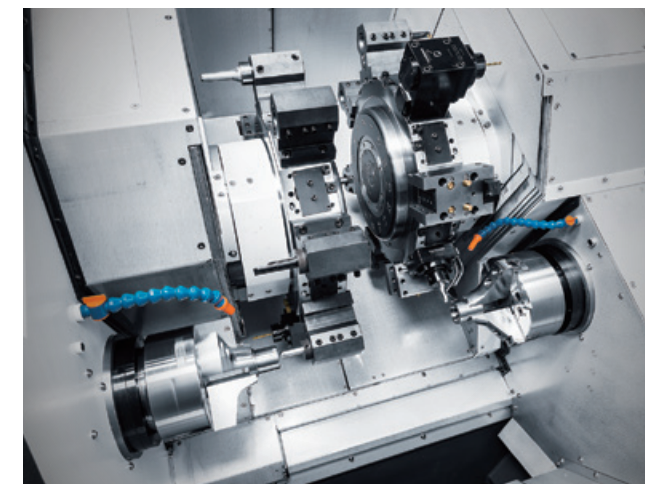

■ MX-800

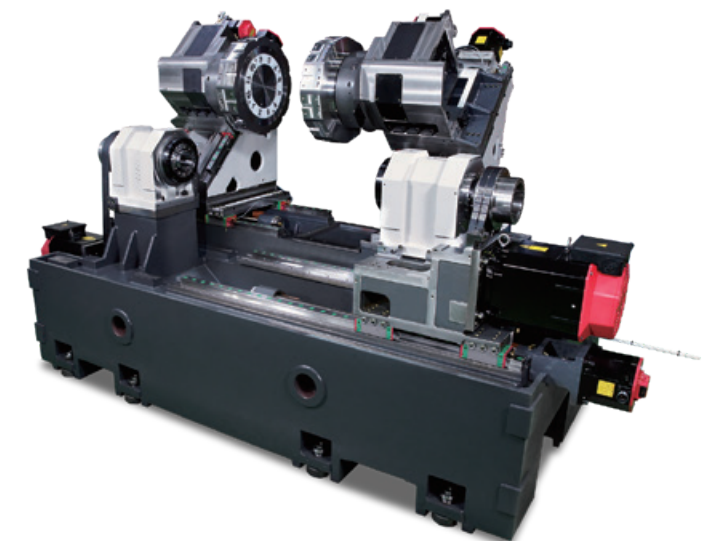

■ MX-800

High Productivity Turning Center with Upper / lower Turrets

FX series

- FX-600
- FX-800
- FX-1500



FX-800

Specifications

	FX-600	FX-800	FX-1500
Max. Swing	8.66	12.20	9.06
Max. Turning Diameter	11.81	12.20	9.06
Max. Turning Length	20.08	25.87	20.65
Max. Bar Work Capacity	1.65 / 1.65	2.56 / 2.05	1.65 (2.05/2.56) / 1.65 (2.05)
Spindle Speed	6000	4500 / 5000	6000 (5000/4500) / 6000 (5000)
Chuck Size	6"	8"	6" (8") / 6" (8")
Number of Tools	T12 + T12	T16 + T16	T12 + T12
Number of Spindles	2	2	2

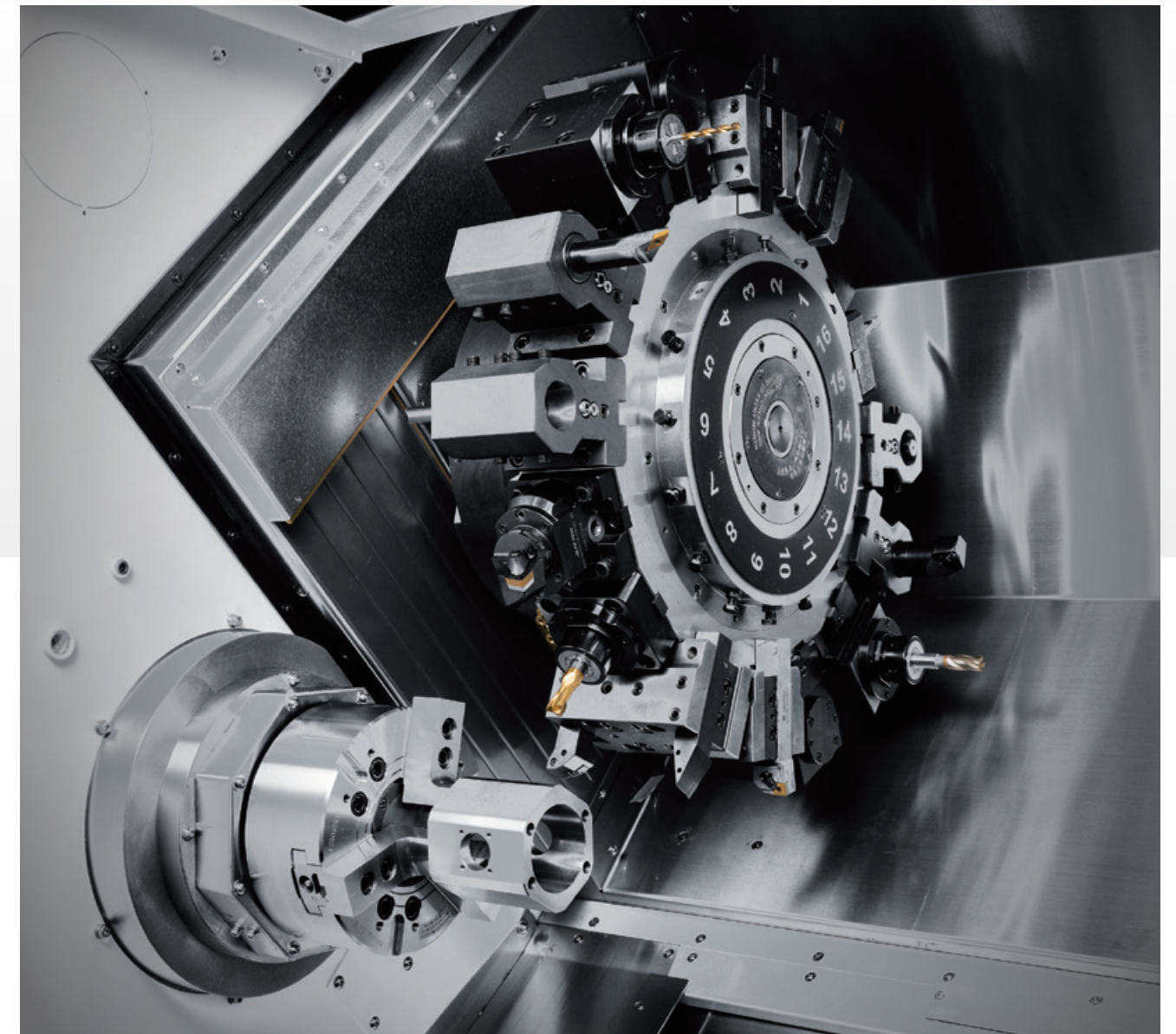

FX-800

Heavy Duty Vertical Turning Center

VTL series

- VTL-350R
- VTL-450R, VTL-450L,
- VTL-450MR, VTL-450ML
- VTL-750A
- VTL-760R, VTL-760L,
- VTL-760MR, VTL-760ML
- VTL-950R, VTL-950MR
- VTL-1100R, VTL-1100MR



■ VTL-450MR + VTL-450ML



■ VTL-1100M



■ VTL-1100M

Specifications

	VTL-350	VTL-450	VTL-450M	VTL-750A	VTL-760	VTL-760M	VTL-950	VTL-950M	VTL-1100	VTL-1100M
Max. Swing	25.59	23.62	23.62	41.34	33.46	33.46	38.98	38.98	52.36	52.36
Max. Turning Diameter	18.50	18.11	18.11	30.71	31.50	31.50	37.40	37.40	47.24	47.24
Max. Turning Length	16.34	16.34	14.96	30.12	27.56	26.77	33.86	33.86	38.78	38.78
Spindle Speed	2500	2500	2500	1500	2000	2000	850	850	850	850
Chuck Size	12"	12"	12"	24"	15"	15"	32"	32"	32"	32"
Number of Tools	T10	T12	T12	T6	T12	T12	T12	T12	T12	T12
Number of Spindles	1	1	1	1	1	1	1	1	1	1

Inverted Vertical Turning Center

YC series

- YC-108, YC-308
- YC-110, YC-310
- YC-120



YC-110

Specifications

	YC-108	YC-308	YC-110	YC-310	YC-120
Max. Swing	16.54	16.54	16.54	16.54	21.65
Max. Turning Length	14.09	14.09	14.09	14.09	14.17
Spindle Speed	4000	4000	3500	3500	2800
Chuck Size	8"	8"	10"	10"	12"
Number of Tools	T12	T12	T12	T12	T12
Number of Spindles	1	1	1	1	1

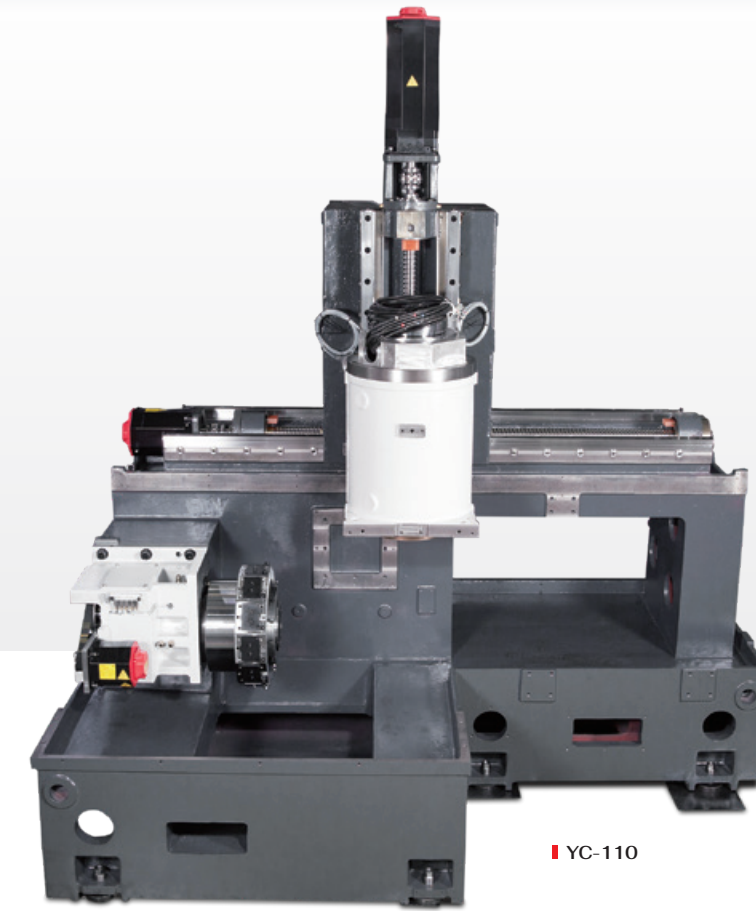

YC-110

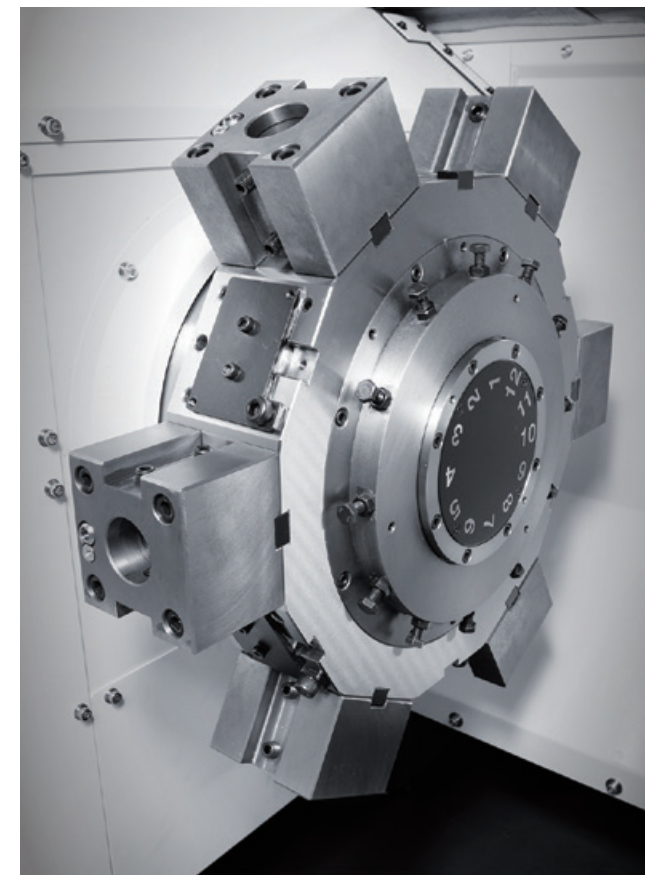

YC-110



YC-110