

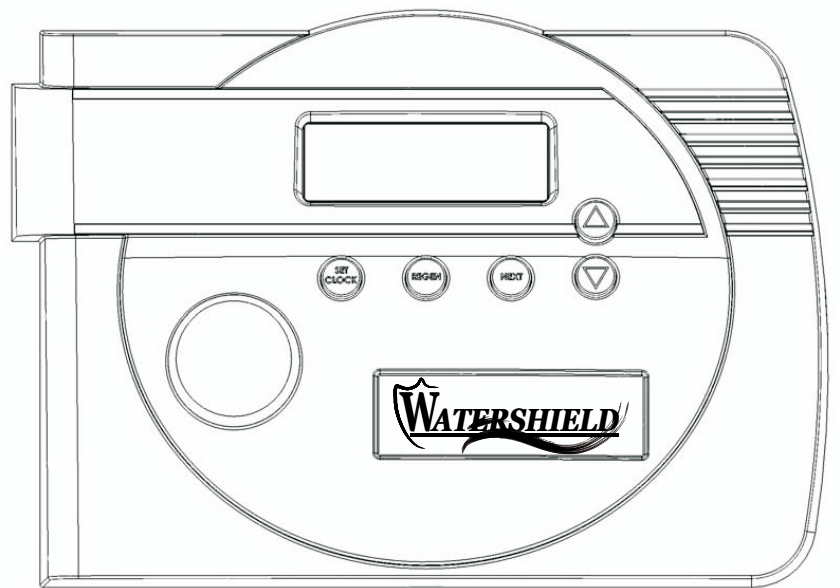

WATERSHIELD PLUS VALVES



Watershield Systems Product Warranty

Watershield, a division of Water Treatment Warehouse Inc., guarantees to the original owner, with proof of purchase, at the original location, that:

1. for 10 years on a fiberglass tank, and a lifetime on Watershield Premier tanks, the original owner at the original location, the mineral tank will not rust, corrode, leak, burst, or in any other manner fail to perform its proper function.
2. for a period of 10 years after installation, the salt tank will not rust, corrode, leak, burst, or in any other manner fail to perform its proper function.
3. for a period of 5 years after installation, the valve body will be free from defects in material and workmanship.
4. for a period of 5 years after installation, the electronic timer control panel and for a period of 1 year all other parts will be free from defects in material and workmanship.

If during such respective period a part proves, after inspection by Watershield, to be so defective, Watershield will, at its sole option, either replace or repair the defective part without charge except normal shipping and installation charges. During the first 90 days after installation, parts and replacement service necessary to maintain the mineral tank, salt tank, valve body and electronic timer control panel in factory operating condition in accordance with specifications published in the Owners's Guide, shall be furnished at absolutely no cost.

General Provisions

The above warranties are effective provided that the water conditioner is operated at water pressures not exceeding 125 p.s.i. and at temperatures not exceeding 120 degrees F; provided further that the water conditioner is not subject to abuse, misuse, alteration, neglect, freezing, accident or negligence; and provided further that the water conditioner is not damaged as the result of any unusual force of nature such as, but not limited to, flood, hurricane, tornado, or earthquake. The electronic timer control must have weather cover installed when water conditioner is installed outside.

Watershield systems is excused if failure to perform its warranty obligations is the result of strikes, government regulation, material shortages, or other circumstances beyond its control.

To obtain warranty service, notice must be given within 30 days of the discovery of the defect to your local Watershield dealer.

There are no warranties on the water condition beyond those described above. All implied warranties, including any implied warranty of merchantability or of fitness for a particular purpose, are disclaimed to the extent they might extend beyond the above periods. The sole obligation Watershield, under these warranties, is the replace or repair the component or part which proves to be defective within the specified time period, and Watershield is not liable for consequential or incidental damages. No Watershield dealer, agent, representative, or other person is authorized to extend or expand the warranties expressly described above.

Some states do not allow limitations on how long an implied warranty lasts or exclusions or limitations of incidental or consequential damages, so the limitations and exclusions in this warranty may not apply to you. This warranty gives you specific legal rights, and you may also have other rights which vary from state to state. This warranty applies to consumer-owned installations only.

TABLE OF CONTENTS

PAGE	1	GENERAL WARNING
PAGE	2	SPECIFICATIONS
PAGE	3-9	CYCLES AND SIZING
PAGE	9-10	BYPASS OPERATION
PAGE	11-13	GENERAL INSTRUCTIONS/SETUP
PAGE	14-16	SOFTENER SETUP
PAGE	17-19	FILTER SETUP
PAGE	20-25	DISPLAY SETTINGS
PAGE	26-27	INSTALLATION NOTES
PAGE	28-41	PART DRAWINGS
PAGE	42-46	SERVICE
PAGE	47-48	TROUBLESHOOTING
PAGE	49	DIAGRAM

TABLE OF CONTENTS

General Warnings (*Must appear in OEM's manual*)

The following general warnings and the specifications in Table 1 must appear in the OEM's System Manual.

The control valve, fittings and/or bypass are designed to accommodate minor plumbing misalignments but are not designed to support the weight of a system or the plumbing.

Do not use Vaseline, oils, other hydrocarbon lubricants or spray silicone anywhere. A silicone lubricant may be used on black o-rings but is not necessary. **Avoid any type of lubricants, including silicone, on the clear lip seals.**

The nuts and caps are designed to be unscrewed or tightened by hand or with the special plastic wrench. If necessary a pliers can be used to unscrew the nut or cap. Do not use a pipe wrench to tighten or loosen nuts or caps. Do not place a screwdriver in the slots on caps and/or tap with a hammer.

Do not use pipe dope or other sealants on threads. Use Teflon tape on the threaded inlet, outlet and drain fittings. Teflon tape is not necessary on the nut connection or caps because of o-ring seals.

After completing any valve maintenance involving the drive assembly or the drive cap assembly and pistons, press and hold NEXT and REGEN buttons for 3 seconds or unplug power source jack from the printed circuit board (black wire) and plug back in. This resets the electronics and establishes the service piston position. The display should flash all wording, then flash the software version and then reset the valve to the service position.

All plumbing should be done in accordance with local plumbing codes. The pipe size for the drain line should be a minimum of ½". Backwash flow rates in excess of 7 gpm or length in excess of 20' require ¾" drain line.

Solder joints near the drain must be done prior to connecting the drain line flow control fitting. Leave at least 6" between the drain line control fitting and solder joints when soldering pipes that are connected on the drain line control fitting. Failure to do this could cause interior damage to the drain line flow control fitting.

When assembling the installation fitting package (inlet and outlet), connect the fitting to the plumbing system first and then attach the nut, split ring and o-ring. Heat from soldering or solvent cements may damage the nut, split ring or o-ring. Solder joints should be cool and solvent cements should be set before installing the nut, split ring and o-ring. Avoid getting primer and solvent cement on any part of the o-rings, split rings, bypass valve or control valve.

Plug into an electrical outlet. Note: All electrical connections must be connected according to local codes. (Be certain the outlet is uninterrupted.)

Install grounding strap on metal pipes.

Table 1
Specifications which must be included in OEM's Manual

Minimum/Maximum Operating Pressures	20 psi (138 kPa) -125 psi (862 kPa)	
Minimum/Maximum Operating Temperatures	40°F (4°C) - 110°F (43°C)	
AC Adapter:	<u>U.S.</u>	<u>International</u>
Supply Voltage	120 V AC	230V AC
Supply Frequency	60 Hz	50 Hz
Output Voltage	12 V AC	12 V AC
Output Current	500 mA	500 mA
No user serviceable parts are on the PC board, the motor, or the AC adapter. The means of disconnection from the main power supply is by unplugging the AC adapter from the wall.		

Table 2 contains a summary of specifications for the control valve and bypass valve.

Table 2
Quick Reference Specifications

Service flow rate 1" (includes bypass and meter)	27 gpm (102.2 lpm) @15 psig (103 kPa) drop	
Backwash flow rate 1" (includes bypass)	27 gpm (102.2 lpm) @25 psig (172 kPa) drop	
Service flow rate 1.25" (includes meter)	34 gpm (128.7 lpm) @15 psig (103 kPa) drop	
Service flow rate 1.25" (includes bypass and meter)	32 gpm (121.1 lpm) @15 psig (103 kPa) drop	
Backwash flow rate 1.25"	32 gpm (121.1 lpm) @25 psig (172 kPa) drop	
Backwash flow rate 1.25" (includes bypass)	30 gpm (113.5 lpm) @25 psig (172 kPa) drop	
Minimum/Maximum Operating Pressures	20 psi (138 kPa) -125 psi (862 kPa)	
Minimum/Maximum Operating Temperatures	40°F (4°C) - 110°F (43°C)	
AC Adapter:	<u>U.S.</u>	<u>International</u>
Supply Voltage	120 V AC	230V AC
Supply Frequency	60 Hz	50 Hz
Output Voltage	12 V AC	12 V AC
Output Current	500 mA	500 mA
Regenerant Refill Rate	0.5 gpm (1.9 lpm)	
Injectors	See Injector Graphs	
Drain Line Flow Controls	See Table 7	
Inlet / Outlet Fitting Options	(a) 1" NPT elbow which has a unique drill out feature to allow a ¼" NPT connection to the inlet and/or outlet (b) ¾" & 1" PVC solvent weld fitting (c) 1" straight brass sweat fitting (d) ¾" straight brass sweat fitting (e) 1" plastic male NPT fitting (f) 1¼" plastic male NPT fitting (g) 1" plastic male BSPT fitting (h) 1¼" plastic male BSPT fitting (i) 1¼" & 1½" brass sweat fitting (j) 1¼" & 1½" PVC solvent fitting	
Distributor Tube Opening WS1ER Valve	1.05" outside diameter (¾" NPS)	
Distributor Tube Opening WS1.25ER Valve	1.32" outside diameter (1" NPS)	
	32 mm outside diameter	
Tank Thread	2½" - 8 NPSM	
Control Valve Weight	4.5 lbs.	2.0 kg
PC Board Memory	Nonvolatile EEPROM (electrically erasable programmable read only memory)	
Compatible with regenerants/chemicals	Sodium chloride, potassium chloride, potassium permanganate, sodium bisulfite, chlorine and chloramines	

Control Valve Function and Cycles of Operation

This glass filled Noryl¹ (or equivalent) fully automatic control valve is designed as the primary control center to direct and regulate all cycles of a water softener or filter. When the WS1ER control valve is manufactured as a softener, the control valve can be ordered to perform downflow or upflow regeneration. The WS1.25ER control valve is only available in downflow regeneration. When the WS1ER or WS1.25ER control valve is set up as a filter, the control valve can be set to perform downflow regeneration or simply backwash. The control valve can be set to regenerate on demand (consumption of a predetermined amount of water) and/or as a time clock (passage of a particular number of days). The control valve can be set so that a softener can meet the Water Quality Association (WQA) Standard S100 or NSF/ANSI Standard 44 efficiency rating.

It is not recommended to change control valves from downflow to upflow brining or vice versa in the field. The valve bodies for downflow and upflow are unique to the regeneration type and should not be interchanged. A mismatch of valve body and regeneration piston will result in hard water bypass during service.

The control valve is compatible with a variety of regenerants and resin cleaners. The control valve is capable of routing the flow of water in the necessary paths to regenerate or backwash water treatment systems. The injector regulates the flow of brine or other regenerants. The control valve regulates the flow rates for backwashing, rinsing, and the replenishing of treated water into a regenerant tank, when applicable.

The control valve uses no traditional fasteners (e.g. screws); instead clips, threaded caps and nuts and snap type latches are used. Caps and nuts only need to be firmly hand tightened because radial seals are used. Tools required to service the valve include one small blade screw driver, one large blade screw driver, pliers and a pair of hands. A plastic wrench is available which eliminates the need for screwdrivers and pliers. Disassembly for servicing takes much less time than comparable products currently on the market. Control valve installation is made easy because the distributor tube can be cut ½" above to ½" below the top of tank thread. The distributor tube is held in place by an o-ring seal and the control valve also has a bayonet lock feature for upper distributor baskets.

The AC adapter power pack comes with a 15 foot power cord and is designed for use with the control valve. The AC adapter power pack is for dry location use only. The control valve remembers all settings until the battery power is depleted if the power goes out. After the battery power is depleted, the only item that needs to be reset is the time of day; other values are permanently stored in the nonvolatile memory. The control valve battery is not rechargeable but is replaceable.

The control valve's unique design and electronics allow the OEM the flexibility shown in Tables 3 and 4.

**Table 3
Regeneration Cycles Softening**

WS1ER & WS1.25ER Downflow Regenerant Refill After Rinse	WS1ER & WS1.25ER Downflow Regenerant Prefill	WS1ER only Upflow Regenerant Refill After Rinse	WS1ER only Upflow Regenerant Prefill
1 st Cycle: Backwash	1 st Cycle: Fill	1 st Cycle: UP Brine	1 st Cycle: Fill
2 nd Cycle: dn Brine	2 nd Cycle: Softening	2 nd Cycle: Backwash	2 nd Cycle: Softening
3 rd Cycle: Backwash	3 rd Cycle: Backwash	3 rd Cycle: Rinse	3 rd Cycle: UP Brine
4 th Cycle: Rinse	4 th Cycle: dn Brine	4 th Cycle: Fill	4 th Cycle: Backwash
5 th Cycle: Fill	5 th Cycle: Backwash	5 th Cycle: End	5 th Cycle: Rinse
6 th Cycle: End	6 th Cycle: Rinse		6 th Cycle: End
	7 th Cycle: End		

¹ Noryl is a trademark of General Electric.

**Table 4
Regeneration Cycles Filtering**

WS1ER & WS1.25ER	
1 st Cycle:	Backwash
2 nd Cycle:	dn Brine
3 rd Cycle:	Backwash
4 th Cycle:	dn Brine
5 th Cycle:	Rinse

The control valve with a water meter can be set for Demand Initiated Regeneration (DIR) only, Time Clock operation only or DIR and Time Clock which ever comes first, depending upon what settings are selected for Day Override and Gallon Capacity.² See Table 5.

If a control valve does not contain a meter, the valve can only act as a time clock, and day override should be set to any number and gallon capacity should be set to off.

**Table 5
DIR/Time Clock Options**

DIR	Time Clock	Reserve Capacity	Softener	Filter		Settings ³	
				Regenerant	Backwash Only	Day Override	Gallon Capacity
Yes		Automatically calculated	Yes			Off	Auto
Yes		If desired enter a value less than estimated capacity	Yes	Yes	Yes	Off	Any Number
Yes	Yes	Automatically calculated	Yes			Any Number	Auto
Yes	Yes	If desired enter a value less than estimated capacity	Yes	Yes	Yes	Any Number	Any number
	Yes	None	Yes	Yes	Yes	Any Number	Off

For DIR Softeners, there are two options for setting the Gallons Capacity. The Gallons Capacity is automatically calculated if set to AUTO. Reserve Capacity is automatically estimated based on water usage if AUTO is used. The other option is to set the Gallons Capacity to a specific number. If a specific number is set, reserve capacity is zero, unless the value is manually set (i.e. the manufacturer intentionally sets the gallon capacity number below the calculated capacity of the system).

If the system is set up as a prefill upflow softener the control valve can also be set to normal or proportional brining. If proportional brining is selected, the actual salt level fill will be calculated by dividing the actual volume treated by the calculated volumetric capacity, then multiplying the salt level fill selected by this percentage.

The control valve can also be set to regenerate immediately or at the next regeneration time by changing the Regeneration Time Option. There are three choices for settings:

1. "NORMAL" means regeneration will occur at the preset regeneration time.
2. "on 0" means regeneration will occur when the gallons capacity reaches zero.
3. "NORMAL" and "on 0" means the regeneration will occur at the preset regeneration time unless the gallons capacity reaches zero. If the gallons capacity reaches zero the regeneration will begin 10 minutes after no water usage.

The user can initiate manual regeneration. The user has the option to request the manual regeneration at the delayed regeneration time or to have the regeneration occur immediately:

1. Pressing and releasing the REGEN button. "Regen Today" will flash on the display and the regeneration will occur at the delayed regeneration time. The user can cancel the request by pressing and releasing the REGEN button. This method of manually initiating regeneration is not allowed when the system is set to "on 0", i.e. to immediately regenerate when the gallon capacity reaches zero.
2. Pressing and holding the REGEN button for approximately 3 seconds will immediately start the regeneration. The user cannot cancel this request, except by resetting the control by pressing NEXT and REGEN buttons simultaneously for 3 seconds.

The WS1ER & WS1.25ER control valves consist of the following components:

- | | |
|--|---|
| 1. Drive Assembly | 6. Drain Line Flow Control and Fitting Assembly |
| 2. Drive Cap Assembly, Main Piston and Regenerant Piston | 7. Water Meter or Meter Plug |
| 3. Spacer Stack Assembly | 8. Mixing Valve (optional) |
| 4. Injector Cap, Screen, Injector Plug and Injector | 9. Installation Fitting Assemblies |
| 5. Refill Flow Control Assembly or Refill Port Plug | 10. Bypass Valve (optional) |

Note: The WS1ER & WS1.25ER share many of the same components. Refer to Figure 6 for control valve identification.

² See Installer Display Settings, OEM Softener System Setup and OEM Filter System Setup for explanations of Day Override and Gallon Capacity.
³ Day Override and Gallon Capacity can not both be set to "oFF" at the same time.

Drive Assembly

The drive assembly consists of the following parts:

- Drive Bracket
- Printed Circuit (PC) Board
- Motor
- Drive Gears
- Drive Gear Cover

The drive bracket holds the PC board, the motor, the drive gears and the drive gear cover in place.

The PC board receives and retains information, displays the information, determines when to regenerate and initiates regeneration. The display shows different types of information in the initial system set up (for softeners or filters), installer display settings, diagnostics, valve history or user display settings.

The PC board powers the motor. The PC board's two-prong jack connects wires to the direct current (DC) motor. The motor is held in place on the drive bracket by a spring-loaded clip and a small bulge in the plastic, which fits in one of the slots on the motor housing. The motor turns drive gears that drive the piston to cycle positions for backwashing, regeneration, rinsing, refill or service. The motor is fully reversible (turns both ways) and changes direction of rotation to change the direction of piston motion. The motor is easily replaced if necessary.

There are three drive gears held in place by the drive gear cover. All three drive gears are the same size. A reflective coating is applied to the gears. As the center drive gear turns a light shines on the coating and a light sensing diode determines if a light pulse was returned. The PC board counts the pulses and determines when to stop driving the motor.

Drive Cap Assembly, Main Piston and Regenerant Piston

The drive gears turn the main gear of the drive cap assembly, which moves the piston. The screw-driven, horizontally moving piston stops at specific positions to direct the flow of water to backwash, regenerate, rinse or refill. The PC board determines the position of the piston by counting pulses produced when the piston is moved. An optical sensor looking at one of the reduction drive gears generates these pulses. Each cycle position is defined by a number of pulses. The counter is zeroed each time the valve goes to the service position. The PC board finds the service position by noting the increase in current delivered to the motor when the mechanical stop at the service position is reached. This method of controlling piston position allows for greater flexibility and requires no switches or cams (U.S. Patent 6444127).

One of three main pistons is always used:

1. A 1.25" diameter downflow piston is used when the WS1ER control valve is used as a downflow softener, regenerating filter or non-regenerating filter.
2. A 1.25" diameter upflow piston is used when the WS1ER control valve is used as an upflow softener.
3. A 1.5" diameter downflow piston is used when the WS1.25ER control valve is used as a downflow softener, regenerating filter or non-regenerating filter. An upflow piston is not available for the WS1.25ER control valve.

If the control valve is used as a softener or a regenerating filter, a regenerant piston must be attached to the main piston. If the control valve is to be used on a system that does not require a regenerant to be added, the regenerant piston must be removed.

Spacer Stack Assembly

The spacer stack assembly provides the necessary flow passage for water during the different cycles. The all-plastic spacer stack assembly (U.S. Patent 6402944) is a one-piece design which allows the stack to be removed using your fingers.

The exterior of the stack is sealed against the body bore with self lubricating EPDM o-rings, while the interior surface is sealed against the piston using slippery self cleaning directional (one-way) silicone lip seals. The lip seals are clear in color and have a special slippery coating so that the piston does not need to be lubricated.

Injector Cap, Screen, Injector Plug and Injector

The screen, injector and/or injector plug(s) are installed under the injector cap in an easy to access location on top of the valve. The injector cap contains four slots so no water accumulates in the cap. The injector cap is designed to be hand tightened.

Under the injector cap there is an easy to clean removable screen to prevent fouling of the injector. There are two holes under the injector cap labeled “DN” and “UP”. The holes will be filled with a plug or an injector.

The plug (Order # V3010-1Z) prevents water from traveling a certain pathway. The injector lets water pass through the pathway. The self-priming injector increases the velocity of the water, creating a zone of negative pressure that draws in the concentrated liquid regenerant, such as sodium chloride (brine), potassium permanganate, etc. The regenerant blends with the stream of water, which passes through the media to regenerate the bed.

The injector provides a consistent regenerant/water mixture ratio over the entire operating pressure range of the control valve. The injector provides good performance in a variety of applications, which may involve elevated drain lines and long regenerant draw lengths. Injectors are chosen by knowing the type, amount, and regenerant flow rate for a particular type of media. Guidelines can be found in the media manufacturer’s literature. The color coded injectors give different regenerant draw, slow rinse and total flow rates over the pressure range. See Table 6 for color codings, and injector graphs for total, slow rinse and draw flow rates.

**Table 6
Injector Order Information**

Injector Order Number	Injector Color	Typical Tank Diameter ⁴	
		Down WS1ER & WS1.25ER	Up WS1ER Only
V3010-1A	Black	6"	8"
V3010-1B	Brown	7"	9"
V3010-1C	Violet	8"	10"
V3010-1D	Red	9"	12"
V3010-1E	White	10"	13"
V3010-1F	Blue	12"	14"
V3010-1G	Yellow	13"	16"
V3010-1H	Green	14"	18"
V3010-1I	Orange	16"	22"
V3010-1J	Light Blue	18"	
V3010-1K	Light Green	22"	

The control valve has been manufactured to be one of the following:

- regeneration downflow WS1ER & WS1.25ER (for softeners or regenerating filters install injector in DN location, plug in UP location)
- regeneration upflow WS1ER only (upflow option is for softeners only, install injector in UP location, plug in other hole location)
- no regenerant WS1ER & WS1.25ER (both the DN and UP holes have injector plugs installed) and plug installed for the refill elbow

NOTE: It is not recommended to field convert valves from upflow to downflow and vice versa. Separate areas in the valve supply water to the injector for upflow and downflow valves.

Refill Flow Control Assembly or Refill Port Plug

The refill flow control assembly consists of a refill flow elbow, refill flow control retainer assembly, refill flow control, polytube insert and nut assembly. The refill flow control retainer fits in the refill elbow. The refill flow control retainer houses the refill flow control which controls the flow rate when the regenerant tank is being refilled. The refill flow control is a flexible washer-like part with a small orifice and a precision molded contour that delivers a steady 0.5 gpm regenerant tank refill rate at varying inlet pressures. Refill is accomplished with treated water.

⁴ Actual tank size used may vary depending on the design and application of the system. Tank diameter is an approximation for the following:

1. downflow softener using standard mesh synthetic cation exchange media regenerating with sodium chloride.
2. upflow softener using standard mesh synthetic cation exchange media regenerating with sodium chloride, an inlet water pressure of 3 to 50 psi and water temperature of 60°F water or warmer. Higher pressures or lower temperatures would need smaller injectors to avoid lifting the bed.

The refill flow control assembly is installed in an easy to access refill elbow located on top of the control valve. The refill flow control assembly is attached to the control valve with a locking clip. The locking clip allows the elbow to rotate 270 degrees so the outlet can be orientated towards the regenerant tank.

The control valve has a standard refill elbow to which a 3/8" flexible tube can be connected. An optional elbow can be ordered which accommodates a 1/2" flexible tube for a high regenerant draw rate situation (G injectors and larger). Both elbows use the same refill flow control and retainer.

If the control valve is to be used as a non-regenerant filter control valve, the refill elbow is removed and replaced with a refill port plug P/N V3195-01.

Drain Line Flow Control and Fitting Assembly

The drain line flow control assembly includes a drain line flow control and a fitting. The drain line flow control allows proper media bed expansion by regulating the flow rate to the drain. The drain line flow control is a flexible washer-like part with an orifice and a precision molded contour. The flow rates are within $\pm 10\%$ over the pressure range of 20 psi to 125 psi. See Table 7 for flow rate information.

Table 7
Drain Line Flow Control and Fitting Assembly Information

Drain Line Fitting	Drain Line Flow Control Order No.	Number on Drain Line Flow Control	Backwash Flow Rate (gpm)	Backwash Flow Rate (lpm)
3/4"	V3162-007	007	0.7	2.6
3/4"	V3162-010	010	1.0	3.8
3/4"	V3162-013	013	1.3	4.9
3/4"	V3162-017	017	1.7	6.4
3/4"	V3162-022	022	2.2	8.3
3/4"	V3162-027	027	2.7	10.2
3/4"	V3162-032	032	3.2	12.1
3/4"	V3162-042	042	4.2	15.9
3/4"	V3162-053	053	5.3	20.1
3/4"	V3162-065	065	6.5	24.6
3/4"	V3162-075	075	7.5	28.4
3/4"	V3162-090	090	9.0	34.1
3/4"	V3162-100	100	10.0	37.9
1"	V3190-090	090	9.0	34.1
1"	V3190-100	100	10.0	37.9
1"	V3190-110	110	11	41.6
1"	V3190-130	130	13	49.2
1"	V3190-150	150	15	56.8
1"	V3190-170	170	17	64.3
1"	V3190-200	200	20	75.7
1"	V3190-250	250	25	94.6

The drain line flow control and fitting are located on top of the control valve and replaceable without the use of special tools.

The drain line flow control can be installed in the standard 3/4" drain line elbow, which accommodates 5/8" polytube or 3/4" NPT drain line connections. The optional nut and polytube insert for the 3/4" drain line elbow is designed for use with flexible polytube only. The 3/4" drain line elbow can be rotated 180 degrees so the outlet can be orientated to the nearest drain. The same retainer is used for all drain line flow controls for the 3/4" fitting. Drain line flow controls designed for the 3/4" fitting are available for flow rates ranging from 0.7 to 10 gpm.

An optional 1" straight drain line fitting is available to accommodate drain line flow rates ranging from 9 to 25 gpm. This fitting is straight but still connects to the control valve using the same locking clip. The drain line flow control is located between two fitted parts (i.e. the fitting acts as the retainer). The nut is unscrewed to access the drain line flow control.

Water Meter or Meter Plug

The water meter is installed on the outlet side of the control valve. The water meter uses a turbine to measure gallons of treated water. The turbine rotates with the flow of water and reports its rate of rotation through Hall effect⁵ circuitry to the printed circuit (PC) board. This rotation permits the PC board to record the total volume of treated water and the flow rate. The small centrally located magnet is shielded from water, which substantially reduces iron-fouling problems with the turbine.

THIS WATER METER SHOULD NOT BE USED AS THE PRIMARY MONITORING DEVICE FOR CRITICAL HEALTH EFFECT APPLICATIONS.

The turbine is accurate to within $\pm 5\%$ over a wide operating flow rate range (0.25 gpm up to control valve maximums) and has a very low pressure drop. Water used for regeneration is not metered. If the control valve is set to refill the regenerant, water used between the refill cycle up to the start of the regeneration cycle is metered. If the control valve is in regeneration mode (e.g. a backwash cycle) and there is a water demand, that water usage is not metered.

When facing the front of the control valve, the water meter is positioned on the left-hand side of the control valve. Allow sufficient clearance to clean and repair the water meter without disconnecting the plumbing or disassembling any other parts of the control valve.

Control valves can be ordered with a meter plug (i.e. no electronics or turbine) rather than a water meter if desired. Control valves without meters should only be set up for time clock operation (i.e. no water meter, no demand-initiated regeneration). Control valves with water meters provide a wider variety of useful information (see OEM General Instructions for list of information).

A unique feature of this control valve is the ability to display actual water usage for the last 63 days. The values are initially stored as “----”. This means the value is unknown. As days pass values are stored as “0” for no flow or the actual number of gallons. The counting of the gallons starts at the regeneration time. If no regeneration time can be set (i.e. when the valve is set for immediate regeneration) the counting of gallons starts at 12 a.m. Day 1 is yesterday, day 2 the day before yesterday, etc. As new values are added the oldest history disappears.

Another unique feature is that the valve automatically calculates a reserve capacity when set up as a softener with “Gallons Capacity” set to “AUTO” and the “Regeneration Time Option” set to “Normal” or “Normal + on 0”. The actual reserve capacity is compared to the gallons capacity remaining immediately prior to the preset regeneration time. A regeneration will occur if the actual reserve capacity is less than the gallons capacity remaining. The actual reserve capacity is calculated by using the estimated reserve capacity and adjusting it up or down for actual usage.

The estimated reserve capacity for a given day of the week is the maximum value stored for the last three non-trivial water usages (i.e. more than 20 gallons/day) in seven day intervals.

Mixing Valve

The mixing valve is installed on the outlet side of the control valve. The mixing valve is used to blend raw water with treated water.

To adjust the blended water, close the mixing valve. Open a water faucet to the desired flow rate. Open the mixing valve until the desired hardness is reached. Close the faucet.

Installation Fitting Assemblies

The installation fittings are used to connect the optional bypass or the control valve to the plumbing system. The following fitting assemblies are available:

1. 1” NPT elbow assembly
2. ¾” & 1” PVC solvent weld elbow fitting assembly
3. 1” straight brass sweat fitting assembly⁶
4. ¾” straight brass sweat fitting assembly⁶
5. 1” plastic male NPT fitting assembly
6. 1¼” plastic male NPT fitting assembly
7. 1” plastic male BSPT fitting assembly
8. 1¼” plastic male BSPT fitting assembly
9. 1¼” & 1½” brass sweat fitting assembly⁶
10. 1¼” & 1½” PVC solvent fitting assembly

⁵ Some semiconductor materials exhibit a phenomenon in the presence of a magnetic field that is adaptable to sensing devices. When a current is passed through one pair of wires attached to a semiconductor, another pair of wires properly attached and oriented with respect to the semiconductor will develop a voltage proportional to the magnetic field present and the current in the other pair of wires. Holding the exciting current constant and moving a permanent magnet near the semiconductor produces a voltage output proportional to the movement of the magnet. Hall effect devices provide a high speed response, excellent temperature stability, and no physical contact.

⁶ Has not been tested for compliance with California Proposition 65, so this fitting should not be installed in California.

The installation fitting assemblies are sold in pairs and consist of two fittings, two nuts, two split rings and two o-rings. The installation fitting assemblies and the bypass valve are sold separately from the control valve.

Both elbow fittings have a unique drill out feature to allow a ¼” NPT connection to the inlet and/or outlet which can be used for a RO feed, test ports, pressure tap ports, etc.

Bypass Valve

The bypass valve is typically used to isolate the control valve from the plumbing system’s water pressure in order to perform control valve repairs or maintenance. The WS1 bypass valve is particularly unique in the water treatment industry due to its versatility and state of the art design features. The 1” full flow bypass valve incorporates four positions, including a diagnostic position that allows service personal to work on a pressurized system while still providing untreated bypass water to the facility or residence. Its completely non-metallic, all-plastic design allows for easy access and serviceability without the need for tools.

The bypass body and rotors are glass filled Noryl⁷ (or equivalent) and the nuts and caps are glass filled polypropylene. All seals are self-lubricating EPDM to help prevent valve seizing after long periods of non-use. Internal o-rings can easily be replaced if service is required.

The bypass consists of two interchangeable plug valves that are operated independently by red arrow-shaped handles. The handles identify the flow direction of the water. The plug valves enable the bypass valve to operate in four positions.

- 1. Normal Operation Position:** The inlet and outlet handles point in the direction of flow indicated by the engraved arrows on the control valve. Water flows through the control valve during normal operation and this position also allows the control valve to isolate the media bed during the regeneration cycle. (See Figure 1)
- 2. Bypass Position:** The inlet and outlet handles point to the center of the bypass, the control valve is isolated from the water pressure contained in the plumbing system. Untreated water is supplied to the plumbing system. (See Figure 2)
- 3. Diagnostic Position:** The inlet handle points in the direction of flow and the outlet handle points to the center of bypass valve, system water pressure is allowed to the control valve and the plumbing system while not allowing water to exit from the control valve to the plumbing. (See Figure 3)
- 4. Shut Off Position:** The inlet handle points to the center of the bypass valve and the outlet handle points in the direction of flow, the water is shut off to the plumbing system . If water is available on the outlet side of the softener it is an indication of water bypass around the system (i.e. a plumbing connection somewhere in the building bypasses the system). (See Figure 4)

⁷ Noryl is a trademark of General Electric.

BYPASS VALVE OPERATION

Figure 1

NORMAL OPERATION

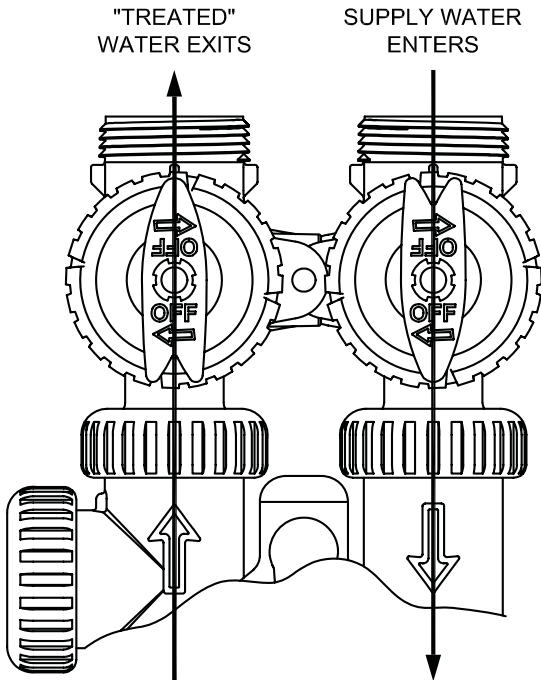

Figure 2

BYPASS OPERATION

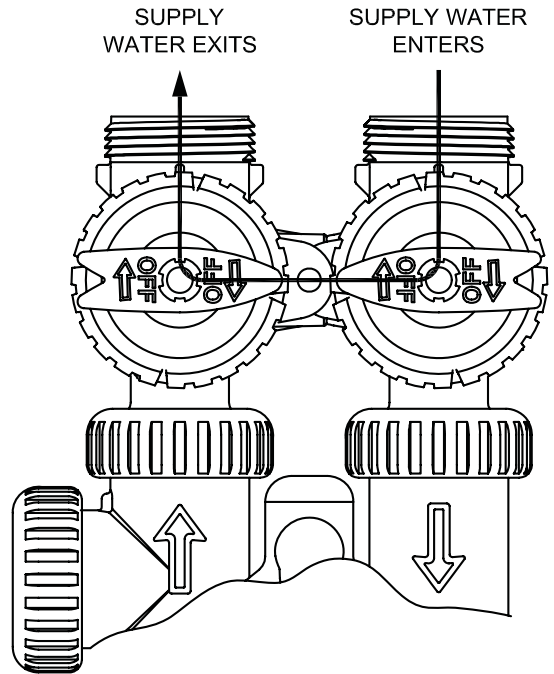

Figure 3

DIAGNOSTIC MODE

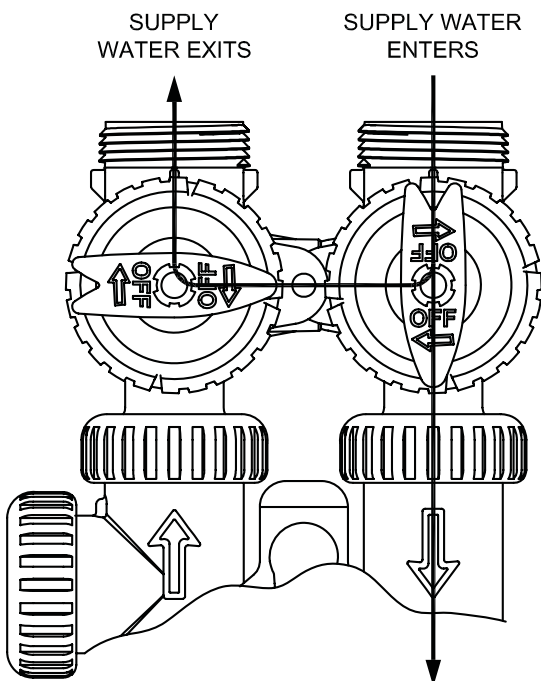
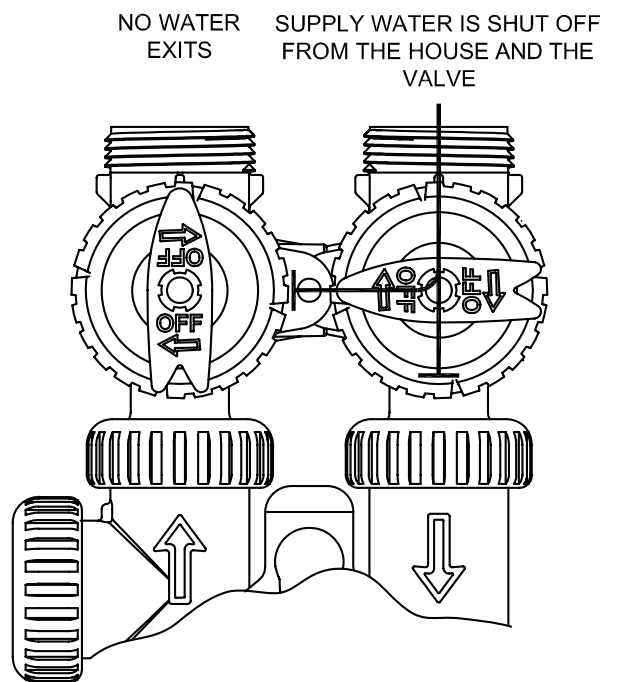

Figure 4

SHUT OFF MODE



OEM General Instructions

The control valve offers multiple procedures that allow the valve to be modified to suit the needs of the installation. These procedures are:

- OEM Setup
- OEM Softener System Setup
- OEM Filter System Setup
- Installer Display Settings
- User Display Settings
- Diagnostics
- Valve History

Once the OEM Setup has been set, the other procedures can be accessed in any order. Details on each of the procedures are provided on the following pages.

At the discretion of the manufacturer, the field technician can access all settings. To “lock out” access to diagnostic and valve history displays and modifications to settings except hardness, day override, time of regeneration and time of day by anyone but the manufacturer, press ▼, NEXT, ▲, and SET CLOCK in sequence after settings are made. To “unlock”, so other displays can be viewed and changes can be made, press ▼, NEXT, ▲, and SET CLOCK in sequence.

When in operation normal user displays such as time of day, gallons remaining before regeneration, days remaining before regeneration or lbs. salt remaining before regeneration are shown. When stepping through a procedure, if no buttons are pressed within five minutes, the display returns to a normal user display. Any changes made prior to the five minute time out are incorporated.

To quickly exit OEM Softener Setup, OEM Filter Setup, Installer Display Settings, Diagnostics or Valve History press SET CLOCK. Any changes made prior to the exit are incorporated.

When desired, all information in Diagnostics may be reset to zero when the valve is installed in a new location. To reset to zero, press NEXT and ▼ buttons simultaneously to go to the Service/OEM 1 screen, and release. Press ▲ and ▼ simultaneously to reset diagnostic values to zero. Screen will return to User Display.

Sometimes it is desirable to have the valve initiate and complete two regenerations within 24 hours and then return to the preset regeneration procedure. It is possible to do a double regeneration if the control valve is set to “NORMAL” or “NORMAL + on 0” in OEM Softener System Setup or OEM Filter System Setup. To do a double regeneration:

1. Press the “REGEN” button once. REGEN TODAY will flash on the display.
2. Press and hold the “REGEN” button for three seconds until the valve regeneration initiates.

Once the valve has completed the immediate regeneration, the valve will regenerate one more time at the preset regeneration time.

Proportional Brining

If the system is set up as a prefill upflow softener, the control valve can also be set to normal or proportional brining.



This step will appear after Step 7S and before Step 8S if the system is set up as a prefill upflow softener. The following options can be selected:

- NORMAL FILL - System always prefills with the salt level selected.
- ProP FILL - If proportional brining is selected the actual salt level fill will be calculated by dividing the actual volume treated by the calculated volumetric capacity, then multiply the salt level fill selected by this percentage.

Press NEXT to go to the next step. Press REGEN to return to the previous step.



OEM Setup

OEM Setup instructions allows the OEM to set meter size, dPswitch or alternating valve, pre or post fill and dn or up brine where applicable. Fill and brine values are ignored when the system is set up as a filter. The OEM Softener System Setup or the OEM Filter System Setup allow the OEM to set how long cycles will last.

Verify the correct valve body, main piston, regenerant piston, and stack are being used, and that the injector or injector plug(s) are in the correct locations. See Compliance Table in Service Instructions under Injector Cap, Screen, Injector Plug and Injector section and Figure 6.

The following is an example of how to set a valve so that when regeneration is initiated BACKWASH occurs first, dn BRINE occurs second, RINSE occurs third, and FILL occurs fourth.

STEP 1OS **Step 1OS** – Press NEXT and ▼ simultaneously for 3 seconds and release. Then press NEXT and ▼ simultaneously for 3 seconds and release. If screen in Step 2CS does not appear in 5 seconds the lock on the valve is activated. To unlock press ▼, NEXT, ▲, and SET CLOCK in sequence, then press NEXT and ▼ simultaneously for 3 seconds and release. Then press NEXT and ▼ simultaneously for 3 seconds and release.

STEP 2OS **Step 2OS** – Use the ▲ or ▼ to select 1.0 for WS1ER or 1.25 for WS1.25ER valve. Press NEXT to go to Step 3OS. Press REGEN to exit OEM Cycle Sequence.

STEP 3OS **Step 3OS** – Selection only matters if a connection is made to the two pin connector labeled DP SWITCH located on the printed circuit board. Following is an explanation of the options:

- dPon0 - If the dP switch is closed for an accumulative time of 2 minutes a regeneration will occur immediately.
- dPdEL - If the dP switch is closed for an accumulative time of 2 minutes a regeneration will occur at the scheduled regeneration time.
- HoLd - If the dP switch is closed a regeneration will be prevented from occurring.

Press NEXT to go to Step 4OS. Press REGEN to return to previous step.

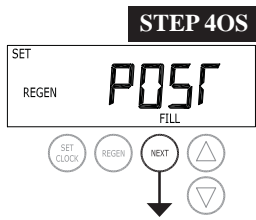

STEP 4OS – Set Refill option using ▼ or ▲ buttons:

- “PoST” to refill the brine tank after the final rinse; or
- “PrE” to refill the brine tank two hours before the regeneration time set.

Press NEXT to go to Step 4OS. Press REGEN to return to previous step.

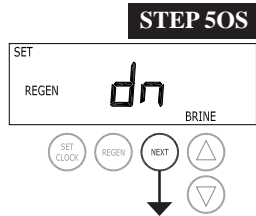

STEP 5OS – Set regenerant downflow or upflow using ▼ or ▲ buttons:

- “dn” if the regenerant is to flow downward through the media; or
- “UP” if the regenerant is to flow upward through the media. Step 1OS must be set to 1 for a 1” valve.

Prior to selecting a regenerant flow direction, verify the correct valve body, main piston, regenerant piston, and stack are being used, and that the injector or injector plug(s) are in the correct locations. See Compliance Table in Service Instructions under Injector Cap, Screen, Injector Plug and Injector section and Figure 6. This screen will not display if the unit is set up as a 1.25” or filter valve.

RETURN TO NORMAL MODE

Press NEXT to exit OEM Setup. Press REGEN to return to previous step.

OEM Softener System Setup

In OEM Softener System Setup the OEM chooses the value for the specified cycles (the order of which is specified by the selections for Step 4OS and Step 5OS in OEM Setup) and specifies other operating parameters for the system. If a cycle is present the value can be set to off. Fill is in pounds of salt and all other cycles are in minutes.

Step 4OS	Step 5OS	Cycle Order
Post	dn	Backwash, Brine, Backwash, Rinse, Fill
Pre	dn	Fill, Service, Backwash, Brine, Backwash, Rinse
Post	UP	Brine, Backwash, Rinse, Fill
Pre	UP	Fill, Service, Brine, Backwash, Rinse

STEP 1S

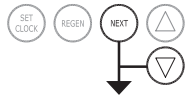

Step 1S – Press NEXT and ▼ simultaneously for 3 seconds and release. If screen in Step 2S does not appear in 5 seconds the lock on the valve is activated. To unlock press ▼, NEXT, ▲, and SET CLOCK in sequence, then press NEXT and ▼ simultaneously for 3 seconds and release.

STEP 2S



Step 2S – Choose SOFTENING using the ▼ or ▲ button. Press NEXT to go to Step 3S. Press REGEN to exit OEM Softener System Setup.

STEP 3S



Step 3S – Select the time for the first cycle (which in this example is BACKWASH) using the ▼ or ▲ button. Press NEXT to go to Step 4S. Press REGEN to return to previous step.

STEP 4S



Step 4S – Select the time for the second cycle (which in this example is dn BRINE) using the ▼ or ▲ button. Verify the correct valve body, main piston, regenerant piston, and stack are being used, and that the injector or injector plug(s) are in the correct locations. See Compliance Table in Service Instructions under Injector Cap, Screen, Injector Plug and Injector section and Figure 6. Press NEXT to go to Step 5S. Press REGEN to return to previous step.

NOTE: The display will flash between cycle number and time, and brine direction (dn or UP).

STEP 5S



Step 5S – Select the time for the third cycle (which in this example is RINSE) using the ▼ or ▲ button. Press NEXT to go to Step 6S. Press REGEN to return to previous step.

STEP 6S



Step 6S – Select the LBS for the fourth cycle (which in this example is FILL) using the ▼ or ▲ button. Press NEXT to go to Step 7S. Press REGEN to return to previous step.

STEP 7S

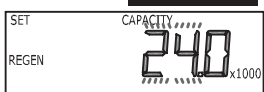

Step 7S –Set Grains Capacity using the ▼ or ▲ button. The ion exchange capacity is in grains of hardness as calcium carbonate for the system based on the pounds of salt that will be used. Calculate the pounds of salt using the fill time previously selected. The allowable grains capacity range varies from 5000 to 500,000 grains. The increment increase is 500 for the range from 5000 to 50,000; 2000 for the range of 50,000 to 200,000; and 5000 for the range of 200,000 to 500,000. Grains capacity is affected by the fill time. The grains capacity for the selected fill time should be confirmed by OEM testing. The capacity and hardness levels entered are used to automatically calculate reserve capacity when gallon capacity is set to AUTO. Press NEXT to go to Step 8S. Press REGEN to return to previous step.

STEP 8S

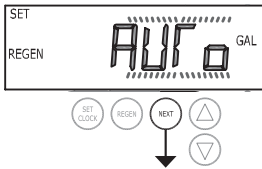

Step 8S – Set Volume Capacity using the ▼ or ▲ button. If value is set to:

- “AUTO” capacity will be automatically calculated and reserve capacity will be automatically estimated;
- “oFF” regeneration will be based solely on the day override set (see Installer Display Settings Step 3I); or
- as a number (allowable range 20 to 250,000) regeneration initiation will be based off the value specified. Increment increase is 20 for the range 20 to 2000, 100 for the range of 2000 to 10,000, 500 for the range 10,000 to 50,000 and 2000 for the range of 50,000 to 250,000.

If “oFF” or a number is used, hardness display will not be allowed to be set in Installer Display Settings Step 2I. See Table 8 for more detail. Press NEXT to go to Step 9S. Press REGEN to return to previous step.

STEP 9S

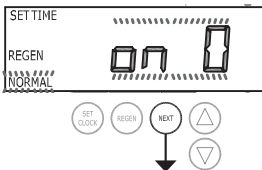

Step 9S – Set Regeneration Time Options using the ▼ or ▲ button. If value is set to:

- “NORMAL” means regeneration will occur at the preset time;
- “on 0” means regeneration will occur immediately when the gallons capacity reaches 0 (zero); or
- “NORMAL + on 0” means regeneration will occur at one of the following:
 - the preset time when the gallons capacity falls below the reserve or the specified number of days between regenerations is reached, whichever comes first; or
 - after 10 minutes of no water usage when the gallons capacity reaches 0 (zero). See Table 8 for more detail.

Press NEXT to go to Step 10S. Press REGEN to return to previous step.

STEP 10S

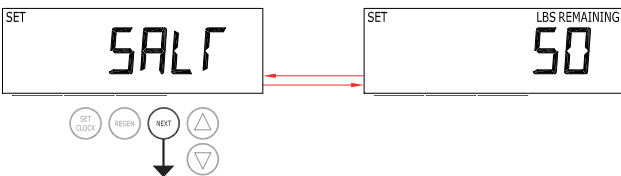

Step 10S – Set Low Salt Warning using the ▼ or ▲ button. If value is set to:

- “oFF” no low salt level warning will appear for the user; or
- a specific value “FILL SALT” will flash on the display when the calculated remaining pounds of salt falls below that level. Allowable values range form 10 to 400 pounds in 10 pound increments.

Press NEXT to go to Step 11S. Press REGEN to return to previous step.

STEP 11S

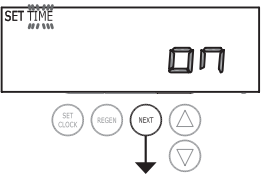

Step 11S: Set Relay operation using the ▲ or ▼ button. The choices are:

- Set Time on: Relay activates after a set time at the beginning of a regeneration and then deactivates after a set period of time. The start of regeneration is defined as the first backwash cycle, Dn brine cycle or UP brine cycle which ever comes first.
- Set Gal on: Relay activates after a set number of gallons has been treated and then deactivates after a set period of time or after the meter stops registering flow, whichever comes first.
- Set Off: If set to Off, Steps 12S and 13S will not be shown.

Press NEXT to go to Step 12S. Press REGEN to return to previous step.

STEP 12S

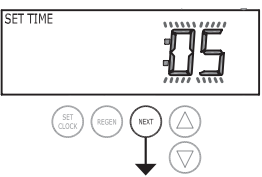

Step 12S: Set Relay Actuation Time or Gallons using the ▲ or ▼ buttons. The choices are:

- Relay Actuation Time: After the start of a regeneration the amount of time that should pass prior to activating the relay. The start of regeneration is defined as the first backwash cycle, Dn brine cycle or UP brine cycle which ever comes first. Ranges from 1 second to 200 minutes.
- Relay Actuation Gallons: Relay activates after a set number of gallons has passed through the meter when the valve is in the Service mode. Ranges from 1 to 50 gallons.

Press NEXT to go to Step 13S. Press REGEN to return to previous step.

STEP 13S

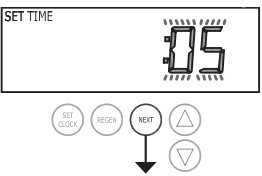

Step 13S: Set Relay Deactivate Time using the ▲ or ▼ buttons.

- If Set Time on is selected in Step 10S the relay will deactivate after the time set has expired. Ranges from 1 second to 200 minutes.
- If Set Gal on is selected in Step 10S the relay will deactivate after the time set has expired or after the meter stops registering flow, whichever comes first. Ranges from 1 second to 20 minutes.

Press NEXT to exit OEM Softener System Setup. Press REGEN to return to previous step.

RETURN TO NORMAL MODE

Table 8
Softener Setting Options

Gallons Capacity	Regeneration Time Option	Day Override	Result ⁸
AUTO	NORMAL	oFF	Reserve capacity automatically estimated. Regeneration occurs when gallons capacity falls below the reserve capacity at the next Regen Set Time.
AUTO	NORMAL	Any number	Reserve capacity automatically estimated. Regeneration occurs at the next Regen Set Time when gallons capacity falls below the reserve capacity or the specified number of days between regenerations is reached.
Any number	NORMAL	oFF	Reserve capacity <u>not</u> automatically estimated. Regeneration occurs at the next Regen Set Time when gallons capacity reaches 0.
oFF	NORMAL	Any number	Reserve capacity <u>not</u> automatically estimated. Regeneration occurs at the next Regen Set Time when the specified number of days between regenerations is reached.
Any number	NORMAL	Any number	Reserve capacity <u>not</u> automatically estimated. Regeneration occurs at the next Regen Set Time when gallons capacity reaches 0 or the specified number of days between regenerations is reached.
AUTO	On O	oFF	Reserve capacity <u>not</u> automatically estimated. Regeneration occurs immediately when gallons capacity reaches 0. Time of regeneration will not be allowed to be set because regeneration will always occur when gallons capacity reaches 0.
Any number	On O	oFF	Reserve capacity <u>not</u> automatically estimated. Regeneration occurs immediately when gallons capacity reaches 0. Time of regeneration will not be allowed to be set because regeneration will always occur on 0.
AUTO	NORMAL on 0	oFF	Reserve capacity automatically estimated. Regeneration occurs when gallons capacity falls below the reserve capacity at the next Regen Set Time or regeneration occurs immediately after 10 minutes of no water usage when gallon capacity reaches 0.
AUTO	NORMAL on 0	Any number	Reserve capacity automatically estimated. Regeneration occurs at the next Regen Set Time when gallons capacity falls below the reserve capacity or the specified number of days between regenerations is reached or regeneration occurs immediately after 10 minutes of no water usage when gallon capacity reaches 0.
Any number	NORMAL on 0	Any number	Reserve capacity <u>not</u> automatically estimated. Regeneration occurs at the next Regen Set Time when the specified number of days between regenerations is reached or regeneration occurs immediately after 10 minutes of no water usage when gallon capacity reaches 0.

⁸Reserve capacity estimate is based on history of water usage.

OEM Filter System Setup

In OEM Filter System Setup the order of the cycles is preset to Backwash, dn Brine, Backwash, dn Brine and then Rinse. All cycles are in minutes and can be set to off.

STEP 1F

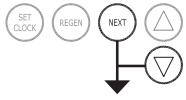

Step 1F – Press NEXT and ▼ simultaneously for 3 seconds and release. If screen in Step 2F does not appear in 5 seconds the lock on the valve is activated. To unlock press ▼, NEXT, ▲, and SET CLOCK in sequence, then press NEXT and ▼ simultaneously for 3 seconds and release.

STEP 2F

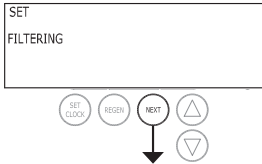

Step 2F – Choose FILTERING using the ▼ or ▲ buttons. Press NEXT to go to Step 3F. Press REGEN to exit OEM Filter System Setup.

STEP 3F

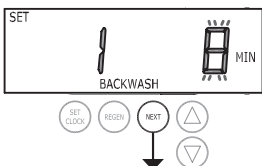

Step 3F – Select the time for the first cycle using the ▼ or ▲ button. Press NEXT to go to Step 4F. Press REGEN to return to previous step.

STEP 4F



Step 4F – Select the time for the second cycle using the ▼ or ▲ button. Press NEXT to go to Step 5F. Press REGEN to return to previous step.

NOTE: The display will flash between cycle number and time, and brine direction (dn or UP).

STEP 5F

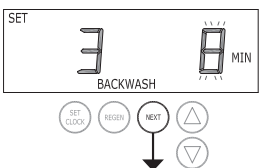

Step 5F – Select the time for the third cycle using the ▼ or ▲ button. Press NEXT to go to Step 6F. Press REGEN to return to previous step.

STEP 6F

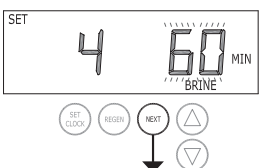

Step 6F – Select the time for the fourth cycle using the ▼ or ▲ button. Verify the correct valve body, main piston and stack are being used and both injector plugs are installed. See Compliance Table in Service Instructions under Injector Cap, Screen, Injector Plug and Injector section and figure 6. Press NEXT to go to Step 7F. Press REGEN to return to previous step.

NOTE: The display will flash between cycle number and time, and brine direction (dn).

STEP 7F



Step 7F – Select the time for the fifth cycle (which in this example is RINSE) using the ▼ or ▲ button. Press NEXT to go to Step 6F. Press REGEN to return to previous step.

STEP 8F

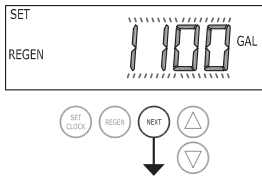

Step 8F – Set Volume Capacity using the ▼ or ▲ button. If value is set to:

- “oFF” regeneration will be based solely on the day override set (see Installer Display/Settings Step 3I); or
- as a number (allowable range 20 to 250,000) regeneration initiation will be based off the value specified. Increment increase is 20 for the range 20 to 2,000, 100 for the range of 2,000 to 10,000, 500 for the range 10,000 to 50,000 and 2,000 for the range of 50,000 to 250,000.

See Table 9 for more detail. Press NEXT to go to Step 9F. Press REGEN to return to previous step.

STEP 9F

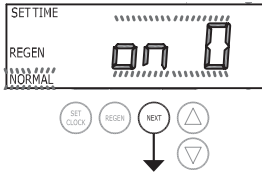

Step 9F – Set Regeneration Time Options using the ▼ or ▲ button. If value is set to:

- “NORMAL” means regeneration will occur at the preset time;
- “on 0” means regeneration will occur immediately when the gallons capacity reaches 0 (zero); or
- “NORMAL + on 0” means regeneration will occur at one of the following:
 - the preset time when the gallons capacity falls below the reserve or the specified number of days between regenerations is reached whichever comes first;
 - or
 - after 10 minutes of no water usage when the gallon capacity reaches 0 (zero).

See Table 9 for more detail. Press NEXT to go to Step 10F. Press REGEN to return to previous step.

STEP 10F

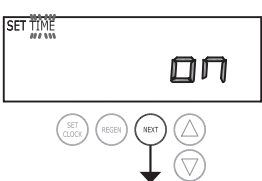

Step 10F: Set Relay operation using the ▲ or ▼ button. The choices are:

- Set Time on: Relay activates after a set time at the beginning of a regeneration and then deactivates after a set period of time. The start of regeneration is defined as the first backwash cycle, Dn brine cycle or UP brine cycle which ever comes first.
- Set Gal on: Relay activates after a set number of gallons has been treated and then deactivates after a set period of time or after the meter stops registering flow, whichever comes first.
- Off: If set to Off, Steps 11F and 12F will not be shown.

Press NEXT to go to Step 11F. Press REGEN to return to previous step.

STEP 11F

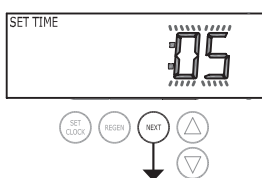

Step 11F: Set Relay Actuation Time or Gallons using the ▲ or ▼ buttons. The choices are:

- Relay Actuation Time: After the start of a regeneration the amount of time that should pass prior to activating the relay. The start of regeneration is defined as the first backwash cycle, Dn brine cycle or UP brine cycle which ever comes first. Ranges from 1 second to 200 minutes.
- Relay Actuation Gallons: Relay activates after a set number of gallons has passed through the meter when the valve is in the Service mode. Ranges from 1 to 50 gallons.

Press NEXT to go to Step 12F. Press REGEN to return to previous step.

STEP 12F

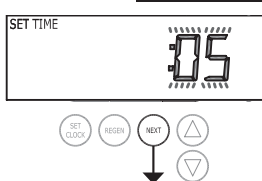

Step 12F: Set Relay Deactivate Time using the ▲ or ▼ buttons.

- If Set Time on is selected in Step 9F the relay will deactivate after the time set has expired. Ranges from 1 second to 200 minutes.
- If Set Gal on is selected in Step 9F the relay will deactivate after the time set has expired or after the meter stops registering flow, whichever comes first. Ranges from 1 second to 20 minutes.

Press NEXT to exit OEM Filter System Setup. Press REGEN to return to previous step.

RETURN TO NORMAL MODE

Table 9

Filter Setting Options

Gallons Capacity	Regeneration Time Option	Day Override	Result
oFF	NORMAL	Any number	Reserve capacity <u>not</u> automatically estimated. Regeneration occurs at the next Regen Set Time when the specified number of days between regenerations is reached.
Any number	NORMAL	oFF	Reserve capacity <u>not</u> automatically estimated. Regeneration occurs at the next Regen Set Time when gallons capacity reaches 0.
Any number	NORMAL	Any number	Reserve capacity <u>not</u> automatically estimated. Regeneration occurs at the next Regen Set Time when gallons capacity reaches 0 or the specified number of days between regenerations is reached.
Any number	On 0	oFF	Reserve capacity <u>not</u> automatically estimated. Regeneration occurs immediately when gallons capacity reaches 0. Time of regeneration will not be allowed to be set because regeneration will always occur on 0.
Any number	NORMAL on 0	Any number	Reserve capacity <u>not</u> automatically estimated. Regeneration occurs at the next Regen Set Time when the specified number of days between regenerations is reached or regeneration occurs immediately after 10 minutes of no water usage when gallon capacity reaches 0.

Installer Display Settings

STEP 1I



STEP 1I - Press NEXT and ▲ simultaneously for 3 seconds.

STEP 2I

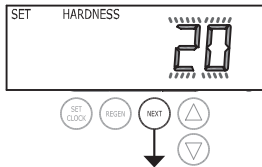

STEP 2I – Hardness: Set the amount of hardness in grains of hardness as calcium carbonate per gallon using the ▼ or ▲ buttons. The default is 20 with value ranges from 1 to 150 in 1 grain increments. Note: The grains per gallon can be increased if soluble iron needs to be reduced. This display will show “-nA-” if “FILTER” is selected in Step 2F or if ‘AUTO’ is not selected in Set Volume Capacity in OEM Softener System Setup. Press NEXT to go to step 3I. Press REGEN to exit Installer Display Settings.

STEP 3I

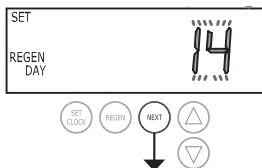

STEP 3I – Day Override: When volume capacity is set to “oFF”, sets the number of days between regenerations. When volume capacity is set to AUTO or to a number, sets the maximum number of days between regenerations. If value set to “oFF”, regeneration initiation is based solely on volume used. If value is set as a number (allowable range from 1 to 28) a regeneration initiation will be called for on that day even if sufficient volume of water were not used to call for a regeneration. Set Day Override using ▼ or ▲ buttons:

- number of days between regeneration (1 to 28); or
- “oFF”.

See Table 8 for more detail on softener setup and Table 9 for more detail on filter setup. Press NEXT to go to step 4I. Press REGEN to return to previous step.

STEP 4I

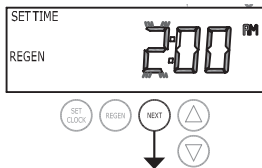

STEP 4I – Next Regeneration Time (hour): Set the hour of day for regeneration using ▼ or ▲ buttons. AM/PM toggles after 12. The default time is 2:00 AM. This display will show “on 0” if “on 0” is selected in Set Regeneration Time Option in OEM Softener System Setup or OEM Filter System Setup. Press NEXT to go to step 5I. Press REGEN to return to previous step.

STEP 5I

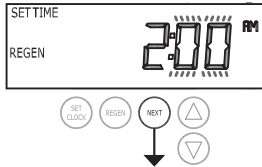

STEP 5I – Next Regeneration Time (minutes): Set the minutes of day for regeneration using ▼ or ▲ buttons. This display will not be shown if “on 0” is selected in Set Regeneration Time Option in OEM Softener System Setup or OEM Filter System Setup. Press NEXT to exit Installer Display Settings. Press REGEN to return to previous step.

RETURN TO
NORMAL MODE

To initiate a manual regeneration immediately, press and hold the “REGEN” button for three seconds. The system will begin to regenerate immediately. The control valve may be stepped through the various regeneration cycles by pressing the “REGEN” button.

User Display Settings

General Operation

When the system is operating, one of five displays may be shown. Pressing NEXT will alternate between the displays. One of the displays is always the current time of day.

The second display is one of the following: days remaining or volume remaining. Days remaining is the number of days left before the system goes through a regeneration cycle. Capacity remaining is the gallons that will be treated before the system goes through a regeneration cycle. When set up as a softener, initial capacity remaining is equal to the (set in OEM Softener Setup) grains capacity divided by the hardness (set in Installer Display Settings) multiplied by 0.88. Pressing the ▼ button while in the Capacity Remaining display will decrease the capacity remaining in 10 gallon increments and will also increase the volume used impacting the recorded values in Diagnostics Steps 3D, 4D and 5D and Valve History, Step 4VH.

The third display shows the current treated water flow rate through the system. The fourth display will show either dP or hold if the dP switch is closed.

The fifth display shows the pounds of salt remaining or flashes “SALT” fill when the calculated pounds of salt falls below a safety level. The fifth display will not appear if the valve is set up as a filter or if the Set Low Salt Warning is set to off (see last step in OEM Softener System Setup). The user can scroll between the displays as desired.

If the system has called for a regeneration that will occur at the preset time of regeneration, the words REGEN TODAY will appear on the display.

If a water meter is installed, the word “Softening” or “Filtering” flashes on the display when water is being treated (i.e. water is flowing through the system).

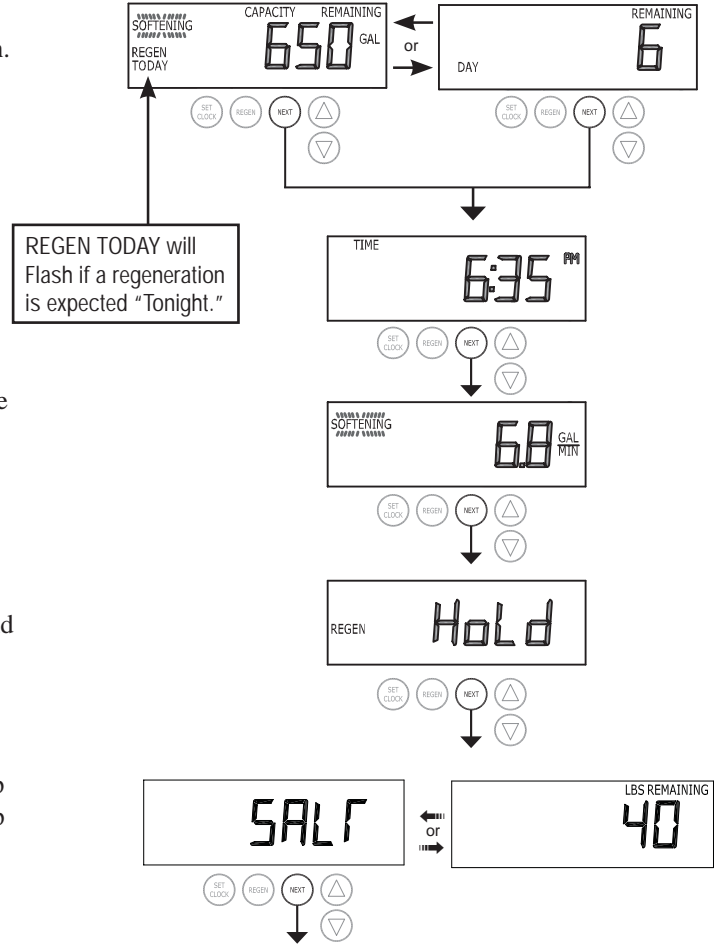

Regeneration Mode

Typically a system is set to regenerate at a time of low water usage. An example of a time with low water usage is when a household is asleep. If there is a demand for water when the system is regenerating, untreated water will be used.

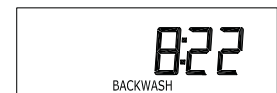

When the system begins to regenerate, the display will change to include information about the step of the regeneration process and the time remaining for that step to be completed. The system runs through the steps automatically and will reset itself to provide treated water when the regeneration has been completed.

Manual Regeneration

Sometimes there is a need to regenerate the system sooner than when the system calls for it, usually referred to as manual regeneration. There may be a period of heavy water usage because of guests or a heavy laundry day.

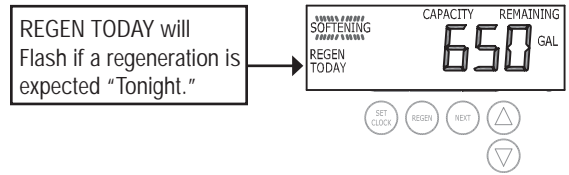

To initiate a manual regeneration at the preset delayed regeneration time, when the regeneration time option is set to “NORMAL” or “NORMAL + on 0”, press and release “REGEN”. The words “REGEN TODAY” will flash on the display to indicate that the system will regenerate at the preset delayed regeneration time. If you pressed the “REGEN” button in error, pressing the button again will cancel the request. Note: If the regeneration time option is set to “on 0” there is no set delayed regeneration time so “REGEN TODAY” will not activate if “REGEN” button is pressed.

To initiate a manual regeneration immediately, press and hold the “REGEN” button for three seconds. The system will begin to regenerate immediately. The request cannot be cancelled.

Note: For softeners, if the brine tank does not contain salt, fill with salt and wait at least two hours before regenerating.

Set Time of Day

The user can also set the time of day. Time of day should only need to be set if the battery has been depleted because of extended power outages or when daylight saving time begins or ends. If an extended power outage occurs, the time of day will flash on and off which indicates the time of day should be reset. The non rechargeable battery should also be replaced.

STEP 1U

STEP 1U – Press SET CLOCK.



STEP 2U

STEP 2U - Current Time (hour): Set the hour of the day using ▼ or ▲ buttons. AM/PM toggles after 12. Press NEXT to go to Step 3U.

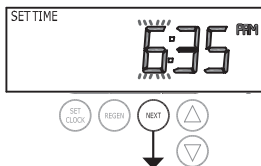

STEP 3U

STEP 3U - Current Time (minutes): Set the minutes of the day using ▼ or ▲ buttons. Press NEXT to exit Set Time of Day. Press REGEN to return to previous step.

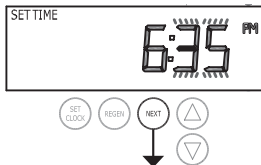

RETURN TO NORMAL MODE

Salt Remaining or Adding Salt

If the Low Salt Warning was activated in the last step of OEM Softener System Setup, the following screens will be viewed in the User Display.

Note: The salt used per regeneration setting can be set in increments of 0.1 pounds, but the LBS REMAINING screen will round up or down to the closest whole number.

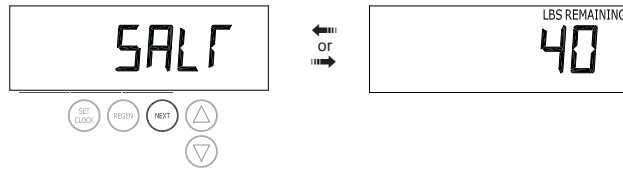

Once the salt remaining has gone below the set point the display will automatically flash Salt Fill.



When adding salt to the brine tank (if the salt remaining feature is activated) the following steps must be completed:

STEP 1US



Step 1US – Press the NEXT button until SALT appears in the display. It does not matter if the SALT display alternates with the LBS REMAINING display.

STEP 2US



Step 2US – Press SET CLOCK.

STEP 3US



Step 3US – Set LBS REMAINING: Use the ▼ or ▲ button to adjust the pounds remaining in the brine tank.

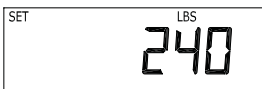

NOTE: Estimate the pounds of salt in the brine tank and add it to the amount of salt added to the brine tank. The example at the left would indicate 200 lbs. of salt being added to a brine tank that has 40 lbs. remaining.

STEP 4US



Step 4US – Press SET CLOCK to exit Adding Salt.

RETURN TO NORMAL MODE

Power Loss

If the power goes out the system will keep time until the battery is depleted. If an extended power outage occurs, the time of day will flash on and off which indicates the time of day should be reset and the battery replaced. The system will remember the rest.

Error Message

If the word “ERROR” and a number or the word LoFlo are alternately flashing on the display contact the OEM for help. A number indicates that the valve was not able to function properly. The word LoFlo indicates there is probably a leak somewhere in the plumbing.

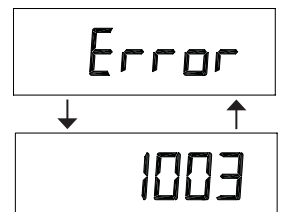

Diagnostics

STEP 1D



STEP 1D – Press ▲ and ▼ simultaneously for three seconds. If screen in step 2D does not appear in 5 seconds the lock on the valve is activated. To unlock press ▲, NEXT, ▼, and SET CLOCK in sequence, then press ▲ and ▼ simultaneously for 3 seconds.

STEP 2D

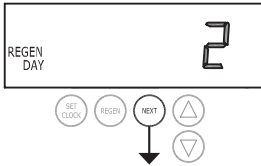

STEP 2D – Days, since last regeneration: This display shows the days since the last regeneration occurred. Press the NEXT button to go to Step 3D. Press REGEN to exit Diagnostics.

STEP 3D

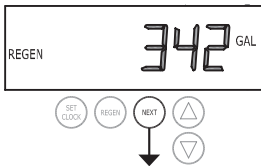

STEP 3D – Volume, since last regeneration: This display shows the volume of water that has been treated since the last regeneration. This display will equal zero if a water meter is not installed. Press the NEXT button to go to Step 4D. Press REGEN to return to previous step.

STEP 4D

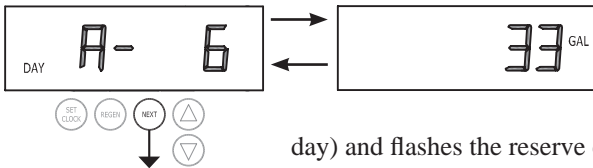

STEP 4D – Volume, reserve capacity used for last 7 days: If the valve is set up as a softener, a meter is installed and Set Volume Capacity is set to “Auto,” this display shows 0 day (for today) and flashes the reserve capacity. Pressing the ▲ button will show day 1 (which would be yesterday) and flashes the reserve capacity used. Pressing the ▲ button again will show day 2 (the day before yesterday) and the reserve capacity. Keep pressing the ▲ button to show the capacity for days 3, 4, 5 and 6. The ▼ button can be pressed to move backwards in the day series. Press the NEXT button at any time to go to Step 5D. Press REGEN to return to previous step.

STEP 5D

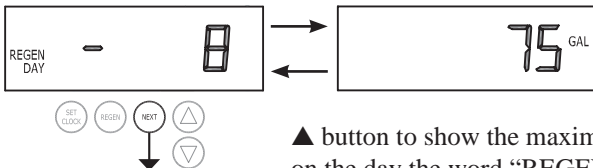

STEP 5D - Volume, 63-day usage history: This display shows day 1 (for yesterday) and flashes the volume of water treated yesterday. Pressing the ▲ button will show day 2 (which would be the day before yesterday) and flashes the volume of water treated on that day. Continue to press the ▲ button to show the maximum volume of water treated for the last 63 days. If a regeneration occurred on the day the word “REGEN” will also be displayed. This display will show dashes if a water meter is not installed. Press the NEXT button at any time to go to Step 6D. Press REGEN to return to previous step.

STEP 6D

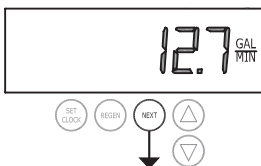

STEP 6D – Flow rate, maximum last seven days: The maximum flow rate in gallons per minute that occurred in the last seven days will be displayed. This display will equal zero if a water meter is not installed. Press the NEXT button to exit Diagnostics. Press REGEN to return to previous step.

RETURN TO NORMAL MODE

When desired, all information in Diagnostics may be reset to zero when the valve is installed in a new location. To reset to zero, press NEXT and ▼ buttons simultaneously to go to the Service/OEM 1 screen, and release. Press ▲ and ▼ simultaneously to reset diagnostic values to zero. Screen will return to User Display.

Valve History

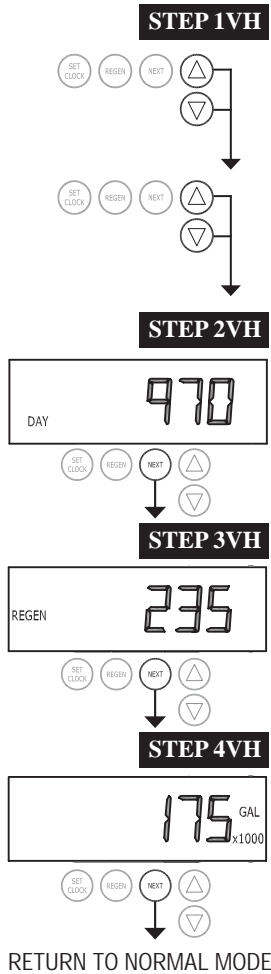

STEP 1VH – Press ▲ and ▼ simultaneously for three seconds and release. Then press ▲ and ▼ simultaneously and release. If screen in step 2VH does not appear in 5 seconds the lock on the valve is activated. To unlock press ▼, NEXT, ▲, and SET CLOCK in sequence, then press ▲ and ▼ simultaneously for 3 seconds and release. Then press ▲ and ▼ simultaneously and release.

STEP 2VH⁹ – Days, total since start-up: This display shows the total days since startup. Press the NEXT button to go to Step 3VH. Press REGEN to return to previous step.

STEP 3VH – Regenerations, total number since start-up: This display shows the total number of regenerations that have occurred since startup. Press the NEXT button to go to Step 4VH. Press REGEN to return to previous step.

STEP 4VH – Volume, total used since start-up: This display shows the total gallons treated since startup. This display will equal zero if a water meter is not installed. Press the NEXT button to exit Valve History. Press REGEN to return to previous step.

⁹ Values in steps 2VH through 4VH cannot be reset.

Installation

Refill Flow Control Assembly or Refill Port Plug

Control valves that are setup for backwash only come equipped with a refill port plug. The refill port plug has no regenerant line connection.

Control valves that use a regenerant come equipped with a 3/8" refill flow control assembly. To switch to the 1/2" refill flow control assembly, remove the refill flow control and retainer (from the 3/8" refill elbow) by twisting and pulling out. Insert the refill flow control and retainer into the 1/2" refill elbow.

To complete the regenerant line connection, orientate the outlet in the desired direction and push the plastic insert into the polytube. Push the polytube into the nut. Do not use pipe dope or other sealants on threads. The threads for the compression nut do not need Teflon tape. Tighten the nut securely to create a pressure tight connection. A pliers or crescent wrench may be used to tighten or unscrew the nut. The nut, gripper and retainer sleeve is a 3 piece assembly that can come apart if removed from the elbow body. Parts must be reassembled exactly as shown in refill flow control assembly drawing to function properly. If the nut is completely removed from the body, slip the nut, plastic gripper and retainer sleeve on to the tube then tighten on to the fitting.

Drain Line Flow Control and Fitting Assembly

To determine which drain line flow control to use, obtain media bed expansion tables from the media manufacturer, choose a water temperature and look up the desired backwash rate per square foot of bed area. Then calculate the backwash rate using the desired tank diameter. Using Table 7, choose the drain line flow control that has the backwash flow rate closest to the calculated backwash rate. If a manufacturer chooses to use an external drain line flow control, use an elbow fitting that does not contain a hole.

If the drain line is a 5/8" flexible polytube, slide the nut onto the polytube, then place the polytube insert into the end of the polytube and tighten the nut on to the 3/4" drain line fitting. The nut is only designed for use with flexible polytube. Use other nuts if attaching different materials.

To access the drain line flow control remove the locking clip by pulling it straight out. Pull fitting out and replace the locking clip so that it is not misplaced. The drain line fitting is pressed in and has an o-ring seal.

In the 3/4" elbow, the white flow control retainer is pressed in and has an o-ring seal. The retainer can be removed by rotating and pulling. The flow control can be removed by prying upward with a small blade flat screwdriver in one of the slots on the side. The drain line flow control and retainer can be chemically cleaned in dilute sodium bisulfite or vinegar, or replaced. Do not use a wire brush to clean the flow control or the washer. The washers are identified with three numbers, which correspond to the flow rate. When reinstalling make sure the identifying number and the rounded inside diameter on the washer is visible when seated in the retainer. The white flow control washer retainer can also be removed and cleaned. Push the retainer in firmly when reinstalling.

In the 1" straight fitting, the retainer is the fitting. Unscrew the nut to access the flow control. The drain line flow control and the fitting can be chemically cleaned or replaced. Do not use a wire brush to clean the flow control or the fitting.

Do not use Vaseline, oils, or other unacceptable lubricants on o-rings. A silicone lubricant may be used on the black o-ring. Use a pliers or crescent wrench to tighten or unscrew the nut. Do not use a pipe wrench to tighten or loosen nut. Do not use pipe dope or other sealants on threads. Use Teflon tape on the threads of the drain line control fitting when installing 3/4" NPT or 1" straight fitting.

Installation Fitting Assemblies

The installation fittings connect to the control valve or the bypass valve using nuts that only require hand tightening. Hand tighten nut connections between control valve and installation fittings, control valve and bypass valve, and bypass valve and installation fittings allow for easy serviceability. Do not use a pipe wrench to tighten nuts on installation fittings. Hand tighten only.

The split ring retainer design holds the nut on and allows load to be spread over the entire nut surface area, reducing the chance for leakage. The split ring design, incorporated into the installation fittings allows approximately 2 degrees off axis alignment to the plumbing system. The installation fittings are designed to accommodate minor plumbing misalignments but are not designed to support the weight of a system or the plumbing.

When assembling the installation fitting package, connect the fitting to the plumbing system first and then attach the nut, split ring and o-ring. Heat from soldering or solvent cements may damage the nut, split ring or o-ring. Solder joints should be cool and solvent cements should be set before installing the nut, split ring and o-ring. Avoid getting primer and solvent cement on any part of the o-rings, split rings, bypass valve or control valve. Solvent cements and primers should be used in accordance with the manufacturer's instructions.

Slip the nut onto the fitting first, then the split ring second and the o-ring last. Hand tighten the nut. If the fitting is leaking tightening the nut will not stop the leak. Remove the nut, remove the fitting, and check for damage or misalignment of the o-ring.

Do not use pipe dope or other sealant on threads. Use teflon tape on threaded inlet, outlet and drain fittings. Teflon tape is not necessary on the nut connection or caps because of o-ring seals.

Do not use Vaseline, oils, or other unacceptable lubricants on o-rings. A silicone lubricant may be used on black o-rings.

Bypass Valve

The bypass valve easily connects to the control valve body using nuts that only require hand tightening. Hand tighten nut connections between control valve and fittings, control valve and bypass valve, and bypass valve and installation fittings allow for easy serviceability. The split ring retainer design holds the nut on and allows load to be spread over the entire nut surface area, reducing the chance for leakage. The split ring design incorporated into the bypass allows approximately 2 degrees off axis alignment to the plumbing system. The bypass is designed to accommodate minor plumbing misalignments but is not designed to support the weight of a system or the plumbing.

Avoid getting primer and solvent cements on any part of the o-rings or split rings, bypass valve or control valve. Do not use pipe dope or other sealant on threads. Teflon tape is not necessary on the caps because of o-ring seals.

Do not use Vaseline, oils, or other unacceptable lubricants on o-rings. A silicone lubricant may be used on black o-rings.

Mixing Valve

The mixing valve is an option on the control valve. If the control valve is ordered with a mixing valve it will be installed in the control valve assembly process.

To adjust the blended water, close the mixing valve. Open a water faucet to the desired flow rate. Open the mixing valve until the desired hardness is reached. Close the faucet.

Note: The use of the mixing valve requires modification to the valve body. These modifications should not be done in the field.

Drawings and Part Numbers

WS1ER & WS1.25 LER Front Cover and Drive Assembly

Drawing No.	Order No.	Description	Quantity
1	V3381-01EG	WS1ER Front Cover Assembly Black/Gold	1
	V3381-01ES	WS1ER Front Cover Assembly Black/Silver	
2	V3107-01	WS1 Motor	1
3	V3106-01	WS1 Drive Bracket & Spring Clip	1
4	V3491ER	WS1/1.25/1.5/2LER PC Board	1
5	V3110	WS1 Drive Gear 12x36	3
6	V3109	WS1 Drive Gear Cover	1
Not Shown	V3186	WS1 AC ADAPTER 110V-12V	1
	V3186EU	WS1 AC ADAPTER 220-240V-12V EU	
	V3186UK	WS1 AC ADAPTER 220-240V-12V UK	
	V3186-01	WS1 AC ADAPTER CORD ONLY	

Relay Specifications: To insure proper fit and correct operation the following relay and relay socket manufactured by Idec or the exact equivalent should be used.

Relay No.	Idec Model and Description
Relay Socket	SH3B-05C 3 pole finger safe rail mount socket
Relay	RH2LB-U-AC12V 12vac, DPDT magnetic latching relay

The relay supplies 2 sets of dry contacts for user applications. The wiring of these contacts is application specific.

Wiring For Correct On/Off Operation	
PC Board Relay Terminal Block	Relay Socket
SET	#13
COM	#12 and #14
RES	#9

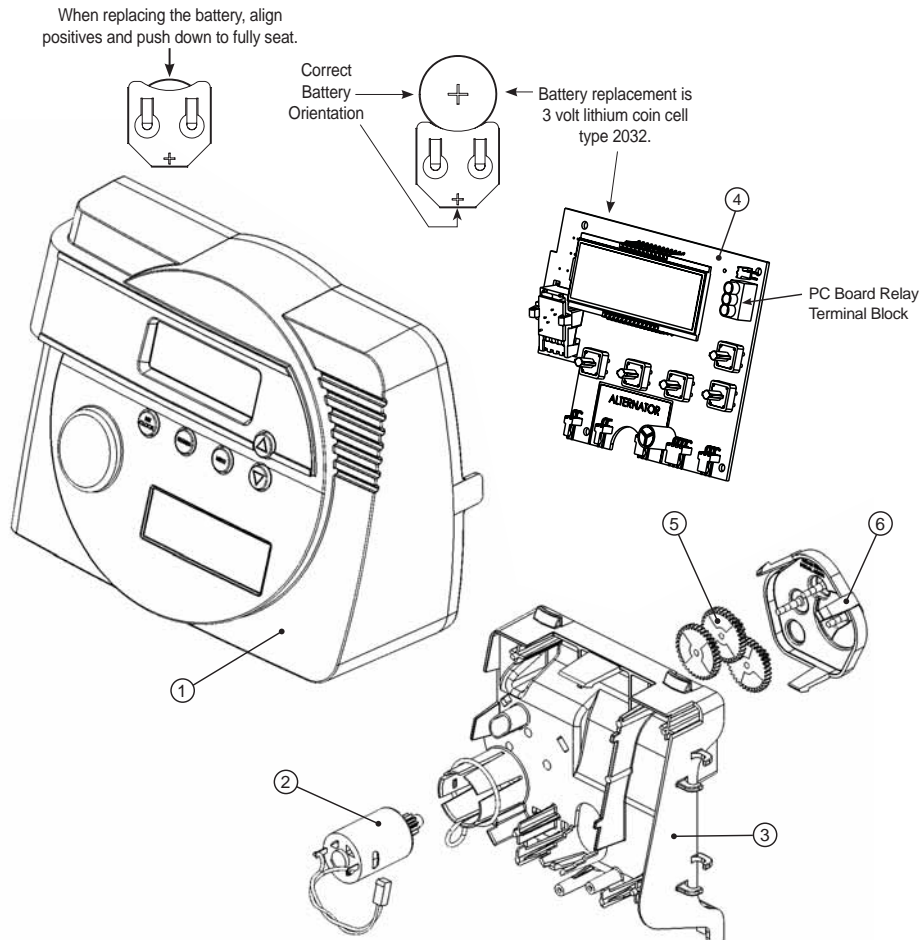

WS1ER Drive Cap Assembly, Downflow Piston, Upflow Piston, Regenerant Piston and Spacer Stack Assembly

Drawing No.	Order No.	Description	Quantity
1	V3005	WS1 Spacer Stack Assembly	1
2	V3004	Drive Cap ASY	1
3	V3382	WS1ER Drive Back Plate	1
4a	V3011*	WS1 Piston Downflow ASY	1
4b	V3011-01*	WS1 Piston Upflow ASY	
5	V3174	WS1 Regenerant Piston	1
6	V3135	O-ring 228	1
7	V3180	O-ring 337	1
8	V3105	O-ring 215 (Distributor Tube)	1
Not Shown	V3001	WS1 Body ASY Downflow	1
	V3001-02	WS1 Mixing Valve Body ASY	
	V3001UP	WS1 Body ASY Upflow	
	V3001-02UP	WS1 Mixing Valve Body Upflow ASY	

*V3011 is labeled with DN and V3011-01 is labeled with UP.
 Note: The regenerant piston is not used in backwash only applications.

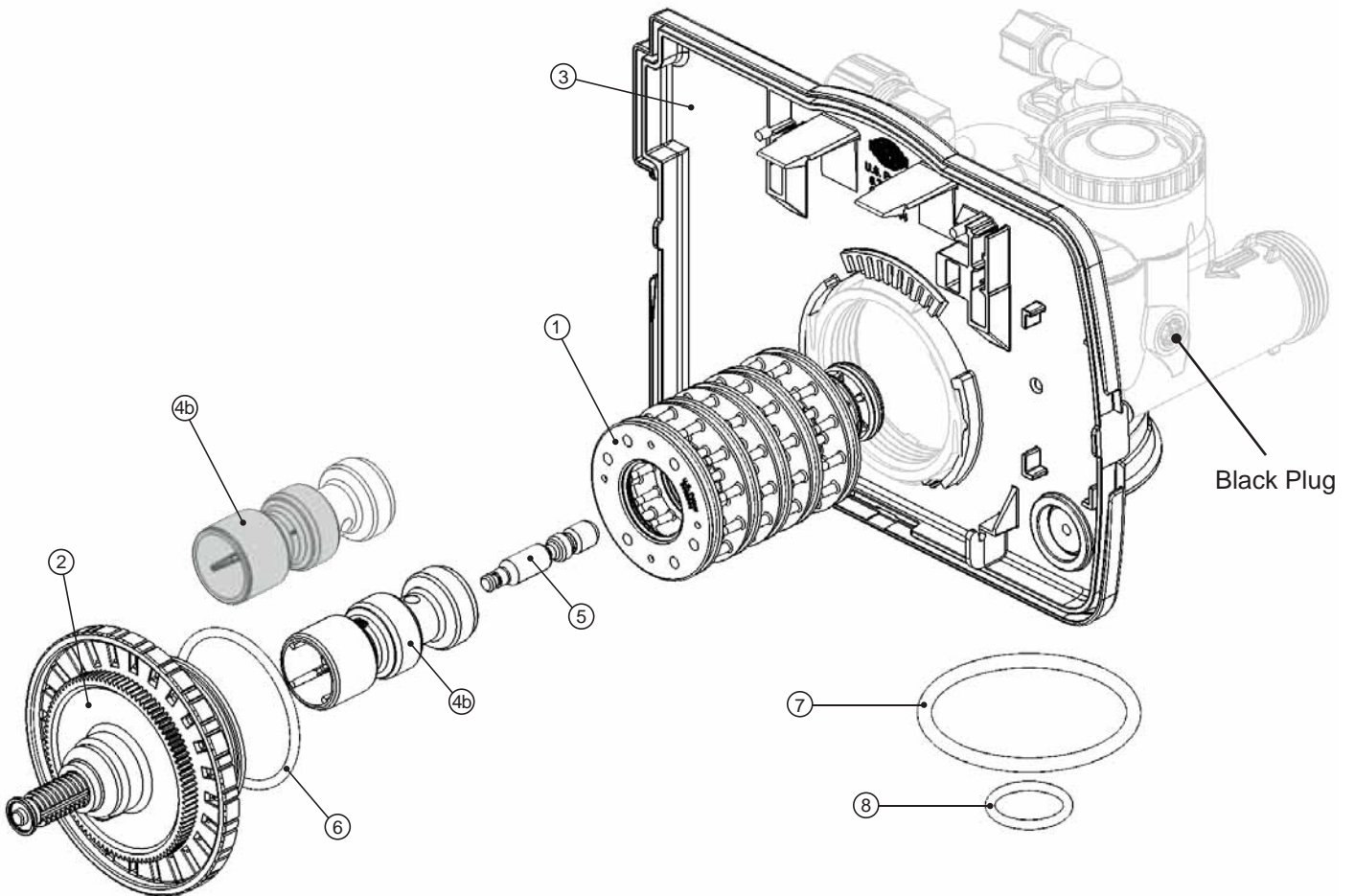

WS1.25ER Drive Cap Assembly, Downflow Piston, Regenerant Piston and Spacer Stack Assembly

Drawing No.	Order No.	Description	Quantity
1	V3430	WS1.5 Spacer Stack Assembly	1
2	V3004	Drive Cap ASY	1
3	V3382	WS1ER Drive Back Plate	1
4	V3407	WS1.5 Piston Downflow ASY	1
5	V3174	WS1 Regenerant Piston	1
6	V3135	O-ring 228	1
7	V3180	O-ring 337	1
8	V3358	O-ring 219 (Distributor Tube Opening 1.32")	1
	V3357	O-ring 218 (Distributor Tube Opening 32mm)	
Not Shown	V3020	WS1.25 Body ASY Downflow (Distributor Tube Opening 1.32")	1
	V3020-01	WS1.25 Mixing Valve Body Downflow ASY (Distributor Tube Opening 1.32")	
	V3020-02	WS1.25 Body ASY Downflow (Distributor Tube Opening 32mm)	
	V3020-03	WS1.25 Mixing Valve Body Downflow ASY (Distributor Tube Opening 32mm)	

Note: The regenerant piston is not used in backwash only applications.

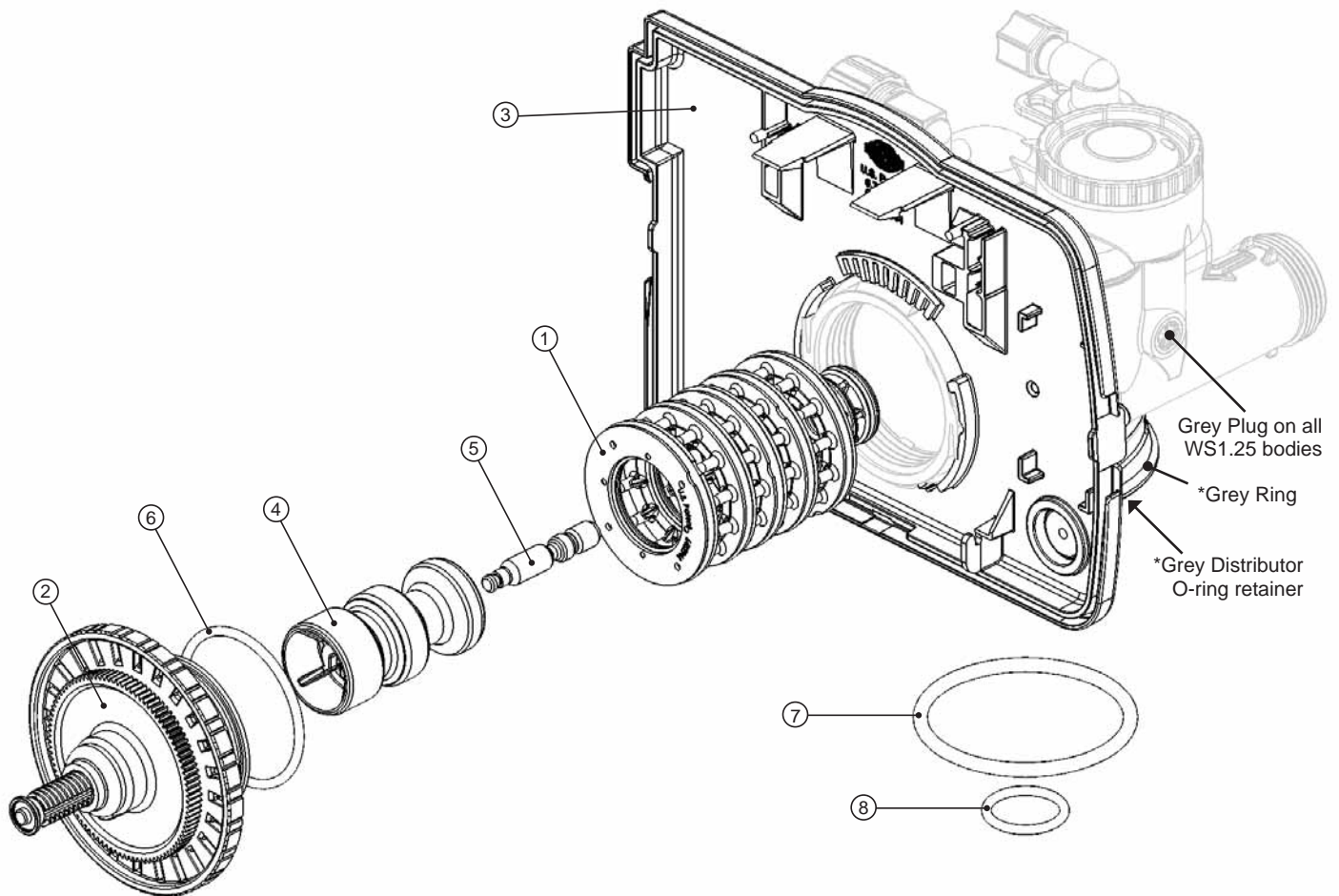

*Only for valves that have a 32mm Distributor Tube Opening

Injector Cap, Injector Screen, Injector, Plug and O-Ring

Drawing No.	Order No.	Description	Quantity
1	V3176	INJECTOR CAP	1
2	V3152	O-RING 135	1
3	V3177-01	INJECTOR SCREEN CAGE	1
4	V3010-1Z	WS1 INJECTOR ASY Z PLUG	1
5	V3010-1A	WS1 INJECTOR ASY A BLACK	1
	V3010-1B	WS1 INJECTOR ASY B BROWN	
	V3010-1C	WS1 INJECTOR ASY C VIOLET	
	V3010-1D	WS1 INJECTOR ASY D RED	
	V3010-1E	WS1 INJECTOR ASY E WHITE	
	V3010-1F	WS1 INJECTOR ASY F BLUE	
	V3010-1G	WS1 INJECTOR ASY G YELLOW	
	V3010-1H	WS1 INJECTOR ASY H GREEN	
	V3010-1I	WS1 INJECTOR ASY I ORANGE	
	V3010-1J	WS1 INJECTOR ASY J LIGHT BLUE	
V3010-1K	WS1 INJECTOR ASY K LIGHT GREEN		
Not Shown	V3170	O-RING 011	*
Not Shown	V3171	O-RING 013	*

* The injector plug and the injector each contain one 011 (lower) and 013 (upper) o-ring.

Note: For upflow position, injector is located in the up hole and injector plug is in the other hole. WS1ER upflow bodies are identified by having the DN marking removed. For a filter that only backwashes, injector plugs are located in both holes.

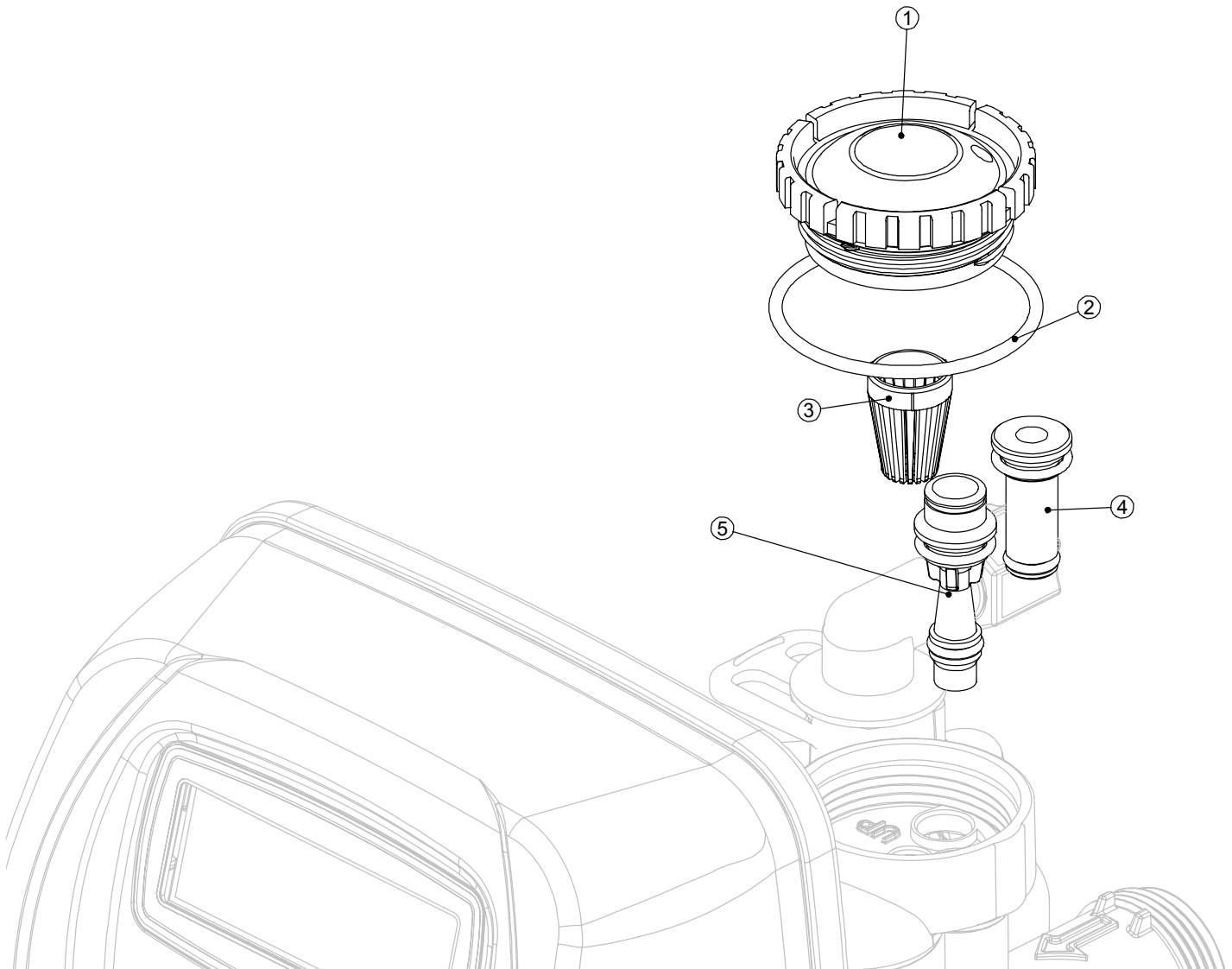

Refill Flow Control Assembly and Refill Port Plug

Drawing No.	Order No.	Description	Quantity
1	V3195-01	WS1 Refill Port Plug Assy	This part is required for backwash only systems
2	H4615	Elbow Locking Clip	1
3	JCP-P-6	Polytube insert 3/8"	1
4	JCPG-6PBLK	Nut 3/8"	1
5	H4613	Elbow Cap 3/8"	1
6	V3163	O-ring 019	1
7	V3165-01*	WS1 RFC Retainer Assy	1
8	V3182	WS1 RFC	1
9	V3330-01	WS1 Brine Elbow Assy w/RFC 3/8"	1
Not Shown	V3552	WS1 Brine Elbow Assy w/RFC 1/2"	1
Not Shown	H4650	Elbow 1/2" with nut and insert	Option

*Assembly includes V3182 WS1 RFC.

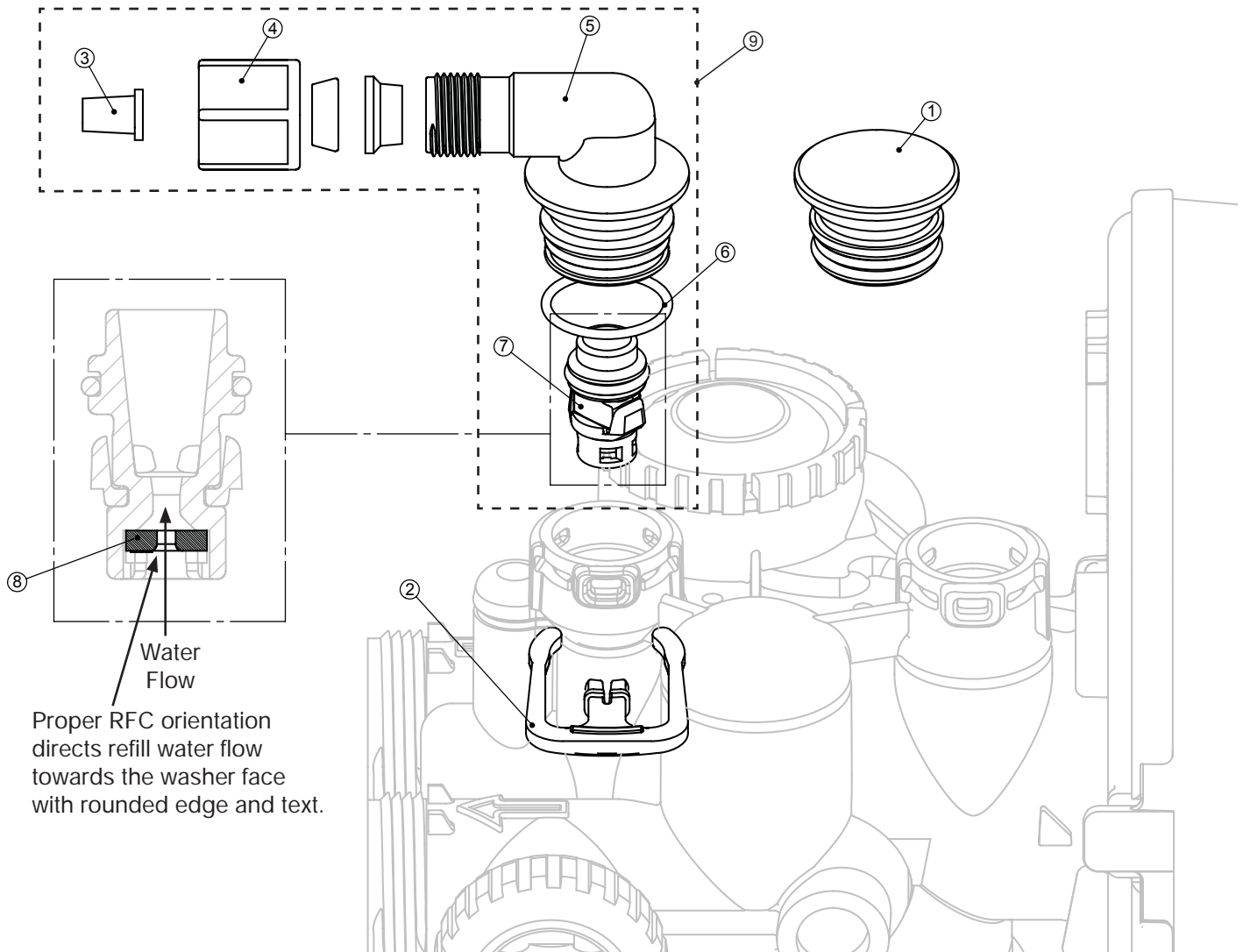

Drain Line – 3/4"

Drawing No.	Order No.	Description	Quantity
1	H4615	Elbow Locking Clip	1
2	PKP10TS8-BULK	Polytube insert 5/8	Option
3	V3192	WS1 Nut 3/4 Drain Elbow	Option
4*	V3158-01	WS1 Drain Elbow 3/4 Male	1
5	V3163	O-ring 019	1
6*	V3159-01	WS1 DLFC Retainer ASY	1
7	V3162-007	WS1 DLFC 0.7 gpm for 3/4	One DLFC must be used if 3/4 fitting is used
	V3162-010	WS1 DLFC 1.0 gpm for 3/4	
	V3162-013	WS1 DLFC 1.3 gpm for 3/4	
	V3162-017	WS1 DLFC 1.7 gpm for 3/4	
	V3162-022	WS1 DLFC 2.2 gpm for 3/4	
	V3162-027	WS1 DLFC 2.7 gpm for 3/4	
	V3162-032	WS1 DLFC 3.2 gpm for 3/4	
	V3162-042	WS1 DLFC 4.2 gpm for 3/4	
	V3162-053	WS1 DLFC 5.3 gpm for 3/4	
	V3162-065	WS1 DLFC 6.5 gpm for 3/4	
	V3162-075	WS1 DLFC 7.5 gpm for 3/4	
	V3162-090	WS1 DLFC 9.0 gpm for 3/4	
	V3162-100	WS1 DLFC 10.0 gpm for 3/4	

*4 and 6 can be ordered as a complete assembly - V3331 WS1 Drain Elbow and Retainer Asy

Valves are shipped without drain line flow control (DLFC) - install DLFC before using. Valves are shipped without 3/4 nut for drain elbow (polytube installation only) and 5/8" polytube insert (polytube installation only).

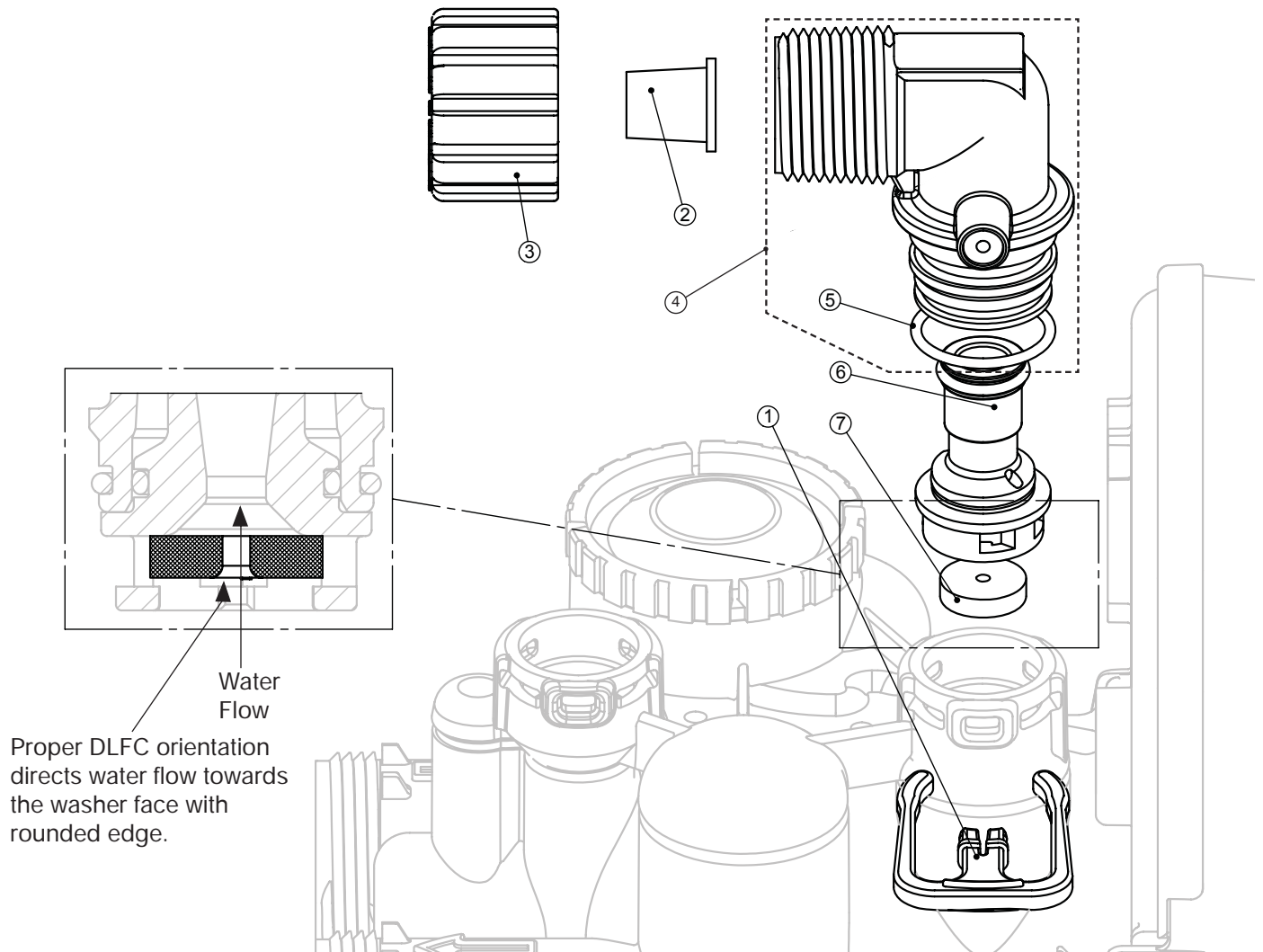

Drain Line – 1”

Drawing No.	Order No.	Description	Quantity
1	H4615	Elbow Locking Clip	1
2	V3008-02	WS1 Drain FTG 1 Straight	1
3*	V3166	WS1 Drain FTG Body 1	1
4*	V3167	WS1 Drain FTG Adapter 1	1
5*	V3163	O-ring 019	1
6*	V3150	WS1 Split Ring	1
7*	V3151	WS1 Nut 1” QC	1
8*	V3105	O-ring 215	1
9	V3190-090	WS1 DLFC 9.0 gpm for 1	One DLFC must be used if 1” fitting is used
	V3190-100	WS1 DLFC 10.0 gpm for 1	
	V3190-110	WS1 DLFC 11.0 gpm for 1	
	V3190-130	WS1 DLFC 13.0 gpm for 1	
	V3190-150	WS1 DLFC 15.0 gpm for 1	
	V3190-170	WS1 DLFC 17.0 gpm for 1	
	V3190-200	WS1 DLFC 20.0 gpm for 1	
V3190-250	WS1 DLFC 25.0 gpm for 1		

* Can be ordered as a set. Order number V3008-02, description: WS1 Drain FTG 1 Straight.

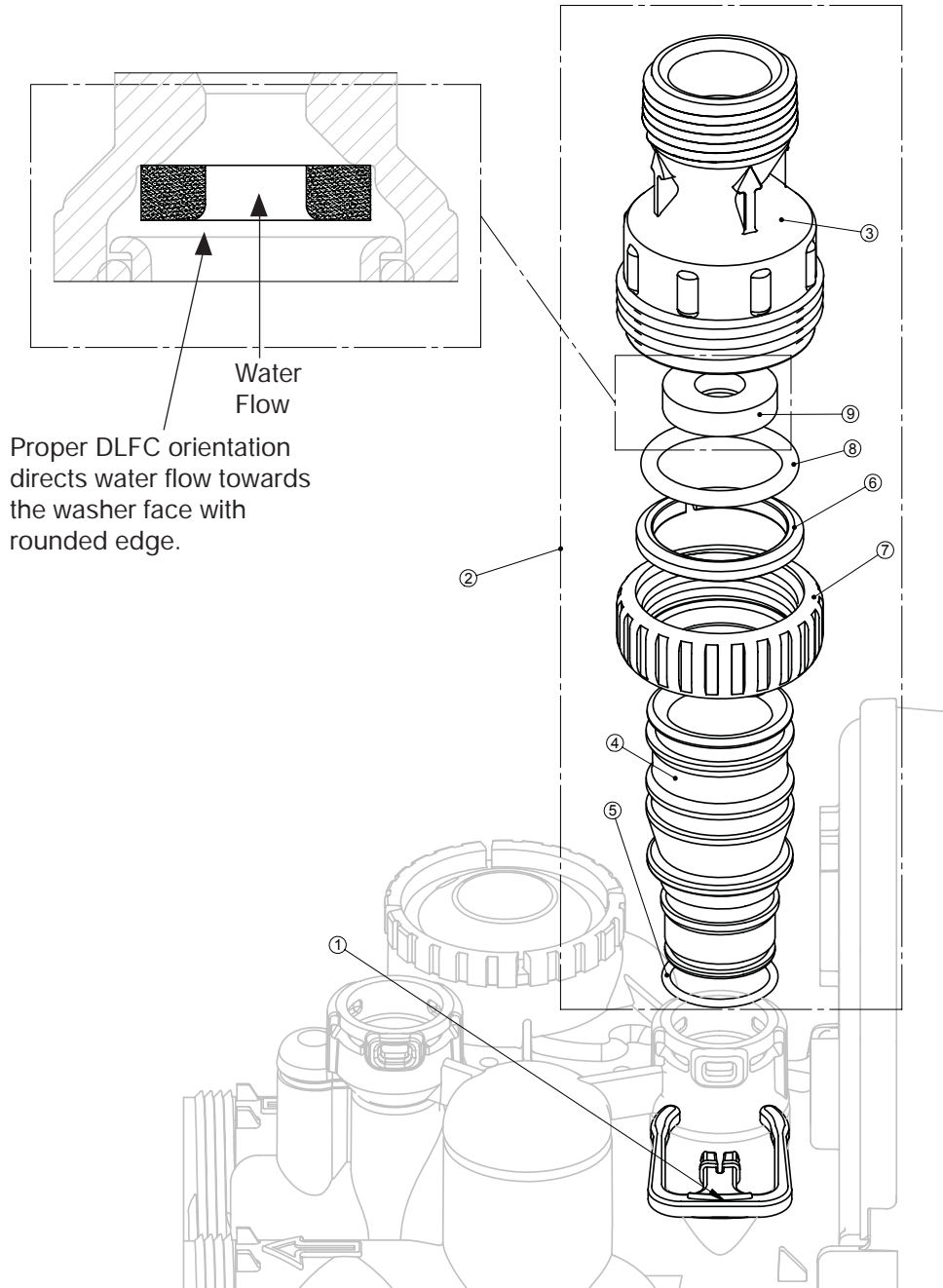

Water Meter, Meter Plug and Mixing Valve

Drawing No.	Order No.	Description	Quantity
1	V3151	WS1 Nut 1" QC	1
2	V3003*	WS1 Meter ASY	1
3	V3118-01	WS1 Turbine ASY	1
4	V3105	O-ring 215	1
5	V3003-01	WS1 Meter Plug ASY	1
6	V3013	Mixing Valve	Optional

*Order number V3003 includes V3118-01 WS1 Turbine ASY and V3105 O-ring 215.

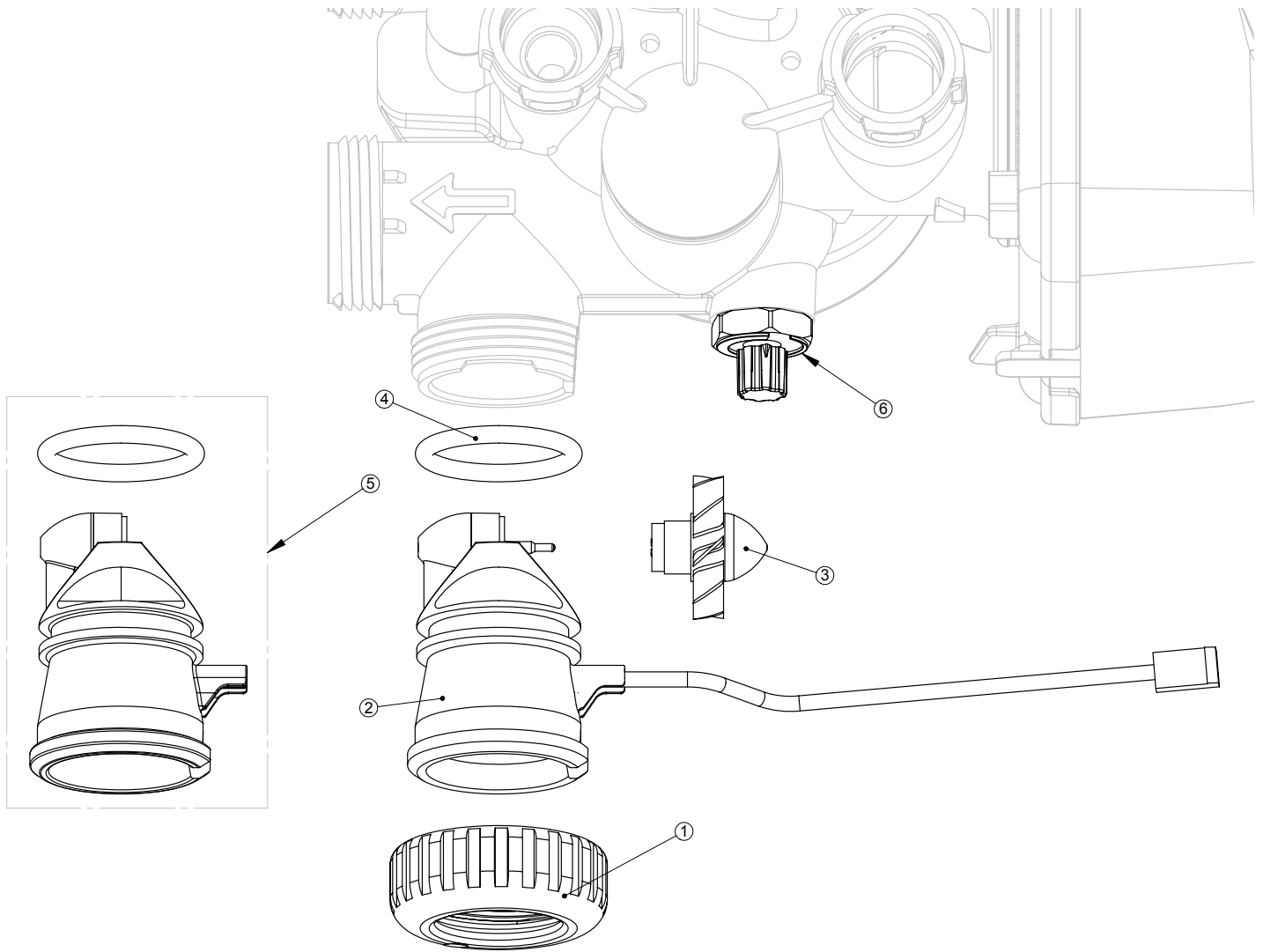

THIS WATER METER SHOULD NOT BE USED AS THE PRIMARY MONITORING DEVICE FOR CRITICAL HEALTH EFFECT APPLICATIONS.

Bypass Valve

Drawing No.	Order No.	Description	Quantity
1	V3151	WS1 Nut 1" Quick Connect	2
2	V3150	WS1 Split Ring	2
3	V3105	O-Ring 215	2
4	V3145	WS1 Bypass 1" Rotor	2
5	V3146	WS1 Bypass Cap	2
6	V3147	WS1 Bypass Handle	2
7	V3148	WS1 Bypass Rotor Seal Retainer	2
8	V3152	O-ring 135	2
9	V3155	O-ring 112	2
10	V3156	O-ring 214	2

(Not Shown) Order No. V3191-01, Description: WS1 Bypass Vertical Adapter Assembly

Order No.	Description	Quantity
V3151	WS1 Nut 1" Quick Connect	2
V3150	WS1 Split Ring	2
V3105	O-Ring 215	2
V3191	WS1 Bypass Vertical Adapter	2

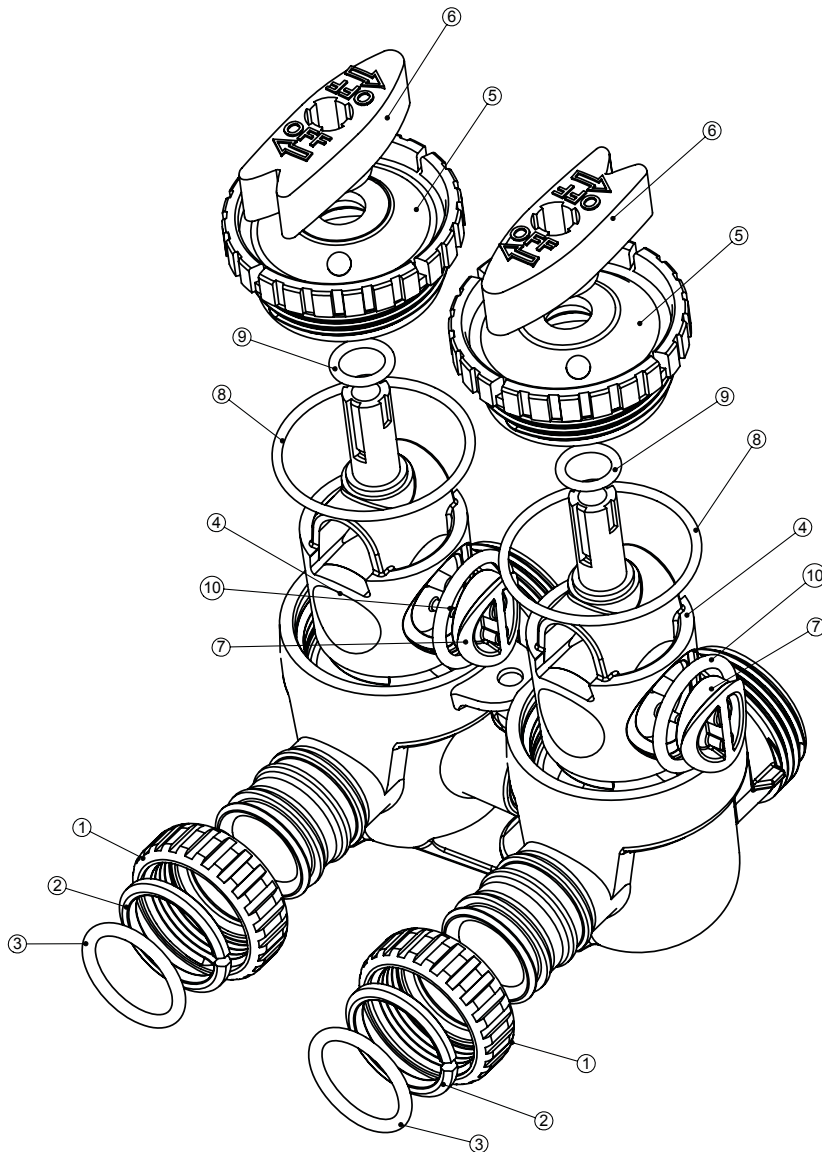

Flow Diagrams – Service and Backwash

flow diagram...service

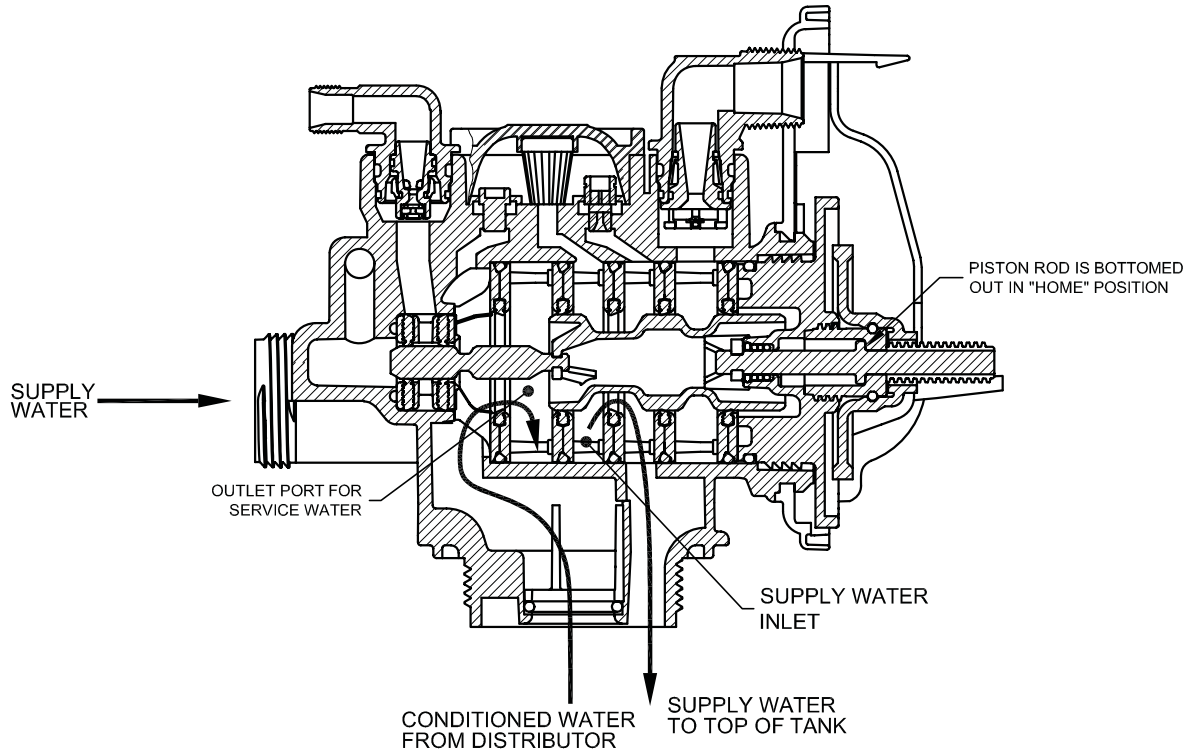

flow diagram...backwash

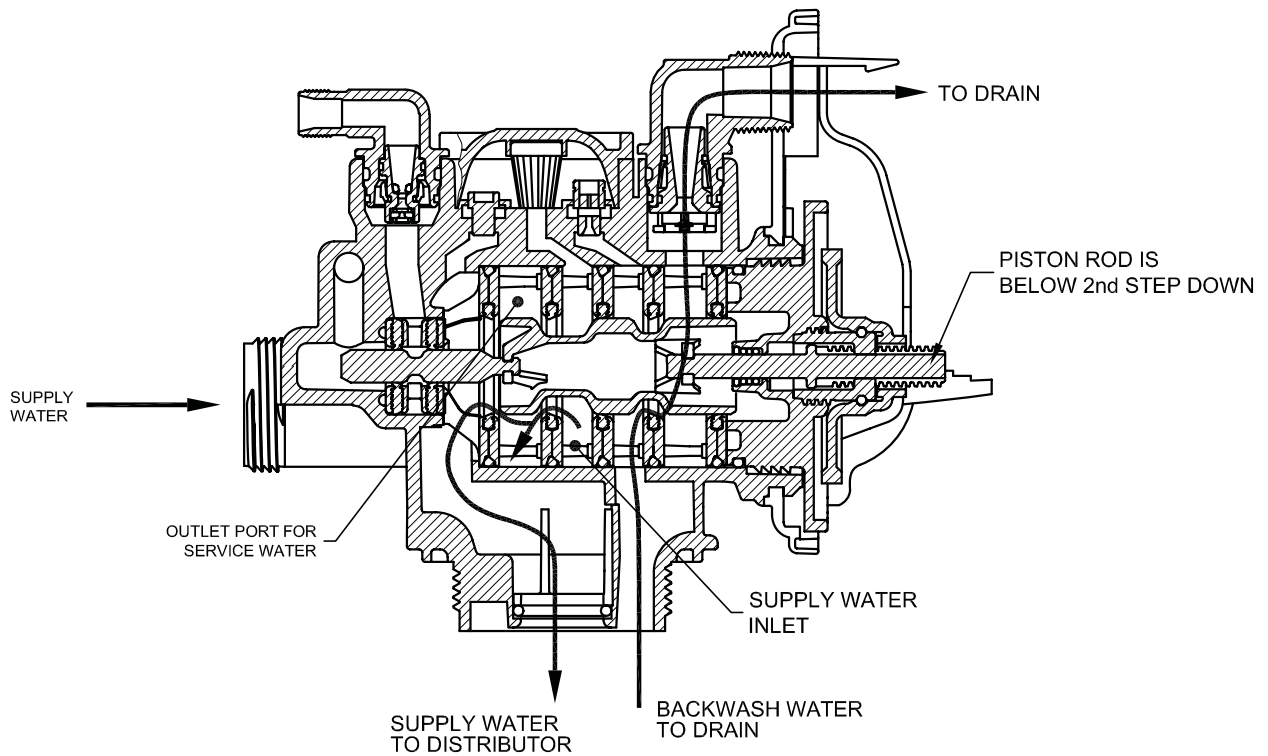

Flow Diagrams – Downflow and Upflow

flow diagram...downflow brine

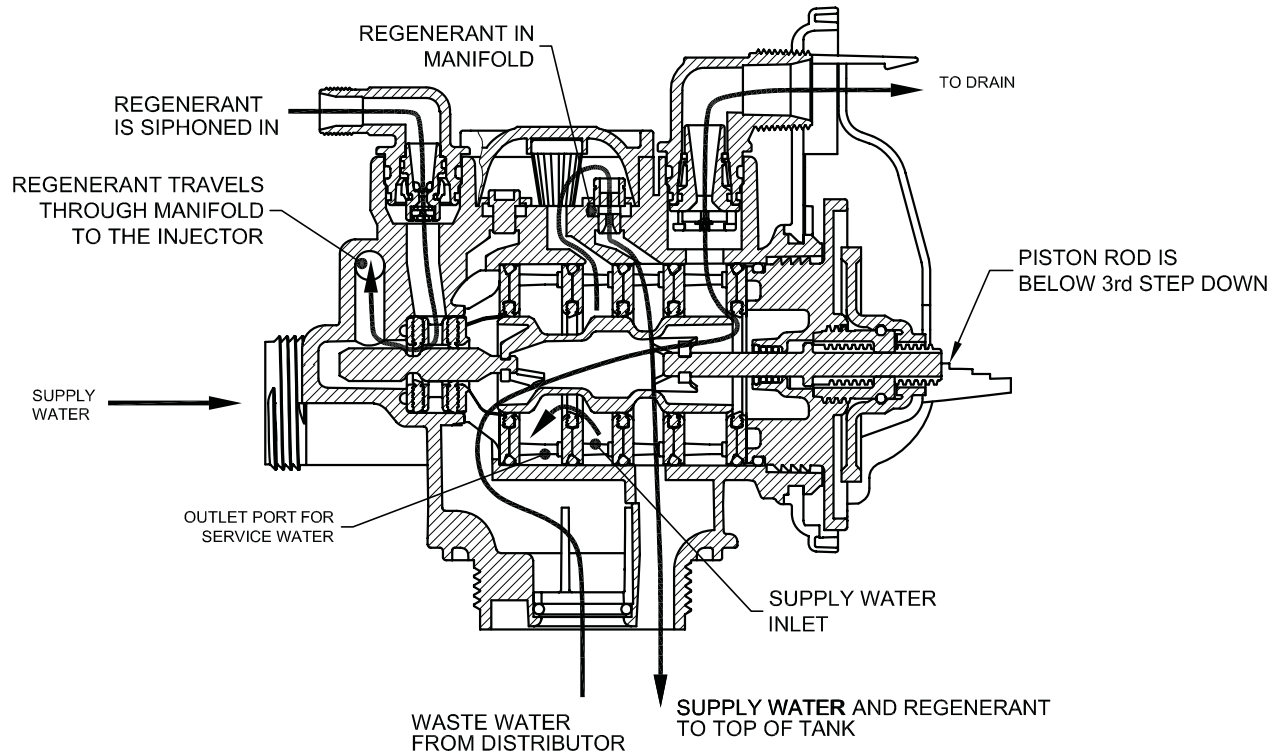

(WS1ER Only)

flow diagram...upflow brine

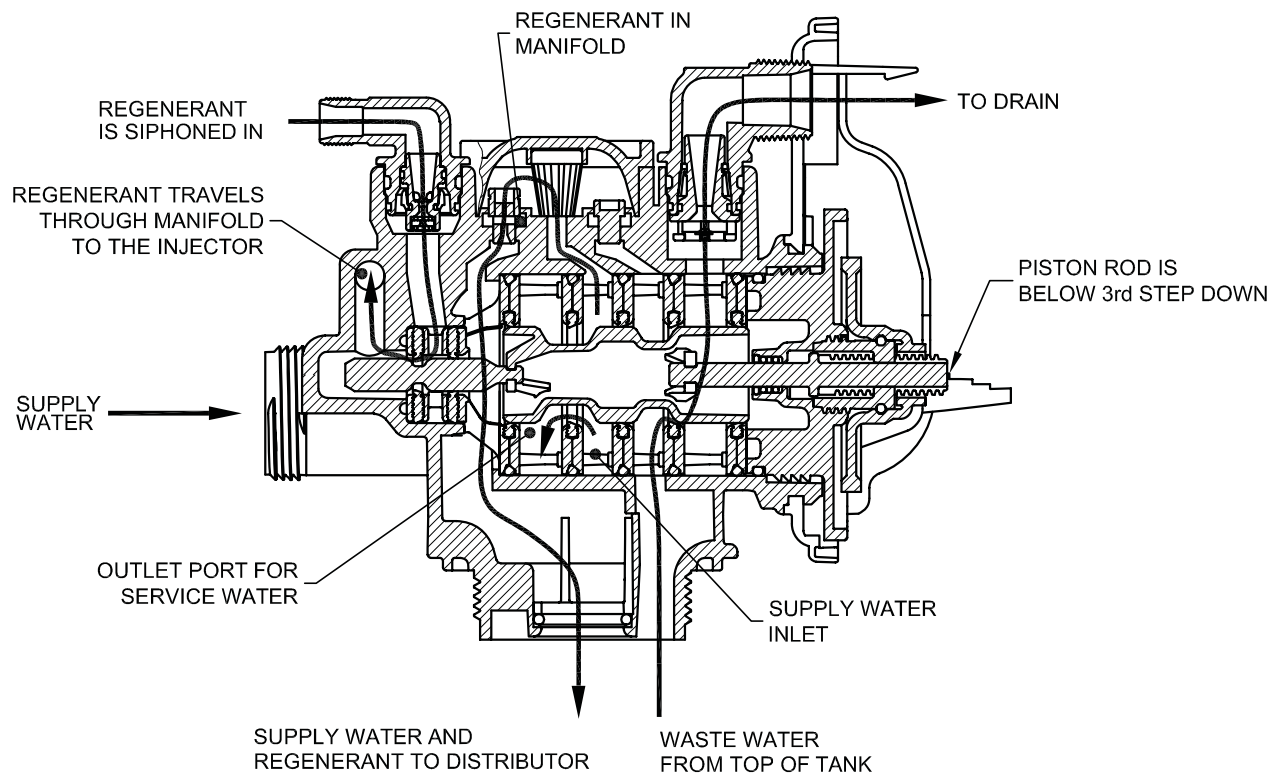

Flow Diagrams – Rinse and Fill

flow diagram...rinse

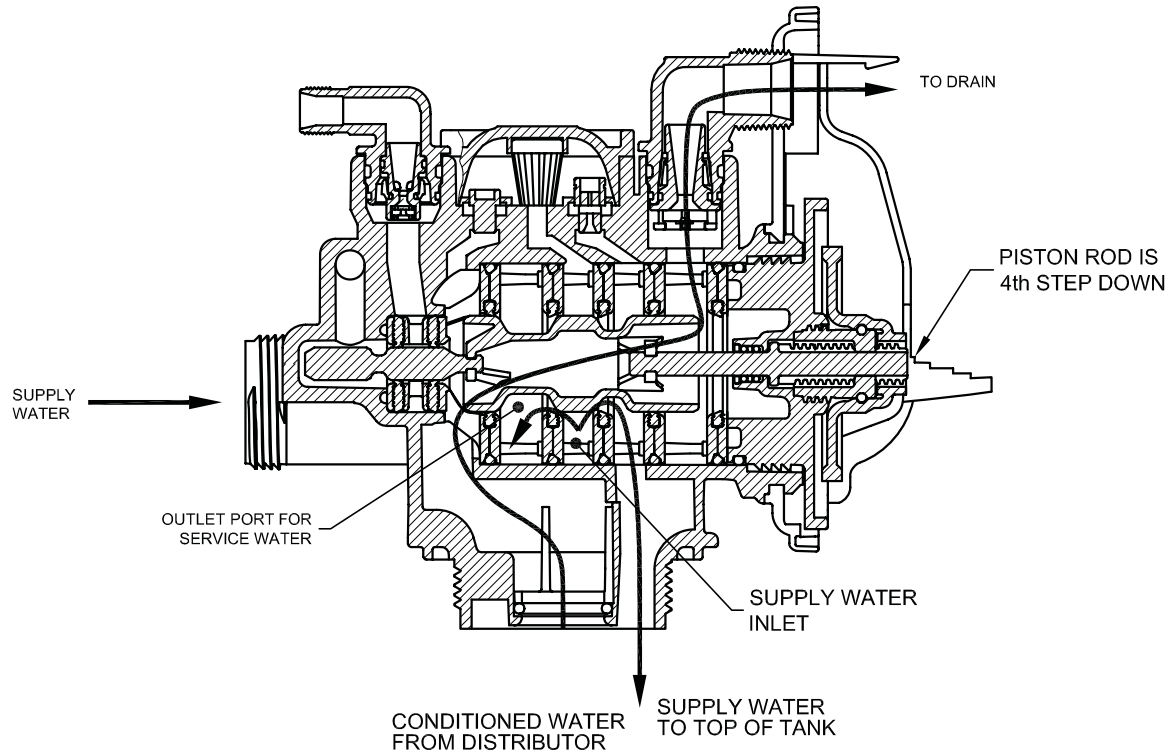

flow diagram...fill

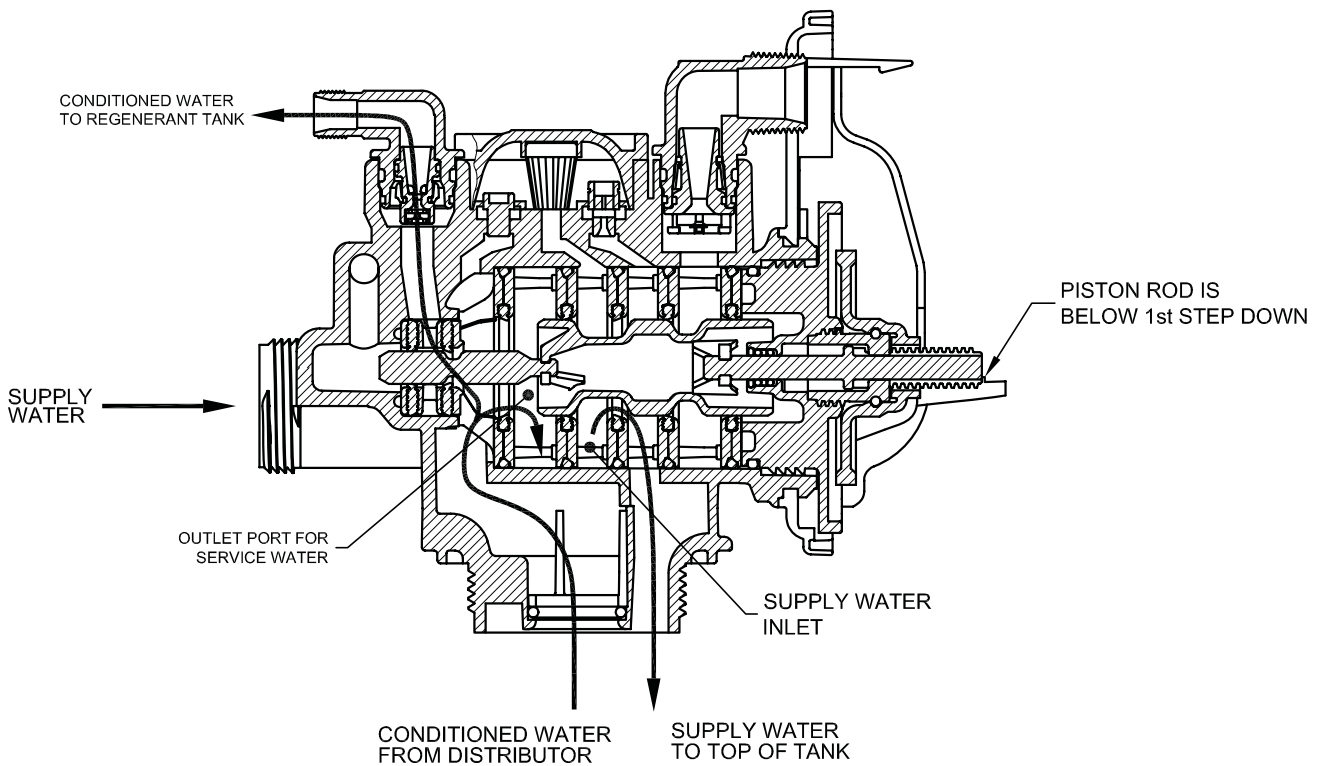

WS1 Wrench (Order No. V3193-01)

Although no tools are necessary to assemble or disassemble the valve, the WS1 wrench (shown in various positions on the valve) may be purchased to aid in assembly or disassembly.

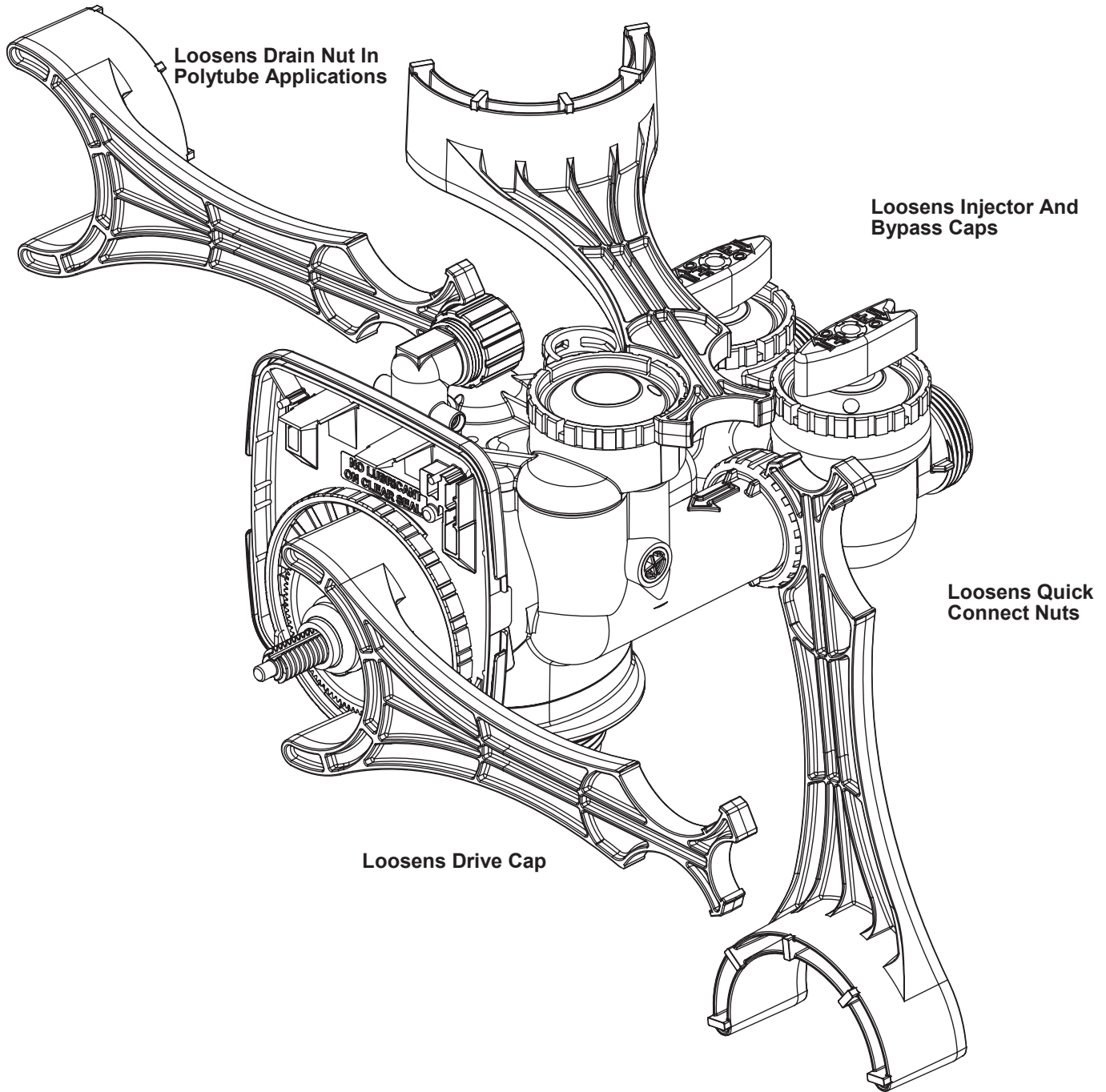

Service Instructions

Drive Assembly

Remove the valve cover to access the drive assembly.

Disconnect the power source plug (black wire) from the PC board prior to disconnecting the motor or water meter plugs from the PC board. The power source plug connects to the four-pin jack. The motor plug connects to the two-pin jack on the left-hand side of the PC board. The water meter plug (gray wire) connects to the three-pin jack on the far right-hand side of the PC board.

The PC board can be removed separately from the drive bracket but it is not recommended. Do not attempt to remove the display panel from the PC board. Handle the board by the edges. To remove the PC board from the drive bracket, unplug the power, water meter and motor plugs from the PC board. Lift the middle latch along the top of the drive bracket while pulling outward on the top of the PC board. The drive bracket has two plastic pins that fit into the holes on the lower edge of the PC board. Once the PC board is tilted about 45° from the drive bracket it can be lifted off of these pins. To reinstall the PC board, position the lower edge of the PC board so that the holes in the PC board line up with the plastic pins. Push the top of the PC board towards the valve until it snaps under the middle latch, weave the power and water meter wires into the holders and reconnect the motor, water meter and power plugs.

The drive bracket must be removed to access the drive cap assembly and pistons or the drive gear cover. It is not necessary to remove the PC board from the drive bracket to remove the drive bracket. To remove the drive bracket start by removing the plugs for the power source and the water meter. Unweave the wires from the side holders. Two tabs on the top of the drive back plate hold the drive bracket in place. Simultaneously lift the two tabs and gently ease the top of the drive bracket forward. The lower edge of the drive bracket has two notches that rest on the drive back plate. Lift up and outward on the drive bracket to disengage the notches.

To reassemble, seat the bottom of the drive bracket so the notches are engaged at the bottom of the drive back plate. Push the top of the drive bracket toward the two latches. The drive bracket may have to be lifted slightly to let the threaded piston rod pass through the hole in the drive bracket. Maintain a slight engaging force on top of the drive bracket while deflecting the bracket slightly to the left by pressing on the side of the upper right corner. This helps the drive gears mesh with the drive cap assembly. The drive bracket is properly seated when it snaps under the latches on the drive back plate. If resistance is felt before latching, then notches are not fully engaged, the piston rod is not in hole, the wires are jammed between the drive bracket and drive back plate, or the gear is not engaging the drive cap assembly.

To inspect the drive gears, the drive gear cover needs to be removed. Before trying to remove the gear cover, the drive bracket must be removed from the drive back plate. (Refer to the instructions above regarding removing the drive bracket from the drive back plate. The drive gear cover can be removed from the drive bracket without removing the motor or the PC board.) The drive gear cover is held in place on the drive bracket by three clips. The largest of the three clips is always orientated to the bottom of the drive bracket. With the PC board facing up, push in and down on the large clip on the drive gear cover. Handle the cover and the gears carefully so that the gears do not fall off the pegs in the cover.

Replace broken or damaged drive gears. Do not lubricate any of the gears. Avoid getting any foreign matter on the reflective coating because dirt or oils may interfere with pulse counting.

The drive gear cover only fits on one way, with the large clip orientated towards the bottom. If all three clips are outside of the gear shroud on the drive bracket the drive gear cover slips easily into place.

The drive bracket does not need to be removed from the drive plate if the motor needs to be removed. To remove the motor, disconnect the power and motor plugs from the jacks on the PC board. Move the spring clip loop to the right and hold. Rotate the motor at least a ¼ turn in either direction so the wires are vertical (up & down) before gently pulling on the wire connectors to remove the motor. Pulling directly on the wires without rotating the motor may break the wires off the motor.

Replace the motor if necessary. Do not lubricate the motor or the gears. To reinstall the motor, move the spring clip loop to the right and hold. Gently turn the motor while inserting so that the gear on the motor meshes with the gears under the drive gear cover. Release the spring clip loop and continue to rotate the motor until the wires are horizontal and the motor housing engages the small plastic bulge inside the drive bracket motor retainer. Reconnect the motor plug to the two-pronged jack on the lower left side of the PC board. If the motor will not easily engage with the drive gears when reinstalling, lift and slightly rotate the motor before reinserting. Reconnect the power plug.

Replace the valve cover. After completing any valve maintenance, press and hold NEXT and REGEN buttons for 3 seconds or unplug power source jack (black wire) and plug back in. This resets the electronics and establishes the service piston position. The display should flash all wording, then flash the software version and then reset the valve to the service position.

Drive Cap Assembly, Main Piston and Regenerant Piston

The drive assembly must be removed to access the drive cap assembly. The drive cap assembly must be removed to access the piston(s). The drive cap assembly is threaded into the control valve body and seals with an o-ring. To remove the drive cap assembly use the special plastic wrench or insert a ¼" to ½" flat blade screwdriver into one of the slots around the top 2" of the drive cap assembly so it engages the notches molded into the drive back plate around the top 2" of the piston cavity. See Figure 5. The notches are visible through the holes. Lever the screwdriver so the drive cap assembly turns counter clockwise. Once loosened unscrew the drive cap assembly by hand and pull straight out.

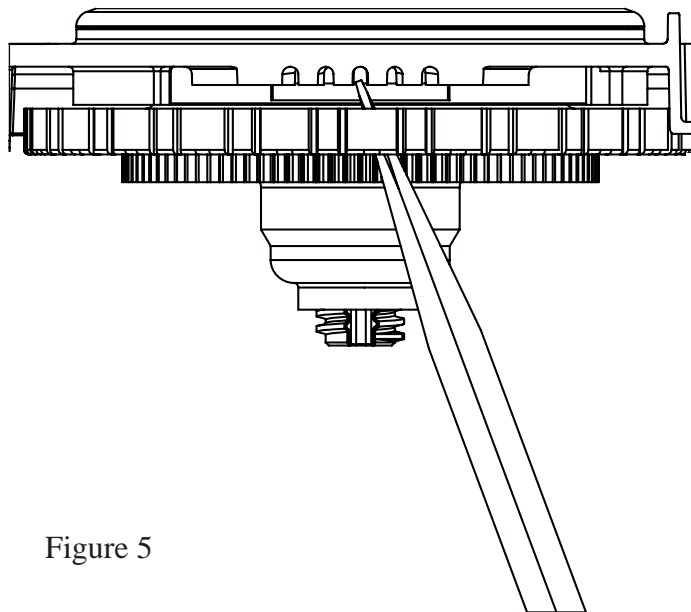

Figure 5

The drive cap assembly contains the drive cap, the main drive gear, drive cap spline, piston rod and various other parts that should not be disassembled in the field. The only replaceable part on the drive cap assembly is the o-ring. Attached to the drive cap assembly is the main piston (downflow or upflow) and if a regenerant is used, a regenerant piston.

The regenerant piston (the small diameter one behind the main piston) is removed from the main piston by pressing sideways and unsnapping it from its latch. Chemically clean in dilute sodium bisulfite or vinegar, or replace the regenerant piston if needed. To remove the main downflow or upflow piston fully extend the piston rod and then unsnap the main piston from its latch by pressing on the side with the number. Chemically clean in dilute sodium bisulfite or vinegar, or replace the main piston.

Reattach the main piston to the drive cap assembly. Reattach the regenerant piston (if needed) to the main piston. Do not lubricate the piston rod, main piston or regenerant piston. Lubricant will adversely affect the clear lip seals. Reinsert the drive cap assembly and piston into the spacer stack assembly and hand tighten the drive cap assembly. Continue to tighten the drive cap assembly using a screwdriver as a ratchet until the black o-ring on the spacer stack assembly is no longer visible through the drain port. Excessive force can break the notches molded into the drive back plate. Make certain that the main drive gear still turns freely. The exact position of the piston is not important as long as the main drive gear turns freely.

Reattach the drive assembly to the control valve and connect all plugs. After completing any valve maintenance, press and hold NEXT and REGEN buttons for 3 seconds or unplug power source jack (black wire) and plug back in. This resets the electronics and establishes the service piston position. The display should flash all wording, then flash the software version and then reset the valve to the service position.

Note: Refer to Figure 6 to identify main piston.

Spacer Stack Assembly

(Refer to Figure 6 for WS1ER & WS1.25ER spacer stack identification.)

To access the spacer stack assembly remove the drive assembly, drive cap assembly and piston. The spacer stack assembly can be removed easily without tools by using thumb and forefinger. Inspect the black o-rings and clear lip seals for wear or damage. Replace the entire stack if necessary. Do not disassemble the WS1ER or WS1.25ER stack.

The spacer stack assembly may be chemically cleaned (dilute sodium bisulfite or vinegar) or wiped with a soft cloth.

The spacer stack assembly can be pushed in to the control valve body bore by hand. Since the spacer stack assembly can be compressed it is easier to use a blunt object (5/8" to 1-1/8" in diameter) to push the center of the assembly into the control valve body. The assembly is properly seated when at least four threads are exposed (approximately 5/8"). Do not force the spacer stack assembly in. The control valve body bore interior can be lubricated with silicone to allow for easy insertion of the entire stack. Do not use silicone or any other type of lubricant on the clear lip seals or the piston.

Reattach the drive cap assembly and piston(s) and the drive assembly.

After completing any valve maintenance, press and hold NEXT and REGEN buttons for 3 seconds or unplug power source jack (black wire) and plug back in. This resets the electronics and establishes the service piston position. The display should flash all wording, then flash the software version and then reset the valve to the service position.

Injector Cap, Screen, Injector Plug and Injector

Unscrew the injector cap and lift off. Loosen cap with special plastic wrench or pliers if necessary. Attached to the injector cap is a screen. Remove the screen and clean if fouled.

The plug and/or injector can be pried out with a small screwdriver. The plug can be wiped clean. If the plug leaks replace the entire plug. The injector consists of a throat and a nozzle. Chemically clean the injector with vinegar or sodium bisulfite. The holes can be blown out with air. Both pieces have small diameter holes that control the flow rates of water to insure that the proper concentration of regenerant is used. Sharp objects, which can score the plastic, should not be used to clean the injector. Scoring the injector or increasing the diameter of the hole could change the operating parameters of the injector.

Two holes are labeled DN and UP. Check for compliance. See Table.

Compliance Table

Application	Injector and/or Plug(s)	Main Piston	Regenerant Piston	Stack	Body
WS1ER Downflow Softener	Injector in “DN” hole, Plug in “UP” hole	V3011	V3174	V3005	V3001 or V3001-02 (Mixing)
WS1ER Backwash Only Filter	Plug in “DN” and “UP” holes, Install Refill Port Plug	V3011	None	V3005	V3001 or V3001-02 (Mixing)
WS1ER Upflow Softener	Injector in “UP” hole, Plug in unlabeled hole	V3011-01	V3174	V3005	V3001UP or V3001-02UP (Mixing)
WS1.25ER Downflow Softener (1.32" Distributor)	Injector in “DN” hole, Plug in “UP” hole	V3407	V3174	V3430	V3020 or V3020-01 (Mixing)
WS1.25ER Backwash Only Filter (1.32" Distributor)	Plug in “DN” and “UP” holes, Install Refill Port Plug	V3407	None	V3430	V3020 or V3020-01 (Mixing)
WS1.25ER Downflow Softener (32mm Distributor)	Injector in “DN” hole, Plug in “UP” hole	V3407	V3174	V3430	V3020-02 or V3020-03 (Mixing)
WS1.25ER Backwash Only Filter (32mm Distributor)	Plug in “DN” and “UP” holes, Install Refill Port Plug	V3407	None	V3430	V3020-02 or V3020-03 (Mixing)

Push the plug(s) and/or injectors firmly in place, replace the screen and hand tighten the injector cap.

Refill Flow Control Assembly or Refill Port Plug

To clean or replace the refill flow control, pull out the elbow-locking clip and then pull straight up on the elbow. Replace the elbow locking clip in the slot so that it is not misplaced. Twist to remove the white flow control retainer. The flow control can be removed by prying upward through the side slots of the retainer with a small flat blade screwdriver.

Chemically clean the flow control or the white flow control retainer using dilute sodium bisulfite or vinegar. Do not use a wire brush. If necessary, replace the flow control, o-ring on the flow control retainer, or the o-ring on the elbow.

Reseat the flow control so the rounded end is visible in the flow control. Reseat the white flow control retainer by pushing the retainer into the elbow until the o-ring seats. Remove locking clip, push down on elbow to reseat and insert locking clip.

Do not use Vaseline, oils, or other unacceptable lubricants on o-rings. A silicone lubricant may be used on the o-ring on the elbow or the white retainer.

Water Meter or Meter Plug

The water meter assembly is connected to the PC board by a wire. If the entire water meter assembly is to be replaced, remove the control valve cover and disconnect the power source and water meter plugs from the PC board. Unlatch the drive assembly and lean it forward. Unthread the water meter wire from the side of the drive assembly and through the drive back plate. To reinstall, rethread the water meter wire through the drive back plate and the side of the drive assembly. Reattach the drive assembly and the water meter and power plugs.

THIS WATER METER SHOULD NOT BE USED AS THE PRIMARY MONITORING DEVICE FOR CRITICAL HEALTH EFFECT APPLICATIONS.

If no water meter wire is visible, then a plug is installed, not a water meter.

The water meter wire does not need to be removed from the PC board if the water meter is only being inspected and cleaned. To remove the water meter assembly, unscrew the meter cap on the left side of the control valve. Pliers may be used to unscrew the nut if necessary.

With the nut removed, a slot at the top of the water meter is visible. Twist a flat blade screwdriver in the slot between the control valve body and the meter. When the meter is part way out it is easy to remove the water meter from the housing. Once the water meter is removed from the control valve body, gently pull forward on the turbine to remove it from the shaft.

Do not use a wire brush to clean the turbine. Wipe with a clean cloth or chemically clean in dilute sodium bisulfite or vinegar. The turbine can be immersed in the chemical. Do not immerse electronics. If the turbine is scored or damaged or the bearings on the turbine are worn, replace the turbine.

Do not lubricate the turbine shaft. The turbine shaft bearings are prelubricated. Do not use Vaseline, oils, or other unacceptable lubricants on the o-ring. A silicone lubricant may be used on the black o-ring.

Snap the turbine on the shaft and reinsert the water meter into the side slot. Hand tighten the nut. Do not use a pipe wrench to tighten nut.

Mixing Valve

To clean or replace the mixing valve, unthread the mixing valve from the valve body. Chemically clean the mixing valve with a dilute sodium bisulfite or vinegar solution. Do not use Vaseline, oils, or other unacceptable lubricants on o-rings. A silicone lubricant may be used on the o-ring. Before replacing the mixing valve in the valve body turn the knob clockwise so that the mixing valve is in the open position. Failure to do this may cause damage to the mixing valve when it is screwed in to the valve body.

To adjust the blended water, close the mixing valve. Open a water faucet to the desired flow rate. Open the mixing valve until the desired hardness is reached. Close the faucet.

Bypass Valve

The working parts of the bypass valve are the rotor assemblies that are contained under the bypass valve caps. Before working on the rotors, make sure the system is depressurized. Turn the red arrow shaped handles towards the center of the bypass valve and back several times to ensure rotor is turning freely.

The nuts and caps are designed to be unscrewed or tightened by hand. If necessary a pliers can be used to unscrew the nut or cap. Do not use a pipe wrench to tighten or loosen nuts or caps. Do not place screwdriver in slots on caps and/or tap with a hammer. To access the rotor, unscrew the cap and lift the cap, rotor and handle out as one unit. Twisting the unit as you pull it out will help to remove it more easily. There are three o-rings: one under the rotor cap, one on the rotor stem and the rotor seal. Replace worn o-rings. Clean rotor. Reinstall rotor.

When reinstalling the red arrow handles be sure that:

1. The handle pointers are lined up with the control valve body arrows, and the rotor seal o-ring and retainer on both rotors face to the right when being viewed from the front of the control valve; or
2. Arrows point toward each other in the bypass position.

Since the handles can be pulled off, they could be accidentally reinstalled 180° from their correct orientation. To install the red arrow handles correctly, keep the handles pointed in the same direction as the arrows engraved on the control valve body while tightening the bypass valve caps.

After completing any valve maintenance, press and hold NEXT and REGEN buttons for 3 seconds or unplug power source jack (black wire) and plug back in. This resets the electronics and establishes the service piston position. The display should flash all wording, then flash the software version and then reset the valve to the service position.

Table 10
Troubleshooting Procedures

Problem	Possible Cause	Solution
1. Timer does not display time of day	a. AC Adapter unplugged	a. Connect power
	b. No electric power at outlet	b. Repair outlet or use working outlet
	c. Defective AC Adapter	c. Replace AC Adapter
	d. Defective PC board	d. Replace PC board
2. Timer does not display correct time of day	a. Switched outlet	a. Use uninterrupted outlet
	b. Power outage	b. Reset time of day and replace battery
	c. Defective PC board	c. Replace PC board
3. No softening/filtering display when water is flowing	a. Bypass valve in bypass position	a. Put bypass valve in service position
	b. Meter connection disconnected	b. Connect meter to PC board
	c. Restricted/stalled meter turbine	c. Remove meter and check for rotation or foreign material
	d. Defective meter	d. Replace meter
	e. Defective PC board	e. Replace PC board
4. Control valve regenerates at wrong time of day	a. Power outages	a. Reset control valve to correct time of day and replace battery
	b. Time of day not set correctly	b. Reset to correct time of day
	c. Time of regeneration incorrect	c. Reset regeneration time
	d. Control valve set at "on 0" (immediate regeneration)	d. Check control valve set-up procedure regeneration time option
	e. Control valve set at NORMAL + on 0	e. Check control valve set-up procedure regeneration time option
5. ERROR followed by code number Error Code 1001 -Unable to recognize start of regeneration Error Code 1002 – Unexpected stall Error Code 1003 – Motor ran to long, timed out trying to reach next cycle position Error Code 1004 - Motor ran to long, timed out trying to reach home position If other Error Codes followed by a number display contact the factory.	a. Control valve has just been serviced	a. Press NEXT and REGEN for 3 seconds or unplug power source jack (black wire) and plug back in to reset control valve
	b. Foreign matter is lodged in control valve	b. Check piston and spacer stack assembly for foreign matter
	c. High drive forces on piston	c. Replace piston(s) and spacer stack assembly
	d. Control valve piston not in home position	d. Press NEXT and REGEN for 3 seconds or unplug power source jack (black wire) and plug back in to reset control valve
	e. Motor not inserted fully to engage pinion, motor wires broken or disconnected, motor failure	e. Check motor and wiring. Replace motor if necessary
	f. Drive gear label dirty or damaged, missing or broken gear	f. Replace or clean drive gear
	g. Drive bracket incorrectly aligned to back plate	g. Reseat drive bracket properly
	h. PC board is damaged or defective	h. Replace PC board
	i. PC board incorrectly aligned to drive bracket	i. Ensure PC board is correctly snapped on to drive bracket

Problem	Possible Cause	Solution
6. ERROR followed by LoFlo	a. Water is flowing at a flow rate of less than 1 gpm for more than 3 hours.	a. Check toilets (water closets), faucets, etc., for a leak.
7. Control valve stalled in regeneration	a. Motor not operating	a. Replace motor
	b. No electric power at outlet	b. Repair outlet or use working outlet
	c. Defective AC Adapter	c. Replace AC Adapter
	d. Defective PC board	d. Replace PC board
	e. Broken drive gear or drive cap assembly	e. Replace drive gear or drive cap assembly
	f. Broken piston retainer	f. Replace drive cap assembly
	g. Broken main or regenerant piston	g. Replace main or regenerant piston
8. Control valve does not regenerate automatically when REGEN button is depressed and held	a. AC Adapter unplugged	a. Connect AC Adapter
	b. No electric power at outlet	b. Repair outlet or use working outlet
	c. Broken drive gear or drive cap assembly	c. Replace drive gear or drive cap assembly
	d. Defective PC board	d. Replace PC board
9. Control valve does not regenerate automatically but does when REGEN button is depressed	a. By-pass valve in bypass position	a. Put bypass valve in normal operation position
	b. Meter connection disconnected	b. Connect meter to PC board
	c. Restricted/stalled meter turbine	c. Remove meter and check for rotation or foreign matter
	d. Defective meter	d. Replace meter
	e. Defective PC board	e. Replace PC board
	f. Set-up error	f. Check control valve set-up procedure
10. Time of day flashes on and off	a. Power outage	a. Reset the time of day and replace battery

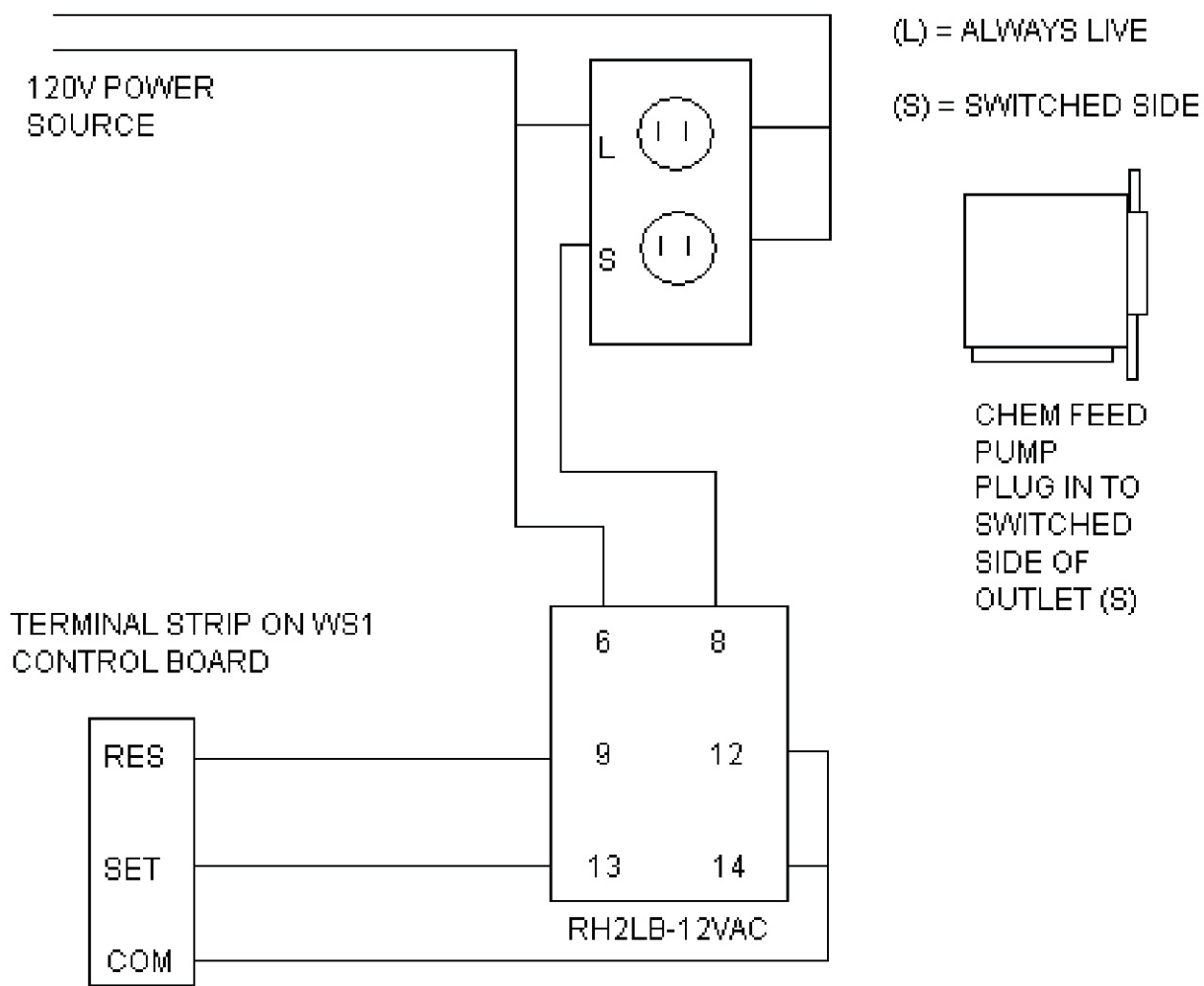

WIRING SCHEMATIC FOR WS1 PREMIER CHEMICAL FEED FLOW SWITCH RELAY

