

## ProLine® XE POWER VENT

### ENERGY SAVINGS

- Industry-leading energy efficient power vent, with up to a 0.70 EF
- ENERGY STAR® qualified models (except 60 and 75 gallon models)
- 2" CFC-free foam insulation to improve energy efficiency
- Built-in heat traps on the water inlet and outlet reduce the amount of heat lost through piping
- Exceeds NRCan energy efficiency standards

### DESIGNED FOR PERFORMANCE

- ProLine® XE models are residential water heaters with commercial-grade quality
- Convenient 3/4" side taps for combination applications on 50 USG high-input and 75 USG models
- Suitable for elevations up to 10,100 ft. (3,078 m)
- Available for both natural gas or propane
- Blue Diamond® glass coating protects steel tank from corrosion and maximizes tank life

### SAFETY FEATURES

- Sensor detects the presence of flammable vapours and automatically disables the unit, preventing their ignition
- Robust air intake snorkel inhibits flammable vapours from entering the combustion chamber

### SERVICEABILITY

- State-of-the-art electronic gas control features advanced self-diagnostic capability that makes troubleshooting easy
- Conveniently located T&P and drain valve for ease of installation and serviceability

### THE ULTIMATE IN VENTING FLEXIBILITY

- Can be vented with 2", 3" or 4" ULC S636 PVC, CPVC or polypropylene pipe
- Vertical or horizontal venting configurations

### WARRANTY

- 6 year limited tank and parts warranty
- 8 year limited tank and parts warranty models also available
- 2 and 4 year tank warranty extension kits are available for 6 year models

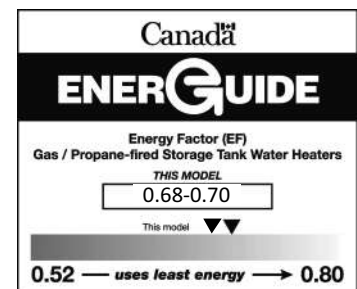

### PERFORMANCE

MODEL	SERIES	CAPACITY	INPUT	MAXIMUM CERTIFIED ALTITUDE	RECOVERY RATE AT 90°F TEMPERATURE RISE	FIRST HOUR RATING	ENERGY FACTOR	WARRANTY TANK/PARTS
		USG (L)	BTU/h	FT (M)	GPH (LPH)	GPH (LPH)		YEARS
<b>NATURAL GAS</b>								
GPVL 40	200/201	40 (151)	40,000	10,100 (3,078)	44 (167)	73 (276)	0.70	6/6
GPVT 40	200/201	40 (151)	50,000	10,100 (3,078)	50 (189)	90 (341)	0.70	6/6
GPVL 50	200/201	50 (189)	40,000	10,100 (3,078)	44 (167)	90 (341)	0.70	6/6
GPVT 50	200/201	50 (189)	50,000	10,100 (3,078)	50 (189)	96 (363)	0.70	6/6
GPVX 50L*	200/201	50 (189)	62,000	10,100 (3,078)	69 (261)	110 (416)	0.70	6/6
GPVL 60	200/201	60 (227)	42,000	10,100 (3,078)	46 (174)	106 (401)	0.70	6/6
GPVX 75L*	200/201	75 (284)	72,000	10,100 (3,078)	80 (303)	155 (587)	0.68	6/6
<b>NATURAL GAS</b>								
HPVL 50	200/201	50 (189)	40,000	10,100 (3,078)	44 (167)	90 (341)	0.70	8/8
HPVX 50L*	200/201	50 (189)	62,000	10,100 (3,078)	69 (261)	110 (416)	0.70	8/8

Natural gas models are series 200. Propane models are series 201.  
All models comply with national energy efficiency regulations.  
\* Model has side connections

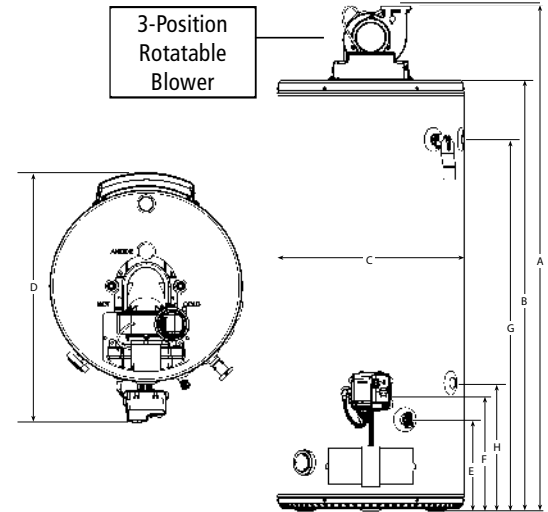

### DIMENSIONS & SHIPPING WEIGHT

MODEL	INSTALLATION HEIGHT	HEIGHT TO TOP OF TANK	TANK DIAMETER	OVERALL DEPTH	HEIGHT TO DRAIN VALVE	HEIGHT TO GAS INLET	HEIGHT TO T&P	HEIGHT TO UPPER SIDE CONNECTION	HEIGHT TO LOWER SIDE CONNECTION	SHIPPING WEIGHT
	A IN (CM)	B IN (CM)	C IN (CM)	D IN (CM)	E IN (CM)	F IN (CM)	G IN (CM)	G IN (CM)	H IN (CM)	LB (KG)
<b>NATURAL GAS</b>										
GPVL 40	59 (150)	49 5/8 (126)	22 (56)	29 1/8 (74)	11 (28)	13 1/4 (34)	42 1/2 (108)	N/A	N/A	174 (79)
GPVT 40	68 1/2 (174)	59 1/4 (150)	20 (51)	27 1/8 (69)	11 (28)	13 1/4 (34)	53 1/8 (135)	N/A	N/A	176 (80)
GPVL 50 / HPVL 50	60 1/8 (153)	50 3/4 (129)	24 (61)	31 1/8 (79)	11 (28)	13 1/4 (34)	43 3/4 (111)	N/A	N/A	198 (90)
GPVT 50	68 1/8 (173)	58 3/4 (149)	22 (56)	29 1/8 (74)	11 (28)	13 1/4 (34)	51 3/4 (131)	N/A	N/A	192 (87)
GPVX 50L / HPVX 50L	61 1/8 (155)	52 (132)	24 (61)	31 1/8 (79)	11 (28)	13 1/4 (34)	44 1/2 (113)	44 1/2 (113)	15 1/4 (39)	212 (96)
GPVL 60	67 1/4 (171)	57 7/8 (147)	24 (61)	31 1/8 (79)	11 (28)	13 1/4 (34)	50 3/8 (128)	N/A	N/A	216 (98)
GPVX 75L	70 5/8 (179)	61 1/4 (156)	26 (66)	33 1/8 (84)	11 (28)	13 1/4 (34)	53 (135)	53 (135)	15 1/4 (39)	277 (126)

### PREFERRED INSTALLATION

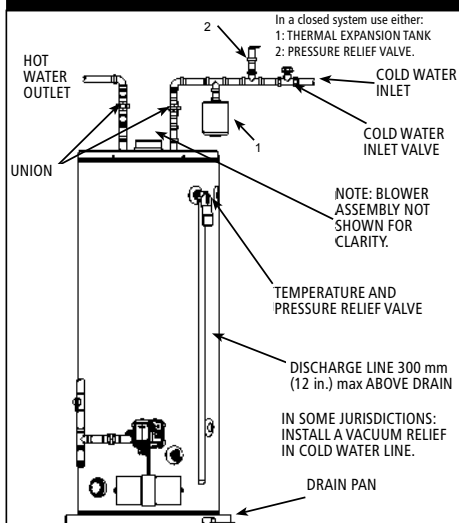

### VENT PIPE LENGTHS

MODEL	VENT PIPE DIAMETER IN	MINIMUM NUMBER OF ELBOWS REQUIRED*	MAXIMUM VENT LENGTH WITH ONE 90° ELBOW FT (M)	MINIMUM VENT LENGTH WITH ONE 90° ELBOW FT (M)
GPVL 40	2	0	50 (15.2)	7 (2.1)
GPVT 40	3	0	125 (38.1)	50 (15.2)
GPVL 50 / HPVL 50	4	0	180 (54.9)	125 (38.1)
GPVT 50	3	0	50 (15.2)	7 (2.1)
GPVL 60	4	0	125 (38.1)	50 (15.2)
GPVX 50L / HPVX 50L	3	0	50 (15.2)	7 (2.1)
GPVX 75L	4	0	125 (38.1)	50 (15.2)

\* Refer to installation manual for further details.

### VENT KITS

DESCRIPTION	PART NUMBER
3" Vent Kit Includes coupling for blower outlet and termination screens	100112701
4" Vent Termination Kit Includes termination screens	100112700