



THE CORSAIR

IPMS Phoenix / Craig Hewitt Chapter

Presidents Message

Hello everyone. I trust you've had a good start to the new year. My year has started out fine.

Everyone had an enjoyable time at the Awards Dinner on January 13th. I was extremely pleased with the venue. The dinner was a buffet, with tasty food, and we had plenty for everyone. The game we played, "Let's Make a Deal", was a lot of fun with many of us going home with great gifts.

I would like to remind everyone we are looking into changing the trophy packages for Modelzona this year. If you have any ideas, information, or just want to help, please contact Mike Pabis, Mike McFadden, or myself. We need to finalize this just after midyear.

I would also like to continue asking for demonstrations and/or presentations for the club meetings. We have February, March, and April filled (probably). I would like to have seven more for the remainder of the year.

There were three new people who attended the January meeting. I hope that we will see them all again soon.

That's all I have for this month. I'm going to take a look at the model I received for Christmas. I might start it soon, but I really should work on the three other models that are on my desk first.

Kevin

Corsair Stop Press Dates 2024

January	21st
February	25th
March	24th
April	21st
May	26th
June	23rd
July	21st
August	25th
September	22nd
October	27th
November	24th
December	22nd

THIS ISSUE

Secretaries Report.....	2
January Display Pictures.....	4
Club Awards Dinner.....	8
January Raffle Winners.....	11
1/32 Mustang (In Flight) L.Gorton.....	13
Club Contest Themes.....	20
Editors Corner.....	21
Where We Were.....	23
Club Meeting Calendar.....	32
Raffle Update.....	33
Upcoming Events.....	34
Website References	35

Secretaries Report

January 2, 2024, Meeting Minutes:

Kevin called to order at 7:01 pm

Visitor:

Logan Barainski (Arjan's Friend) subject 1/32 aircraft (F4-Phantom his favorite, her referred to as the beautiful flame brick.

Brent Barainski (Logan's father) – Current project is 1/72 U-boat.

Steve Bisel - Returning to the hobby after fort year, enter 9 models (from his shelf released in 1978), won best out of box at the 2023 Modelzona. Anything focused on aircraft WWI 1/32 and WWII & post WWII 1/48.

Officer Report

Treasurer (Bill) – Club is opening 2024 financially well. Final numbers for Modelzona are still being finalized but we did well. Couple annual expenses are coming, the rent for hall and storage unit. On the subject hall, Bill was informed by the management the building will still here for at least another 2 years.

Chapter (Scott) – Connected with Region 10 Coordinator Tony Humphry. Tony plans to start updating the regional website. Club's chapter has been renewed.

Membership Administrator (Lyn) – It new year, dues is due please see Bill and pay man so Lyn doesn't have to send out nasty gram email.

Member at Large (Hal) – Would like clubs on places where he can make presentation to promote the club and bring in new members.

Old Business:

Clubs award banquet in January 2024.

Discussion on changing Modelzona trophy package revisited. There is already a committee (Mike McFadden, Wendell Rogers, and Mike Pabis). Vendors and pricing are being put together by a couple of committee members not in attendance at the meeting.

Jeff Alderman suggest using the vendor the does the trophy for Desert Scale Classic. He asked to provide the pricing to the committee.

Some key points from discuss.

- Cost
- Pros and Cons
- Possible loss of profit from upgraded package. (Club current make money on every package)
- Possible increase to club dues
- Possible Increase to admission price for Modelzona

Secretaries Report

Contest Chair (Martin) – We have a new contest chair (Jerry Clark). The 2024 monthly contest has been created and will be posted in the Corsair. Martin did provide the 3 month contest subject.

Feb – US Armor (any scale) 1950 to Present, Mar – Non US aircraft from WWII, and Apr - Any US Coast Guard Vessel.

2023 modeler of year winner with 24 points Brian Baker

Other Business:

Seminars – Feb (Mike McFadden) and Mar (Brian Baker) are covered but more are needed. Mike M suggested put ideal or subject you might like to see on Facebook page. Steve “Grump” Collin, “Don’t be afraid because you don’t thing you are good speaker, remember you are amongst friends.”

Brian Baker had some information (for builds) on airplane modes that had complied from website and magazines he was offering to our members.

Old Business:

Club E-Board election.

- Since there were no write in or nomination from the floor Dick motioned the we accept ballot by acknowledgement. Several second and vote was unanimous.
- 2023 IPMS Phoenix-Craig Hewitt Chapter for Record.

•	President	Kevin Henthron
•	Vice President	Scott Reigel
•	Secretary	John Carroll
•	Treasurer	Bill Dunkle
•	Member at Large	Hal Sanguinetti
•	Membership Administrator	Lyn Gorton

New Business:

- Discussion about moving from Region 10 to Region 8
- Advantage’s location of club (closer), clubs from Region 8 comes to our events and we in turn attend most of their events.
- Mike M commented difficulties on get having a Regional convention.
- Dekker, Build and Bull at Hobby Bench at the Bell location every Saturday (the have 4 tables available).

January Display

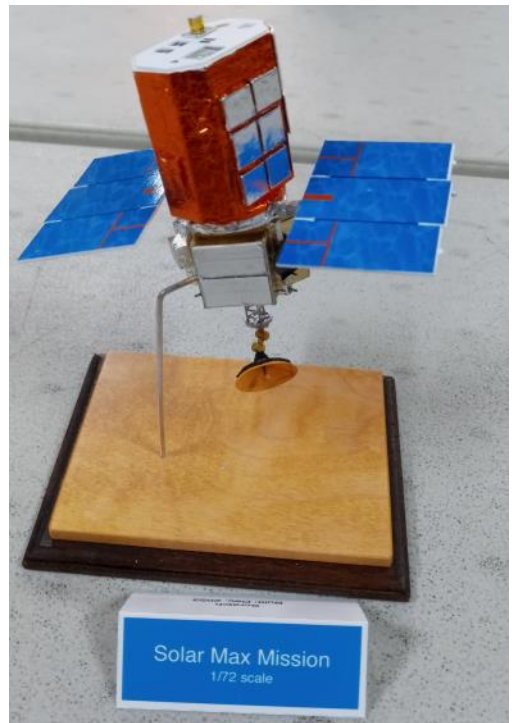

January Display



January Display



Fiat CR-32-Bis #147. Ex Austrian Air Force fighter taken over by Luftwaffe at the start of the war and used as a trainer.

January Display

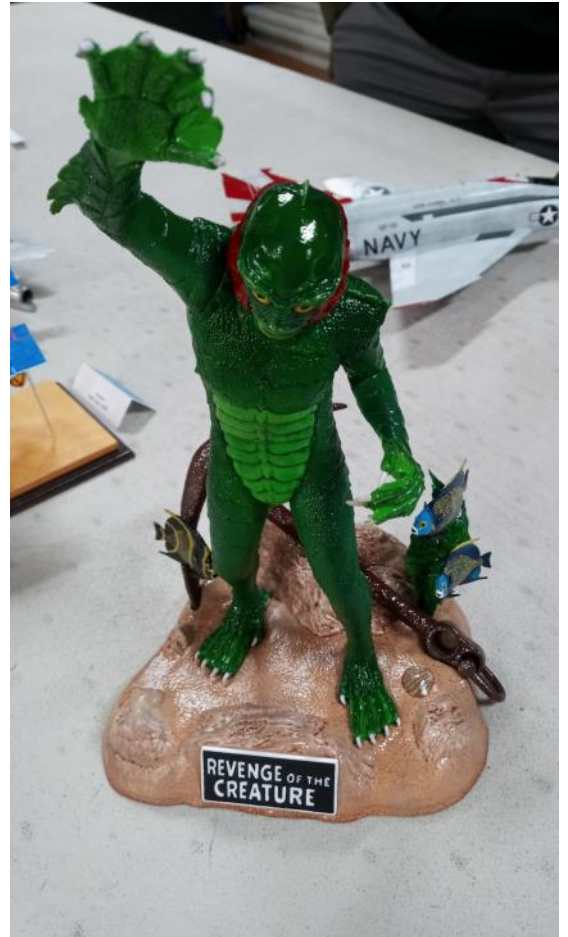

Awards Dinner

The 2023 Awards Dinner

The 2023 Awards Dinner was a great success. Any of the 36 members and spouses attending who arrived at Chompie's on January 13th expecting a bagel sandwich and chips were pleasantly surprised by the quantity and quality of food available on the buffet. In fact, one guest said it was even better than the food served at the recent Nationals in Texas. The dinner consisted of a choice of beef au jus or chicken piccata, four sides, salad and rolls topped off with a chocolate raspberry cake for dessert.



Other guests were pleased with the privacy of the room and the laid back, friendly atmosphere as well as the convenience of the cash bar. There was plenty of room to mingle and catch up with friends with a slide show prepared by Scott and Laurie playing in the background. In fact, the only negative comment heard all evening was the distance to the venue, which is always an issue.



Awards Dinner

Dick presented the Member(s) of the Year Awards to Kevin and myself, a total shock to both of us. The Modeler of the Year Award, going to Brian Baker, had been announced at the January club meeting and was not a shock due to his skill and number of contest entries.



Awards Dinner

For entertainment, Laura did a great job MCing the “Let’s Make A Deal” game, even dressing for the part. Many members went home with unexpected prizes. Dick added to the fun with an bonus raffle of his own. At the end of the night, the spouses each went home with a hand-made card and centerpiece.



All in all, the dinner was a success and we hope to see even more members attending the next awards dinner.

~Laurie Rice-Henthorn

January Raffle Winners



January Raffle Winners

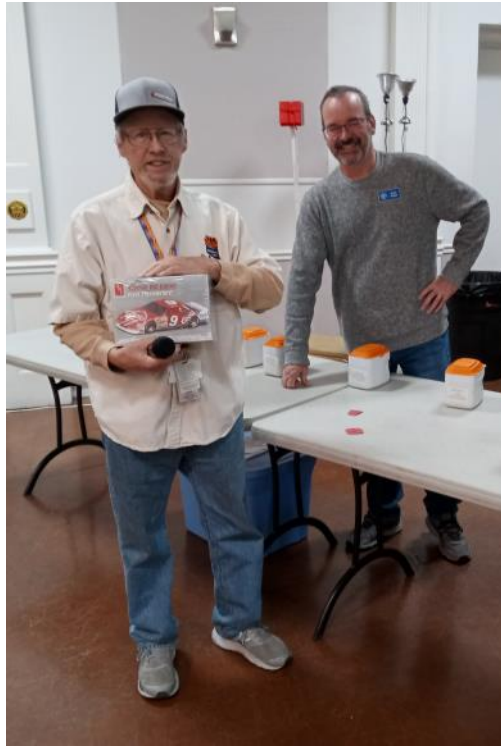

Revell 1/32 Mustang P-51D—5NA Lyn Gorton



I fully appreciate all of you who are regular contributors to this newsletter. I know most people look forward to reading about your various builds. I also know that I am constantly asking for more contributions. Last Christmas I was lucky enough to come home from the Christmas dinner with a 1/32 scale kit of a P51 Mustang. So just to prove that I also build I decided to write a review and add some technique notes.

I do not have enough room in my display cabinet for anything bigger than 1/48 and I detest aircraft that hang from the ceiling with props stopped with gear up. Jets of course do not have this problem but my preferred genre is 1/48 aircraft of WW2 so to deal with it I decided this model would be fitted with a prop blur propeller (Check out PropBlur.com)

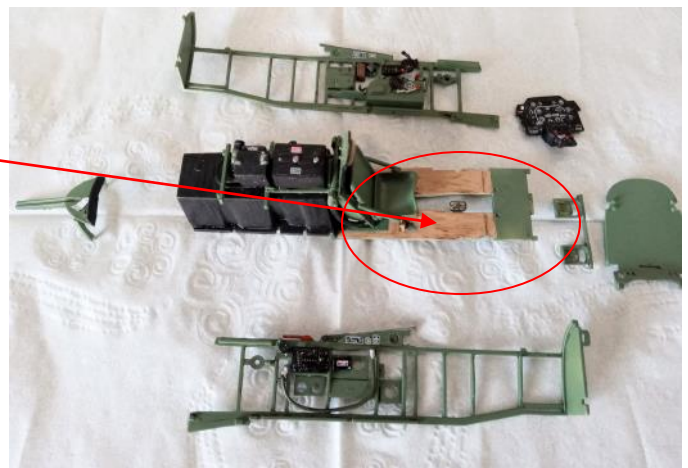

I believe that this kit is a new retool from Revell who look to be making a comeback much the same as Airfix did.

The kit has lots of detail but because it is going to be wheels up in-flight I started with the cockpit.

I usually start with the landing gear because that is usually the most fiddly bit.

There is a lot of detail in the cockpit and worth taking your time with. The floor was done by painting it with a light deck color and then dry brushing with a dark brown on a stiff brush to get a wood grain effect.

Revell 1/32 Mustang P-51D—5NA Lyn Gorton



The side walls and instrument panel went together well after painting with the interior green color. The Decal for the instrument panel settled well with microset.

I always put a layer of clear gloss on anything that requires a decal as it helps create a smooth surface for the decal to sit on and thus better adhesion.

The rest of the side wall instruments were applied after first painting them on the sprue, which I find is good for holding them in place—I usually scrape off any flash first and then spot touch up once the part is cut from the sprue and applied.

The component parts of the cockpit were then assembled with no problems—nice touch is the labeling on the batteries.

Revell 1/32 Mustang P-51D—5NA Lyn Gorton



Next up was the wing assembly and as I said previously this is a wheels up model so no undercarriage to do but if it were wheels down there is also some good detailing there including the cockpit floor which is painted zinc Chromate and the joystick fitted to it—the cockpit assembly fits over this



The fuselage sides are then fitted to the wings—no real problems there as it was a good fit. The only complaint is the usual with the wing roots needing to be filled and sanded to get rid of the gap. As you can see from the pictures the cockpit assembly fitted well and looks good with all the detail

Revell 1/32 Mustang P-51D—5NA Lyn Gorton

Next up was to fix the wing root gaps. I use this method whenever I have to sand and scrape near any surface detail. First I apply tamiya (or similar) masking tape either side of the gap to protect any surface detail. I then fill the hole and sand down the filler—this leaves a nice smooth joint with no damage to the surrounding surface



A similar treatment was given to other slight gaps such as fuselage seam and wheel well doors etc

Revell 1/32 Mustang P-51D—5NA Lyn Gorton

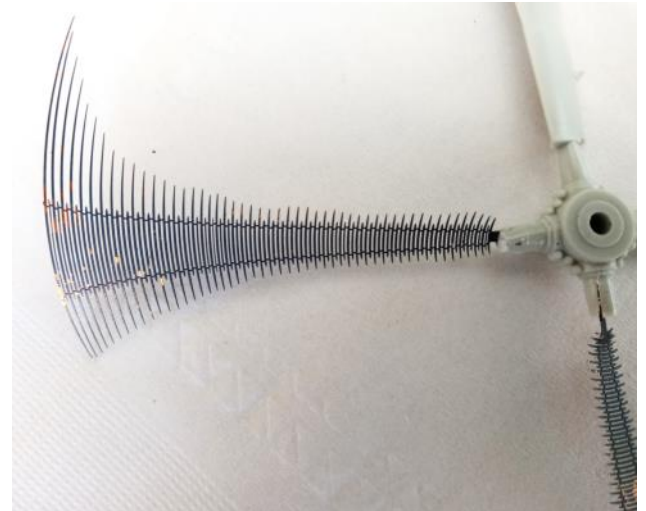

If you have not used Prop Blur before give it a go. I like the result I get and as far as I can see it is a viable alternative to having an actual rotating prop. I know some people use a fan to rotate the prop when taking photos or even installing an electric motor connected to the prop.

Both those methods are fine but for a model that is hanging from the ceiling it is not a viable fix

Prop blur props come in all sizes and you just need to order the amount you need. This model is a 4 bladed prop so each blade is an individual item. Smaller scales have 3 blades and even 2 blades as one item.

First off you need to fit your blades to the hub, I just used a razor saw and super glue. Make sure that you note the rotation of the prop blades before you remove them from the hub. Also make sure that you install them so the prop appears to be turning in the correct rotation direction.

The blades are PE so make sure they are clean and apply a very thin coat of a light gray undercoat. Do not use thick paint as it will clog the holes in the blades and ruin the effect.

Once it is dry apply a dark gray (not black) color starting from the hub ie the part of slowest rotation making sure you do not over do it—work towards the tip making the shade lighter as you go.

Do the same with a light yellow for the blade tips.



Revell 1/32 Mustang P-51D—5NA Lyn Gorton

A quick word about painting. I decided to do this as the Mustang flown by Colonel T.J.J. Christian. As you can see it is an unusual camo pattern with the bottom and some of the fuselage as Polished aluminum and a mixture of greens on the upper surfaces with a bright yellow nose. I always have done mustangs in the polished aluminum and for this I had enough Alclad polished aluminum to do this model.

I first applied a primer of Alclad gloss black as this gives a better base for the polished surface. Once that was dry (24 Hours) I applied the aluminum to the whole model and again left 24 hours to dry.

If you have never used Alclad before it is a good paint but very unforgiving if you do not let it dry. I also use gloves when handling after the paint is applied.

The camo patters and the Invasion Stripes on the underside and sides were masked off and appropriately painted.

I used an Olive matt and dark green for the Camo and the tailplane—this was the tricky part of the job masking out each color whilst making sure the aluminum remained intact and not over sprayed

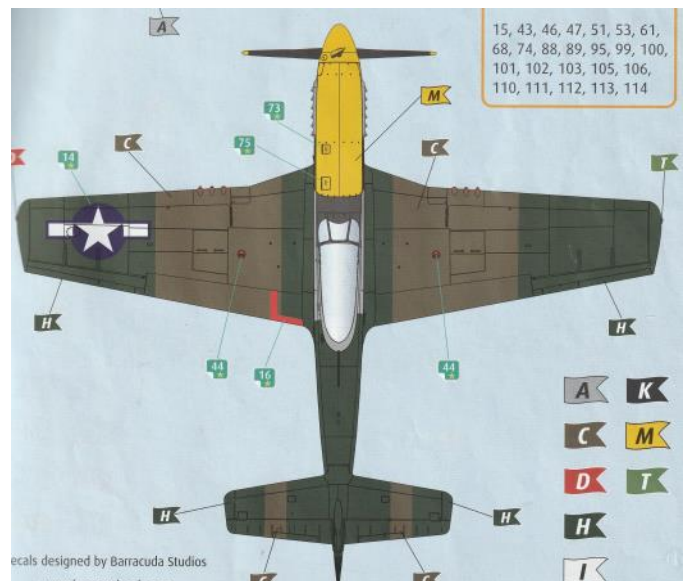
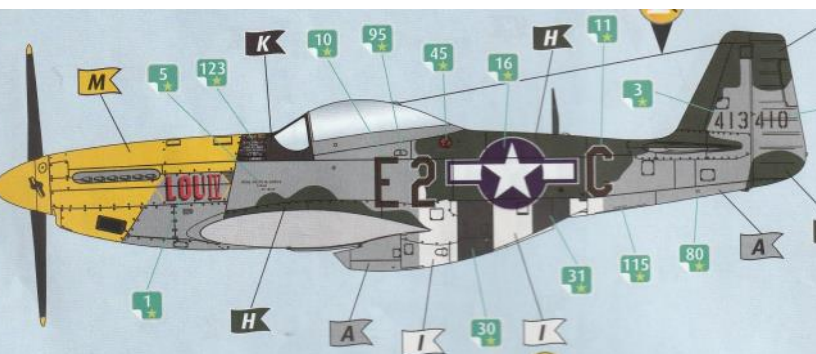
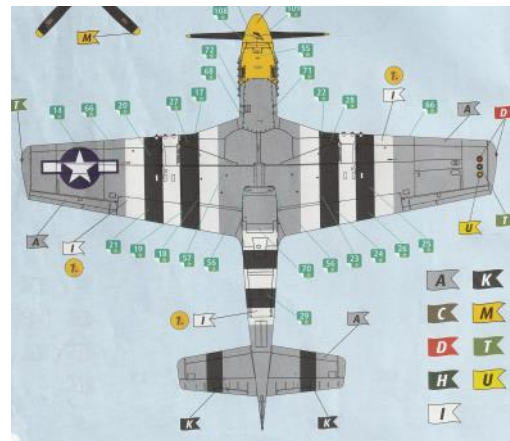

Revell 1/32 Mustang P-51D—5NA
Lyn Gorton



The finished work hung from the ceiling using a small cup hook and nylon (Fishing line) thread



2024 Club Contest Themes

JANUARY: No Contest

FEBRUARY: U.S. Armored vehicle; 1950 to present, any scale, alone or in a diorama.

MARCH: Any NON-U.S. aircraft used in WWII

APRIL: Any U.S. Coast Guard vessel of any year used in inland waters or open ocean.

MAY: Any artillery piece, ground or mounted (BUT NOT TANKS!) used in WWII or Korea from any country.

JUNE: Any NON-U.S. made automobile or truck produced AFTER 1950.

JULY: A Ship that has only primarily sails for movement. Can be an old Pirate ship !

AUGUST: Club Swap meet — NO CONTEST

SEPTEMBER: A totally 3-d printed figure, plane, vehicle or ship alone or as part of a diorama. Can be Sci-Fi or any genre.

OCTOBER: A helicopter from any country or time frame in any scale.

NOVEMBER: A 1/35 OR LARGER scale figure, bust or statue of a “famous” person. Can be a historical, scientist, musician, actor/actress, etc. Male or female that is easily recognizable by most people.

DECEMBER: NO CONTEST, Holiday White Elephant



EDITORS CORNER

BY LYN GORTON

Note the switch of the **December meeting to the 2nd Tuesday** of the month(10th) so we can get the big room for the white elephant and avoid a clash with the VFW Pearl harbor remembrance.

At the February Meeting Mike Mackowski will give a presentation building resin aircraft kits. Much of the content will apply to any genre of model. Resin kits are usually short-run kits made of different material than mass produced styrene kits. This results in some extra steps and occasion application of different tools and techniques. The cool thing about resin kits is that they are often the only way to build a model of an unusual subject short of scratchbuilding. The example Mike will use is the 1/72 scale XF-91 (kit from Planet Models) that he brought to the January meeting.

It is once again time to pay your annual club dues \$12 for single and \$15 for family

Only members of Good Standing will be eligible to receive any of the benefits associated with club membership. (See page 31)

The easiest way to pay is bring cash and pay Bill directly at the monthly meeting.

I understand that some of you will not be able to make meetings so Bill Dunkle will be only too glad to give you his postal address and cheque details if you want to mail in your subscription.

Bill's email address is BDUNKLE@msn.com



EDITORS CORNER

BY LYN GORTON

Important Message From Club Treasurer Bill Dunkle

Beginning on February 17th and continuing on the 3rd Saturday of each month, the Club will now have access to the small meeting room at the American Legion Post for the purpose of Build N Bull sessions. We will have access from 10am to 3pm and kitchen will be open for lunch purchases. This session will be open to all members and guests.

Note that this is coming to the Club at no additional expense as I have negotiated this into our annual deal with the Post.

Bill Dunkle

WHERE WE WERE

Dirty Plastic February 1973

NO. 22

FEB. 1973



dirty plastic

ARIZONA HISTORICAL MODELERS SOCIETY IPMS/PHOENIX
PIMA PAISANOS IPMS/TUCSON
2033 N. 11TH AVE. PHOENIX, ARIZONA 85007

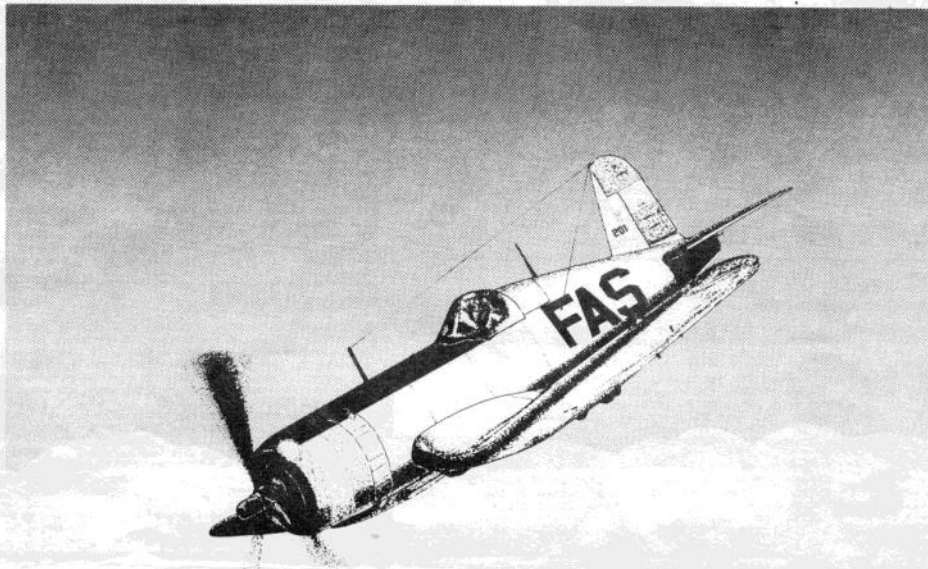

FG-1D

Fuerza Area Salvador

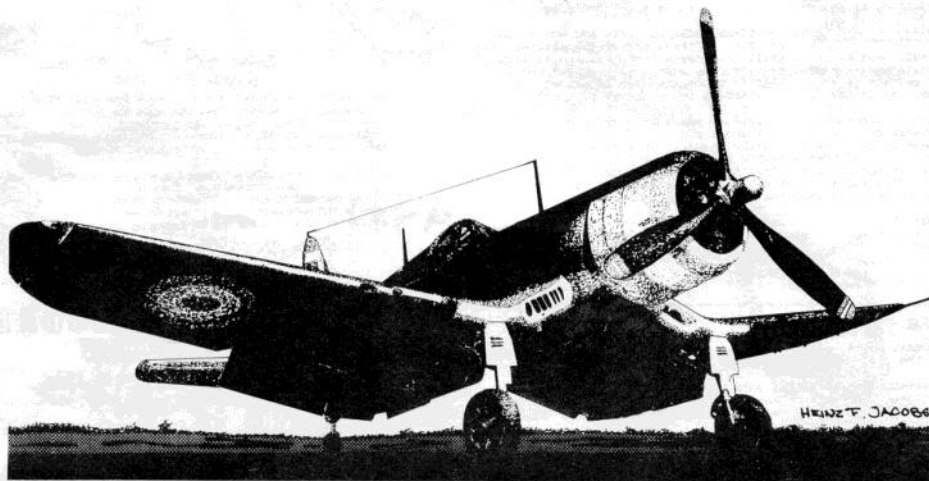

EDITOR - CHARLES K. KRAUSE JR.
TUCSON EDITOR - MICK ROTH

2033 NORTH 11th AVENUE PHOENIX, ARIZONA 85007
TYPING & PRINTING - MARGARET BEARD

COVER BY - HEINZ F. JACOBS

SUBSCRIPTIONS: \$ 3.00/YR.

WHERE WE WERE

Dirty Plastic February 1973

Dirty Plastic is a joint publication of the ARIZONA HISTORICAL MODELLERS SOCIETY, IPMS/Phoenix and PIMA PIASANOS, IPMS/Tucson. Subscriptions are \$3.00/year, 30¢ an issue. As this is issued for the benefit of Modellers it is not copyrighted, however, when reusing any article or drawing acknowledgement is appreciated.

-EVENTS-
IPMS Phoenix
 Social Wednesday, February 14, 7:30 PM
 DeVry Institute of Technology
 Highland & 24th Street
 Business Wednesday, February 28, 7:30 PM
 2033 No. 11th Avenue

IPMS Tucson
 P. O. Box 1363
 Tucson, 85702

Weekly: 7:30 PM every Friday
 Call Don Sproule (885-9549) for meeting location.

SOUTHERN CALIFORNIA SCALE MODEL SHOW

Saturday & Sunday, March 17 & 18. Griswold's Convention Center in Claremont, California. Inquiries can be addressed to Al Clemens, 4202 Ewart Street, Montclair, Ca., 91763 - (714) 983-2280.

THE 1973 IPMS/USA CONVENTION - Columbus, Ohio, July 20, 21, 22. Inquiries, Monte Nevhart, 1483 Dobson Sq., N., Columbus, Ohio 43229

THIS MONTH

San Salvadorian Goodyear FG-1D B. R. Baker

The beer commercial that says that you only get one chance in this life may usually be accurate, but the photographing of this Latin American FG-1D is an exception to that rule.

I first saw a group of about six Salvadorian FG-1D's during an escorted photographic tour through the now-defunct Naval Air Facility at Litchfield Park, Arizona, on April 9, 1958, but I was not permitted to make any photos, since they were on the flight line and were, incidentally, the property of a Foreign Government. So much for a rare bird -- or so I thought.

Later, on July 9, I had a chance to fly right side with my brother on a charter trip to Alpine, Texas, and when we landed at El Paso, I discovered a somewhat battered San Salvadorian FG-1D parked on the Municipal Airport ramp. Camera in hand, I descended like a cloud of locusts on the aircraft, photographing it, unfortunately only in black and white, from all angles, I was determined not to miss it again.

The aircraft had apparently been groundlooped on its delivery flight from Litchfield Park to El Salvador. Thanks to an abstinence of right (or was it left) rudder, D/P is able to publish these drawings, which were taken directly from my photographs. Perhaps a reader can fill us in on the subsequent service life of these aircraft.

BIOGRAPHY

Robert Forrest

I was born and raised in San Diego, California and graduated from San Diego State College in 1964. Since entering the Air Force I have been working in aircraft maintenance and have been stationed in New Mexico, Vietnam, Germany, California, Arizona, Iran, and now Ohio (Wright-Patterson). My experience has been with F-84's, F-100's, F-105's, F-4's, and A-7's. The overseas assignments presented some excellent opportunities to get information and photos, where possible, to put more accuracy into my model building.

I have always tended toward building model aircraft and was around 10 or 11 when I built my first kit. I think one of the earlier ones was a Revell B-36 which is still in storage somewhere in San Diego. My attention was attracted to 1/24 cars during high school and I built around 200 or those, most of which are also in storage in San Diego. My family has a few things to say about that!

I got back to aircraft during college and initially concentrated on 1/72 fighters only but now just about anything from the mid-30's to the present is fair game. I first heard about IPMS while stationed in Phoenix and have been a member since late 1970. Since my present assignment at the Air Force Institute of Technology takes up about 30 hours a day, the stack of unbuilt models keeps getting bigger. I hope to begin correcting that problem later this year.

By the way, Bob also mentioned having taken some airline slides while in Iran. If interested:

Capt. Robert Forrest
 8327 Philadelphia Dr.
 Fairborn, Ohio 45324

WANTED LIST

Heinz F. Jacobs

Needs photos, books, plans of German Railroad Engines & Rolling Stock of the 1940-45 period.

Also information on obtaining some 1/48 scale ("0" gauge) German Railroad Models of the same period. Who has a copy of Belona Railroad Gun Prints photos and/or drawings of Fieseler FI 156 "Storch" cockpit interiors?

NOTE:

In view of the rumor of the release of a 1/32 scale Me-163 Model, plans and detail drawings will appear in the May issue of D/P.

OPINION

Russ Sas

Wouldn't it be a nice thing if you could display your model without hearing about all its faults. I don't think I can remember ONE meeting where someone hasn't said something uncomplimentary about another's model.

Sure, that's a rash statement, but it's true! I've seen some of 'em, the members do some nice things with plastic, only to have some "BOZO" point out all the mistakes!

Now, it is one thing to offer modeling tips to someone who is less experienced than we are, this is helpful. But it's another thing to Nit-Pick, when someone is trying their best. Criticism like this has no place in our organization!! The sad thing is though, this sort of "criticism" is not limited to just models; some months back I was showing slides from "The Battle of Britain", and "Tora Tora" with the intent of providing entertainment for the members. Yet, all that was heard were statements like "that doesn't even look like a 109", or "that's the wrong model Spitfire, they didn't use them in that battle". Well Hell, who gives a damn?, I don't.

They were beautiful aerial photos, but nobody ever made any comments like that. We don't, (although I doubt it), come to the meetings to evaluate one another's modeling ability. None of us build on the same level, some put more work into their kits, while others don't. But I try to look at it this way: from the standpoint of the time and effort involved the individual put into the model.

But think ahead, what does this do to the new members that show up? Here comes a visitor, eager to show off his achievements, and some SOB shoots their ego to hell! It all boils down to this, if you can't say anything nice, then keep your mouth shut, maybe that's the best he can do! Could this be why our members are not showing up at the meetings?

HAWKER HUNTER T-7

Ray Sweet

Not long ago I vowed never to convert again, due in part to 6 months building a Privatier, and also to the vast variety now available from our friendly Hobby Shops. However on a recent trip to California I was inticed from this pledge by the new Air Conversions Company kit to convert the Airfix Hunter to the two seat trainer version. Price was a bit steep at \$1.75, however quality is very good. The parts are cast from a material which looks very much like soap, but glues, works and paints like plastic. The canopy is a good clear injection molding. Extra parts needed are the tail fairing, which I made from the top of a Bic pen, and the seats, which come from the spares file, originally from a jet prover I think. Follow the directions in the AC kit after assembling the body per Airfix, and you will have no trouble. This is the most trouble free conversion I have ever done, and I've done many. Airfix magazine has a good feature on this job on Page 382 of March '72 issue, complete with several color reference drawings.

However, odd ball that I am I choose to paint my model as WV 253 of the Empire Test Pilots' School, Farnborough. Profile center spread #167 gives good color side view. Top white, from canopy down spine and all of rudder and fin. Rest of aircraft red, including horizontal stab. Large white 24 aft of fus. root white WV 253 near tail, black chest line from nose to lower intake lip.

The T-7 is the real color bird of the Hawker Stable and there is no reason why any two models should be the same, as from all reference no two of the aircraft looked alike.

If you wish to do a further conversion on this bird you may model the Danish version, which did not have the notched wing. Carve off the extended leading edge - plug hole - shape, fill and sand.

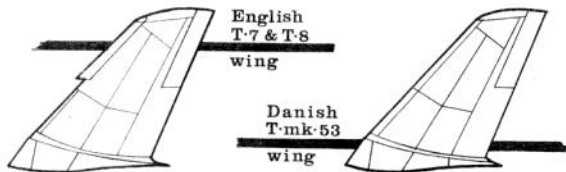

The wings on the Airfix Kit also benefit from a bit of sanding on the interior surface before assembly. This will thin the section and sharpen the trailing edge to a more scale shape. The conversion kit was purchased from V. C. Hobbys in San Diego, the Air Fix Hunter Kit from Wagon Wheel Hobbys, Phoenix, and the info from Profile #167, Airfix Magazine, plus my own files.

I see by the semi-official grapevine that Air Conversions are soon to have a kit for the two seat Lightning. This is a logical step as the lofting for the Hunter was used by English Electric to produce their trainer version, therefore some of the necessary pieces should be very similar. Also I seem to have half a dozen Air Fix kits for the EE Lightning just waiting for the scalpel.

TROPHIES & PRIZES
SCALE MODEL
SHOW
MARCH 17-18, 1973
 Griswold Inn, 555 W. Foothill Blvd., Claremont, Calif.
 in the Convention Center.

WHERE WE WERE

Dirty Plastic February 1973

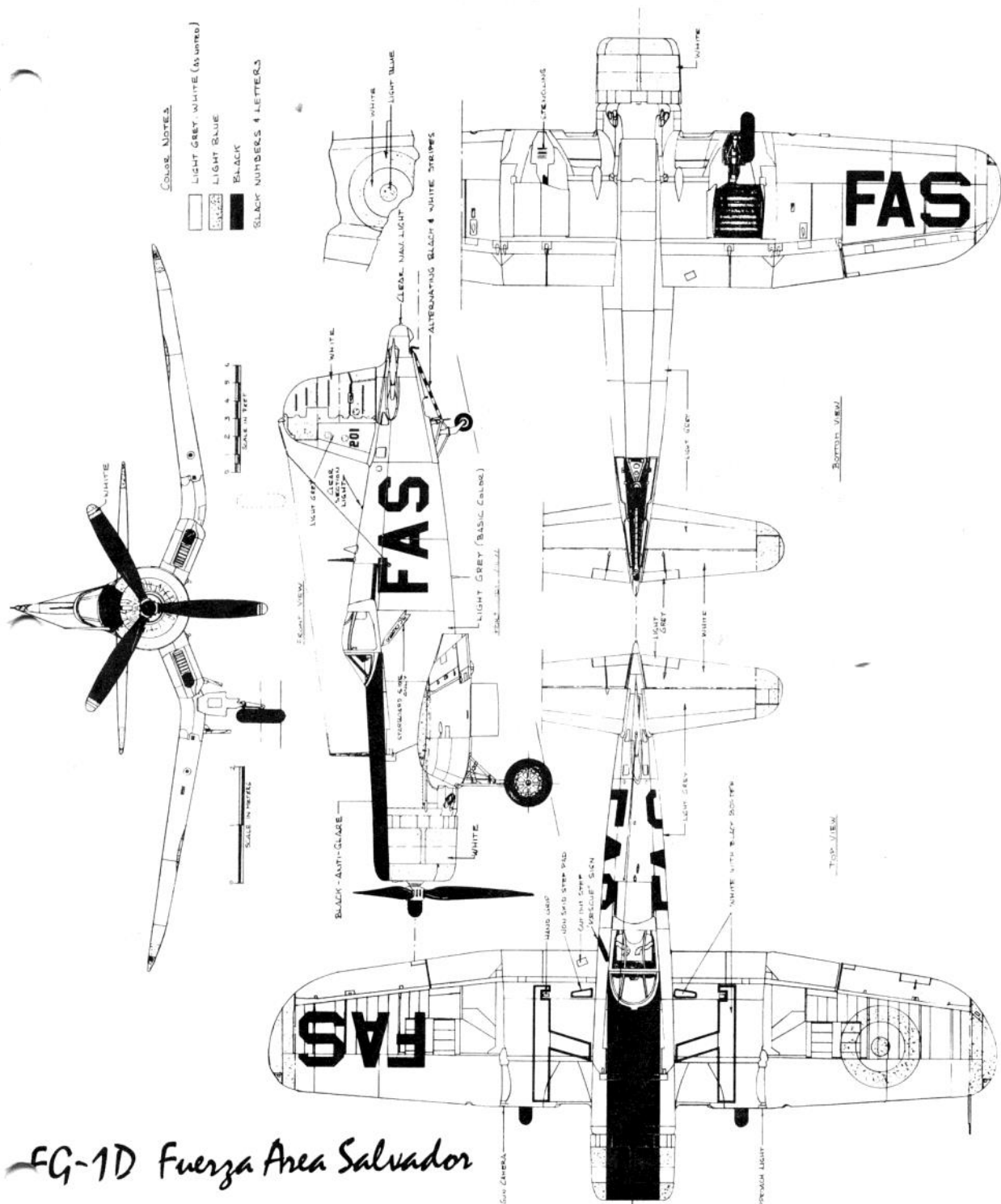

FG-1D Fuerza Area Salvador

1959 - GROUNDLOOPED AT EL PASO, TEXAS
FRONT 4 BAY RECONSTRUCTED AT NAF LIGHTFIELD
PARK, ARIZONA

DRAWN BY: HEINZ F. JACOBS 10-72
PHOTOGRAPHED BY BRIAN BAKER

WHERE WE WERE

Dirty Plastic February 1973

iranian H-43's

researched from existing aircraft by **BOB FORREST**

drawn by **C.K. KRAUSE**

June 72

DIRTY PLASTIC - FEB. 73

color scheme:

GLOSS WHITE

SERIALS

usaf

64-15099
64-15103
65-10654

iranian

2002 (4302) MEHABAD
2003 (4312) MENKASAD
2001 (4316) *

* CRASHED IN U.S. FOR MAJOR REPAIR TIME OF REPAIR.

NOTES on installation of the small belly lights, antenna and speakers. Serial numbers not listed are either not installed unknown:

Note A: 304, 305, 307, 310, 311, 313, 319, 321, 2001, 2003

Note B: (both): 310, 311, 313 (Aircraft centerline position only): 303, 304, 305, 319, 321, 2003.

Note C: 310, 313, 319, 321, 2002, 2003.

Loudspeakers: 307, 308, 310, 311, 2002.

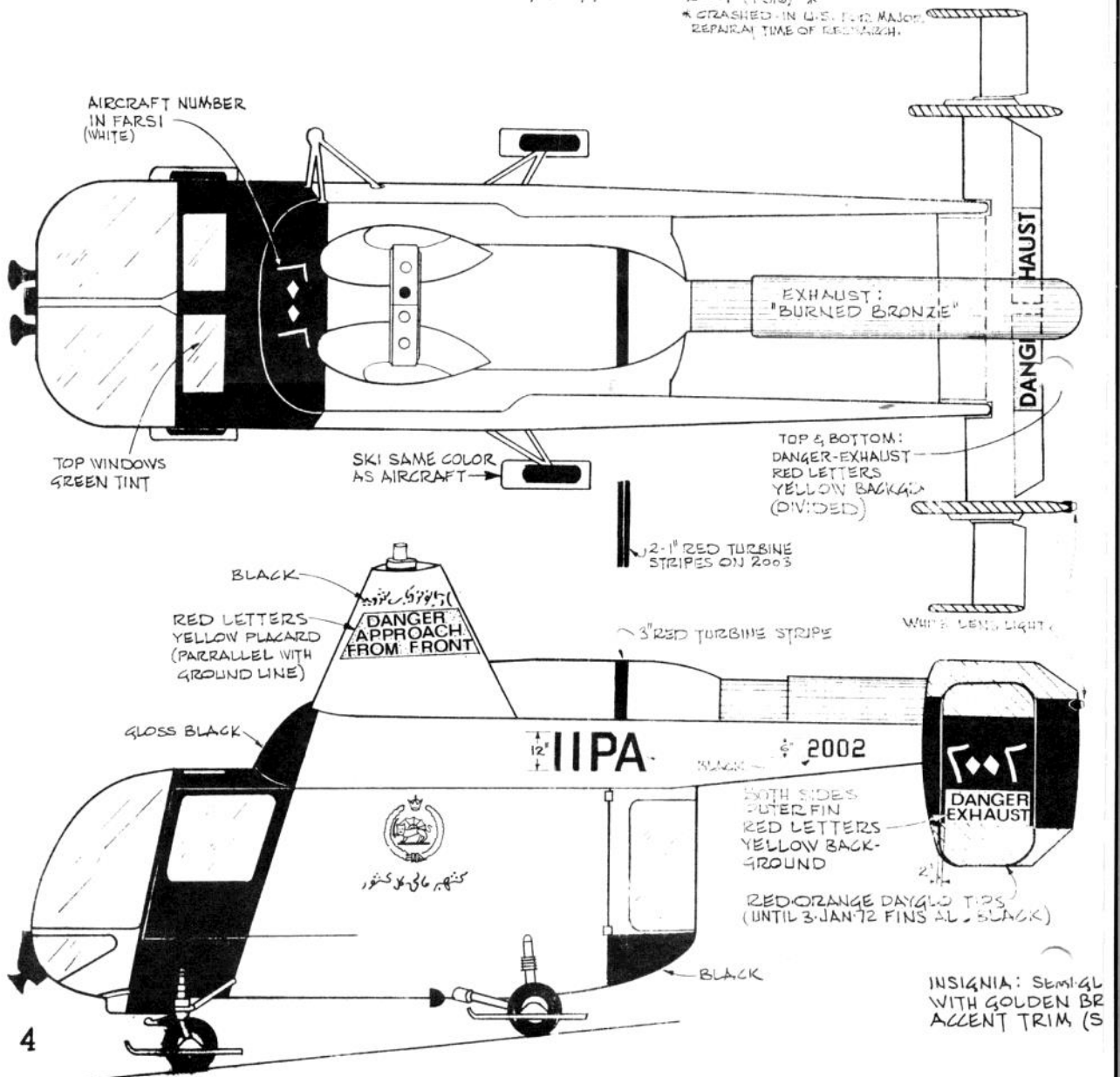

WHERE WE WERE

Dirty Plastic February 1973

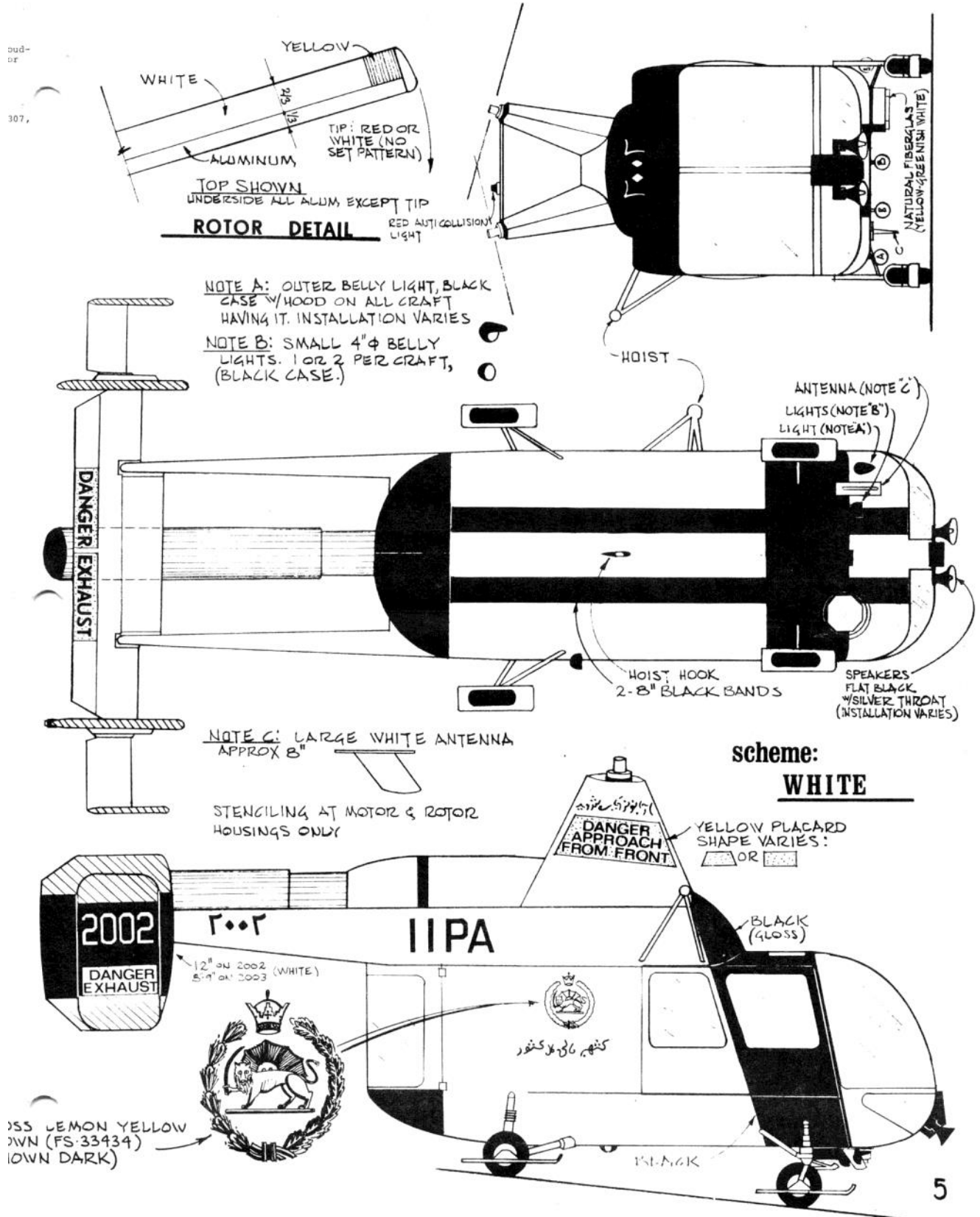

WHERE WE WERE

Dirty Plastic February 1973

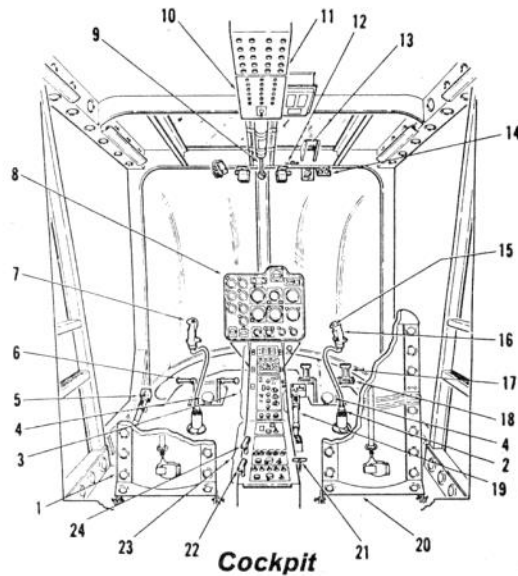

DRAWINGS
THIS PAGE
TAKEN FROM

H-43

T.O. 1H-43(H)B-1

U.S.A.F.
FLIGHT
MANUAL

Pilot's Seat



1. SEAT CUSHION
2. LAP BELT
3. SHOULDER HARNESS
4. SHOULDER HARNESS LOCK KNOB

Collective Pitch Levers

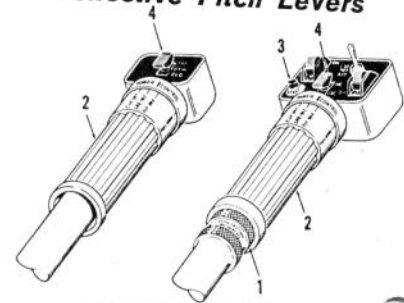

1. COLLECTIVE FRICTION NUT
2. THROTTLE
3. STARTER SWITCH
4. ENGINE SPEED GOVERNOR SWITCH

- | | | |
|--|---|---|
| <ol style="list-style-type: none"> 1. COPILOT'S SEAT 2. FRICTION NUT 3. UPPER CONSOLE 4. PEDAL ADJUSTING KNOB 5. COPILOT'S COLLECTIVE PITCH LEVER 6. COPILOT'S DIRECTIONAL PEDALS 7. COPILOT'S CYCLIC STICK GRIP 8. INSTRUMENT PANEL | <ol style="list-style-type: none"> 9. ROTOR BRAKE LEVER 10. CEILING CIRCUIT BREAKER PANEL 11. FUSE PANEL 12. EMERGENCY FLOTATION GEAR HANDLE 13. OUTSIDE AIR THERMOMETER 14. ROTOR TRACK SWITCHES 15. TRIM RELEASE BUTTON 16. PILOT'S CYCLIC STICK GRIP | <ol style="list-style-type: none"> 17. WHEEL BRAKE PEDALS 18. PILOT'S DIRECTIONAL PEDALS 19. PILOT'S COLLECTIVE PITCH LEVER 20. PILOT'S SEAT 21. MANUAL CARGO RELEASE LEVER 22. PARKING BRAKE HANDLE 23. LOWER CONSOLE 24. NOSE WHEEL LOCK HANDLE |
|--|---|---|

Pilot's, Copilot's, and Hoist Operator's Grips



1. MICROPHONE SWITCH
2. TRIM RELEASE SWITCH
3. HOIST UP-DOWN SWITCH
4. CABLE CUTTER BUTTON
5. SLING DROP BUTTON

Hoist Equipment

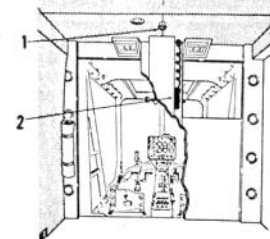

1. HOOK RETAINING RING
2. HOIST OPERATOR'S GRIP

Lighting System

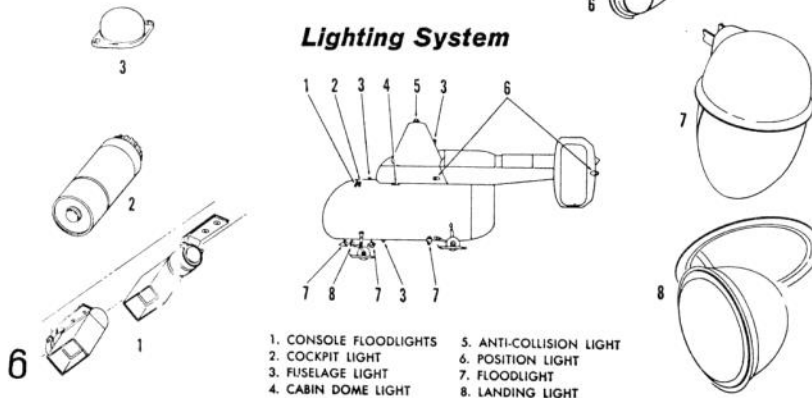

1. CONSOLE FLOODLIGHTS
2. COCKPIT LIGHT
3. FUSELAGE LIGHT
4. CABIN DOME LIGHT
5. ANTI-COLLISION LIGHT
6. POSITION LIGHT
7. FLOODLIGHT
8. LANDING LIGHT

Public Address System

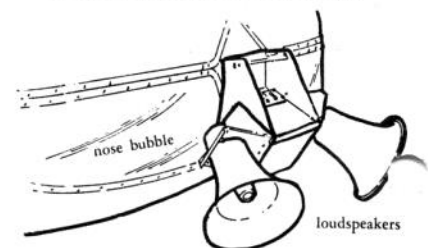

WHERE WE WERE

Dirty Plastic February 1973

PAINT SPOTS - UNITED STATES (Continued)



	Interior Green	(Type 1)	CKK
	FS 595 #34151		
	Floquil M49 Med. Green	8 parts	
	RR31 Yellow	22 parts	
	RR11 White	4 parts	
	RR10 Black	1 part	
	Zinc Chromate	(Type 2)	

Through my confusion last month I mentioned no hard and fast rule, but generally the type I was used on cockpits and other inhabited spaces while Type 2 was a primer, exposed only in mechanical areas (wheel wells, etc.), however I particularly noticed Type 2 in the main body of several transports in the Pima County Air Museum's inventory (PIMA PAISANOS - the only IPMS Chapter with their own AirForce).

In some places, the zinc chromate was touched up with a medium green that comes close to FS 34108 (there was a chip in D/P #13 and maybe we'll repeat it sometime in the future).

The above colors are from the Humbrol "Interior Colors" set.

Last month we reviewed Micro Scale's Quick Silver Putty. I understand they have now issued instructions for use - if you do purchase this be sure to obtain the printed instructions as it explains a lot.

(If all else fails, issue instructions?)

AIR MUSEUM NEWS

Don Sproule

December was a good month for the Museum. The fund drive is off the ground, a survey crew from the County has shot most of the lines, and we have started clearing the land inside the fence. Santa Claus was good to us, the P-5 (EX P-38L) was brought in from Blythe by Col. Arnold and Jim Davis just before Christmas. Rhodes, Jim, Paul Dion, and others now have much of the C-125 from Douglas on the Museum property. Just two more truck loads to go, the left wing section and the fuselage are left. The PG-1 (F4U) should be here about the end of the month, and we have some more goodies due in the next few months.

The Beechcraft AT-11 was brought into the Museum on January 21, and by the time you read this, we will have lights and water on the property.

The weekend of 3 Feb., the Marine Corps Reserve is coming with some heavy equipment to help us finish the land clearing. Then they will come back later. The Marines are landing!

My weekend from now on we will be working on the Museum, clearing, chipping, pouring concrete, restoring airplanes, etc., so put on some clothes, grab your tools and come on out. If you don't know how to get there, go South on I-10 to the Wilmont Exit, North to the C-124, left about 1/2 mile to the big fenced & lighted area on the left. If the big gate is open, we're there.

If you really want to start the new year right, send a check, kit, manual, pictures, or whatever you can to the Museum at: Pima County Air Museum, P. O. Box 1363, Tucson, Arizona 85702.

For those of you from outside Arizona who don't know about the Museum, write the above address for a book and update sheet. If you can send a dollar, it will help with the postage and other expenses. We have about 75 birds, including B-18, B-23, B-24, B-58, PBW-5A, C-133, P-80, P-63, and many others. If you're coming this way, stop and see us, or give me a call, Don Sproule (602) 885-9549.

Any contribution is welcome and tax deductible!

HAPPY NEW YEAR!

PRESIDENTS PAGE - TUCSON

Don Sproule

Hangovers gone? Christmas Tree Down? Now its time to get back to some serious plastic bashing. Many interesting things have happened in the past months, be sure to read the Air Museum column.

By accident, we have located the molds for the old Allyn Kits, in California. To jog your memory, they put out kits in many scales, such as the Douglas A-1, A3D, F3D, F4D, A2D, Skystreak, Skyrocket, all in 1/48th, Boeing B-47 & KC-97, and others. If any of you are interested in seeing these kits reissued, drop me a line or a card at P. O. Box 1363, Tucson, 85702. With enough interest, possibly we can get at least a limited run put out. United we stand, etc.

We are no longer having meetings at Empire Mach. Co. here in Tucson. We will be meeting at various members homes, for awhile anyway. Any questions, call me at 885-9549. Hopefully, we will have a permanent meeting place at the Museum very shortly.

Our display this month is small Air Force's, any period.

The kit reissue bug has really bit. Monogram has reissued their old armour, including the Weasel, Jeep, 1/2 Track, & etc. Revell of England has reissued the F-89. These and other kits have been seen at Tucson Train.

The tour of D.M. & the Museum Birds was quite good, everyone seemed to enjoy it.

Air and DM's A & A days are coming up soon, and the Mesa Show is on, so let's bash some kits to sell. Remember, profits to the Museum.

Ed's Hobby Haven, formerly Townsend's, has come up with some old aircraft and car kits. The aircraft are going to the Museum, but we have some old car kits for trade, including some AMT 3 in 1 kits, drop me a line if you need some.

SUPPORTING HOBBY SHOPS

- Phoenix** Val's Hobby Hanger - 4840 N. 59th Avenue
 Webster's Hobby Shop - 30 E. Camelback Road
 Wagon Wheel Hobbies - 4314 E. Thomas Road
- Tucson** The Hobby Hut - 4578 E. Broadway
 Ed's Hobby Haven - 2751 N. Campbell
 Jack's Hobbies, Woolco Center, Kolb & Broadway
 Tucson Train - 4352 E. Speedway

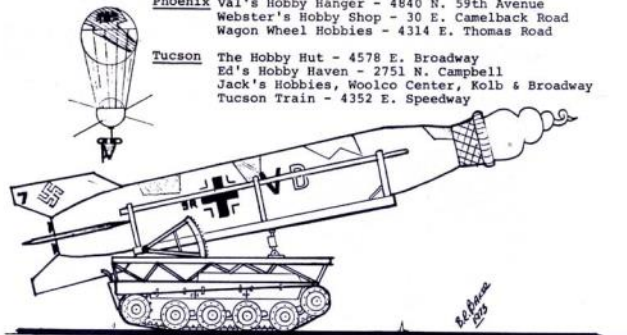

OBSCURE (VERY) GERMAN ARMOUR, SERIES II

Brian R. Baker

PzW. XIII V2SiW with A-4S/R1 Missile

Dubbed the V2Ersatzzellitewagen by the development staffs, the V2SiW version of the PzW. XIII was evolved by Doktor Werner von Braun's research group at Pennemunde, on the Baltic Coast. Strange as it may seem, the V2SiW variant actually came about as a direct result of the R.A.F.'s first 1,000 plane bombing raid on the Army's rocket research center on the night of February 30, 1944. The very successful incendiary attack set off disastrous fires, and the resulting chaos in the blueprint storage area somehow caused the prints of the A-4 missile (V-2) to be merged with a set of blueprints of a rare photoreconnaissance variant of the original Montgolfier balloon. The result was truly unique in the history of aerial warfare - - - the first "Spy in the Sky" satellite.

The V2S, or A-4S/R1 missile/satellite combination, was transported and launched from the PzW. XIII V2SiW tank carriage, as illustrated. The standard A-4 warhead was replaced by the satellite in compact form, complete with a folded up hydrogen balloon. (The dirty Yanks still refused to sell any helium to the Germans, despite the Hindenburg incident.) When the satellite reached orbital altitude, the balloon automatically inflated, and served as an altitude regulating device. Cruising altitude, originally specified as fifteen meters, was later increased to eighteen by direct order of the Fuhrer, while orbital velocity, first calculated at six knots, was later raised to eleven by the installation of a hydrogen ejector valve installed in the side of the balloon. The photoreconnaissance version carried a 122 size Voigtlander folding bellows camera mounted on a leather strap hanging below the satellite. The shutter was actuated by a Zeiss timing mechanism, and photos were possible even on cloudy days.

The first operational use of the A-4S/R1, launched from PzW. XIII V2SiW's occurred during the preliminary operations associated with the German Ardennes offensive during the winter of 1944-45. The plan was to have the satellites obtain photos of the critical Bastogne region, but, unfortunately, a strong northeasterly gale, variously estimated at from ten to twelve knots, blew the satellite off course, resulting in some remarkably clear, but militarily useless, photos of the red light district in Cairo, Egypt. The only military result of this operation was, therefore, the subsequent discovery of these photos by advancing Israeli forces during their 1956 offensive sweep through the Sinai Desert, which prompted Israeli military leaders to abandon Cairo as a military objective.

H-43 AIRCRAFT MARKING SPECIFICATION (SEE FIGURE 3-43)

1. MARKING	2. LOCATION	3. SIZE	4. COLOR
A. U.S. Air Force	Both sides of fuselage and tail boom	Letters 8" high	-Code 15044
B. Model Designation, Aircraft Serial No. & Fuel Requirements	Left side of fuselage	Letters and numbers 1" high	-Code 17038
C. National Star	Both sides of fuselage	20 inch star	Background, Border, -Code 15044. Stars, Bars - Code 17875. Stripes - Code 509
D. National Star	On underside of fuselage	20 inch star	Background, Border, -Code 15044. Stars, Bars - Code 17875. Stripes - Code 509
E. National Star	On top engine cowl	20 inch star	Background, Border, -Code 15044. Stars, Bars - Code 17875. Stripes-Code 509.
F. Call Numbers	Both sides of vertical stabilizer	Number 6 inches high	-Code 17038
G. Arctic Markings	On outside surface of vertical stabilizer		-Code 633
H. Anti-Glare			-Code 37038
I. Orange-Yellow Bands (ARS Only)	Both sides of tail booms		Band -Code 13538 Border -Code 17038
J. Walkways		Border 2 inches wide	-Code 17038

WHERE WE WERE

Dirty Plastic February 1973

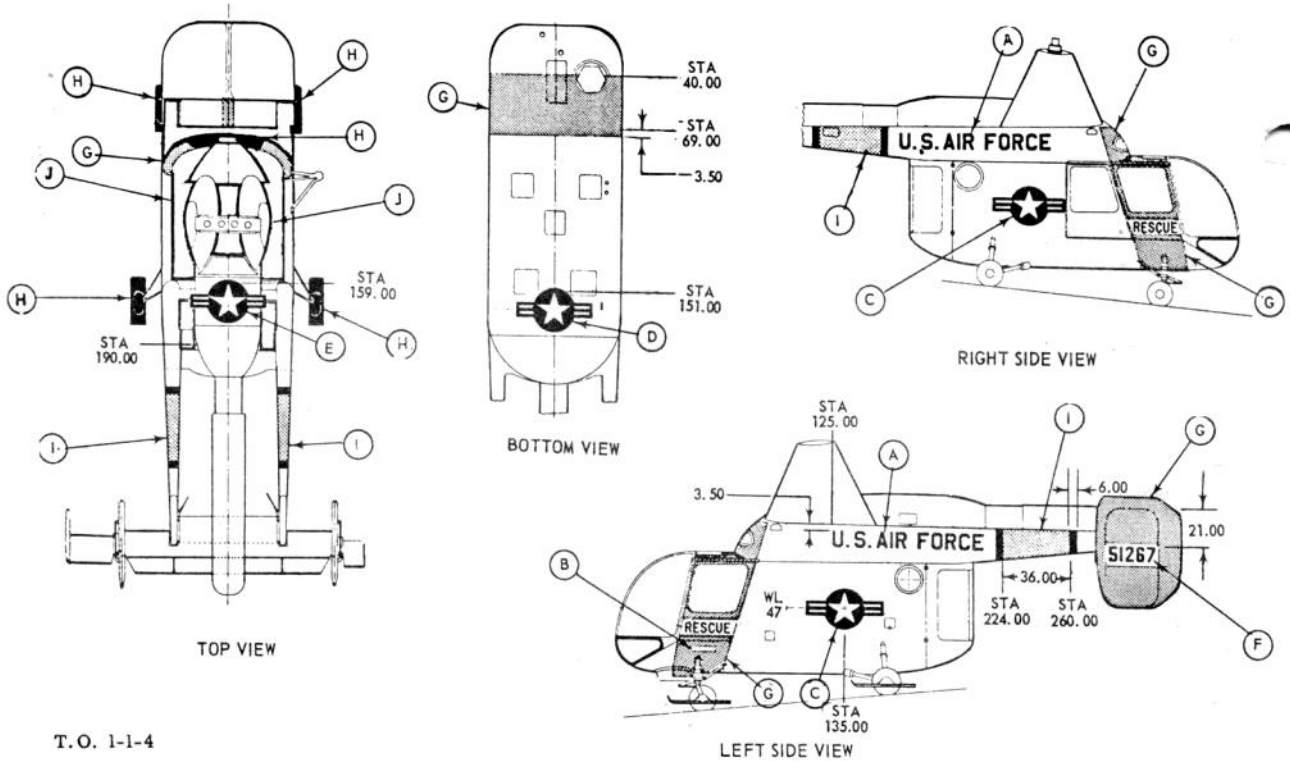

T.O. 1-1-4

H-43 Aircraft Marking Specification

Figure 3-43.

Address Correction Requested

dirty plastic

ARIZONA HISTORICAL MODELERS SOCIETY IPMS/Phoenix
PJMA PAISANOS IPMS/Tucson
2033 N. 11th Ave. Phoenix, Arizona 85007

This is the number of your
LAST ISSUE - - - - -



FIRST CLASS

Membership

For only \$1 a month you get all of this

- . Monthly club newsletter**
- . Discounted club T-shirts**
- . Modelzona**
- . Monthly Raffle Prizes**
- . Monthly contest awards**
- . Annual club Awards party**
- . And more**

Remember that you have to be a member **in good standing to enter and win competitions, get a copy of the monthly newsletter sent directly to your email, and vote for anything that the club brings to the table.**

So Make sure to see Treasurer, “Bill Dunkle”, at the club meeting to sign up for membership

2024 CLUB MEETING CALENDAR

All meetings held at American Legion Post #1, 364 N. 7th Ave., Phoenix, AZ 85003

JANUARY 2024

Tuesday 2nd 7pm
Seminar/Speaker: Uncommon but
useful tools—Kevin Henthorn

JULY 2024

Tuesday 2nd, 7pm
Seminar/Speaker:

FEBRUARY 2024

Tuesday 6th 7pm
Seminar/Speaker: Resin/Mike
Mackowski

AUGUST 2024

Tuesday 6th 7pm
Event : **Club Swapmeet**

MARCH 2024

Tuesday 5th, 7pm
Seminar/Speaker: Wiring Bi-Planes/
Brian Baker

SEPTEMBER 2024

Tuesday 3rd, 7pm
Seminar/Speaker:

APRIL 2024

Tuesday 2nd 7pm
Seminar/Speaker:

OCTOBER 2024

Tuesday 1st, 7pm
Seminar/Speaker:

MAY 2024

Tuesday 7th, 7pm
Seminar/Speaker:

NOVEMBER 2024

Tuesday 5th 7pm
Seminar/Speaker:

JUNE 2024

Tuesday 4th 7pm
Seminar/Speaker:

DECEMBER 2024

Tuesday 10th 7pm
Event: **White Elephant**



February Raffle

Tickets are \$1 or six for \$5.

Item A: 1/144 Minicraft, USAF EC-121R Lockheed Constellation



Item B: 1/72 LS, Ki-46 "Dinah"



Item C: 1/350 Trumpeter USS England DE-635



Item D: 1/35 Testors/Italeri M-1 Anti-Tank Gun



Item E: New Item from Hobby Depot 1/35 Airfix, Ferret Scout Car Mk.2



Item F: New Item from Hobby Depot 1/48 Airfix, Westland Sea King



Item G: **Special \$5/ticket** - 1/32 Hasegawa, Junkers JU-87G "Stuka" includes metal pilot figure, and after-market resin wheels, propeller, spinner and brass pitot tube from Voyager Model

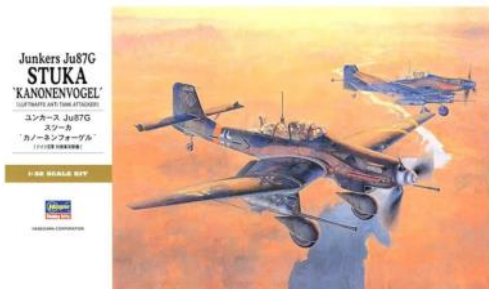

UPCOMING EVENTS

April 13th - DSC
November 2nd - Modelzona

IPMS Phoenix / Craig Hewitt Chapter

The club meets at 7pm on the first Tuesday of each month at the American Legion Post #1 in Phoenix. Check the club website at www.ipms-phoenix.com for more meeting info.

American Legion Post #1

364 N. 7th Ave.
Phoenix, AZ 85003

The post is located South of I-10 just a few blocks North of Van Buren. Look for the huge American flag.

2024 Chapter Officers

President.....	Kevin Henthorn.....	http://www.ipms-phoenix.com/
Vice President.....	Scott Reigel.....	http://www.ipms-phoenix.com/
Secretary	John Carroll	http://www.ipms-phoenix.com/
Treasurer	Bill Dunkle.....	http://www.ipms-phoenix.com/
Member At Large.....	Hal Sanguinetti.....	http://www.ipms-phoenix.com/
Membership Chair.....	Lyn Gorton.....	http://www.ipms-phoenix.com/
Webmaster.....	Michael Ronnau.....	http://www.ipms-phoenix.com/
Newsletter Editor	Lyn Gorton	lyngorton@hotmail.com

Useful Links

Bjorn Jacobsen—Aircraft Dioramas	www.dioramas-and-models.com
Plasmo—good visual instructions on “You Tube”	just search for plasmo
Trumpeter replacement parts	Joanna@trumpeter-china.com
Special Hobby	www.specialhobby.Ev/contact
Tamiya—US	support@Tamiya.com
MRCsupport@modelrectifier.com	
Rivet detail and schematic drawings	www.airwar.ru
Fine Scale modeling techniques	http://paulbudzik.com
“How to “Videos	Youtube.com/Andyshobbyheadquarters
Online magazine for all things avionic	www.wingleadermagazine.co.uk
Sky Harbor Informational site	http://www.visitingphx.com/index.html
Military Colors And Camouflage	http://www.theworldwars.net/resources/
Info on Aircraft Tyres	https://www.jupitor.co.jp/pdf/michelin_aircraft.pdf
Spare parts for Airfix	support.airfix.com/hc/en-gb/articles/360019394159-Spare-Parts
Video tour of USAF Museum in Ohio	https://aerodynamicmedia.com/usaf-museum-storage-video/
New digital magazine	www.phoenixscalepublications.co.uk
Swiss page covering aviation.	
Wide range of military subjects, airshows, color profiles, etc.	WINGS-AVIATION , www.wings-aviation.ch .
WW2 Video reference Site –Lots of Documentary DVD	www.victoryfilms.us

If you have a good reference site let me have a brief description and a web address and we will keep this list as a reference.

Join the IPMS/USA!

\$30 annual membership includes a one year subscription to the IPMS Journal. Visit www.ipmsusa.org to download a membership form. Or you can write to:



IPMS/USA PO Box 1411
Riverview,
FL 33568-1411

Membership also gives you access to the online Discussion Forum, where you can exchange ideas and information with other members of IPMS.



CONTENT NEEDED!!!!

The Corsair needs your help! To keep this newsletter filled with all the great content, I need your help with content. Here are some useful items that I can use to put together future issues each month:

- Kit reviews/In-box reviews
- Website links
- Modeling related articles
- Commentary and featured columns
- Neat, strange or otherwise shareable pictures
- Book reviews
- Trip and vacation write-ups

Anything you have can be used. Don't hesitate. Even a few paragraphs are great.



SUPPORT YOUR LOCAL HOBBY SHOP!



RIGHT STUFF, RIGHT PRICE
www.thehobbydepot.com

109 E. Southern Ave.
 Tempe, AZ 85282



KEITH PEIPER, MANAGER

(480) 994-2263
 AVALON_WAR_BOOKS@YAHOO.COM

WE BUY COLLECTIONS



Rhino's Hobby Tools & More

Michael Ronnau
 cactus_rhino@cox.net

www.airline-hobby.com



Space modeling reference books by Mike Mackowski.

www.spaceinminiature.com

Your One Stop Source for Scale Model Airliner Kits, Decals, Diecasts and Accessories



THE MAD MEATBALL

MIKE CHOLEWA 602-944-4096

"DEALER IN PRE-OWNED PLASTIC"

12629 NORTH 21ST DRIVE PHOENIX, AZ 85029

HOBBY BENCH

2 Great Locations!

8058 N. 19th Ave. NW corner 19th Ave. & Northern 602-995-1755	4240 W. Bell Rd. NE corner 43rd Ave. & Bell 602-547-1828
--	---



ANDY'S HOBBY HEADQUARTERS



15224 N. 59th Avenue, Suite 12
 Glendale, AZ, 85306
 tel. (602) 439-1456



Scott Cohen

Marketing, Finance, Product Development, Supply Chain, Inventory & QC/QA

Post Office Box 74524
 Phoenix, AZ, 85087-4524
 tru.colorpaint1@yahoo.com

Tru-Color Paint
 Model Railroad, Automobile, and Building Paint

Sales: (714) 488-9779
 Info: (623) 551-2548
www.trucolorpaint.com

SUPPORT YOUR LOCAL HOBBY SHOP!



GRAND PRIX REPRODUCTIONS

JEFF ALDERMAN

MASTER MODELER

jeff@grandprixreproductions.com

(623) 385-9060



WWW.GRANDPRIXREPRODUCTIONS.COM