

# MAINTENANCE BEST PRACTICES OF HYDRAULIC SYSTEMS

BY: **RICKY SMITH,  
CMRP, CMRT, CRL**

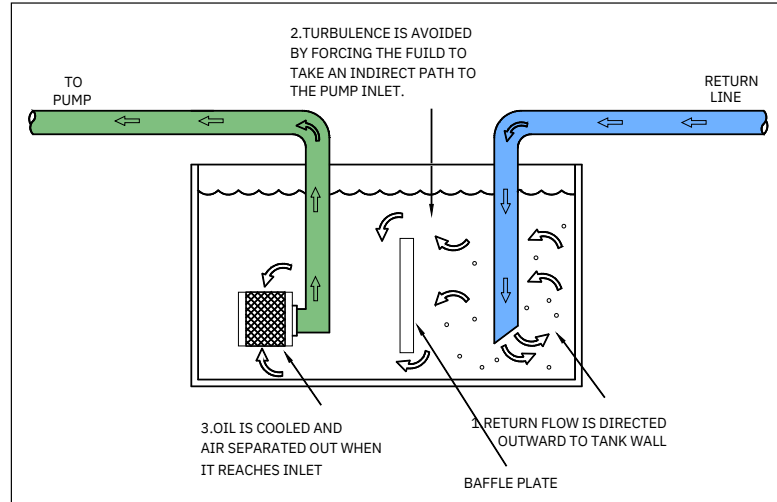



Most companies spend a lot of money training their maintenance personnel to troubleshoot a hydraulic system. If we focused on preventing system failure then we could spend less time and money on troubleshooting a hydraulic system. We normally expect hydraulic system failure rather than deciding not to expect hydraulic failure as the norm. Let's spend the time and money to eliminate hydraulic failure rather than preparing for failure. I worked for Kendall Company in the 1980's and we changed our focus from reactive to proactive maintenance on our hydraulic systems and thus eliminating unscheduled hydraulic failure. We will talk about the right way to perform maintenance on a hydraulic system utilizing the "Maintenance Best Practices of Hydraulic System".

Lack of maintenance of hydraulic systems is the leading cause of component and system failure yet most maintenance personnel don't understand proper maintenance techniques of a hydraulic system. The basic foundation to perform proper maintenance on a hydraulic system has two areas of concern. The first area is Preventive Maintenance which is key to the success of any maintenance program whether in hydraulics or any equipment which we need reliability. The second area is corrective maintenance, which in many cases can cause additional hydraulic component failure when it is not performed to standard.

## Preventive Maintenance

Preventive Maintenance of a hydraulic system is very basic and simple and if followed properly can eliminate most hydraulic component failure. Preventive Maintenance is a discipline and must be followed as such in order to obtain results. We must view a PM program as a performance oriented and not activity oriented. Many organizations have good PM procedures but do not require maintenance personnel to follow them or hold them accountable for the proper execution of these procedures. In order to develop a preventive maintenance program for your system you must follow these steps:

1st: Identify the system operating condition.

a. Does the system operate 24 hours a day, 7 days a week?

- b. Does the system operate at maximum flow and pressure 70% or better during operation?
  - c. Is the system located in a dirty or hot environment?
- 2nd: What requirements does the Equipment Manufacturer state for Preventive Maintenance on the hydraulic system?
- 3rd: What requirements and operating parameters does the component manufacturer state concerning the hydraulic fluid ISO particulate?
- 4th: What requirements and operating parameters does the filter company state concerning their filters ability to meet this requirement?
- 5th: What equipment history is available to verify the above procedures for the hydraulic system?

As in all Preventive Maintenance Programs we must write procedures required for each PM Task. Steps or procedures must be written for each task and they must be accurate and understandable by all maintenance personnel from entry level to master.

Preventive Maintenance procedures must be a part of the PM Job Plan which includes: Tools or special equipment required performing the task.

Parts or material required performing the procedure with store room number.

Safety precautions for this procedure.

Environmental concerns or potential hazards.

**Preventive Maintenance Procedure Example**

Equipment Block ID: Line 101			
Equipment Hierarchy: E560XXX Scepter Process Line			
Project Description: Perform PM on Scepter Process Line			
Job Description: Perform PM on Hydraulic System			
Frequency: Monthly			
Estimated Craft Hours: 2 techs x 3.0 hrs	Estimated Elapsed Time: 3.0		
Estimated Production Downtime: 3.0			
Originator: Dave Stone	Origination Date: 03/12/2012		
Owner: Plant Maintenance	Version #: 1.0		
Previous Version(s) Modifications:			
Approval: DS	Version #: 1.0		
<b>Warnings:</b> Failure to follow instructions could lead to death or serious injury			
<b>Cautions:</b> Failure to follow procedure could result in early equipment failure			
Personal Protective Equipment Required: Gloves, face shield, hearing protection			
Part # (Stores ID)	Part Description	Quantity	Quantity Description
#83214	Hydraulic Filter	2	Each
#82543	Zinc Anode	1	Each
Consumables Needed: Degreaser, lint free towels, thread seal			
Special Tools Required: 1 Torque Wrench			
Mobile/Special Equipment: None			
Required Departmental Coordination: Production Line shutdown / Hydraulic Cylinder Extended / One Operator to Assist Maintenance			
Other Procedures Referenced: Job Preparation / Lockout Procedure #100X			

**Preventive Maintenance Procedure Example**

Step#	Description	Craft	# of Crafts	Clock Hours	Craft Hours	Craft Initials
1	Inspect Hydraulic System Running • Does the Pressure Fluctuate more than 5psi? YES / NO • Number of Hydraulic Leaks	Mech	2	.5	1.0	JRP
2	<b>Caution: Failure to Clean inside reservoir will result in premature valve failure</b>	Mech	2	25	5	JRP
2	Clean inside Reservoir with Lint Free Rags	Mech	2	1.0	2.0	JRP
3	Replace Hydraulic Filters (2)	Mech	1	0.3	0.3	JRP
4	Torque Fasteners on Filter Fasteners to ( )					
4	Replace Zinc Anode on Water Cooled Heat Exchanger	Mech	1	.5	.5	JRP
5	Inspect 5 Hydraulic Hoses for wear or leaks • Hose 1.1 Yes / No • Hose 1.2 Yes / No • Hose 1.3 Yes / No • Hose 1.4 Yes / No	Mech	2	1	2	JRP
6	Inspect Hydraulic Cylinder for Leaks • Inspect Rod Seal for Leaks (Circle One) No Leaks Weeping Oil Oil Stream • Inspect Rod Yoke for break in thread seal on threads Breaks? Yes / No	Mech	1	0.3	0.3	JRP
7	Inspect all work after production is up to rate "Do not leave equipment until production is up to rate"	Mech	2	.5	1.0	
<b>TOTAL Hours</b>				<b>4.35</b>	<b>7.0</b>	
<b>Condition (As Found):</b> 3 leaking hoses						
<b>Condition (As Left):</b> Clean reservoir and area, tightened hose fittings						

Figure 1. Example a Basic Hydraulic Preventive Maintenance Procedure

A list of Preventive Maintenance Task for a Hydraulic System could be:

1. Change the (could be the return or pressure filter) hydraulic filter.
2. Obtain a hydraulic fluid sample.
3. Filter hydraulic fluid.
4. Check hydraulic actuators.
5. Clean the inside of a hydraulic reservoir.
6. Clean the outside of a hydraulic reservoir.

## Maintenance Best Practices of Hydraulic Systems

7. Check and record hydraulic pressures.
8. Check and record pump flow at a specific pressure.
9. Check hydraulic hoses, tubing and fittings for leaks.

“When hydraulic fluid leaks out of fitting as oil goes out, contamination is pulled in”

10. Check and record voltage reading to proportional or servo valves.
11. Check and record vacuum on the suction side of the pump.
12. Check and record amperage on the main pump motor.
13. Check machine cycle time and record.

Preventive Maintenance is the core support that a hydraulic system must have in order to maximize component and life and reduce system failure. Preventive Maintenance procedures that are properly written and followed properly will allow equipment to operate to its full potential and life cycle. Preventive Maintenance allows a maintenance department to control a hydraulic system rather than the system controlling the maintenance department. We must control a hydraulic system by telling it when we will perform maintenance on it and how much money we will spend on the maintenance for the system. Most companies allow the hydraulic system to control the maintenance on them, at a much higher cost.

In order to validate your preventive maintenance procedures you must have a good understanding and knowledge of “Best Maintenance Practices” for hydraulic systems. We will convey these practices to you.

<i>Best Maintenance Practices for Hydraulic Systems</i>			
Component	Component Knowledge	Best Practices	Frequency
Hydraulic Fluid Filter	There are two types of filters on a hydraulic system. 1.) Pressure Filter - Pressure filters come in collapsible and non-collapsible types. Preferred filter is the non-collapsible type. 2.) Return Filter - Typically has a bypass, which will allow contaminated oil to bypass the filter before indicating the filter needs to be changed.	<ol style="list-style-type: none"> <li>1. Clean the filter cover or housing with a cleaning agent and clean rags.</li> <li>2. Remove the old filter with clean hands and install new filter into the filter housing or screw into place. CAUTION: NEVER allow your hand to touch a filter cartridge. Open the plastic bag and insert the filter without touching the filter with your hand.</li> </ol>	Preferred: based on historical trending of oil samples. Least Preferred: Based on equipment manufacture’s recommendations.
Reservoir Air Breather	The typical screen breather should not be used in a contaminated environment. A filtered air breather with a rating of 10 micron is preferred because of the introduction of contaminants to a hydraulic system.	<ol style="list-style-type: none"> <li>1. Remove and throw away the filter.</li> </ol>	Preferred: Based on historical trending of oil samples. Least Preferred: Based on equipment manufacture’s recommendations
Hydraulic Reservoir	A reservoir are used to: <ol style="list-style-type: none"> <li>1. Remove contamination.</li> <li>2. Dissipate heat from the fluid.</li> <li>3. Store a volume of oil.</li> </ol>	<ol style="list-style-type: none"> <li>1. Clean the outside of the reservoir to include the area under and around the reservoir.</li> <li>2. Remove the oil by a filter pump into a clean container, which has not had other types of fluid in it before.</li> <li>3. Clean the insides of the reservoir by opening the</li> </ol>	<p>If any of the following conditions are met.</p> <ol style="list-style-type: none"> <li>1. A hydraulic pump fails.</li> <li>2. If the system has been opened for major work.</li> </ol>

		<p>reservoir and cleaning the</p> <p>3. If an oil analysis</p> <p>4. Afterwards spray clean states hydraulic fluid into the excessive reservoir and drain out of the contamination</p>	
Hydraulic Pumps	<p>A maintenance person needs to know the type of pump they have in the system and determine how it operates in their system. Example: What is the flow and pressure of the pump during a given operating cycle. This information allows a maintenance person to trend potential pump failure and troubleshoots a system problem quickly.</p>	<p>1. system.</p> <p>2. Check and record flow and Pressure checks: pressure during specific Preferred - operating cycles. Daily</p> <p>3. Review graphs of pressure Least Preferred: and flow. Weekly</p> <p>Check for excessive fluctuation of the hydraulic system. Flow &amp; Pressure (designate the fluctuation checks: allowed) Preferred- Two weeks Least preferred Monthly</p>	

Figure 2. Maintenance Practices for Hydraulic Systems

### Hydraulic Knowledge

People say knowledge is power. Well this is also true in hydraulic maintenance. Many maintenance organizations do not know what their maintenance personnel should know. I believe in an industrial maintenance organization that we should divide the hydraulic skill necessary into two groups. One is the hydraulic troubleshooter, they must be your experts in maintenance and this should be as a rule of thumb 10% or less of your maintenance workforce. The other 90% + would be your general hydraulic maintenance personnel. They are the personnel that provide the preventive maintenance expertise. The percentages I gave you are based on a company developing a true Preventive / Proactive maintenance approach to their hydraulic systems. Let's talk about what the hydraulic troubleshooter knowledge and skills.

Hydraulic Troubleshooter:

Knowledge –

- Mechanical Principles / force, work, rate, simple machines

- Math / basic math, complex math equations

- Hydraulic Components / application and function of all hydraulic system components.

- Hydraulic Schematic Symbols / understanding all symbols and their relationship to a hydraulic system.

- Calculate flow, pressure, and speed.

- Calculate the system filtration necessary to achieve the system's proper ISO particulate code.

Skill –

- Trace a hydraulic circuit to 100% proficiency.

- Set the pressure on a pressure compensated pump.

- Tune the voltage on an amplifier card.

- Null a servo valve.

- Troubleshoot a hydraulic system and utilize "Root Cause Failure Analysis".

- Replace any system component to manufacturer's specification.

- Develop a PM Program for a hydraulic system.

- Flush a hydraulic system after a major component failure.

## Maintenance Best Practices of Hydraulic Systems

### General Hydraulic:

#### Knowledge –

Filters / function, application, installation techniques

Reservoirs / function, application

Basic hydraulic system operation

Cleaning of hydraulic systems

Hydraulic lubrication principles

Proper PM techniques for hydraulics

#### Skills –

Change a hydraulic filter and other system components.

Clean a hydraulic reservoir.

Perform PM on a hydraulic system.

Change a strainer on a hydraulic pump.

Add filtered fluid to a hydraulic system.

Identify potential problems on a hydraulic system.

Change a hydraulic hose, fitting or tubing.

## Measuring and Tracking Success

In any program we must track success in order to have support from management and maintenance personnel. We must also understand that any action will have a reaction, negative or possible. We know successful maintenance programs will provide success, but we must have a checks and balances system to ensure we are on track.

In order to measure success of a hydraulic maintenance program we must have a way of tracking success but first we need to establish a benchmark. A benchmark is method by which we will establish certain key measurement tools that will tell you the current status of your hydraulic system and then tell you if you are succeeding in your maintenance program.

Before you begin the implementation of your new hydraulic maintenance program it would be helpful to identify and track the following information.

1. Track all downtime (in minutes) on the hydraulic system with these questions answered. / Tracked daily /

What component failed?

Cause of failure?

Was the problem resolved?

Could this failure have been prevented?

2. Track all cost associated with the downtime. / tracked daily /

Parts and material cost?

Labor cost?

Production downtime cost?

Any other cost you may know that can be associate with a hydraulic system failure.

3. Track hydraulic system fluid analysis. Track the following from the results. / take samples once a month /

Copper content

Silicon content

H2O

Iron content

ISO particulate count

Fluid condition (Viscosity, additives, and oxidation).

When the tracking process begins you need to trend the information that can be trended. This allows management the ability to identify trends that can lead to positive or negative consequences.

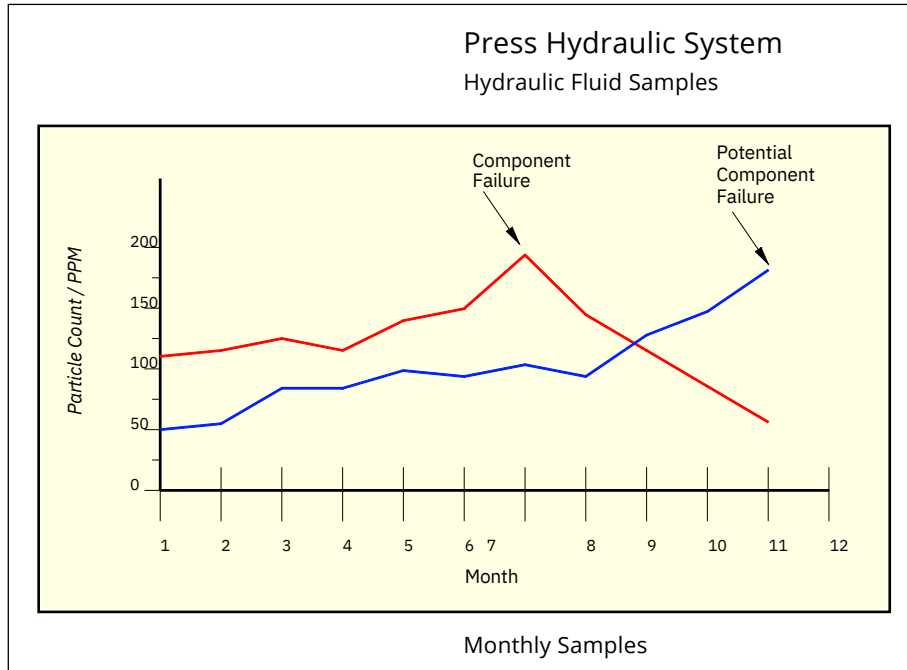

Figure 3. Hydraulic Fluid Samples

Fluid analysis proved the need for better filtration. The addition of a 3-micron absolute return line filter to supplement the “kidney loop” filter solved the problem.

Many organizations do not know where to find the method for tracking and trending the information you need accurately. A good Computerized Maintenance Management System can track and trend most of this information for you.

### Recommended Maintenance Modifications

Modifications to an existing hydraulic system need to be accomplished professionally. A modification to a hydraulic system to improve the maintenance efficiency is important to a company’s goal of maximum equipment reliability and reduced maintenance cost.

1st: Mobile Filtration pump with accessories:

Objective: The objective of this pump and modification is to reduce contamination that is introduced into an existing hydraulic system through the addition of new fluid and the device used to add oil to the system.

Additional Information: Hydraulic fluid from the distributor is usually not filtered to the requirements of an operating hydraulic system. Typically, this oil is strained to a mesh rating and not a micron rating. How clean is clean? Typically, hydraulic fluid must be filtered to 10 microns absolute or less for most hydraulic system, 25 microns is the size of a white blood cell, and 40 microns is the lower limit of visibility with the unaided eye.

Many maintenance organizations add hydraulic fluid to a system through a contaminated funnel and may even use a bucket that has had other types of fluids and lubricants in them previously, without cleaning them.



Figure 4. Filter Pumping Unit

### Recommended equipment and parts:

- Portable Filter Pump with a filter rating of 3 microns absolute.

  - Quick disconnects that meet or exceed the flow rating of the Portable Filter Pump.

  - A  $\frac{3}{4}$ " pipe long enough to reach the bottom of a hydraulic container your fluids are delivered in from the distributor.

  - A 2" reducer bushing to  $\frac{3}{4}$ " npt to fit into the 55 gallon drum, if you receive your fluid by the drum. Otherwise, mount the filter buggy to the double wall "tote" tank supports, if you receive larger quantities.

  - Reservoir vent screens should be replaced with 3 to 10 micron filters, an openings around piping entering the reservoir sealed.

Show a double wall tote tank of about 300 gallons mounted on a frame for fork truck handling, with the pump mounted on the frame work.

Also show pumping from a drum mounted on a frame for fork truck handling, sitting in a catch pan, for secondary containment, with the filter buggy attached.

Regulations require that you have secondary containment, so make everything "leak" into the pan.

### 2nd. Modify the Hydraulic Reservoir

Objective: The objective is to eliminate the introduction of contamination through oil being added to the system or contaminants being added through the air intake of the reservoir. A valve needs to be installed for oil sampling.

Additional Information: The air breather strainer should be replaced with a 10-micron filter if the hydraulic reservoir cycles. A quick disconnect should be installed on the bottom of the hydraulic unit and at the  $\frac{3}{4}$  level point on the reservoir with valves to isolate the quick



## Maintenance Best Practices of Hydraulic Systems

disconnects in case of failure. This allows the oil to be added from a filter pump as previously discussed and would allow for external filtering of the hydraulic reservoir oil if needed. Install a petcock valve on the front of the reservoir that will be used for consistent oil sampling.

Equipment and parts needed:

Quick disconnects that meet or exceed the flow rating of the Portable Filter Pump.

Pump.

Two gate valves with pipe nipples.

One 10 micron filter breather.

**WARNING:** Do not weld on a hydraulic reservoir to install the quick disconnects or air filter.

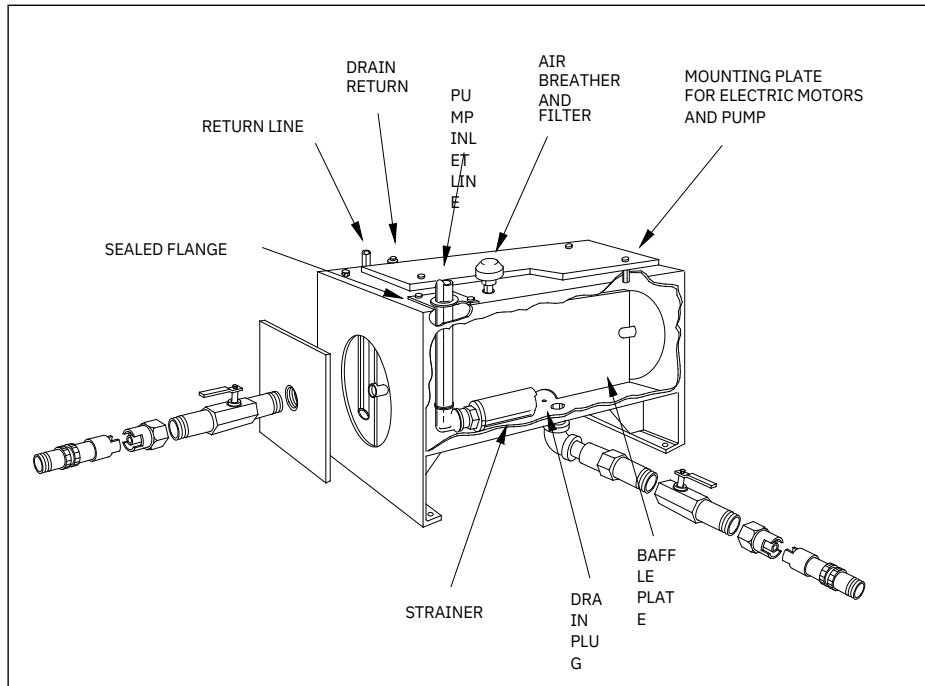

Figure 5. Hydraulic Reservoir Modification

=====

## Root Cause Failure Analysis

As in any proactive maintenance organization you must perform Root Cause Failure Analysis in order to eliminate future component failures. Most maintenance problems or failures will repeat themselves without someone identifying what caused the failure and proactively eliminate it. A preferred method is to inspect and analyze all component failures. Identify the following:

Component Name and model number.

Location of component at the time of failure.

Sequence or activity the system was operating at when the failure occurred.

What caused the failure?

How will the failure be prevented from happening again?

Failures are not caused by an unknown factor like “bad luck” or “it just happened” or “the manufacturer made a bad part”.

We have found most failures can be analyzed and prevention taken to prevent their reoccurrence. Establishing teams to review each failure can pay off in major ways.

To summarize, maintenance of a hydraulic system is the first line of defense to prevent component failure and thus improve equipment reliability. As spoken about earlier, discipline is the key to the success of any proactive maintenance program.

Article written by Ricky Smith based on his experience troubleshooting systems over 40 years.

If you like a copy of this article email me at [rsmith@worldclassmaintenance.org](mailto:rsmith@worldclassmaintenance.org)

### Join me for “Maintenance Technician Best Practices” Workshop “February 22-24, 2022”



- Live at Southern Wesleyan University (4 miles from Clemson, SC and 30 Minutes from GSP Airport)
- and Virtual via Zoom

The objective of the course is to align Maintenance Technicians with Maintenance and Reliability Leadership in “Known Best Maintenance and Repair Practices”. This alignment will bring down barriers most organizations face when trying to optimize asset reliability.

- To enhance communication between maintenance, reliability, production, and plant leadership and maintenance technicians.
- To provide the vision of proactive and maintenance to all maintenance technicians.
- To increase knowledge and skills for maintenance technicians through education and knowledge sharing.
- To define roles and responsibilities between technicians and managers.
- To reduce turnover of maintenance technicians because of lack of understanding between management and hourly technicians.
- ...and so much more

For information send request to [rsmith@worldclassmaintenance.org](mailto:rsmith@worldclassmaintenance.org)

# #1 Software for Maintenance & Reliability Teams

UpKeep is a service-first company that builds software designed to make maintenance easier for technicians and managers everywhere. Reduce downtime up to 18% by switching over to a preventative maintenance solution!

[www.upkeep.com](http://www.upkeep.com)

## Our Products



**Mobile-first maintenance management and collaboration across all location, assets, and teams**

With nearly 340 different machines in our work environment, it's an impossible task to manually assign and track PM's. **With UpKeep we can schedule regular maintenance without overlapping tasks with other critical jobs."**

★★★★★ Paul D, Health and Safety Coordinator

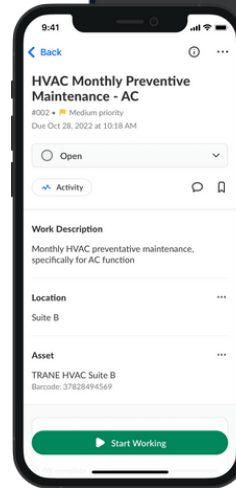
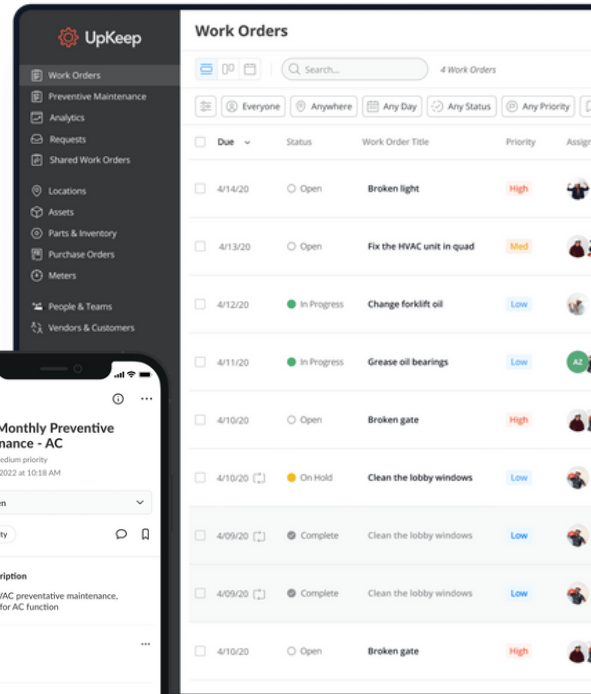

**An end-to-end solution for remote condition-based monitoring**

Connected and secure IoT sensors for real-time remote condition asset monitoring



**Integrated & Centralized Data Ecosystem for World Class Asset Operations**

The only purpose built Asset Data Platform. Asset Focused ELT Solution for advanced analytics and integrated, real-time asset data.

**The Maintenance Community Coalition was founded on the belief that working together will benefit everyone within our community**

Committed to helping each other thrive in our individual professional journeys by sharing resources and expertise, granting scholarships, hosting events, and unlocking knowledge – always at no cost.

