

**3500 SERIES**  
 1500 GALLON GREASE TRAP  
 SINGLE BAFFLE

General Notes: 1. Unit comes with interior piping installed.  
 2. Inflow section of unit must be filled with at least 14.5" of clear water prior to use.

Specifications: 1. Concrete has design strength of 5,000psi @ 28 days. 2. Steel reinforcement: ASTM A-615, grade 60 ASTM A-497 welded wire fabric. 3. Designed for H2O loading. 4. CI Casting: ASTM A-48, class 30/35.

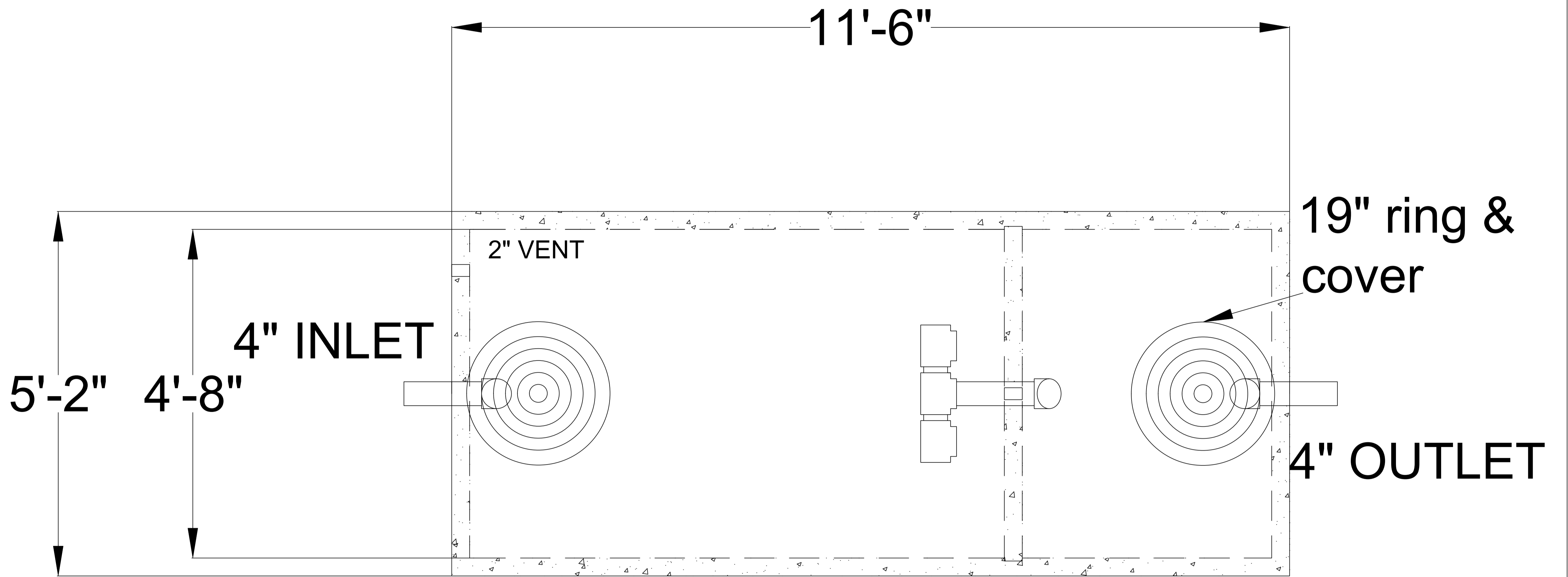

TOP VIEW

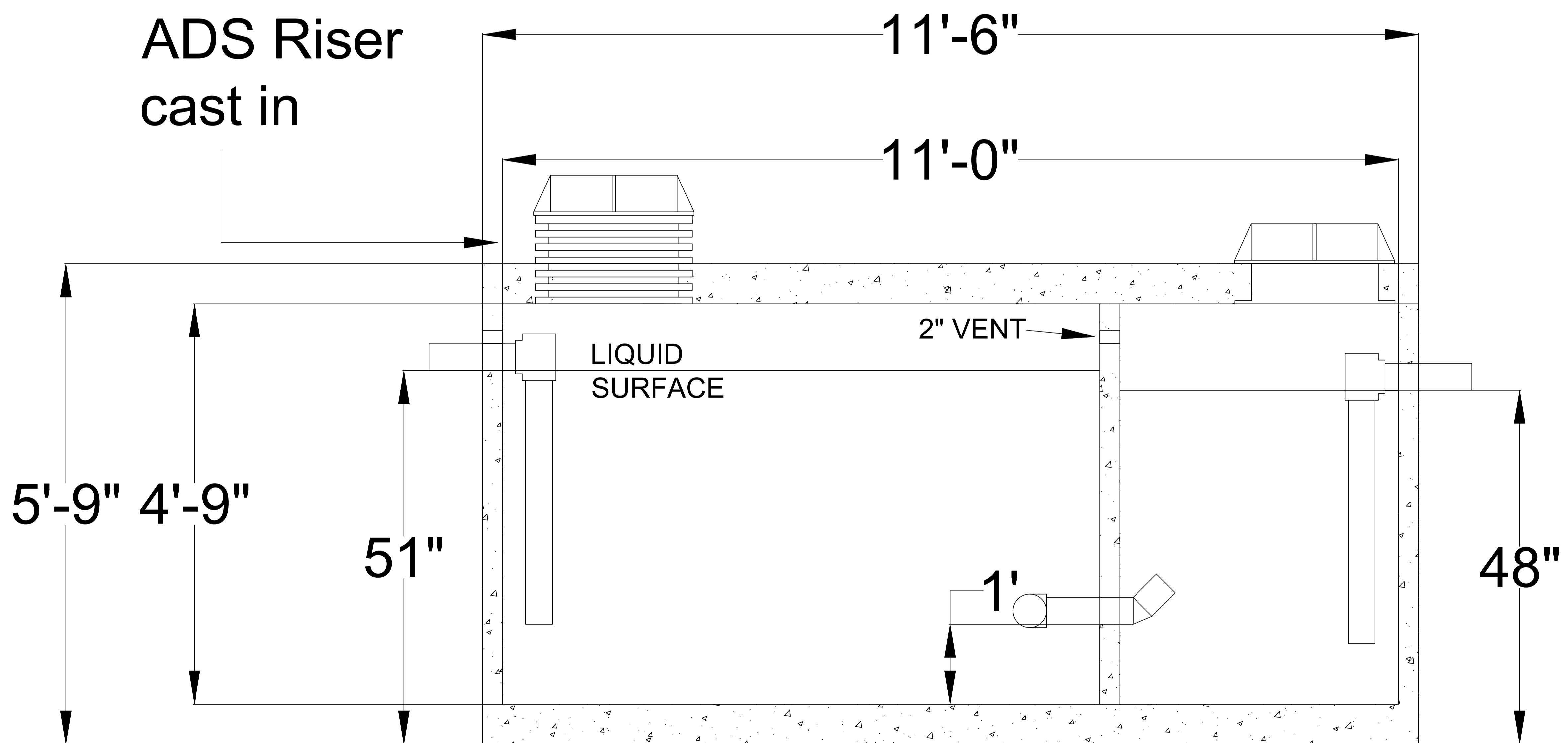

SIDE VIEW

1500galgtsb.dwg	APPROVED FOR PRODUCTION	AUTHORIZED BY
	DATE:	PRINT:
	FILE NAME:	JOB TITLE: