

## Contents

- (1) Slide Cabinet
- (6) Drawers
- (6) Drawer Knobs w/Screws
- (12) Foam Rubber Slide Stops
- (12) Label Inserts

**Base Unit** (sold separately) **MODEL #SC100B**

## Specifications

### Overall Dimensions

Inches W x H x D	15.75x4.88x18.75
(CM) W x H x D	40x12.40x47.60

### Weight (lbs)



Shipping 25.5 lbs	Stand Alone 22.5 lbs
-------------------	----------------------

### Colors

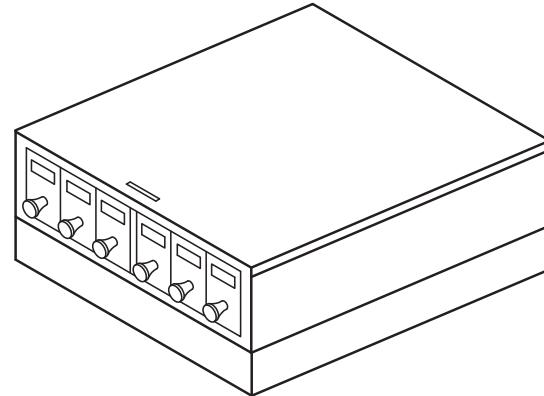
Standard Beige	Clean Room Ivory
----------------	------------------



**Slide Cabinet Shown on Base Unit**  
Shown assembled

-  **DO NOT stack Slide Cabinets more than 12 units high.**
-  **DO NOT use a Slide Cabinet without a proper base.**

## Construction

Made with durable 20-gauge steel, we build our Slide Cabinets with the strength to endure for the long haul. Then we finish them with a smooth, non-textured surface that we coat in a rust-resistant, easy-to-clean powder coat paint available in Standard Beige or Clean-Room Ivory: making specimen storage both beautiful and reliable.

## Receiving

- Carefully unpack all contents.
- Sort through all packing material to find the correct quantity of parts.
- Examine each component for damage sustained during shipment.
- Refer to the enclosed Damaged/Missing Item Report for any problems.

## Contact Us

### General Inquiries

1800-482-4328(HEAT)  
information@quincylab.com

### Technical Questions

773-622-2428 Option 2

Quincy Lab, Inc.  
109 Shore Dr., Burr Ridge, IL 60527

## Instructions

### Inserting Slide Stoppers

Each slide cabinet comes complete with (12) foam rubber slide stops. To install, simply compress or squeeze each foam rubber slide stop and insert in each drawer as shown. **(FIG. 1)**

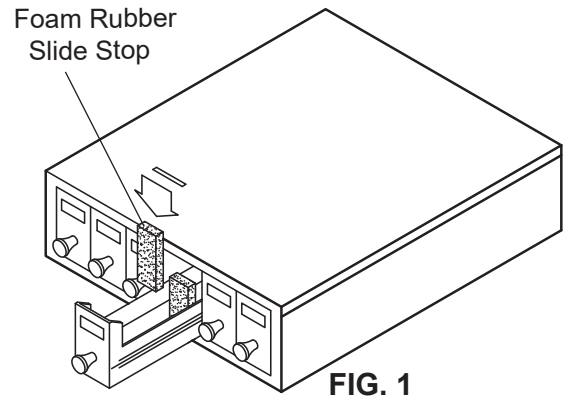

**FIG. 1**

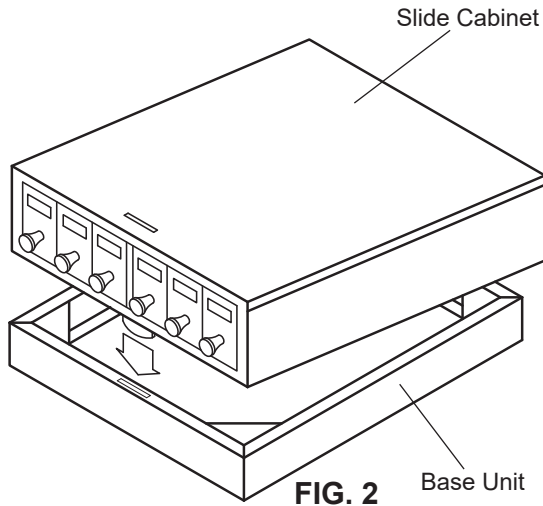

**FIG. 2**

### Placing Slide Cabinet on Base Unit

To place a Slide Cabinet on a Base Unit, first hook the rear tab into the rear slot, then lower the front tab into the front slot. **(FIG. 2)**

### Stacking Slide Cabinets

Slide cabinets are stackable. For multiple units, they can be stacked on top of each other by engaging the interlocking tabs found on the bottom of each cabinet, into the slots found on the rear and top of each cabinet. **(FIG. 3)**

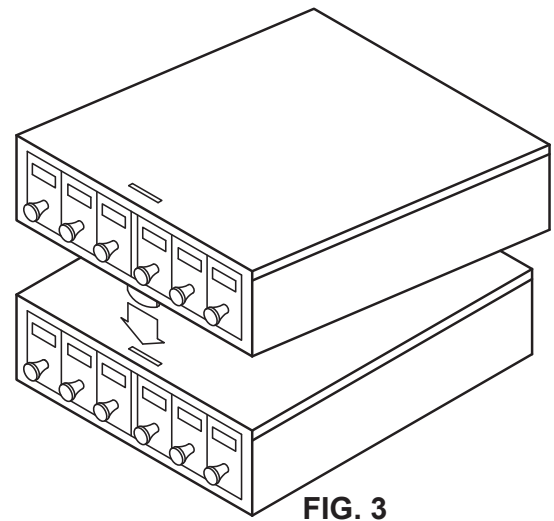

**FIG. 3**

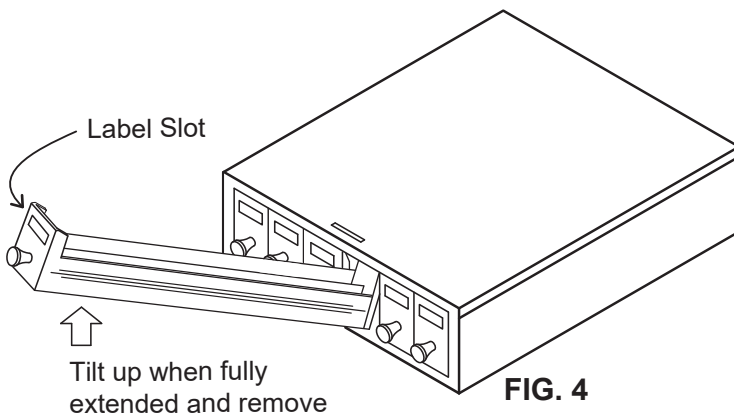

**FIG. 4**

### Removing Drawers & Labeling

Drawers have a safety stop to eliminate falling out when extended, however, they are easily removed for moving to a work station by simply tipping upward when fully extended as shown. **(FIG. 4)**

Convenient label slots located at the front of the drawers allow for easy insertion and removal of label inserts (supplied), which can be easily printed for content designation.