

Elevation

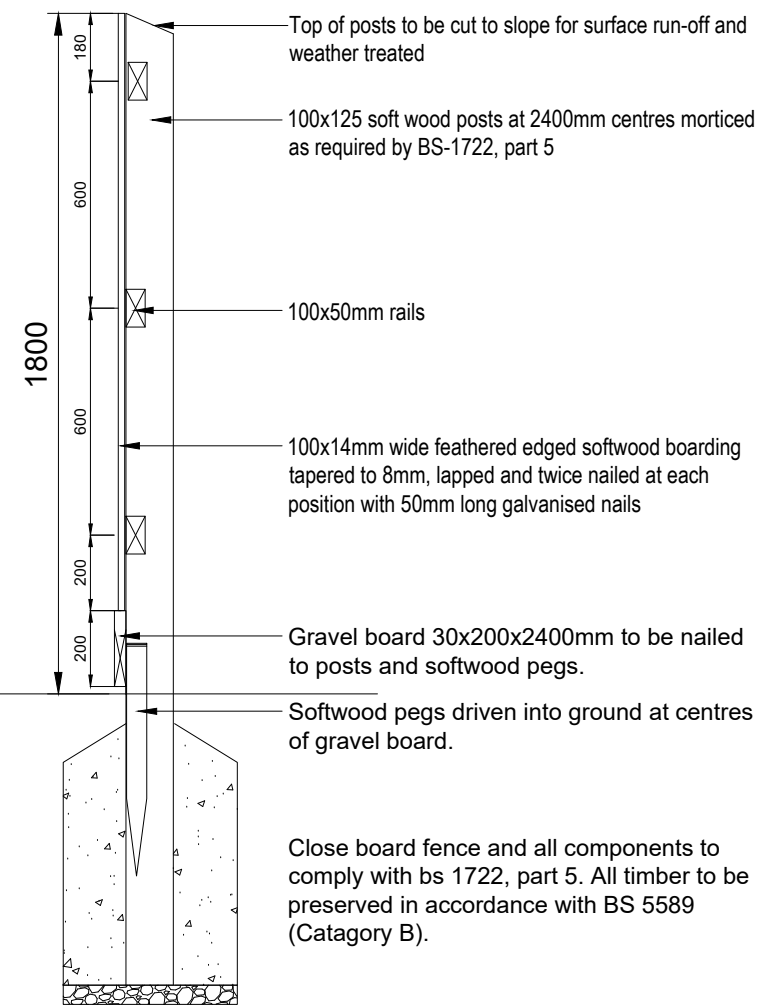

Section A-A

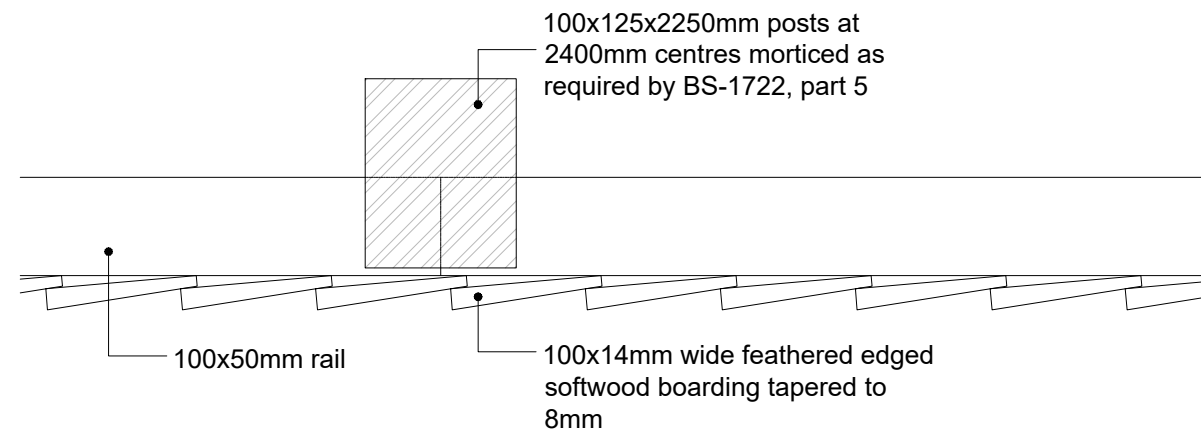

Section Detail

NOTES

Posts to be set in holes 300 x 300 x 600 or 800 or 750mm deep and bedded in weak concrete for half their depth below ground level, and remaining depth to be filled with rammed earth.

Posts should be weathered approx. 30 degrees from the horizontal leaving a flat approx. 38mm wide.

Boards should be minimum 100mm wide x 14mm to 8mm nailed to each rail and should lap 12mm min.

Nails: Galv. nails should be used throughout to avoid rust staining on the timber.

Posts to be softwood and to be pretreated with preservative.

Boarding to be softwood pretreated with preservative.

Posts and Fence in accordance with B.S. 1722 pt 5.

REV.	DESCRIPTION	DATE
------	-------------	------

CLIENT

Ateb Group

DRAWING TITLE

External Details

1800mm Timber Close Board Fence

SCALE	DATE	DRAWN BY
1:20/1:5@A3	Apr '23	HA Ltd

DRAWING NO.	REVISION	TYPE
2286-D04	.	PLN



10 Gold Tops
Newport
NP20 4PH
t. 01633 844970
e. info@hammond-ltd.co.uk

www.hammond-ltd.co.uk