

20023-03

Project

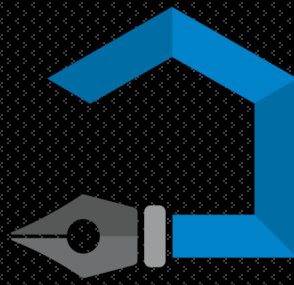

SIGNER
DESIGNER

... more than cabinets

6735 Conroy Rd. Unit 209. Orlando, FL. 32835
(407) 435-5380 • mdebarros@signerdesigner.com



Master Bathroom Remodeling

Client:
Miguel Muñoz
Miguelam3@gmail.com
13249 Oakensham Ln.
Orlando, FL. 32832

Made in Germany

**BEECK
KÜCHEN**

echt | ehrlich | einzigartig

www.signerdesignerllc.com

About our brand



*88 years
of experience and
quality*

One company!

One team!

A 4th generation family business, they work with highly qualified employees to develop and produce top-quality Made in Germany kitchen furniture with passion, creativity, and the highest standards of quality. Ultimately, they want people to be happy with our kitchens from the moment they set eyes on them, and for many years afterward – after all, cooking should be enjoyable.

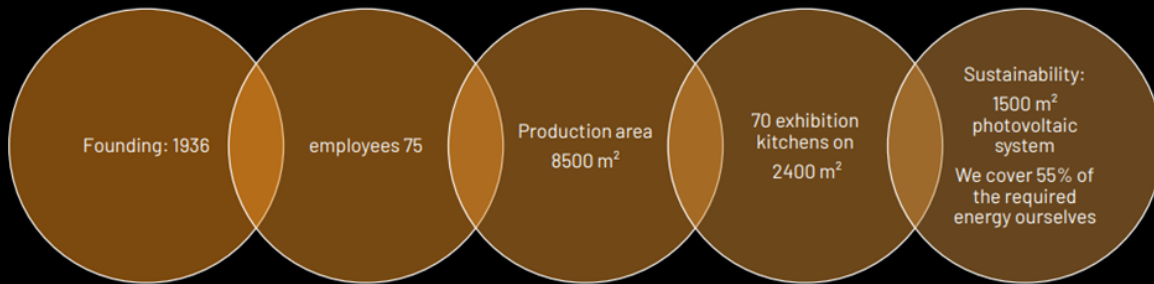

PEFC guarantees that wood and paper products come from only sustainably managed forests.

PEFC is the largest institution for ensuring and marketing sustainable forest management, through an independent certification system.



All cabinets comply with the high US standards CARB2 and TSCA Titlke 6.

Wood products made from CARB2 panels are sustainable, environmentally friendly and ensure a healthy indoor climate



Solidity perfected!
The quality of Beeck Küchen craftsmanship never fails to impress. Sides and bases are 19 mm thick and back walls 8 mm thick. This guarantees good durability and many years of enjoyment in a unique, high-quality kitchen.

Your kitchen design Please note that the images are a 3D reference



Your kitchen design Please note that the images are a 3D reference



Your kitchen design Please note that the images are a 3D reference



Your door style.

DOOR WITHOUT HANDLES

A simple front that functions as the ideal basis for any kitchen architecture.

The handleless kitchen is convincing in its clear, timeless design: uncompromising in quality, form and functionality.

The horizontal recessed grip as a small engagement in the carcass emphasizes the beauty of the simple line.

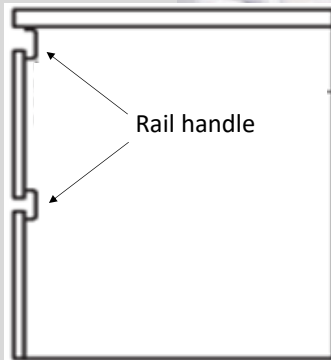

1100 Trend Uni.

Finish: 103 Melamine, Color: K 134 shadow
Melamine resin coated front, gloss, surrounding edge in same color



GRLSED swing stainless steel



Countertop
Finish: Chipboard 23/8".
Color: 711 Santa fe oak graubraun

Shelves:
Finish: Laminate. Color: K 019 Vintage oak

Countertop Sugges-



Silestone - Eternal
By Cosentino

Et Noir

Thicknesses: 1.2cm 2cm 3cm

You get more than a kitchen cabinet ... you get quality, engineering, invention and elegance

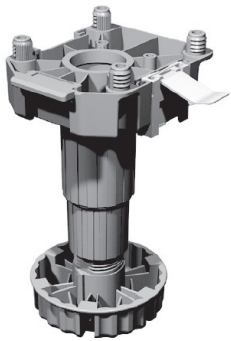

Base and tall units are supplied with height adjustable feet. The adjustment range from + 20 to - 10 mm guarantees millimetre accuracy. The plinth panel is protected against moisture by a sealing or U-profile.

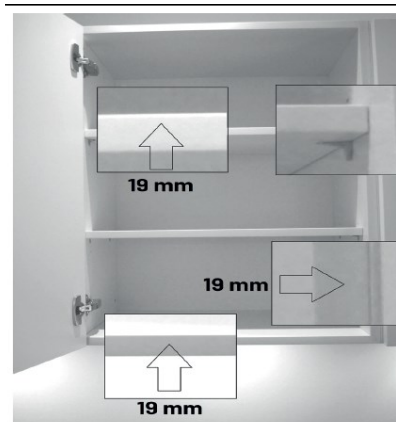

The carcass is made of a high-quality derived timber material board in 19 mm thickness. All wood-based materials used are made of sustainably cultivated PEFC-certified material that meets the new CARB2 standard. Only material coated on both sides with melamine is used in the carcass to prevent moisture from penetrating the wood-based material.

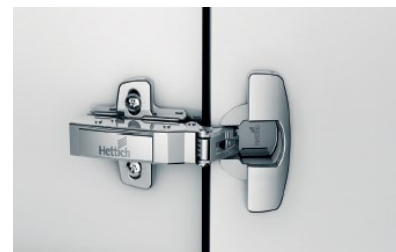

The carcass parts are glued permanently for stability with solid wood dowels.

The all-metal clip hinges used are self-closing and are mounted / dismantled by clipping them in / out without tools.

They are also equipped with integrated soft close.

The hinges are 3-dimensionally adjustable and have an opening angle of 110° or 165°.

The opening angle can be limited by optional limiters.

The front edge consists of 1.2 mm thick ABS edge. The safety edge is glued with PUR glue (polyurethane). The strong and thermally resistant connection between the edge and the wood material ensures optimum protection against the penetration of moisture.



The AvanTech system offers you a modern and straightforward design without sacrificing any storage. It is particularly impressive due to the following points:

- 13 mm narrow frame thickness without cover caps.
- A unique running comfort.
- 3-fold adjustment possibilities, which are not visibly integrated in the frame.
- Powder-coated metal frames in color Carbon.
- Upper cover profile in stainless steel look.
- Load capacity 40/70 Kg.
- Integrated pull-in soft close..



Cupboard suspension

Wall units are supplied with rear top and bottom recess to allow for ventilation,

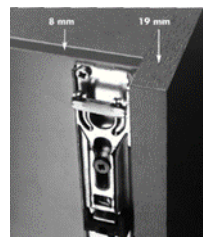

Cabinet details

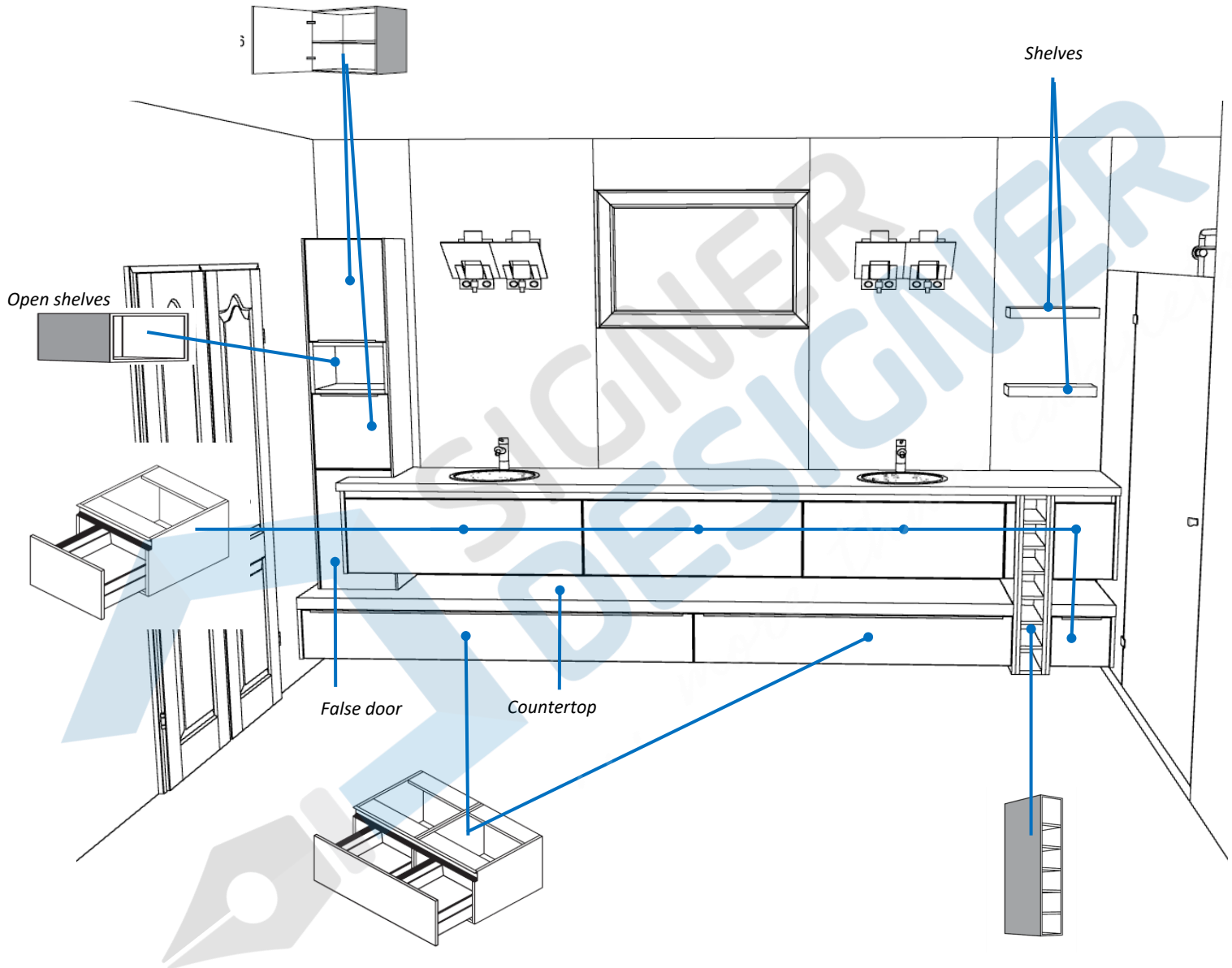

(L) door opening to the left, (R) door opening to the right

★ Possible changes in this cabinet, defined by the BEECK Technical department or depending on the appliance approved by the client

Your project includes the following accessories and system:



Multipurpose insert Anthracite

High resistance plastic in anthracite grey color. Included in **all** interior drawers.

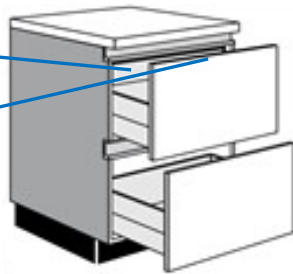

Driver Internal drawer

Connects the interior drawer with the external drawer and with a simple pressure it disconnects and gently slides back.

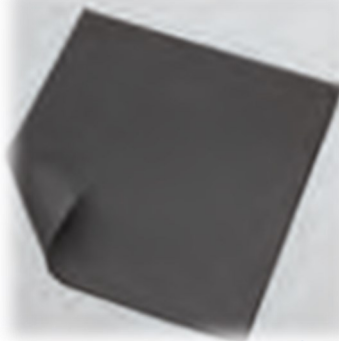
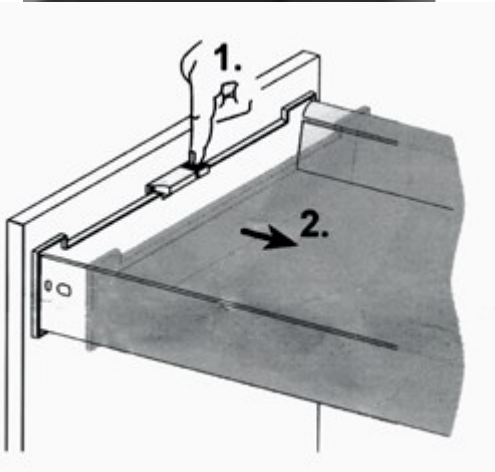

Matt

Anti-slip mat for all drawer In anthracite grey. Included in all drawers.

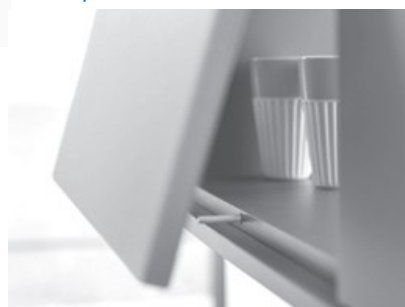

Door opening fitting



Designer: Maria De Barros
Document prepared by : Maria De Barros
Marketed and Imported by: Signer Designer LLC
Cabinets manufactured and assembled by: Beeck Kuechen GmbH
Installation by: Signer Designer LLC



Thank you for contacting us

... we are something more than a cabinet, we are technology, quality and perfection