

Above ground systems

SMART-Line | City-Line | Model C | Model B
Industry container | Gastro container



Overall solution from a single source

The product range of Villiger Entsorgungssysteme is broad and deep. So we are able to provide complete system solutions.

The under- and above ground waste collecting systems, as well as the matching fully automated crane system, a discharge unit and a mobile cleaning system do fully cover the needs of our clients. Good to know: All our products are compatible with conventional crane systems.

Flexibility is our strength:

- Planning
- Consulting & Sales
- Engineering
- Manufacturing
- Assembly
- Service & Maintenance
- Repair
- Retrofitting
- Customisation
- Spare parts stock

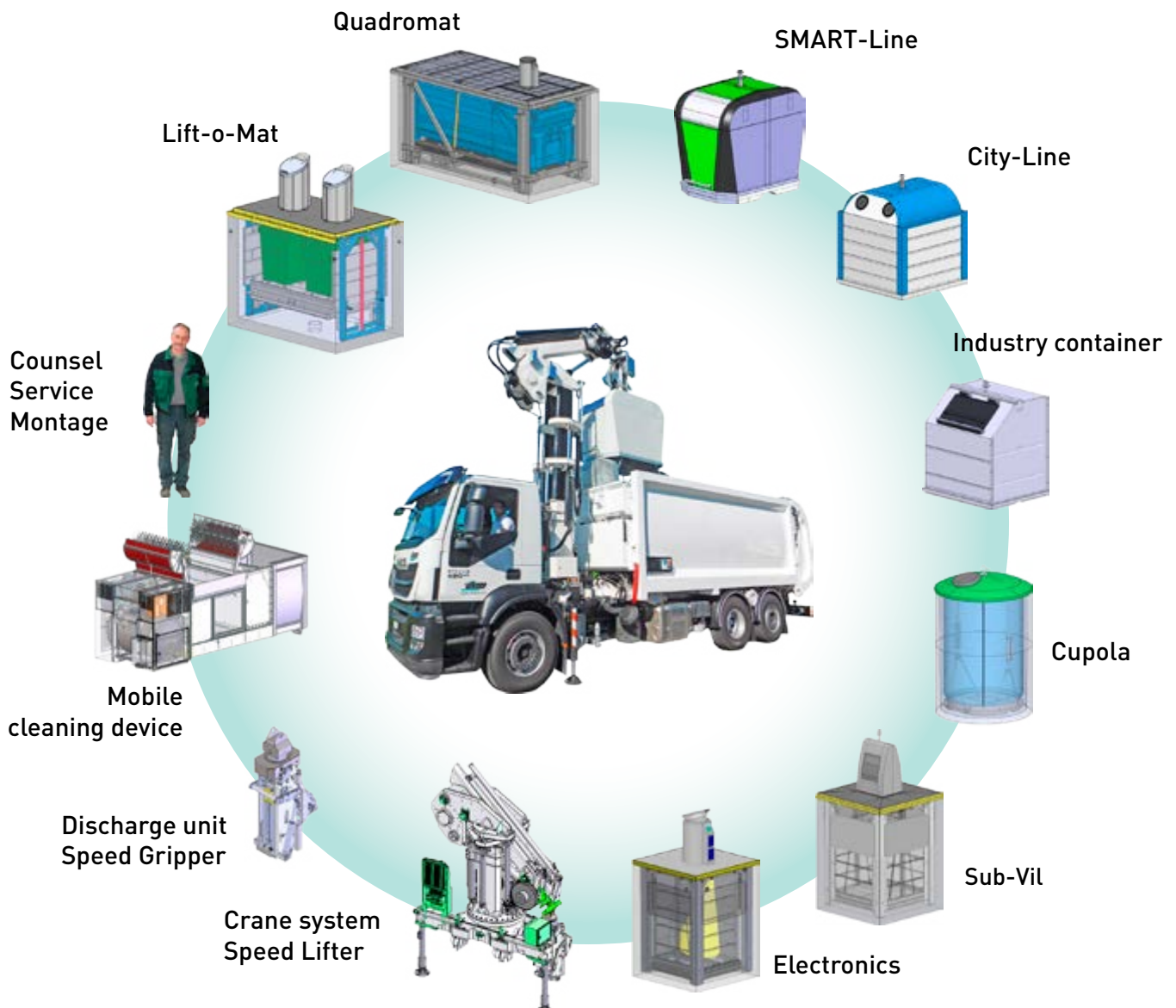

Table of contents

| | |
|--------------------|----|
| SMART-Line | 04 |
| City-Line | 10 |
| Model C | 16 |
| Industry container | 19 |
| Model B | 21 |
| Gastro container | 22 |
| Emptying systems | 23 |



SMART-Line

For a well-groomed cityscape!



There is no reason to hide it: The new SMART-Line, an elegant and effective design. A harmonious form and elegant design for a very well-groomed cityscape.



An intelligent solution, made for you, with a mature technology, that you can rely on. In addition to the very high operator convenience, the new SMART-Line includes an ideal insertion height for a faster and more convenient disposal.



The new SMART-Line Family is fast, reliable and extremely comfortable in use, without any effort.





SMART-Line Container

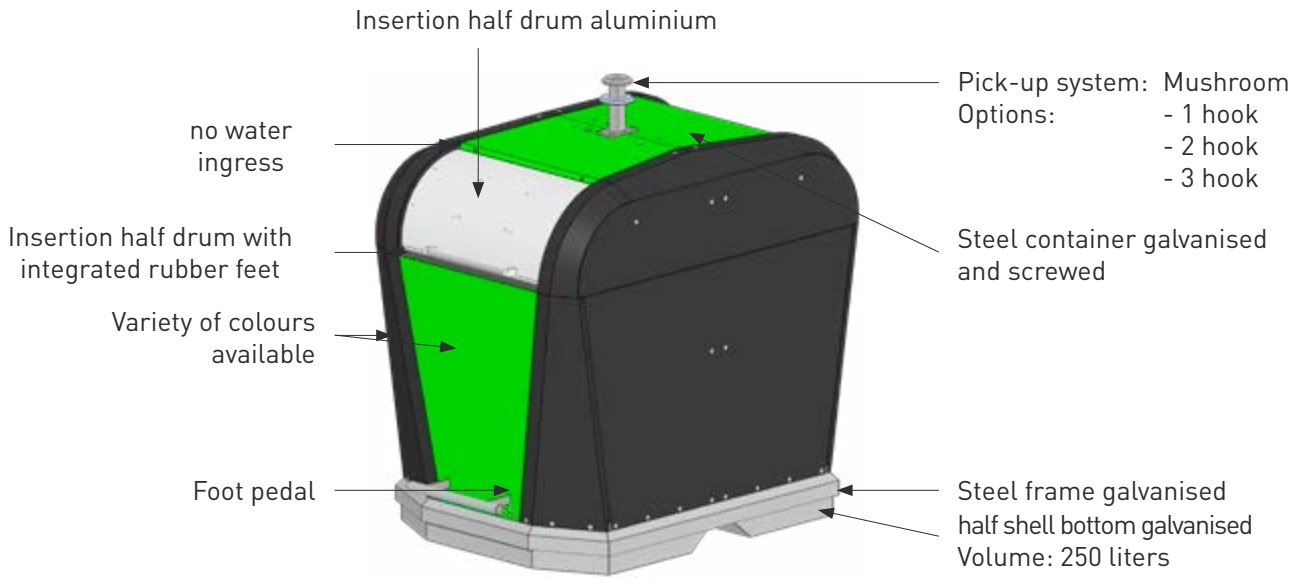

SMART-Line SL 120

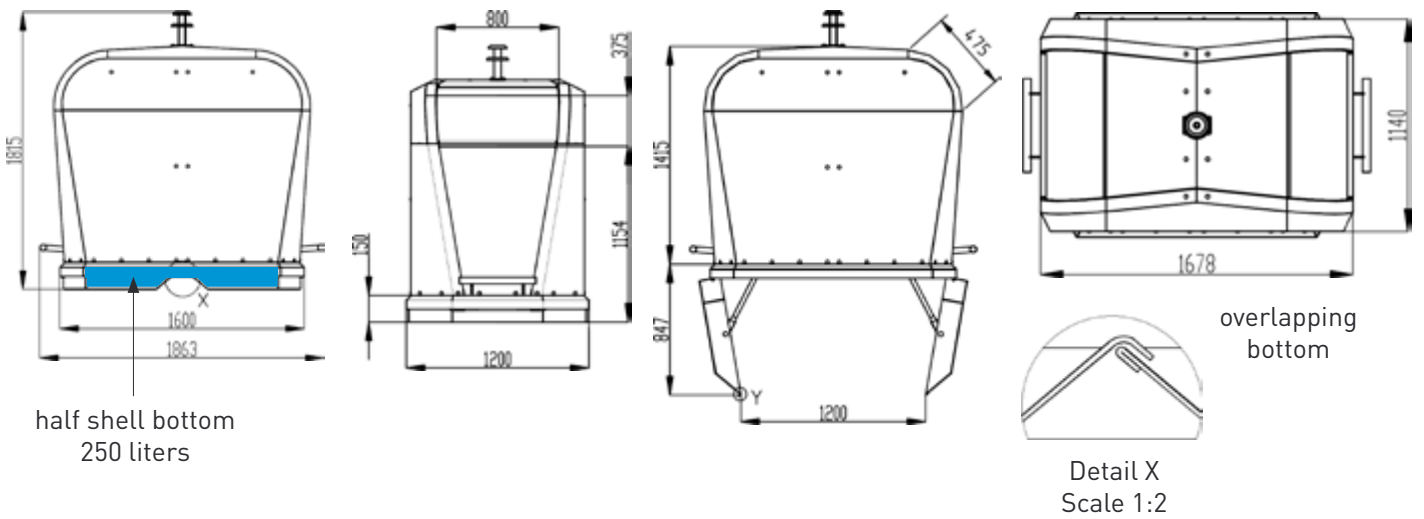
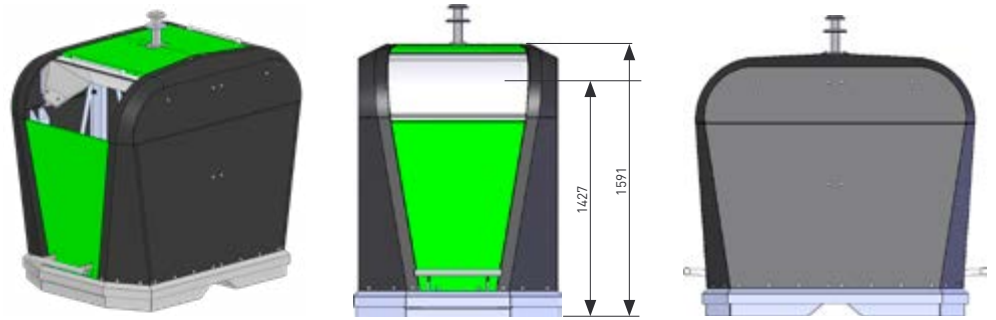

Centring rail



SMART-Line SL 100

Content: 2.5m³ | Dead weight: 250kg | Filling weight: 950 kg | Content half shell bottom: 210l

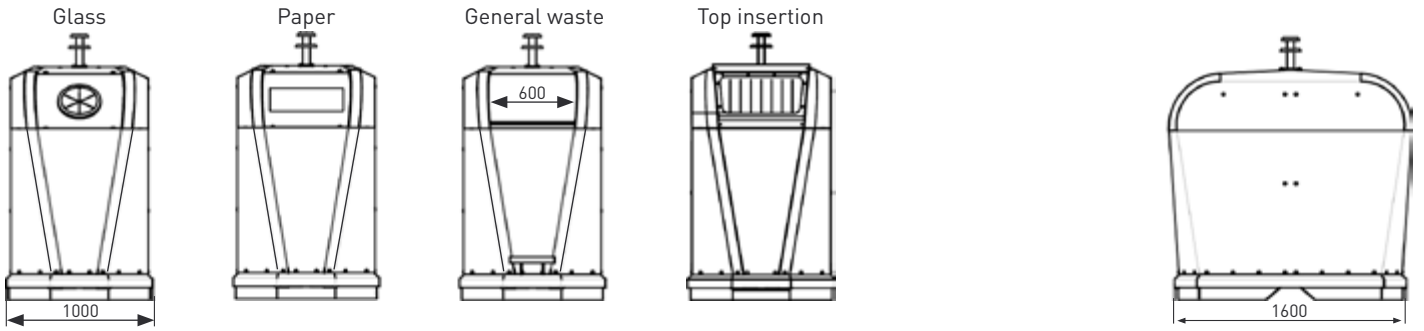

SMART-Line SL 120

Content: 3m³ | Dead weight: 270kg | Filling weight: 1050kg | Content half shell bottom: 250l

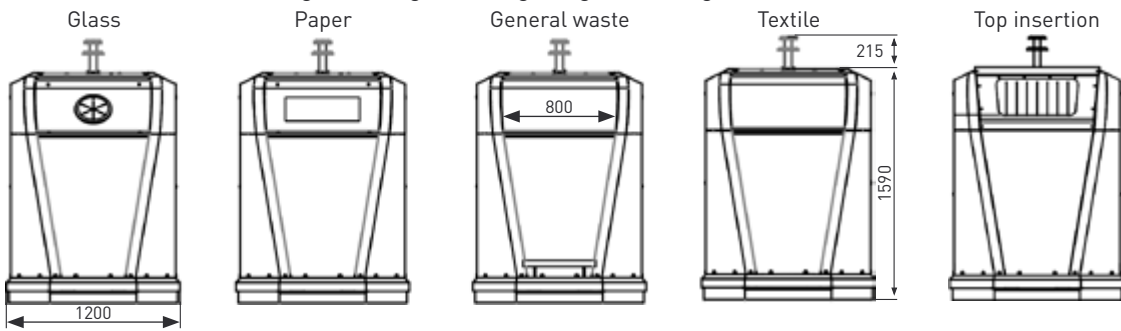

SMART-Line SL 150

Content: 3.8m³ | Dead weight: 310kg | Filling weight: 1200kg | Content half shell bottom: 320l

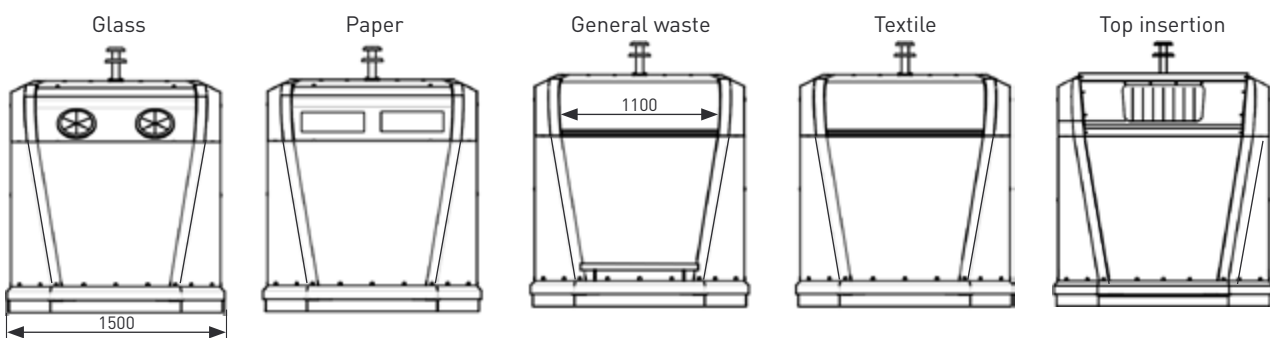

SMART-Line SL 180

Content: 4.6m³ | Dead weight: 360kg | Filling weight: 1300kg | Content half shell bottom: 400l

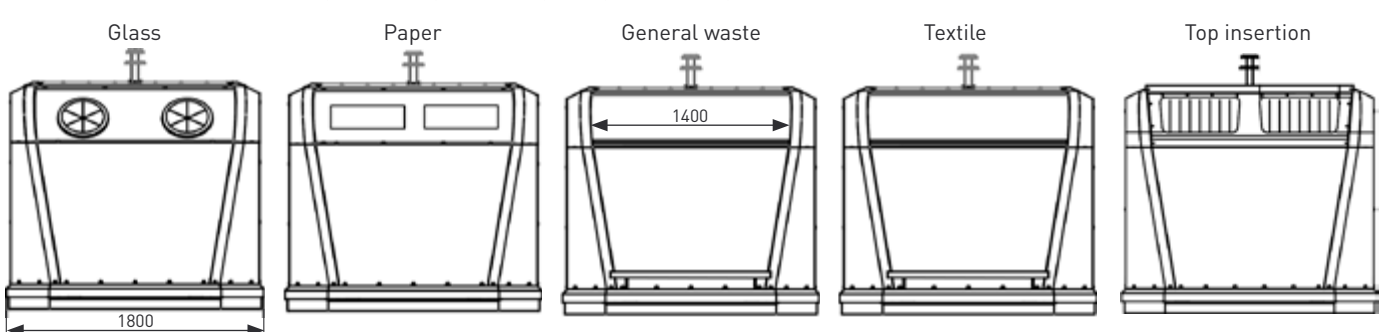



SMART-Line 1212



Dimensions and volumes

SL1212
2.2m³

Side view

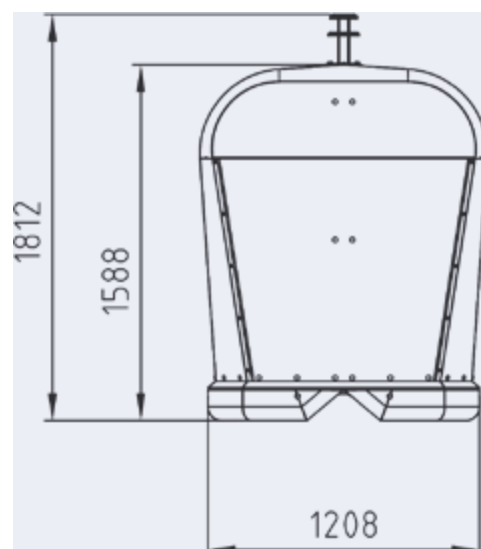
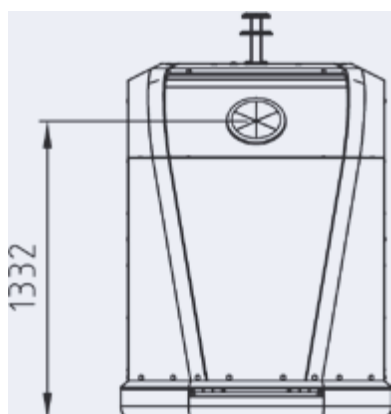



SMART-Bin

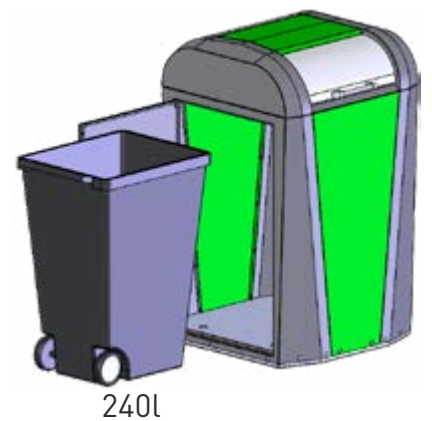
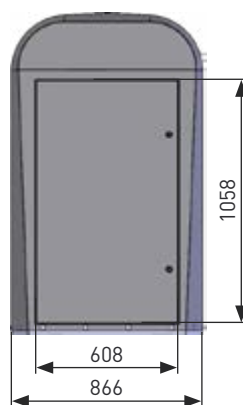
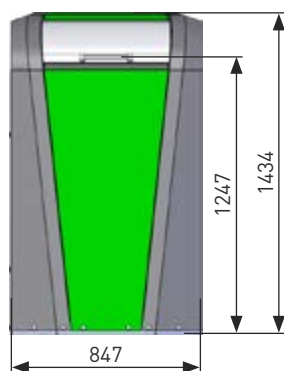

City-Line

The classic



The City-Line Container has a modern design and we use high quality materials. The City-Line container is suitable for collecting: Paper, Glass, Oil, PET, Cans, Textiles and Waste

Aesthetic and individual design

- 230 RAL Colours available
- We assist you in the planning and we offer many design solutions

Clean collection points

- Collecting Volume: 1.5 to 4.5 m³
- No rust because of galvanized steel parts

Resistance

- No risk of fire for housing estates and other containers
- Damages are repairable in a modular system



CI 120 container for glass



CI 150 container for glass



CI 150 container for cans with press

Noise protection

- Anti-Poster-creasing and powder coating
- Low maintenance cost
- Replaceable parts"

Bonded sheet metal

- Three layer bonded sheet metal;
- Sandwich Steel-Plastic noise insulation
- Steel

Material Insulation Class

- Three different noise protection-classes are available class 1-3, no loss of the useable volume.

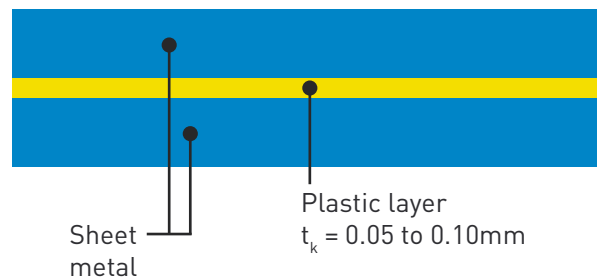

Material choice

- Galvanized steel parts
- Long life cycle thanks to galvanized steel
- Very resistant thanks to powder paintwork as standard

Roof Pipe as Edge Protection

Insertion pipe with flap





CI 150 container



CI 120 M multiuse container



CI 120 DR City-Tex with insertion flap for 60l bags



CI 180 DR paper / carton



CI 150 oil container



CI 150 oil container
Pull-out ramp for the removal of the barrels (2 pieces 200 l)
collecting pan ca. 450l



Details



Centring rail



Battery insertion



Battery collecting bag, content 10L, with emptying door



CI 150 DR ready to deliver (Morocco)



CI 180 DR glass container with shell bottom for a manual locking type UE 12



Dimensions and volumes

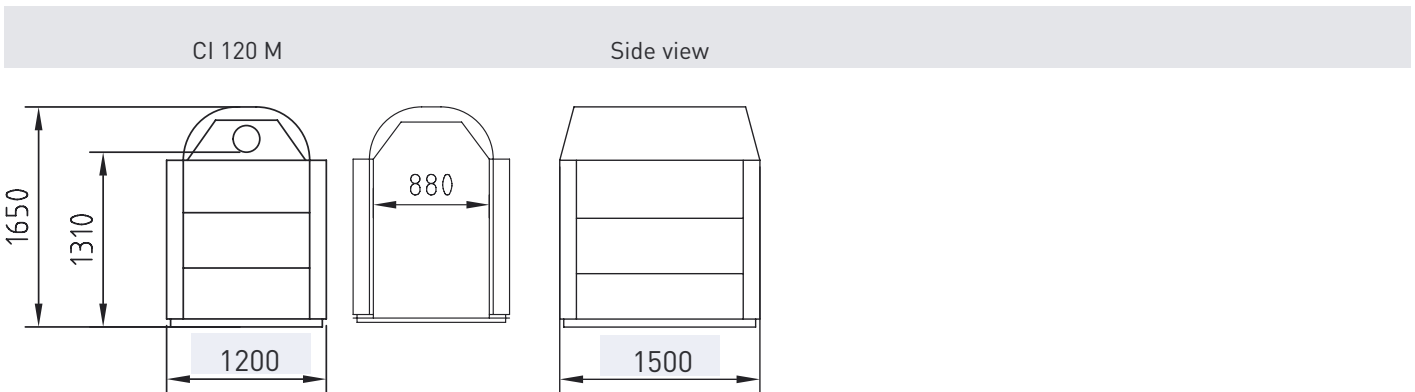
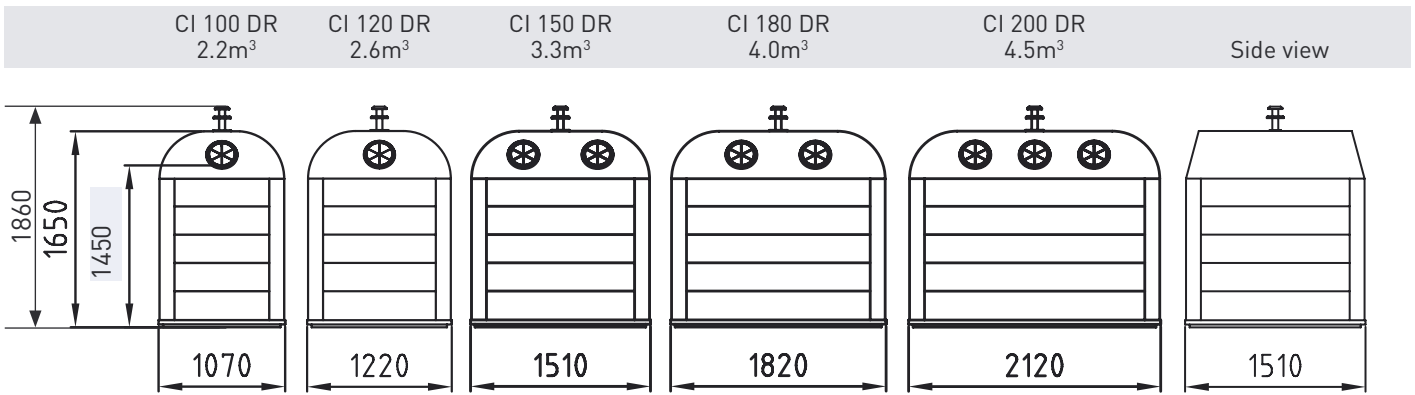
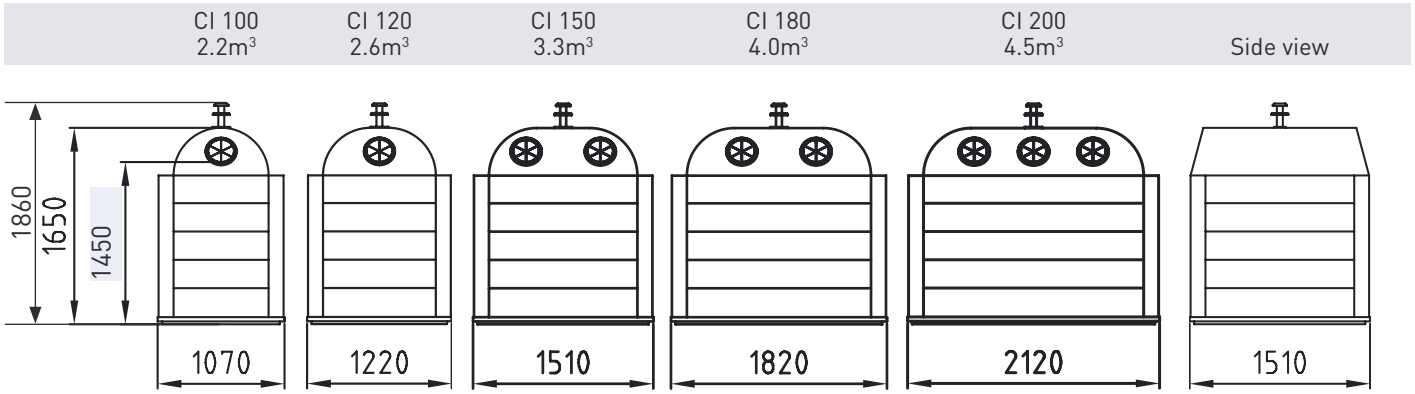

C-Model

The pioneer



A container system that ideally connects the requirements of inhabitants of the municipality with the demand of the waste management companies.

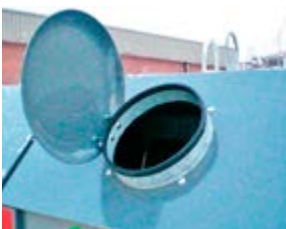

Perfection as requirement

Glass container may be equipped with noise protection if desired. All commercial emptying systems are available. Emptying without difficulty thanks to half-shell bottom.



C 150 F oil container
with 2 barrels of 200 l



Fold-out ramp, collection pan of ca. 450l
Big insertion to pour the oil



Dimensions and volumes

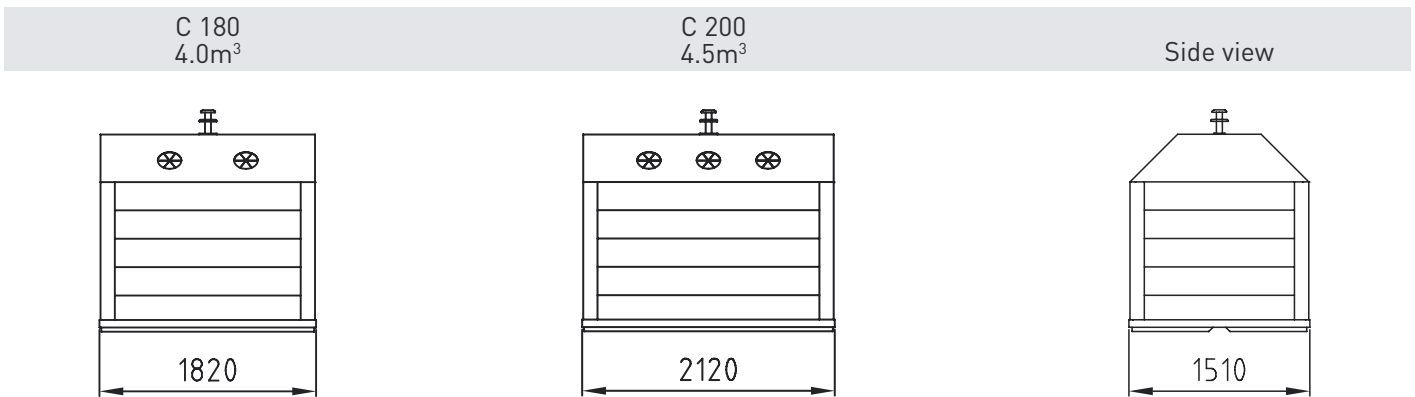
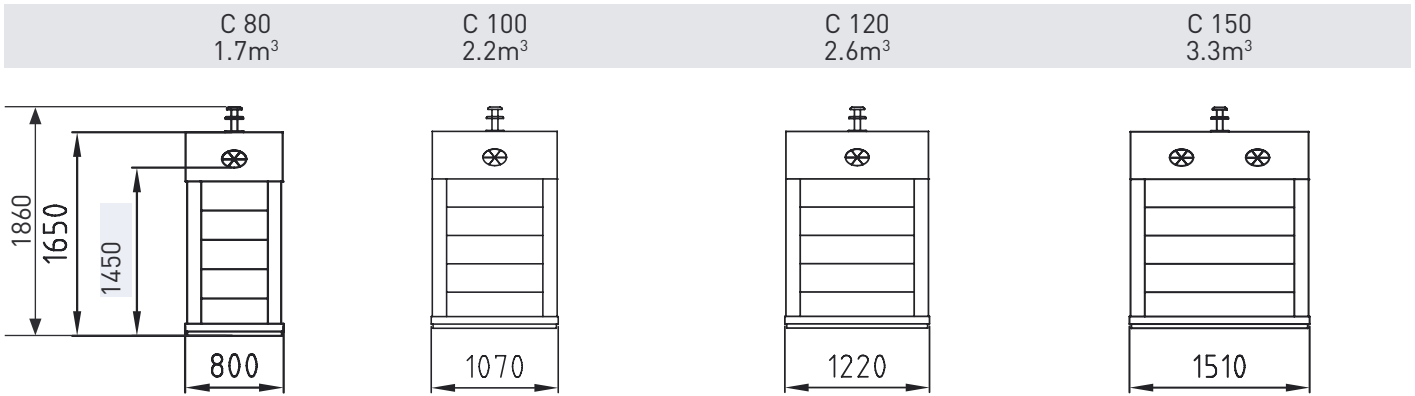

Industry container

The flexible system for large filling volumes



Clean collection points

Nowadays in industry and business there accumulate plenty of recyclable materials. Those materials may be sorted professional in our mobile industry containers.

For industry and business

Product specific wastes such as: Paper, Glass, Carton, Plastic, Waste, building site can be collected this container system

For construction and handcraft

Waste of renovations, construction waste





ID 48 container



ID 30 with trolley



locking

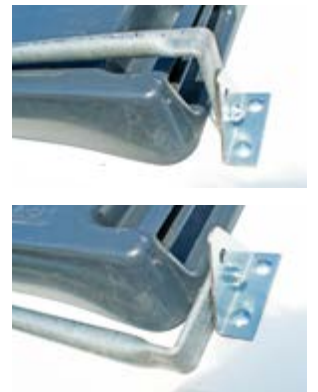

Dimensions and volumes

ID 25
2.5m³

ID 30
3.0m³

Side view

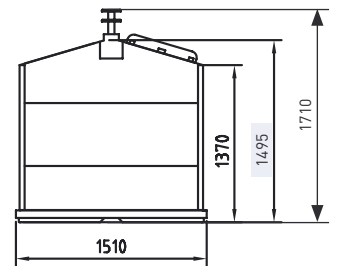
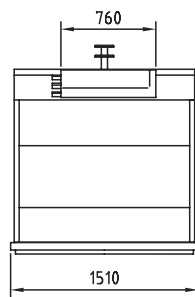
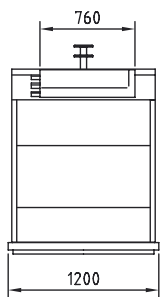

ID 48
4.8m³

Side view

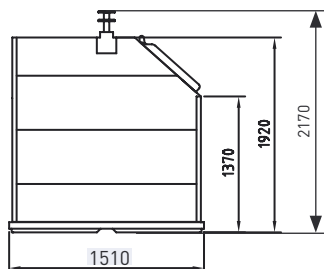
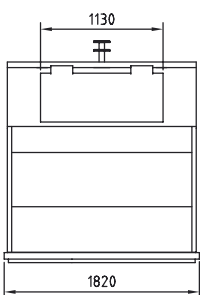

Model B

The economical solution



B-120
2.5m³



B-150
3.6m³



B-180
5.5m³

Dimensions and volumes

B-120
3m³

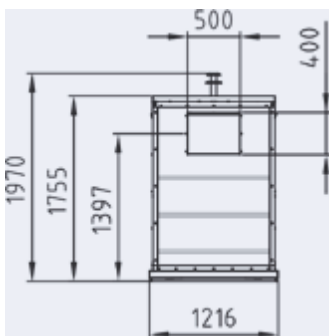

B-150
3.6m³

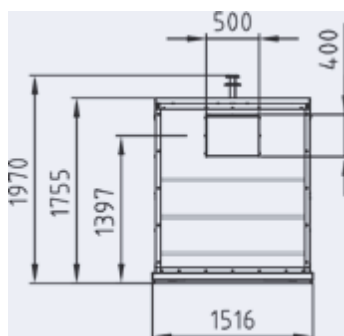

B-180
4.5m³

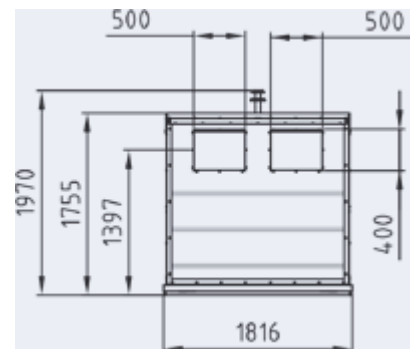

side view



Gastro container

Simplify the life of the innkeeper



The 1.5 m³ glass container is equipped with a shell bottom for excess liquids up to ca. 80l. The position of the container is freely eligible after each emptying thanks to the swivel rollers.

Glass insertion
insertion \varnothing 240mm

Insertion flap
insertion 375 x 375 mm



Dimensions and volumes

ID 10 Gastro
1.0m³

Side view

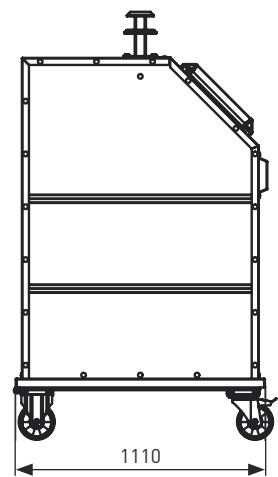
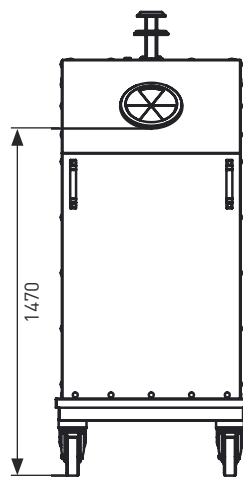
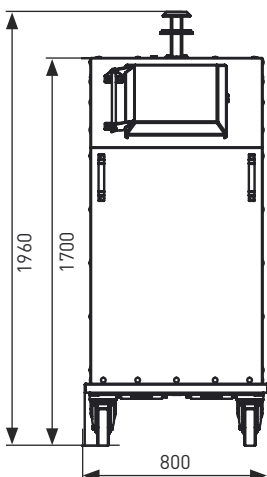

Emptying systems



Mushroom



1 hook



2 hook



3 hook

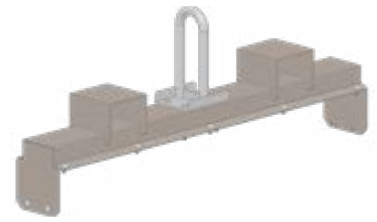

Forklift pick up system

| Container | Mushroom | 1 hook | 2 hook | 3 hook | Forklift pick up system* |
|--------------------|----------|--------|--------|--------|--------------------------|
| SMART-Line | x | x | x | x | x |
| SMART-Line 1212 | x | - | - | - | - |
| SMART-Bin | - | - | - | - | - |
| City-Line | x | x | x | x | x |
| Model C | x | x | x | x | x |
| Industry container | x | x | x | x | x |
| Model B | x | - | x | - | - |
| Gastro container | x | x | x | - | - |

*available from size 150

Manual locking

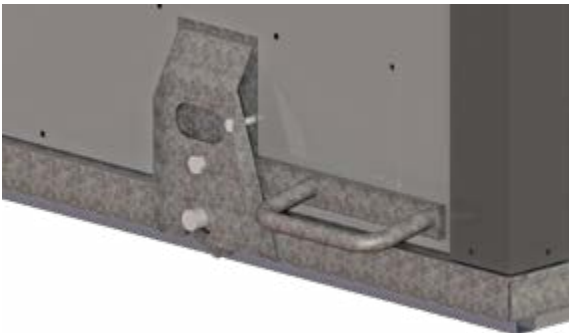

Type UE 12

Shell bottom

The shell bottoms may be ordered in 2 versions.

For waste as paper, residual waste etc. the standard shell bottom is ideal.

For organic waste (acc. to experience there is more liquid in it) the organic waste shell bottom with the bigger capacity is suited better. This makes the container 10cm higher.



Capacity: ca. 200 l



Villiger North America Distributors:

WasteTech

1838 Second Avenue, New York, NY 10128
www.WasteTech.US



The future of waste disposal systems

Villiger Entsorgungssysteme AG

Bahnhofstrasse 13

CH-5647 Oberrüti

Tel.: +41 41 784 23 23

Fax: +41 41 784 23 33

info@villiger.com

www.villiger.com