

***ViaLiteHD***  
**Fibre Optic Link System**  
**1U chassis**

User Manual

HRK1-HB-7

CR4565

17/09/2020



## Instrument Care and Safety Information

Please read the whole of this section before using your **ViaLiteHD** product. It contains important safety information and will enable you to get the most from your Fibre Optic link.

### Electrical Safety

The **ViaLiteHD** chassis provides the termination for power inputs and can be fitted with power supplies.



The **ViaLiteHD** chassis is a Safety Class 1 product (having metal chassis directly connected to earth via the power supply cable).

NOTE: Before removing ANY of the POWER SUPPLIES the power to that position MUST be ISOLATED (i.e. AC power is not applied to its inlet connectors). **ViaLite Communications** ships all units fitted with a single power supply with a blanking plug in the unused AC inlet, to prevent power being applied to that position; the HPS-1-0 blanking plug must not be removed unless a power supply is fitted.

When operating the equipment note the following precautions:

- Hazardous voltages exist within the equipment.
- There are no user serviceable parts inside; the covers MUST NOT be removed.
- There are no user replaceable fuses in the chassis mounted equipment. Replacement should only be carried out by a **ViaLite Communications** technician.
- The chassis earth stud SHOULD be connected to the safety earth.
- When using a 2 pin power supply cable the chassis earth stud MUST be connected to the safety earth.
- The **ViaLiteHD** Power Supply Modules do not have an isolating switch on the mains voltage inlet. For this reason, the **ViaLiteHD** chassis MUST be installed within easy reach of a clearly labelled dual pole mains isolation switch, which supplies the equipment.
- PSU modules fused on one input feed (see section 5), should be externally fused on both inputs if the polarity of the connectors could be reversed; rating should match those given in section 5.3.

### ESD Precautions

The **ViaLiteHD** 1U chassis is equipped with active electronics and will be fitted with additional active modules while in use.



Precautions for handling electro-static sensitive devices should be observed when handling all **ViaLiteHD** modules. Technicians should ensure that they use effective personal grounding (i.e. ESD wrist strap etc.) when servicing the equipment. Any equipment or tools used should be grounded to prevent static charge build-up. Good practice should be observed at all times. For reference see relevant standards. EN 61340-5-1, "Protection of Electronic Devices from Electrostatic Phenomena – General Requirements"

### Optical Safety

The **ViaLiteHD** chassis is not equipped with optical units but it may be fitted with them



The **ViaLiteHD** RF Transmitter and Transceiver modules contain laser diode sources operating at nominal wavelengths of 1270nm to 1610nm.

These devices are rated as EN60825-1:2007 CLASS 1 radiation emitting devices. A class 1 laser is safe under all conditions of normal use.

When operating the equipment note the following precautions:

- Never look into the end of an optical fibre directly or by reflection either with the naked eye or through an optical instrument.
- Never leave equipment with radiating bare fibres – always cap the connectors.
- Do not remove equipment external covers when operating.

### Hot surface

The **ViaLiteHD** Redundancy load module may have hot surfaces when operating under full load. The hot surfaces are not accessible when fitted in an approved chassis installation.



Suitable precaution should be taken when handling this device.

- Allow to cool for 10 minutes
- Do not touch metallic surfaces or printed circuit board when hot.
- When handling, hold front panel and handle only.

## TABLE OF CONTENTS

1	INITIAL INSPECTION .....	4
2	INTRODUCTION TO THE <i>VIALITEHD</i> RANGE .....	4
3	<i>VIALITEHD</i> AND <i>VIALITE CLASSIC</i> COMPATIBILITY .....	5
4	<i>VIALITEHD</i> SYSTEM COMPONENTS .....	6
4.1	<i>ViaLiteHD</i> 19" Chassis .....	6
4.2	Description .....	6
4.3	Power Interface Management .....	7
4.3.1	External backplane power .....	7
4.3.2	Module bias feed .....	7
4.4	Alarm Management .....	7
4.4.1	Common Chassis 25way Connector J1 .....	7
4.4.2	Connecting to an "open collector" output .....	7
4.4.3	Summary Alarm .....	7
4.4.4	Module Alarm Defeat .....	8
4.4.5	Using open collector alarms with controller cards .....	8
4.4.6	Using open collector alarms with RF switch and RF splitter cards .....	8
4.5	Heat management .....	8
4.6	Unused module positions .....	8
4.7	Minimum power supply load .....	9
4.8	Chassis Specification .....	9
4.9	Chassis connector pinouts .....	10
4.10	LNA feed and BUC feed pin assignment for different module types .....	11
5	<i>VIALITEHD</i> POWER SUPPLIES .....	13
5.1	Slide in Chassis AC Power Supplies, HPS-1 .....	13
5.2	Slide in Chassis DC Power Supplies, HPS-1-DC .....	14
5.2.1	Fuse replacement in DC Power Supplies .....	15
5.3	Specification .....	16
5.4	19" Chassis Power Requirements .....	16
6	INSTALLATION GUIDE .....	17
6.1	Chassis Installation .....	17
6.2	Power Supply Module Installation (slots 4 and 5) .....	17
6.3	5HP Standard Plug-in Modules (slots 1-2 HRK1C, slots 1-3 HRK1S) .....	17
6.4	5HP Blind-mate Plug-in Modules (slots 1-2 HRK1C, slots 1-3 HRK1S) .....	18
6.5	7HP Standard Plug-in Modules (slots 3 HRK1C) .....	19
6.6	5HP blanking panel installation (slots 1-2 HRK1C, slots 1-3 HRK1S) .....	20
6.7	7HP blanking panel installation (slots 3 HRK1C) .....	21
6.8	Power supply blanking panel installation (slots 4, 5) .....	21
6.9	Separate blindmate panels .....	21
6.10	Electrical power connection .....	21
6.11	Typical redundancy configurations .....	22
6.11.1	One 1:1 redundant transmitter, standard modules .....	22
6.11.2	One 1:1 redundant transmitter, blindmate modules .....	23
6.11.3	One 1:1 redundant receiver, standard modules .....	23
6.11.4	One 1:1 redundant receiver, blindmate modules .....	23
6.11.5	One 1:1 redundant link, blindmate modules .....	23
6.11.6	One 1:1 redundant link, plus two non-redundant links using dual blindmate modules .....	24
7	PART NUMBERING .....	25
7.1	<i>ViaLiteHD</i> Chassis, part numbering .....	25
7.2	<i>ViaLiteHD</i> Power supply, part numbering .....	25
8	MAINTENANCE AND FAULT-FINDING GUIDE .....	26
9	PRODUCT WARRANTY .....	27
10	FCC APPROVAL .....	27

## 1 Initial Inspection

Unpack and inspect the equipment as soon as possible. If there is any sign of damage or any parts missing, do not install the equipment before seeking advice from **ViaLite Communications** or your local agent.

The equipment received should match the delivery note that is shipped with the equipment. If there are any discrepancies, contact **ViaLite Communications** or your local agent.

Check that ALL unfitted POWER SUPPLY positions are ISOLATED (i.e. AC power is not applied to its inlet connectors). **ViaLite Communications** ships all chassis fitted with a single power supply, with a blanking plug in the unused AC inlet; to prevent power being applied to that position the HPS-1-0 blanking plug must NOT be removed unless a power supply is fitted. Failure to do this will cause a potential electrical hazard.

## 2 Introduction to the ViaLiteHD Range

The **ViaLiteHD** range has been developed to provide a modular solution to the transmission of a wide range of analogue and digital data where traditional 'copper wire' systems cannot be used, for example, in electrically noisy environments or over long distances

The range is ideal for permanent and semi-permanent installation in satellite communications, GPS, antenna remoting and other related applications.

The variety of links available includes low frequency timing (2kHz) to C-Band RF (7.5GHz), RF splitters, amplifiers and RF switches; they also include a full suite of supporting functions including RS232/422/485, Ethernet and control systems to monitor and control the system with both Web and SNMP interfaces.

All **ViaLiteHD** equipment operates over high quality glass fibre optic cable, which can be supplied in low-cost 3mm jacket, riser and outdoor specifications. The links can also be used with existing cable systems at customer premises.

A **ViaLiteHD** system can be added to at any time, enabling the system to evolve with the needs of the user.

**ViaLiteHD** is a product brand manufactured by Pulse Power and Measurement Ltd (PPM). **ViaLite Communications** is a division of Pulse Power and Measurement Ltd (PPM).

### 3 **ViaLiteHD and ViaLite Classic compatibility**

The RF and optical interfaces of most **ViaLiteHD** and **ViaLite Classic** modules are compatible. However the physical size, mounting systems and control of the modules are different, so it will not be possible to fit **ViaLiteHD** module in a **ViaLite Classic** chassis or housing and vice versa. However it is possible for modules of different types to interwork and be used to expand existing systems. Listed below is a brief summary of inter family compatibility.

- RF                      Compatible optical and RF interfaces
- RF + digital        Compatible optical and RF interfaces
- RS232                Compatible optical and digital interfaces
- RS422                Compatible optical and digital interfaces
- RS485                Compatible optical and digital interfaces
- Ethernet            Modules of matching speed have compatible optical and digital interfaces
- Protection Switch   Compatible RF interfaces may need interface cable (no optical interface)
- RF Splitters        Compatible RF interfaces (no optical interface)
- Amplifier            Compatible RF interfaces (no optical interface)
- Diplexer            Compatible RF interfaces (no optical interface)
- Frequency source   Compatible RF interfaces (no optical interface)
- SNMP                Not compatible

Contact **ViaLite Communications** or your local agent for more details.

## 4 ViaLiteHD System Components

### 4.1 ViaLiteHD 19" Chassis

#### 4.2 Description

The 19" chassis is suitable for 19" rack mounting, the chassis must be factory configured for either AC or DC power. Power supplies MUST match the chassis type (either AC or DC) failure to do so may result in permanent damage to your system. The modules fitted in the chassis may be either standard plug in or Blindmate, in any type of 1U chassis.

There are two factory configured AC powered versions; one version (HRK1C) accommodates two RF/data modules (5HP) and one control module (7HP); the other (HRK1S) accommodates three RF/data modules (5HP).

There are two factory configured DC powered versions one version (HRK1C-DC) accommodates two RF/data modules (5HP) and one control module (7HP); the other (HRK1S-DC) accommodates three RF/data modules (5HP).

The chassis front and rear power supplies provides full redundancy and maximum reliability to avoid traffic loss in the event of a power supply failure. Before removing any power supply, the input power must be isolated from that module.

Note: Each power supply position requires a separate power source to provide fully redundant protection.



HRK1C accommodates two RF/data modules and one control module, two power supplies (one front, one rear)



HRK1S accommodates three RF/data modules, two power supplies (one front, one rear)

The plug-in modules simply plug into the chassis, allowing the user to replace modules quickly and easily or to upgrade the system with additional modules at any time. For ease of upgrade and replacement, most modules are offered with the option of a Blindmate interface, where all interface cables connected to the chassis hardware and not the module.

Each of the RF/data module positions has a dedicated D type connector that provides access to all the digital data for that module; this is fitted to the chassis backplane.

All of the module digital alarms, analogue monitors, summary alarm relay, LNA power, external power are routed to a common chassis connector on the rear panel. This permits the integration of the *ViaLiteHD* equipment into a Maintenance & Control system.

All Module slots 1-3 have a data bus that can be used for sending and receiving data between modules.

### 4.3 Power Interface Management

External power can be provided to, or taken from the chassis via the "Common Chassis" connector J1, the current should be limited to 5A per pin. The power level (sum of chassis and external power) must be within the capability of the chassis power supplies, see specification in section 5.

#### 4.3.1 External backplane power

If the chassis is powered externally the input DC voltage measured at the common chassis connector should be 12Vdc +/- 0.5V. If chassis power supplies are also fitted we would advise that a low voltage drop diode (i.e. Schottky or similar) be used to OR the power feeds.

#### 4.3.2 Module bias feed

It is possible to provide a bias voltage from the modules to connected devices. Dependent on module type, this can be either internally sourced from the module or provided via the "Common Chassis" connector J1. The current limit is dependent on module type fitted.

### 4.4 Alarm Management

The alarm strategy on the *ViaLiteHD* system caters for all levels of Alarm and Monitoring System complexity from simple module failure LED indication, to local and remote end alarm notification and redundancy switching.

All modules provide an alarm output to the chassis backplane to indicate that the module is present and working correctly. The alarm is fail-safe in that when a working module is withdrawn from the chassis an alarm is registered for that module position.

#### 4.4.1 Common Chassis 25way Connector J1

All module alarms are provided for the user on the 25 way "Common Chassis" connector on the chassis rear panel. These outputs are "open collector" outputs. There are also two analogue monitors per module position. Their function depends on the type of module fitted.

#### 4.4.2 Connecting to an "open collector" output.

The alarm output pin should be connected to a suitable current source (a positive voltage via a 10kohm pull-up resistor is adequate). When the module is in a working (non-alarm) state, the alarm output pin is short circuited to ground by the module. If the module enters an alarm state, the alarm pin is released to a high impedance state and current is no longer drawn from the constant current source. In the case of a positive voltage and pull-up resistor, the voltage on the alarm output pin will rise to indicate the alarm state. It follows that, if a module is removed from the chassis, the alarm will be raised for that module position.

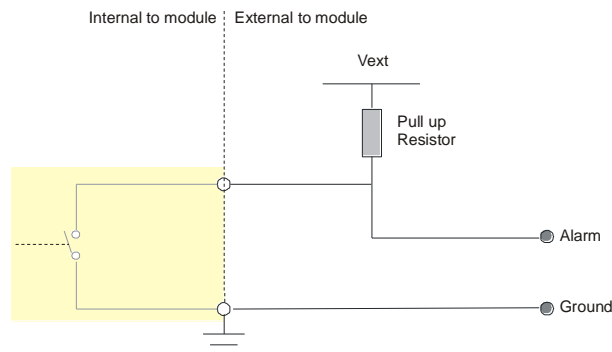

The capability of the open collector is dependent on the module that provides it. The typical capability of the Open Collector/Drain is 50mA maximum current sink and 15V maximum voltage (Vext)

#### 4.4.3 Summary Alarm

A summary alarm can be provided in an HRK1C chassis if an appropriate module is fitted in the 7HP slot. This function can be provided by either of the following modules

- SNMP control module (automatic sensing of module presence)
- Summary alarm relay module (manual setting of module presence)

If no module is fitted the summary alarm relay connections will all be open circuit.

If an appropriate module is fitted there is a volt free 3-pin connection present on "Common Chassis" Connector J1. The three connections are Normally Open (NO), Common (COM) and Normally Closed (NC).

Condition 1 - Power applied to Chassis, no alarms (i.e. normal condition)

- Pin NO is open circuit
- Pin NC is connected to COM

Condition 2 - Power removed from Chassis and/or one or more module alarms (i.e. Alarm condition)

- Pin NO is connected to COM
- Pin NC is open circuit

RELAY\_x [1= normally closed, 2=common, 3=normally open]

#### 4.4.4 Module Alarm Defeat

In some installations, the Chassis might not be fully populated with modules. In this case, the module alarm output for the vacant positions would register a continuous alarm state and the Summary Alarm Output would also register an alarm condition.

It is very important to ensure that the DIP switches on the Summary alarm relay module or software alarm mask of the SNMP control module for Chassis positions where modules are "present" is set correctly. If a DIP switches/software mask is set incorrectly for a "present" module, then if this module were to fail, NEITHER THE MODULE ALARM NOR THE SUMMARY ALARM WOULD DETECT THE FAILURE. The front panel LEDs of the module will always register an alarm condition correctly regardless of the state of the DIP switches/software mask.

#### 4.4.5 Using open collector alarms with controller cards

When a chassis is fitted with a controller card (i.e. SNMP and web controller or summary alarm card) all the alarm lines will be loaded and pulled up. The alarm lines are pulled up to as shown below.

SNMP and web controller pulled up to 3.3V via 4.7k ohms\* (see warning below)  
 Summary Alarm pulled up to 5V via 100k ohm, with series diode  
 \* Applying external voltage to these pins may cause damage, contact **ViaLite communications**

Note: the alarm line for slot 14 is always pulled up irrespective of the card status, these cards are all fitted with summary alarm relays.

#### 4.4.6 Using open collector alarms with RF switch and RF splitter cards

When a chassis is fitted with an RF switch or RF splitter card the alarm lines of the adjacent will be loaded and pulled up. The alarm lines are pulled up to as shown below.

RF switch or RF splitter pulled up to 5V via 10k ohm, with series diode

### 4.5 Heat management

The chassis is designed to meet its environmental specification, when operating in a typical configuration. A typical configuration is all modules populated (2\*Transceiver, 1\*SNMP, 2\*PSU), chassis power consumption 13 watts, no external DC power input or DC output and no obstruction to convection air path.

All module and power supply slots are cooled by convection.

- Airflow above chassis blocked: maximum operating temperature reduced by -10°C
- Airflow below chassis blocked: maximum operating temperature reduced by -5°C

Also see section 5.4 that details the typical power consumption of most common types of modules.

### 4.6 Unused module positions

We advise that all unused slots be fitted with blanking panels. Different widths of blanking panel are available. They fit the 5HP general purpose (slots 1-2 or 1-3), 7HP controller card slots (slot 3). They can be used with any **ViaLiteHD** 19inch chassis and will prevent accidental/unwanted access and the ingress of dust.

Blanking panels are not fitted to an unused power supply position, but any unfitted power supply slot MUST be isolated from the AC power source. **ViaLite Communications** provide blanking plugs for any unused AC inlet. If only a single PSU is in use it should be fitted in the front position.

Blanking panels available are.

- |           |  |  |
|-----------|--|--|
| • 85050   | <b>ViaLiteHD</b> Blank Panel, 5HP reusable | Slots 1-2 (in HRK1C), Slots 1-3 (in HRK1S) |
| • 85049   | <b>ViaLiteHD</b> Blank Panel, 7HP reusable | Slot 3 (in HRK1C)                          |
| • 85044   | <b>ViaLiteHD</b> Blank Panel, 5HP          | Slots 1-2 (in HRK1C), Slots 1-3 (in HRK1S) |
| • 85046   | <b>ViaLiteHD</b> Blank Panel, 7HP          | Slot 3 (in HRK1C)                          |
| • HPS-1-0 | <b>ViaLiteHD</b> Blank plug, power supply  | Slots 4-5                                  |

Contact **ViaLite Communications** or your local agent for more details.



The 5 and 7 HP blanking panels (85044 and 85046) are fitted with snap-in plastic barb. These are designed to permanently hold the blanking panel in position. Please ensure that you have fully planned the configuration of your cabinet, as the plastic barb is a close tolerance fit and removal results in the barb being broken; the panel should then be discarded. If you wish to remove the card, reusable panels can be ordered (85050 and 85049).



85044 *ViaLiteHD* Blank Panel, 5HP

85046 *ViaLiteHD* Blank Panel, 7HP

HPS-1-0 Blank plug

The power supply blanking plugs are friction fitted, they are simply inserted and withdrawn from the IEC inlets, they are a tight tolerance fit to ensure that they are retained in position.

**4.7 Minimum power supply load**

The 1U chassis has no minimum load requirement for either AC or DC versions

**4.8 Chassis Specification**

	HRK1C	HRK1C-DC	HRK1S	HRK1S-DC
Description	19" Rack Mounting Chassis			
Max. No. of 5HP modules	2 (in slots 1-2 only)		3 (in slots 1-3)	
Max. No. of 7HP modules	1 (in slots 3 only)		None	
Max. No. of PSU modules	2 (in slots 4,5 only)			
19" Rack Mounting	Yes			
Desktop Mounting	Not Suitable (use <i>ViaLite Classic</i> products)			
Width, internally	84 HP			
Width, externally	483 mm			
Height, internally	1U			
Height, externally	44 mm			
Depth, externally	335 mm			
Maximum weight	1.2 kg (Chassis ONLY), 2.6 kg (Chassis and slot modules)			
Cooling	Convection			
Operating Temperature	-10°C to +50°C			
Humidity	0-95%, Non-condensing			
Compatible Power Supply	HPS-1 HPS-1-0	HPS-1-DC HPS-1-DC24 HPS-1-DC48	HPS-1 HPS-1-0	HPS-1-DC HPS-1-DC24 HPS-1-DC48
Chassis power input	2 x IEC 60320, 3 pins each Live & Neutral isolated Earth to chassis	2 x 4mm screw terminal, 2 pins each Positive and negative isolated	2 x IEC 60320, 3 pins each Live & Neutral isolated Earth to chassis	2 x 4mm screw terminal, 2 pins each Positive and negative isolated
Chassis earth	Rear panel M4 stud Earth to chassis and common with backplane/RF GND			
Module "Data Connector" J8, J9 (J12): 9 way D	9way Female D with screw-lock termination at the rear of the chassis (1 per 5 HP slot). • Data input/output for individual modules.			
"Common Chassis" Connector J1: 25 way D	25way Female D with screw-lock termination at the rear of the chassis • This concentrates all the modules and chassis connections in one location.			
<i>ViaLiteHD</i> plug-in/ blindmate module compatibility	All types			

**4.9 Chassis connector pinouts**

**Pin out – J1 “Common Chassis” connector\***

Pin	Chassis J1	Pin	Chassis J1	Pin	Chassis J1	Pin	Chassis J1
1	ALARM_1	8	LNA_feed_2	15	ALARM_P_1	22	GND
2	ALARM_3	9	GND	16	Analogue_monitor_B_1	23	BUC_feed_2
3	ALARM_P_2	10	BUC_feed_1	17	Analogue_monitor_B_2	24	Relay_1 (NC)
4	GND	11	BUC_feed_3	18	Analogue_monitor_A_1	25	Relay_3 (NO)
5	Analogue_monitor_B_3	12	Relay_2 (COM)	19	Analogue_monitor_A_3		
6	Analogue_monitor_A_2	13	+12Vdc	20	LNA_feed_1		
7	GND	14	ALARM_2	21	LNA_feed_3		

Note: The Chassis and power ground are common

Note: See your module handbooks for assignment and function of the “Analogue\_monitor” pins

**Pin Out – J8, J9 (HRK1C and HRK1S) and J12 (HRK1S only) “Module Data” connectors**

Data on the connector is only for the module fitted in that 5HP slot (J8 = slot 1, J9 = slot 2, J12 = slot 3 [HRK1S only])

Data available depends on the type of module fitted to that slot. This data is only available on module with digital channels.

If connected to a **TX module** (single transmitter)

Pin	Module	Pin	Module	Pin	Module
1	GND	4	<i>Do not connect</i>	7	<i>RX_422_OUT-</i>
2	<i>Do not connect</i>	5	<i>Do not connect</i>	8	<i>RX_232_OUT [TTL_OUT]*</i>
3	<i>Do not connect</i>	6	<i>RX_422_OUT+</i>	9	<i>RX_RTS_485</i>

If connected to a **RX module** (single receiver)

Pin	Module	Pin	Module	Pin	Module
1	GND	4	<i>TX_232_IN [TTL_IN]*</i>	7	<i>Do not connect</i>
2	<i>TX_422_IN+</i>	5	<i>Do not connect</i>	8	<i>Do not connect</i>
3	<i>TX_422_IN-*</i>	6	<i>Do not connect</i>	9	<i>Do not connect</i>

If connected to a **TRX module** (transceiver)

Pin	Module	Pin	Module	Pin	Module
1	GND	4	<i>TX_232_IN [TTL_IN]*</i>	7	<i>RX_422_OUT-</i>
2	<i>TX_422_IN+</i>	5	<i>Do not connect</i>	8	<i>RX_232_OUT [TTL_OUT]*</i>
3	<i>TX_422_IN-*</i>	6	<i>RX_422_OUT+</i>	9	<i>RX_RTS_485</i>

If connected to a **DTX module** (dual transmitter)

Pin	Module	Pin	Module	Pin	Module
1	GND	4	<i>TX1_232_IN [TTL1_IN]*</i>	7	<i>TX2_422_IN-</i>
2	<i>TX1_422_IN+</i>	5	<i>Do not connect</i>	8	<i>TX2_232_IN [TTL2_IN]*</i>
3	<i>TX1_422_IN-</i>	6	<i>TX2_422_IN+</i>	9	<i>Do not connect</i>

If connected to a **DRX module** (dual receiver)

Pin	Module	Pin	Module	Pin	Module
1	GND	4	<i>RX1_232_OUT [TTL1_OUT]*</i>	7	<i>RX2_422_OUT-</i>
2	<i>RX1_422_OUT+</i>	5	<i>RX1_RTS_485</i>	8	<i>RX2_232_OUT [TTL2_OUT]*</i>
3	<i>RX1_422_OUT-</i>	6	<i>RX2_422_OUT+</i>	9	<i>RX2_RTS_485</i>

If connected to a **Serial module** (transceiver)

Pin	Module	Pin	Module	Pin	Module
1	GND	4	<i>TX_232_IN [TTL_IN]*</i>	7	<i>RX_422_OUT-</i>
2	<i>TX_422_IN+</i>	5	<i>Do not connect</i>	8	<i>RX_232_OUT [TTL_OUT]*</i>
3	<i>TX_422_IN-*</i>	6	<i>RX_422_OUT+</i>	9	<i>RX_RTS_485</i>

\* Modules equipped with TTL use the RS232 signalling pins

Note: Connections in *Blue text* are optional and only available on some types of module.

Note: Colour indicates relevant connector drawing

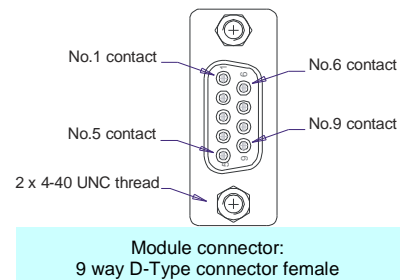
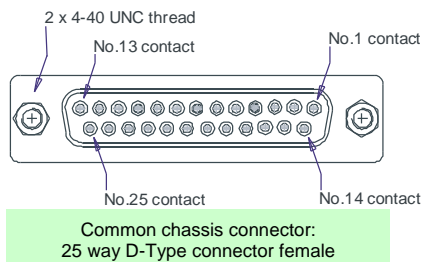

All connectors are viewed looking into connector from mating interface  
Each connector is shown in the correct orientation for normally mounted 1U chassis



HRK1C View of interface connectors on the rear of the chassis (no modules fitted)



HRK1S View of interface connectors on the rear of the chassis (no modules fitted)



HRK1C-DC View of interface connectors on the rear of the chassis (no modules fitted)



HRK1S-DC View of interface connectors on the rear of the chassis (no modules fitted)

#### 4.10 LNA feed and BUC feed pin assignment for different module types

The function of J4 pins described as LNA\_feed and BUC\_feed can vary dependant on the module type. The table below shows pin assignment for all different module types.

The “X” used on the pin assignment indicates the slot to which the LNA or BUC feed is connected (i.e. LNA\_feed\_2 is connected to slot 2).

When an “A” or “B” suffix is shown this is used to indicate which channel of the dual module (i.e. “LNA\_feed\_A\_X” the LNA or BUC feed) is connected to. It will match with the connector letter on the rear panel. In a 1U rack where the modules are orientated horizontal, channel “A” is the right most channel and channel “B” is the left most channel, viewed from the rear of the chassis. Transceivers always have the receiver as channel “A” and the transmitter as channel “B”.

The LNA and BUC feed will only be connected if the module in the slot has this appropriate functionality.

J4 pin assignment for a transmitter, TX module

	Rack J4, LNA_feed_X	BUC_feed_X (J4)
TX	LNA_feed_X	NC (Not Connected)

J4 pin assignment for a receiver, RX module

	Rack J4, LNA_feed_X	BUC_feed_X (J4)
RX	NC (Not Connected)	BUC_feed_X

J4 pin assignment for a transceiver, TRX module

	Rack J4, LNA_feed_X	BUC_feed_X (J4)
TRX	LNA_feed_X	BUC_feed_X

J4 pin assignment for a dual transmitter, DTX module

	Rack J4, LNA_feed_X	BUC_feed_X (J4)
DTX	LNA_feed_A_X	LNA_feed_B_X

J4 pin assignment for a dual receiver, DRX module

	Rack J4, LNA_feed_X	BUC_feed_X (J4)
DRX	BUC_feed_A_X	BUC_feed_B_X

J4 pin assignment for a Switch, SW module

	<b>Rack J4, LNA_feed_X</b>	<b>BUC_feed_X (J4)</b>
SW	Switch_feed_X	NC (Not Connected)

J4 pin assignment for a Splitter, SP module

	<b>Rack J4, LNA_feed_X</b>	<b>BUC_feed_X (J4)</b>
SP	Splitter_feed_X	NC (Not Connected)

J4 pin assignment for a single Amplifier, AMP module

	<b>Rack J4, LNA_feed_X</b>	<b>BUC_feed_X (J4)</b>
AMP	Amplifier_feed_X	NC (Not Connected)

J4 pin assignment for a Dual Amplifier, AMP module

	<b>Rack J4, LNA_feed_X</b>	<b>BUC_feed_X (J4)</b>
AMP	Amplifier_feed_A_X	Amplifier_feed_B_X

## 5 ViaLiteHD Power Supplies

### 5.1 Slide in Chassis AC Power Supplies, HPS-1

The HPS-1 power supply has an AC input PSU that provides DC power to all plug-in modules in the 19" chassis. The HPS-1 has a universal AC mains input. There are two power supply positions in chassis, slot 4 on the chassis left hand side fitting from the front and slot 5 also on the left hand side fitting from the rear. HPS modules will provide dual redundant operation. Separate mains power supply connections mean that they can be operated from different supplies for even higher levels of availability. During normal operation, the output of the power supplies are diode OR'd, hence one unit will provide most if not all of the chassis power requirements. In the event of a failure all the chassis current can be provided by the remaining operational module. The Power supply front panel LED provides a visual indication of failure, and a power good alarm output is available for use at the "Chassis common" connector.

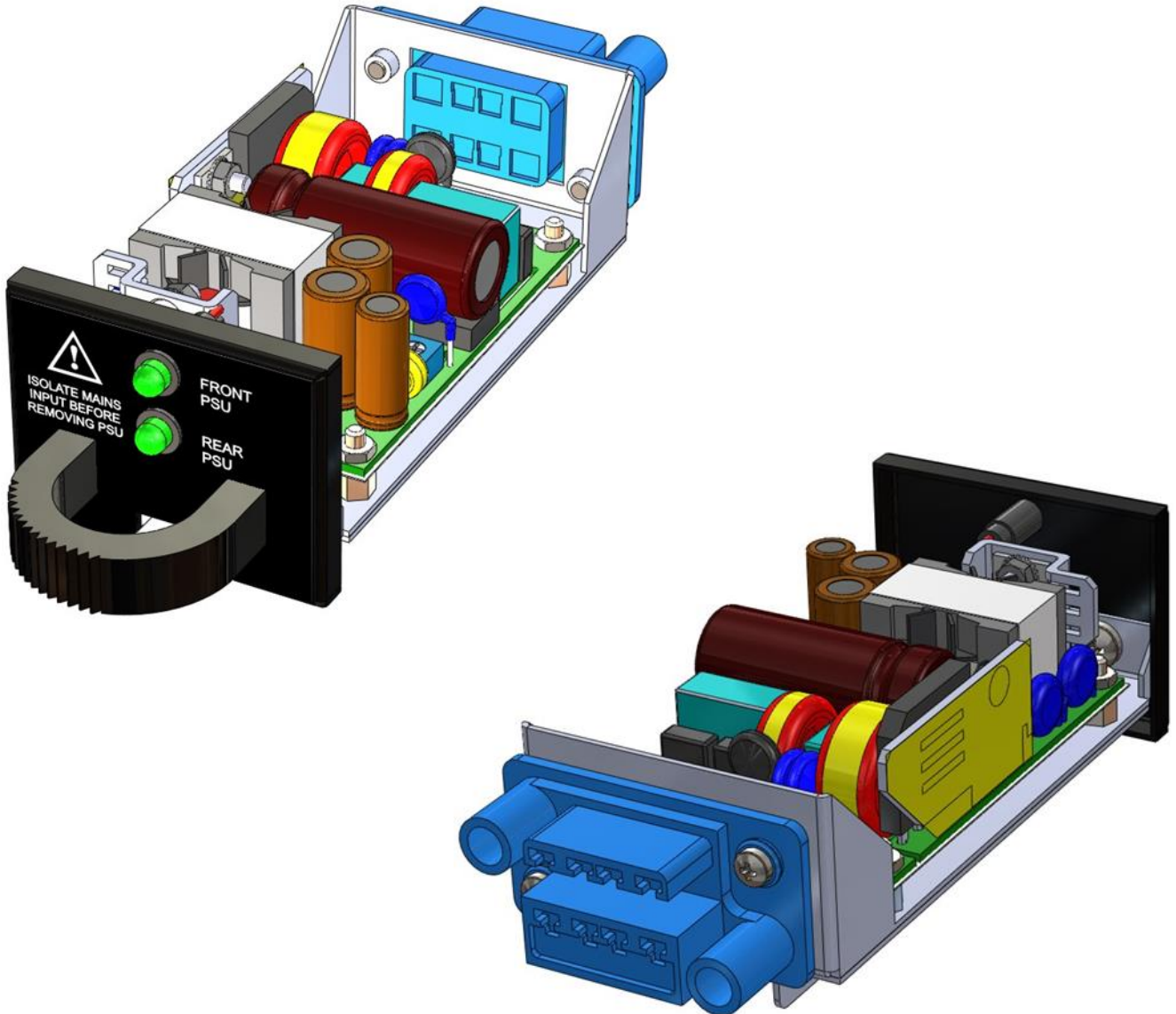

The HPS-1 power supply has a wide range alternating current (AC) input and can operate from 110V and 230V nominal mains supplies. Mains power is applied at the rear of the chassis via an earthed IEC60320 connector, and regulated direct current (DC) power is supplied to the Chassis Backplane PCB for distribution to the plug-in modules. This connector is also used for reporting PSU alarm status.

The power supply is internally fused on both the live and neutral lines; these fuses will only fail under gross fault conditions. The fuse is not replaceable, the unit must be returned to **ViaLite Communications** for replacement.

On the front panel the module has two LED indicators. These report the status of both the power supply modules. IF the LED is **GREEN** the module is operating in its normal non-alarm state. If the LED is OFF, the power supply is not supplying 12V and has failed.

These AC power supplies **MUST ONLY** be fitted in AC chassis types.

## 5.2 Slide in Chassis DC Power Supplies, HPS-1-DC

The HPS-1-DC power supply has a DC input that provides DC power to all plug-in modules in the 19" chassis. The HPS-1-DC has wide range DC power input. There are two power supply positions in the chassis, slot 4 on the chassis left hand side fitting from the front and slot 5 also on the left hand side fitting from the rear. HPS modules will provide dual redundant operation. Separate DC supply connections mean that they can be operated from different supplies for even higher levels of availability. During normal operation, the output of the power supplies are diode OR'd, hence one units will provide most if not all the chassis power requirements. In the event of a failure all the chassis current can be provided by the remaining operational module. The Power supply front panel LED provides a visual indication of failure, and a power good alarm output is available for use at the "Chassis common" connector.

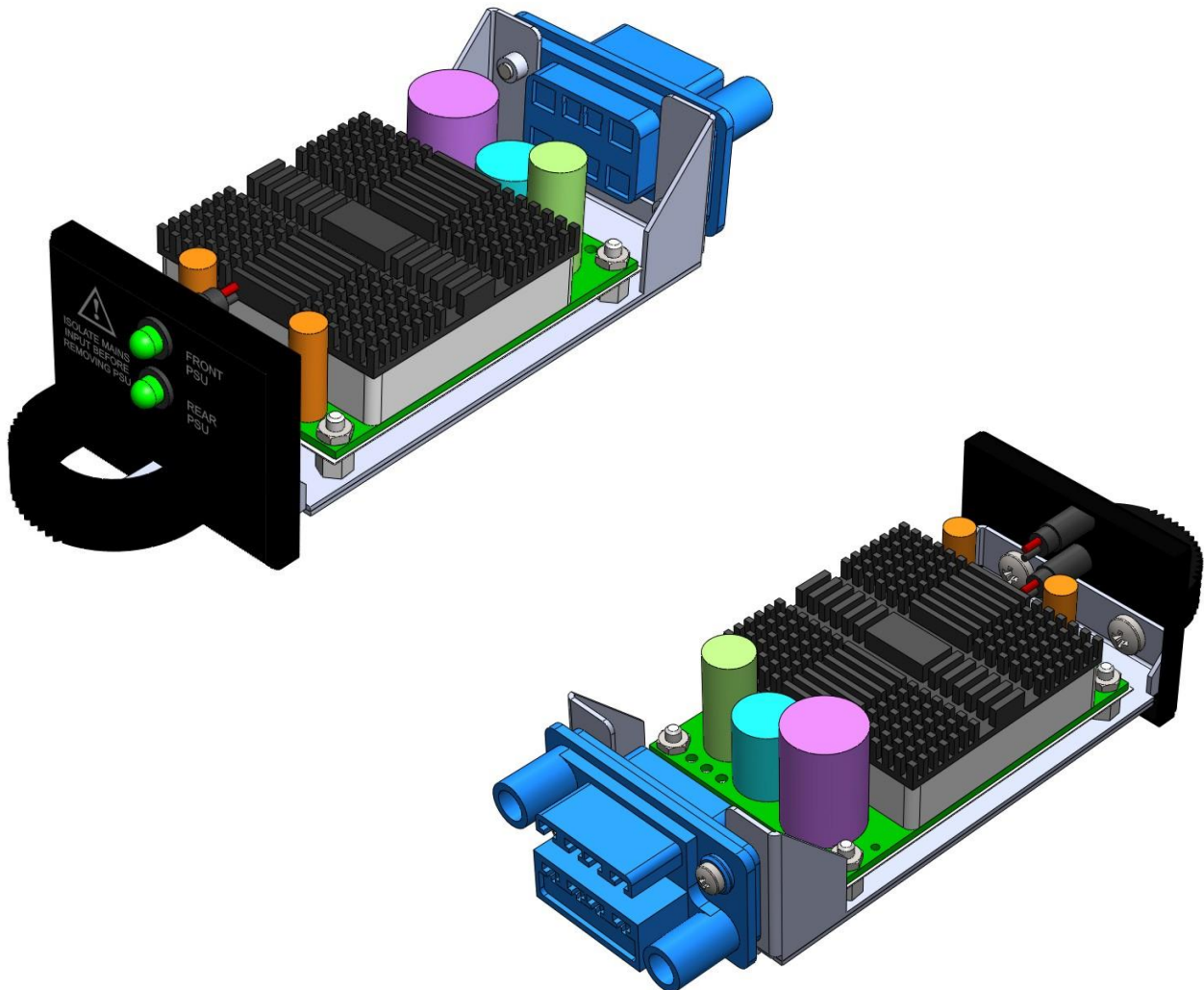

The HPS-1-DC power supply has a wide range direct current (DC) input and can operate from 20V to 72V nominal DC supplies. DC power is applied at the rear of the chassis via 4mm screw terminals, and regulated direct current (DC) power is supplied to the chassis backplane PCB for distribution to the plug-in modules. This connector is also used for reporting PSU alarm status.

Each HPS-1-DC PSU is capable of supplying 40W of output power, this should be sufficient to power most chassis configurations with some margin. The HPS-1-DC is supplied as the standard DC power supply for the 1U chassis. If higher output power is required (up to 60W) different power supplies can optionally be provided, the HPS-1-DC24 and HPS-1-DC48 have a narrower voltage input range see paragraph 5.3, please contact **ViaLite Communications** for more details.

The DC power supply is internally fused ONLY on the positive input; this fuse will only fail under gross fault conditions. The fuse is replaceable – access to the fuse is from the bottom of the module. See section 5.2.1 for more details.

On the front panel the module has two LED indicators. These report the status of both the power supply modules. IF the LED is **GREEN** the module is operating in its normal non-alarm state. If the LED is OFF, the power supply is not supplying 12V and has failed.

These DC power supplies **MUST ONLY** be fitted in DC chassis types.

### 5.2.1 Fuse replacement in DC Power Supplies

To replace the fuse of the HPS-1-DC you will need a tweezers or small pliers.

- Isolate the power input to the supply.
- Remove the power supply from the chassis.
- Use a pair of tweezers to remove the failed fuse.
- NOTE: The fuse is fitted in a socket, see below for a picture of the removable part
- Replace the fuse with a suitable part, details below.
- Check the fuse is securely fixed.
- Replace the power supply.
- Restore the power input to the supply.

Suitable replacement fuse:

Description: 5A, 125V, slow blow, OMNI-BLOK, SMD socketed

PPM part number: 59887

Source: Littelfuse Suppliers part number: 0454005.MR

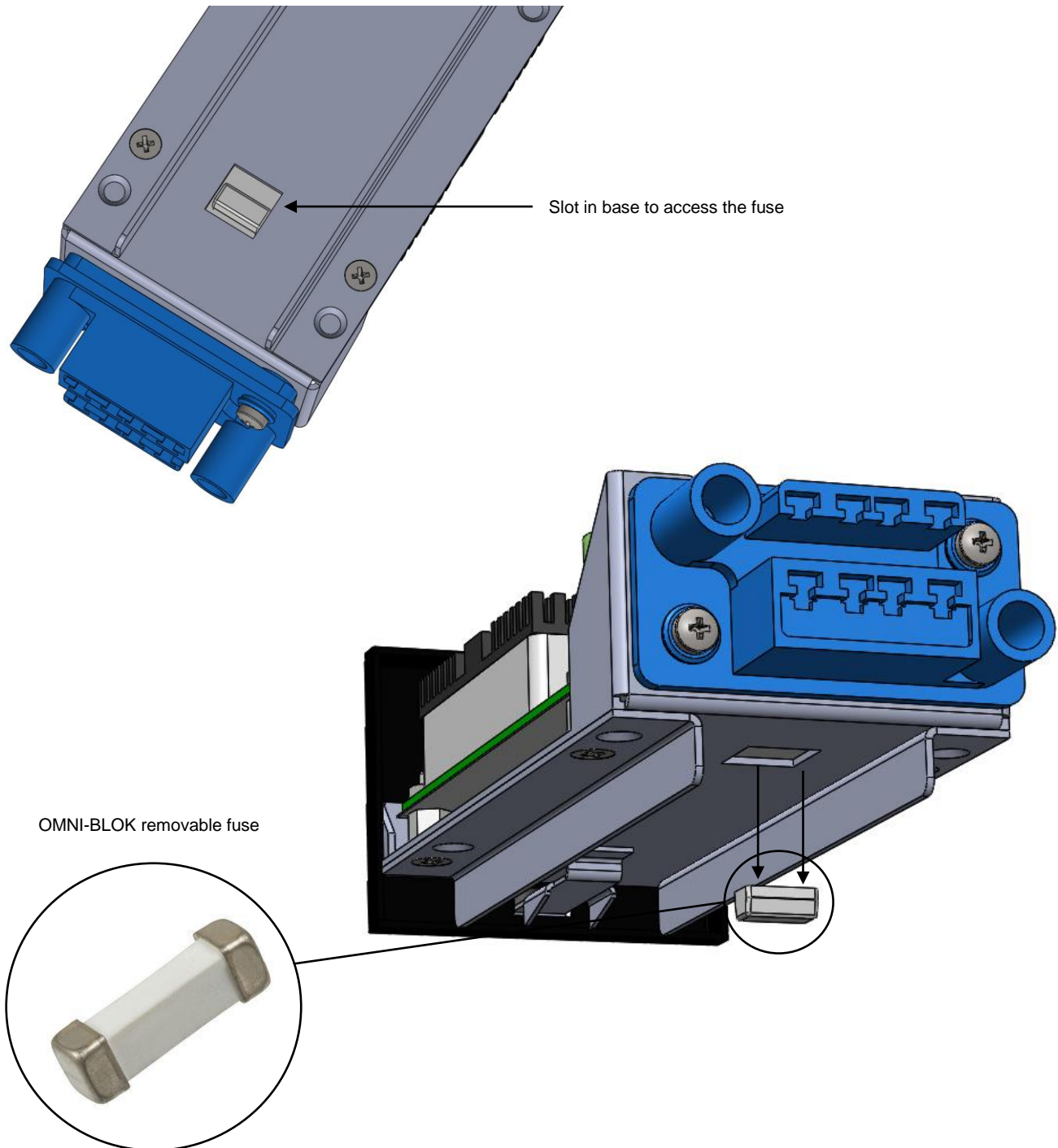

### 5.3 Specification

	HPS-1	HPS-1-DC	HPS-1-DC24	HPS-1-DC48
Description	Wide input range AC power supply			
Dimensions, internal (W x H)	1U high			
Dimensions, external (W x H x D)	41 x 53 x 130 mm			
Weight	0.25 kg			
Input Supply Power	88 - 264V Nominal 110V/230Vac at 50/60Hz,	20 – 72Vdc	18-36Vdc	36-72Vdc
Fuse [Fused inputs]	Internal, 15A / 250V [LIVE and NEUTRAL]	Internal, 5A / 125V [POSITIVE]		
Efficiency	85% typical	89% Typical	90% Typical	
Switch on current, cold start	<40A @ 230Vac	<4.5A @ 20V	<4.5A @ 36V	
Output voltage	12.0 +/- 0.5Vdc			
Output ripple	120mV pk-pk			
Maximum input current	1.0A	2.5A	1.4A	
Maximum output power	60 W	40W	60 W	
Minimum load power	No minimum load			
Inlet air temperature	-10 to +50°C			
Derating >+50°C	2.5% / °C, absolute maximum 70°C			
Hot-swapping	No, power must be isolated before extracting modules and not restored until new unit is in place			
Dual Redundant	Yes			
Output overload	Built in overload protection switches output OFF and automatically restarts at >130% nominal current			
Output over voltage protection	14Vdc Typical	15Vdc Typical		
Status Indicators	Front panel GREEN power LED, one for front and one for rear module			
Rear Panel alarm outputs	Power Good on J1 "Chassis common" connector 12V = Normal operation; 0V = Alarm			
Cooling	Convection			
MTBF @25°C at 100% load	470 000 hours	150 000 hours	110 000 hours	

### 5.4 19" Chassis Power Requirements

Ensure that the power supplies fitted in your system are sufficient to power the complete system. The power supplies are design to operate in dual redundancy, without current sharing. Hence power capability of one supply must be sufficient to power the complete chassis.

The exact power requirements of modules are given in the module handbooks, however the details below maybe used to approximate the power output requirements from the chassis mounted PSUs.

The input power requirements can be calculated by using the power supply efficiency given in section 5.3.

Single Transmitter	2.0 W Typical per slot, excluding LNA/LNB power
Single DWDM Transmitter	3.2 W / 4.0W / 6.0 Typical per slot at 25/50/70°C, laser types "D", "E" and "K", excluding LNA/LNB power
Single Receiver	1.5 W Typical per slot
Dual Transmitter	4.0 W Typical per slot, excluding LNA/LNB power
Dual Receiver	2.6 W Typical per slot
Transceiver	3.3 W Typical per slot, excluding LNA/LNB power
Amplifier	2.4W Typical per slot
Serial Digital	0.7W Typical per slot
Switch	0.4W Typical per slot
Splitter	0.4W Typical per slot
Ethernet	1.9W Typical per slot
SNMP controller	4.0 W Typical per slot
Alarm and Load	1 W Typical, plus 0/3/6/9/12 W load, per slot
Redundancy load module	1 W Typical, plus 0/3/6/9/12 W load, per slot
LNA/LNB feed	up to an additional 14.6 W per slot, if used (efficiency 89% typically and 80% minimum).
AC to DC efficiency	see section 5.3
DC to DC efficiency	see section 5.3



## 6 Installation Guide

### 6.1 Chassis Installation

The **ViaLiteHD** Power Supply Modules do not have an isolating switch on the mains voltage inlet. For this reason, the **ViaLiteHD** Chassis **MUST** be installed within easy reach of a clearly labelled dual pole mains isolation switch, which supplies the equipment.

The **ViaLiteHD** 19" Chassis is designed to fit 19" racks and occupies a height of 1U. The Chassis is provided with flanges for mounting to the rack. The Chassis backplane contains 9-way D-type data connectors for each module position. This provides user access to data connections from relevant modules (depends on module type). The pinouts of these connectors depend on the type of module in use in that chassis position. There is also a "Common Chassis" connector providing access to alarms, monitoring information from all modules, power feeds and the summary alarms.

We would advise that the sides of the chassis are supported by additional rails (such as Schroff slide rails) to minimise stress on the chassis.

### 6.2 Power Supply Module Installation (slots 4 and 5)

The **ViaLiteHD** Power Supply Module powers the plug-in modules via the Chassis backplane PCB. It occupies slots 4 and 5.

To install a power supply module

- Ensure the power to power supply module is isolated.
- Align the module ensuring that the guides on the sledge engage in the crows feet.
- While fully lifting the catch gently push the module down its guide, applying pressure via the handle; ensure as the module fully engages and that the front panel is fully within the chassis slot.
- When full engaged the module should lock in position.
- Power may now be applied.

To remove a power supply module

- Isolate power to the module to be removed.
- Fully lift the catch with one finger and pull the module towards yourself with another finger.
- The module can be fully withdrawn.
- If the slot is to be left unpopulated for any period of time please fit the modules inlet with an HPS-1-0 blanking plug.

### 6.3 5HP Standard Plug-in Modules (slots 1-2 HRK1C, slots 1-3 HRK1S)

All **ViaLiteHD** plug-in modules are hot-swappable, so it is not necessary to power-down the chassis before inserting a module. All standard optical connectors are retained by the module. So it will be necessary to either disconnect any cables or have a sufficiently long service loop.

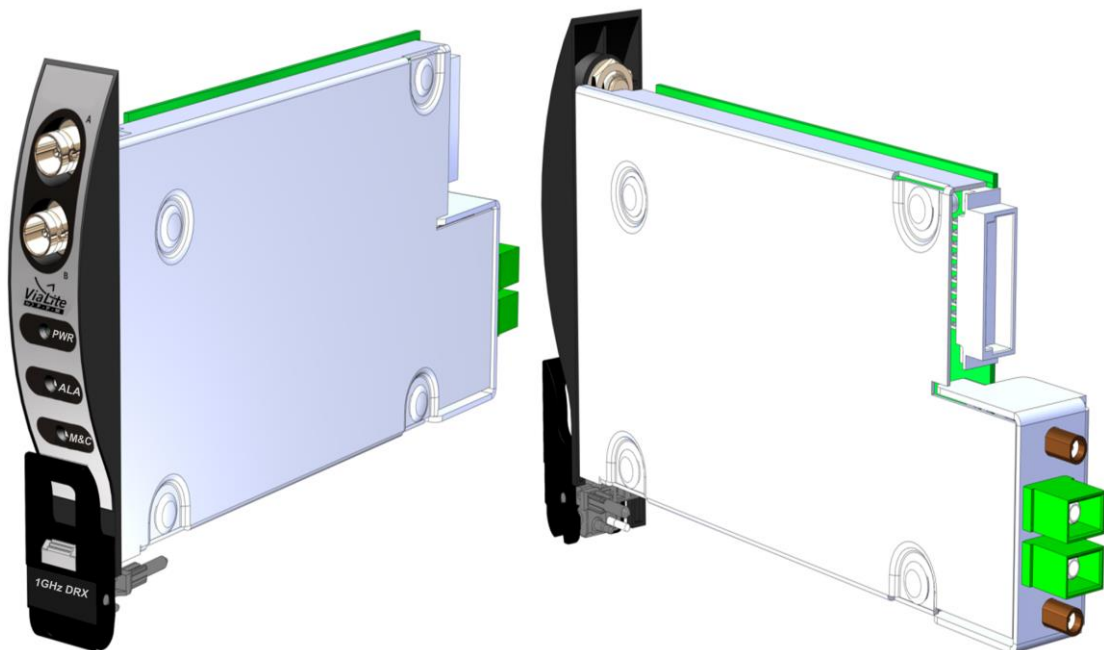

To install a 5HP Standard module and matching interface plate

- The protective covers on the connectors may be left in place.
- Push the release button of the module handle down and simultaneously pull the top of the handle forwards.
- Align the module to the front face of the chassis so that the PCB slides into the "crow's feet" card guides top and bottom.
- Gently push the module down its guide, applying pressure via the handle, you may also apply pressure between the LED and test connector.
- As the module is fully mated the top of the handle should snap back and lock in position.

- The pawls of the handle should be fully engaged in the matching slots.
- If power is applied to the chassis the module power LED should light as soon as the module is fully inserted.
- Remove protective covers and connect any interface cables.



To remove a 5HP Standard module

- Disconnect any cables if necessary.
- Push the release button of the module handle down and simultaneously pull the top of the handle forwards.
- Apply pressure via the handle and gently withdraw the module from the chassis.

#### 6.4 5HP Blind-mate Plug-in Modules (slots 1-2 HRK1C, slots 1-3 HRK1S)

All *ViaLiteHD* plug-in modules are hot-swappable, so it is not necessary to power-down the Chassis before inserting a module. All blind mate optical connectors are provided with spring loaded covers that will protect the optics of any inserted modules. As there is no cover on the opposite side, mating cables should not be installed until the slot modules are present. There are 2 types of blind mate, type 'D' and type 'E' as shown in the images below. A type 'E' module is not compatible with a type 'D' rack plate. Likewise a type 'D' module is not compatible with a type 'E' rack plate. Should this happen in error stoppers will prevent any damage to the connectors.

To install a blind mate module and matching interface plate

- Firstly inspect the rear Blind-mating plate, ensure that the connector barrels are fitted into all RF connectors (Type 'D') and are centrally aligned.
- Remove protective covers from the inside face of the optical connector if fitted.
- Ensure that the rear plate is free of any dust and contamination, if necessary clean with filtered compressed air.
- Screw the Blind-mating plate into the appropriate slot at the rear of the chassis, using the supplied screws and a "Pozidriv Number 1" screwdriver.
- Push the release button of the module handle down and simultaneously pull the top of the handle forwards.
- Remove the protective cover from the modules optical connectors and clean any optical connectors.
- Align the module upright to the front face of the chassis so that the PCB slides into the "crow's feet" card guides top and bottom.
- Gently push the module down its guide, applying pressure via the handle, you may also apply pressure between the LED and test connector.
- As the module is fully mated the top of the handle should snap back and lock in position.
- The pawls of the handle should be fully engaged in the matching slots.
- If power is applied to the chassis the module power LED should light as soon as the module is fully inserted.
- Connect any interface cables to the blind-mate plate.

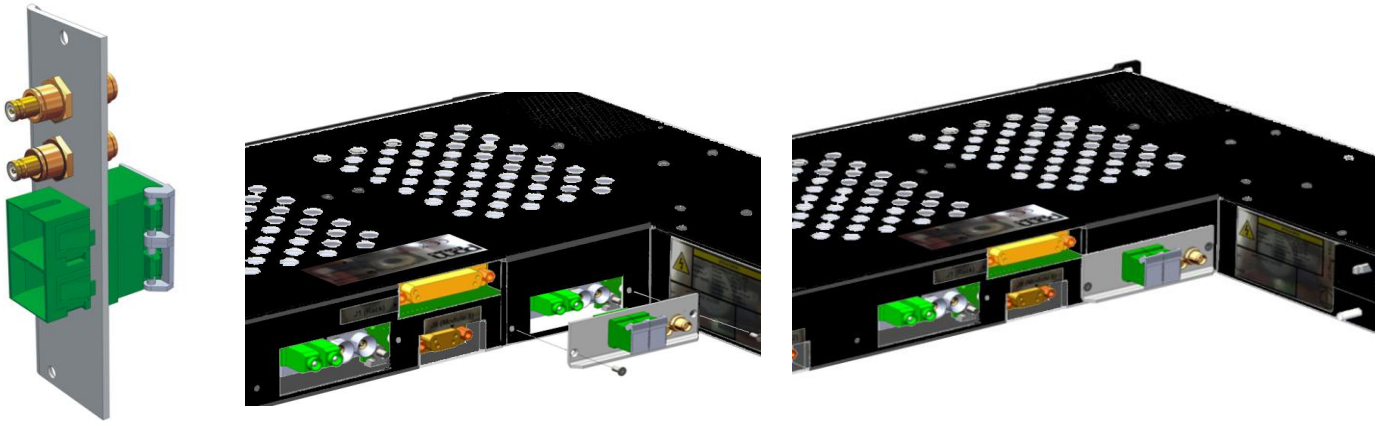
Type 'D' Blind-matesType 'E' Blind-mates

## To remove a blind-mate module

- Push the release button of the module handle down and simultaneously pull the top of the handle forwards.
- Apply pressure via the handle and gently withdraw the module from the chassis.
- For the Type 'D' Blind-mates check that the RF mating barrel is retained by the chassis Blind-mating plate.
- All cables will be retained by the chassis.

Note if modules are absent for an extended period there is chance of the optical fibres being contaminated as the optical mating interface is unprotected. If this happens it will be necessary to clean both the blind mating adaptor and fibre optic cable.

**6.5 7HP Standard Plug-in Modules (slot 3 HRK1C)**

All *ViaLiteHD* plug-in modules are hot-swappable, so it is not necessary to power-down the chassis before inserting a module. All standard optical connectors are retained by the module. So it will be necessary to either disconnect any cables or have a sufficiently long service loop.



To install a 7HP Standard module

- The protective covers on the connectors may be left in place.
- Push the release button of the module handle down and simultaneously pull the top of the handle forwards.
- Align the module to the front face of the chassis so that the PCB slides into the “crow’s feet” card guides top and bottom.
- Gently push the module down its guide, applying pressure via the handle, you may also apply pressure between the LED and test connector.
- As the module is fully mated the top of the handle should snap back and lock in position.
- The pawls of the handle should be fully engaged in the matching slots.
- If power is applied to the chassis the module power LED should light as soon as the module is fully inserted
- Remove protective covers and connect any interface cables



To remove a 7HP Standard module

- Disconnect any cables if necessary.
- Push the release button of the module handle down and simultaneously pull the top of the handle forwards.
- Apply pressure via the handle and gently withdraw the module from the chassis.

#### 6.6 **5HP blanking panel installation (slots 1-2 HRK1C, slots 1-3 HRK1S)**

Blanking panels should be the last panel installed into your chassis

To install the blanking panel

- Firstly inspect the blanking panel ensure that the plastic barbs are in good condition.
- Align the plastic barbs with the larger holes centrally above and below the slot on the chassis top and bottom rails.
- Firmly push the panel in until you feel the barbs click.

To remove the blanking panel

- Pull the blanking panel towards you, it may be necessary to use extra leverage.
- Discard the panel as the plastic barbs will now be over stressed and will not provide a reliable fixing.

### 6.7 7HP blanking panel installation (slots 3 HRK1C)

Blanking panels should be the last panel installed into your chassis

To install the blanking panel

- Firstly inspect the blanking panel ensure that the plastic barbs are in good condition.
- Align the plastic barbs with the larger holes centrally above and below the slot on the chassis top and bottom rails.
- Firmly push the panel in until you feel the barbs click.

To remove the blanking panel

- Pull the blanking panel towards you, it may be necessary to use extra leverage.
- Discard the panel as the plastic barbs will now be over stressed and will not provide a reliable fixing.

### 6.8 Power supply blanking panel installation (slots 4, 5)

Blanking panels HPS-1-0 should be fitted on any unused AC power supply inputs, to ensure there are no exposed AC connections.

To install the blanking panel

- Align with the PSU connector and push in. Removal is the opposite of installation.

### 6.9 Separate blind-mate panels

If you wish to pre-populate and cable your blind-mate chassis in advance, chassis plates can be purchased as spares, details below.

- PPM part number 85058 ViaLiteHD, Chassis plate, Blind mate (Type 'D'), 1 \* SMA 50ohms, 1 \* SC/APC
- PPM part number 85059 ViaLiteHD, Chassis plate, Blind mate (Type 'D'), 2 \* SMA 50ohms, 2 \* SC/APC
- PPM part number 85060 ViaLiteHD, Chassis plate, Blind mate (Type 'D'), 1 \* BNC 75ohms, 1 \* SC/APC
- PPM part number 85061 ViaLiteHD, Chassis plate, Blind mate (Type 'D'), 2 \* BNC 75ohms, 2 \* SC/APC
- PPM part number 85064 ViaLiteHD, Chassis plate, Blind mate (Type 'D'), 1 \* F-Type 75ohms, 1 \* SC/APC
- PPM part number 85065 ViaLiteHD, Chassis plate, Blind mate (Type 'D'), 2 \* F-Type 75ohms, 2 \* SC/APC
- PPM part number 85066 ViaLiteHD, Chassis plate, Blind mate (Type 'D'), 2 \* SMA 50ohms
- PPM part number 85067 ViaLiteHD, Chassis plate, Blind mate (Type 'D'), 3 \* SMA 50ohms
- PPM part number 85068 ViaLiteHD, Chassis plate, Blind mate (Type 'D'), 4 \* SMA 50ohms
- PPM part number 85069 ViaLiteHD, Chassis plate, Blind mate (Type 'D'), Duplexed, 1 \* SMA 50ohms, 1 \* SC/APC
- PPM part number 85070 ViaLiteHD, Chassis plate, Blind mate (Type 'D'), Duplexed, 1 \* BNC 75ohms, 1 \* SC/APC
- PPM part number 85071 ViaLiteHD, Chassis plate, Blind mate (Type 'D'), 1 \* BNC 50ohms, 1 \* SC/APC
- PPM part number 85072 ViaLiteHD, Chassis plate, Blind mate (Type 'D'), 2 \* BNC 50ohms, 2 \* SC/APC.
- PPM part number 85073 ViaLiteHD, Chassis plate, Blind mate (Type 'D'), 2 \* SC/APC
- PPM part number 85103 ViaLiteHD, Chassis plate, Blind mate (Type 'E'), 1 \* SMA 50ohms, 1 \* LC/APC
- PPM part number 85104 ViaLiteHD, Chassis plate, Blind mate (Type 'E'), 2 \* SMA 50ohms, 2 \* LC/APC
- PPM part number 85105 ViaLiteHD, Chassis plate, Blind mate (Type 'E'), 1 \* BNC 75ohms, 1 \* LC/APC
- PPM part number 85106 ViaLiteHD, Chassis plate, Blind mate (Type 'E'), 2 \* BNC 75ohms, 2 \* LC/APC
- PPM part number 85107 ViaLiteHD, Chassis plate, Blind mate (Type 'E'), 2 \* SMA 50ohms
- PPM part number 85108 ViaLiteHD, Chassis plate, Blind mate (Type 'E'), 3 \* SMA 50ohms

### 6.10 Electrical power connection

Power should be applied to the chassis with the supplied power cords, if these are not used a suitable alternative should be used. A substitute power cord should be rated as following

- Current rating 10A
- Voltage rating To match your installation requirement
- Mating connector (AC) IEC 60320 C13 socket
- Mating connector (DC) Either 4mm plug or stripped wire

You should ensure that all cable is routed carefully to protect them from mechanical damage especially those caused by sharp edges.

Each chassis has two separate power feeds, these separately feed slots 4 and 5, as shown below. To fully isolate the chassis BOTH power feeds MUST be removed.



Connector for Slot 5, Rear AC power feed

Ground stud (M4)

Connector for Slot 4, Front AC power feed

Electrical power connection locations for AC chassis



Connector for Slot 5, Rear DC power feed

Ground stud (M4)

**Red** is positive  
**Black** is negative

Connector for Slot 4, Front DC power feed

Electrical power connection locations for DC chassis

### 6.11 Typical redundancy configurations

The chassis configuration below can be used to provide redundant fibre optic links by the use of **ViaLiteHD** chassis, with transmitters, receivers, splitters and switches. Illustrated below are some popular configurations.

For simplicity the chassis configuration is viewed from the rear.

#### 6.11.1 One 1:1 redundant transmitter, standard modules

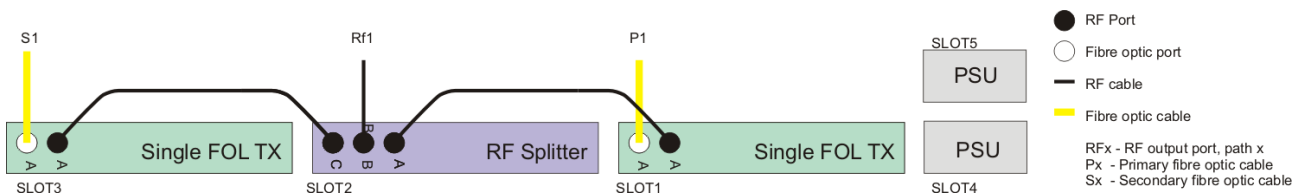

One 1:1 redundant transmitter using standard plug in modules and splitters, viewed from rear of chassis

**6.11.2 One 1:1 redundant transmitter, blindmate modules**

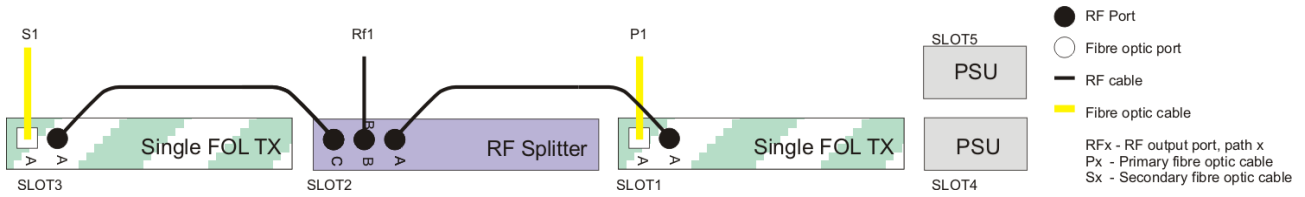

One 1:1 redundant transmitter using blindmate plug in modules and splitters, viewed from rear of chassis

**6.11.3 One 1:1 redundant receiver, standard modules**

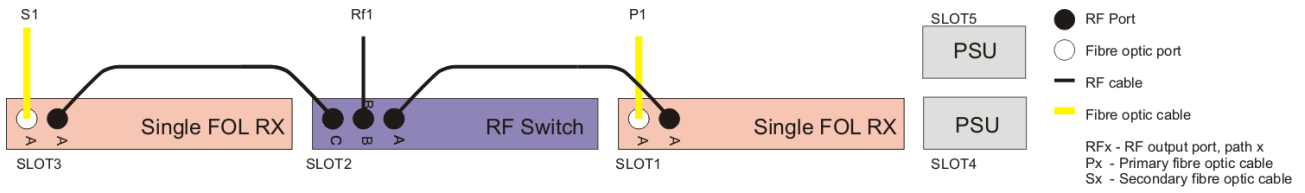

One 1:1 redundant receiver using standard plug in modules and switches, viewed from rear of chassis

**6.11.4 One 1:1 redundant receiver, blindmate modules**

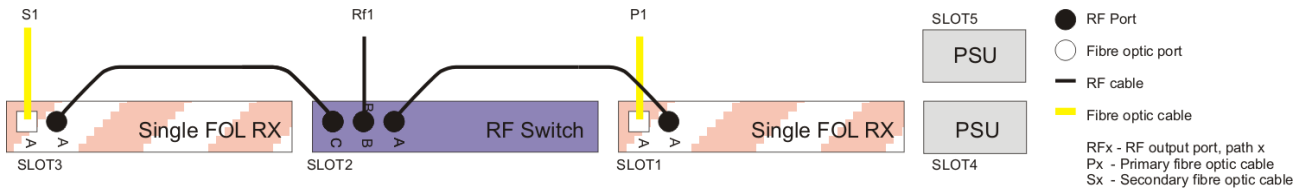

One 1:1 redundant receiver using blindmate plug in modules and switches, viewed from rear of chassis

**6.11.5 One 1:1 redundant link, blindmate modules**

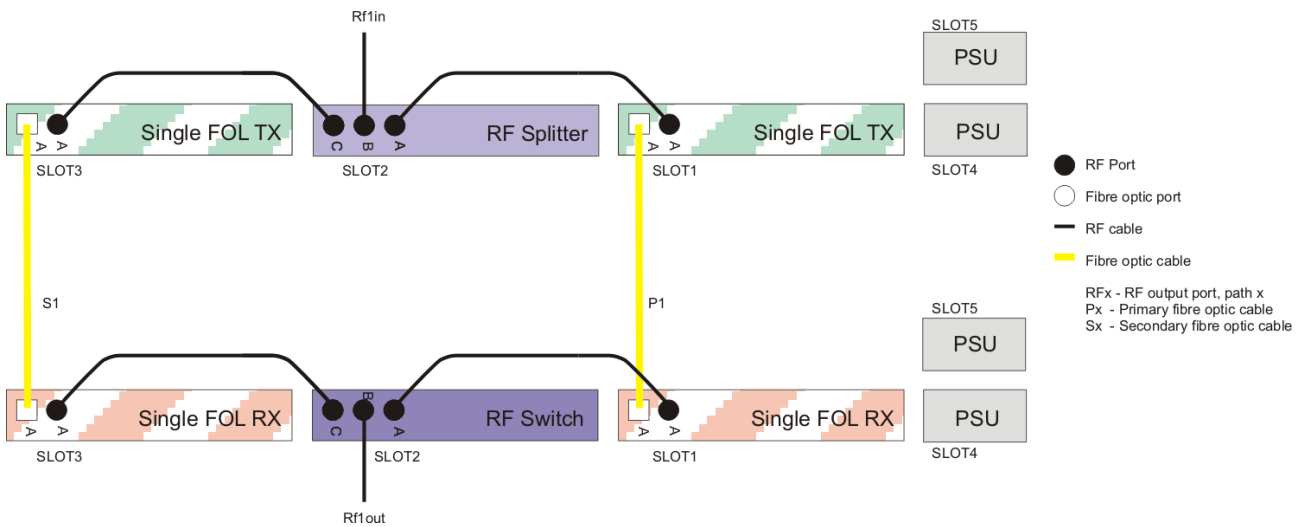

One 1:1 redundant link, blindmate modules, viewed from rear of chassis

6.11.6 One 1:1 redundant link, plus two non-redundant links using dual blindmate modules

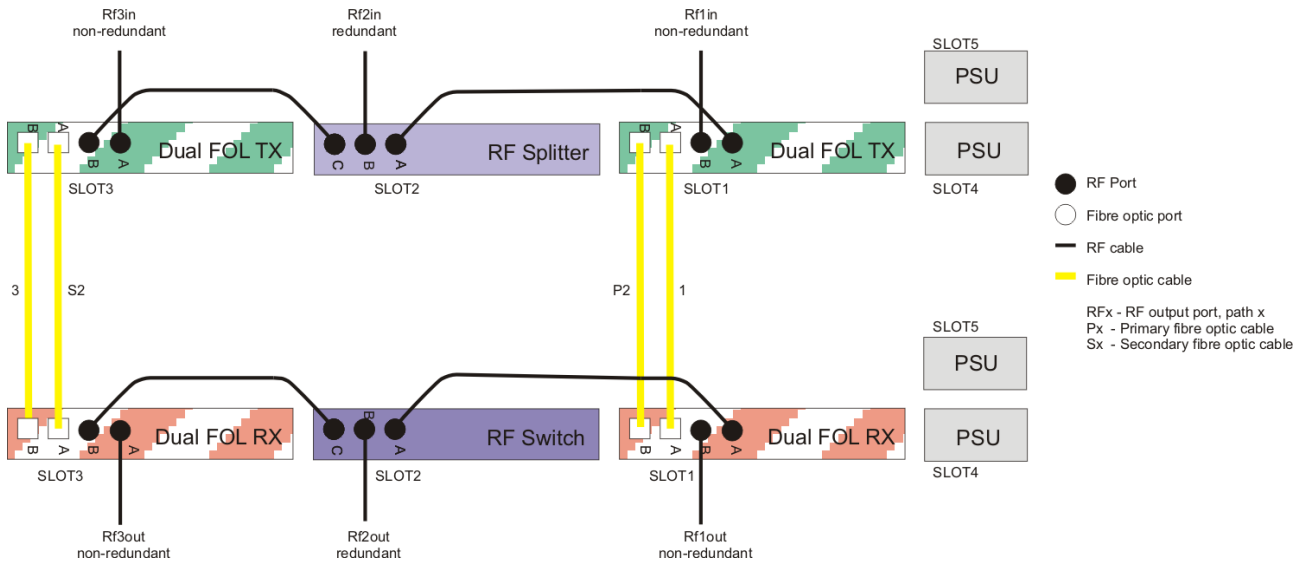

One 1:1 redundant link, plus two non-redundant links using dual blindmate modules, viewed from rear of chassis



## 7 Part Numbering

### 7.1 ViaLiteHD Chassis, part numbering

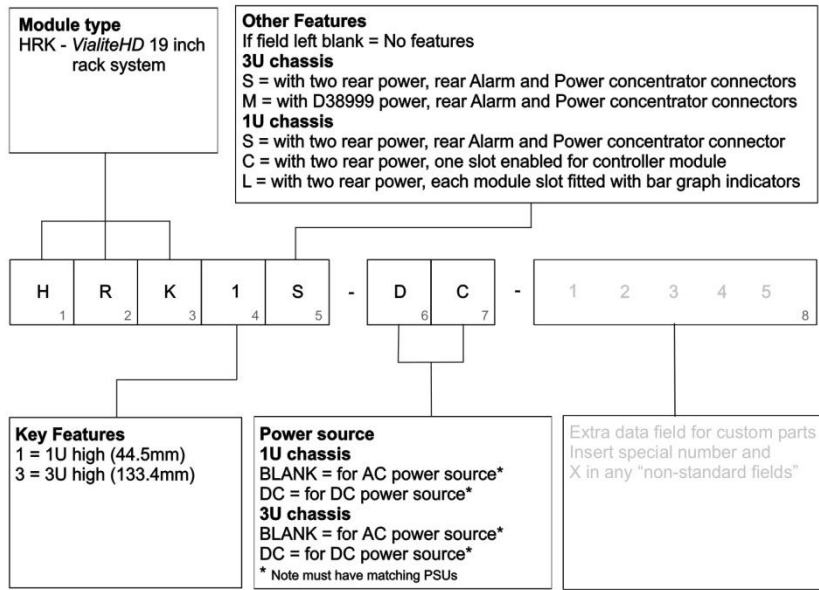

### 7.2 ViaLiteHD Power supply, part numbering

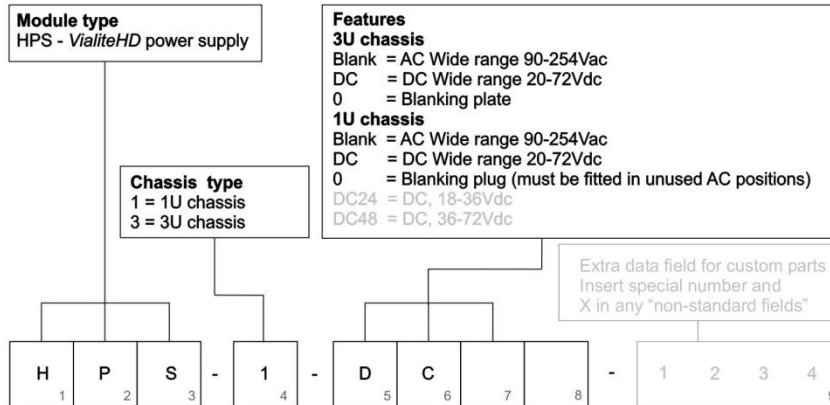

## 8 Maintenance and Fault-Finding Guide

Refer to the following table that gives a list of commonly encountered problems and suggested solutions.

Fault	Possible Causes	Solution
Power LED does not illuminate on the plug-in PSUs.	Power is not connected to the PSU.  Fuse has blown in AC PSU.  Fuse has blown in DC PSU	Connect mains power to the rear of the PSU. Check fuses of power leads.  Return the module to <b>ViaLite Communications</b> or your local agent.  Replace fuse
Power LED does not light.	Power supply is not connected.  Incorrect rack or power supply type	Attach power source.  Check that rack type (AC or DC) matches your power source.  Check that power supply type matches your power source type (AC or DC) and voltage.
Difficulty inserting module.	Incorrect alignment.  Incorrect module slot.	Check that the module is correctly fitted in the card guides.  Check that module is in correct slot HRK1S Slots 1,2 and 3 for 5HP modules Slot 4-5 for PSU modules HRK1C Slots 1 and 2 for 5HP modules Slot 3 for 7 HP modules Slot 4-5 for PSU modules
Summary alarm triggered when no module failure is indicated.	Summary alarm module: Open collector alarms for unused slots not masked.  SNMP and web controller module: Open collector alarms for unused slots not masked.  Failed Module.	Check that the DIP switches on the Summary alarm relay module for all chassis positions are set correctly.  Check the software alarm mask of the SNMP control module for all chassis positions is set correctly.  Return the module to <b>ViaLite Communications</b> or your local agent.

In the event of any problems or queries about the equipment, contact **ViaLite Communications** or your local agent.

For module fault finding information see module handbooks

## 9 Product Warranty

The guarantee / warranty period, unless otherwise agreed in writing, shall be as stated in document F292 - PPM Manufactured Product – Warranty, which is available at: <https://ppm.co.uk/warranty-periods/>. Extended warranty options are available at the time of purchase.

Prior to returning any goods for warranty or non-warranty repairs please contact PPM / **ViaLite Communications** for a returns reference.

## 10 FCC Approval

Information to the user of **ViaLiteHD** products.

For a Class A digital device or peripheral, the following instructions are furnished to the user. This equipment has been tested and found to comply with the limits for a Class A digital device, pursuant to part 15 of the FCC Rules. These limits are designed to provide reasonable protection against harmful interference when the equipment is operated in a commercial environment. This equipment generates, uses, and can radiate radio frequency energy and, if not installed and used in accordance with the instruction manual, may cause harmful interference to radio communications. Operation of this equipment in a residential area is likely to cause harmful interference in which case the user will be required to correct the interference at his own expense.