

86YR Sketch Concepts

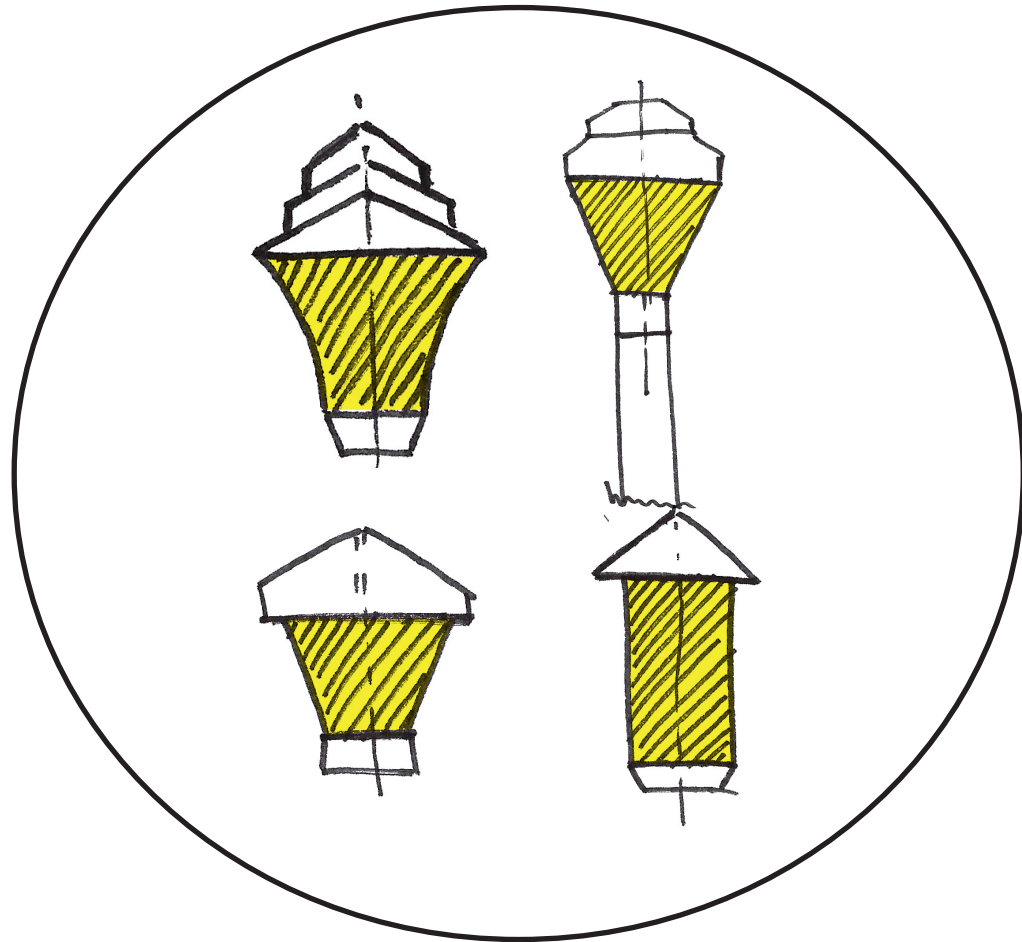

RIGID/ STRONG FORMS

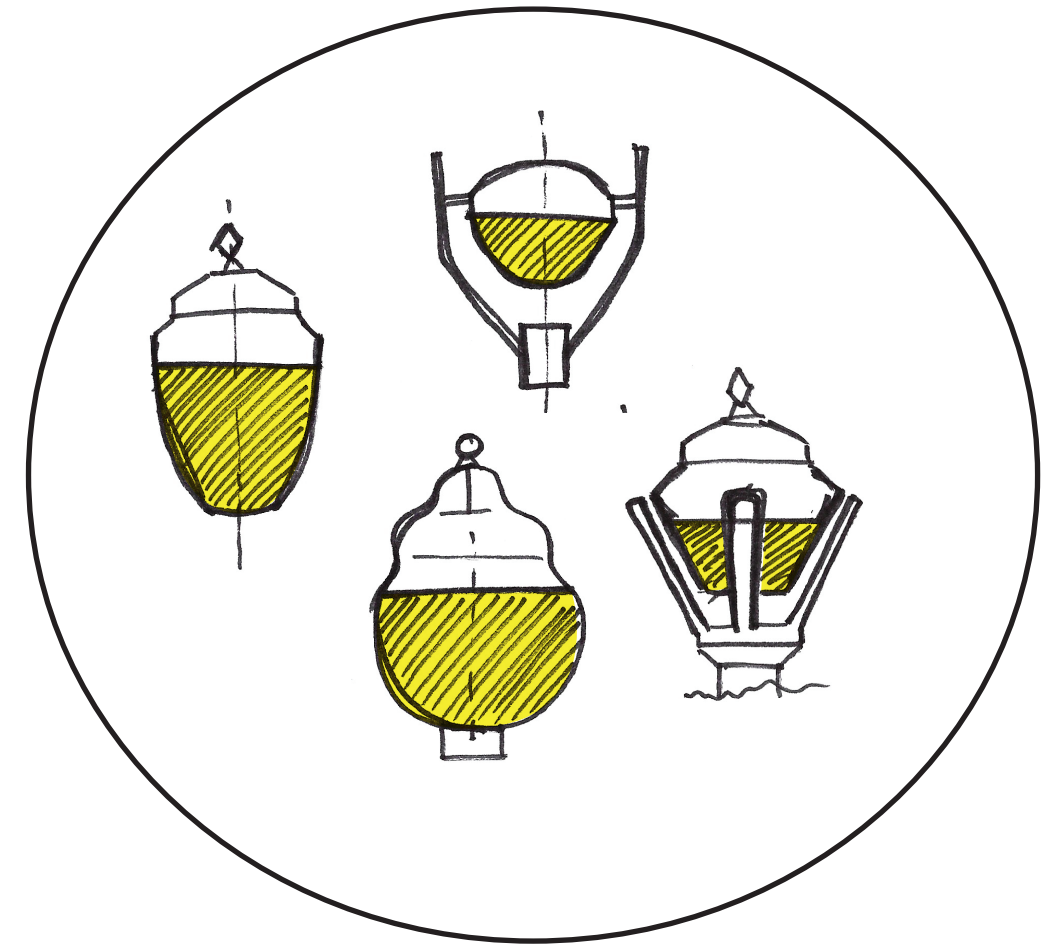

SOFTER/ BULBUS FORMS

86YR Sketch Concepts

CIRCULAR AND SOFT? OR
SQUARED, HARD EDGES? OR
SOMETHING IN BETWEEN?

TOP PROFILES:

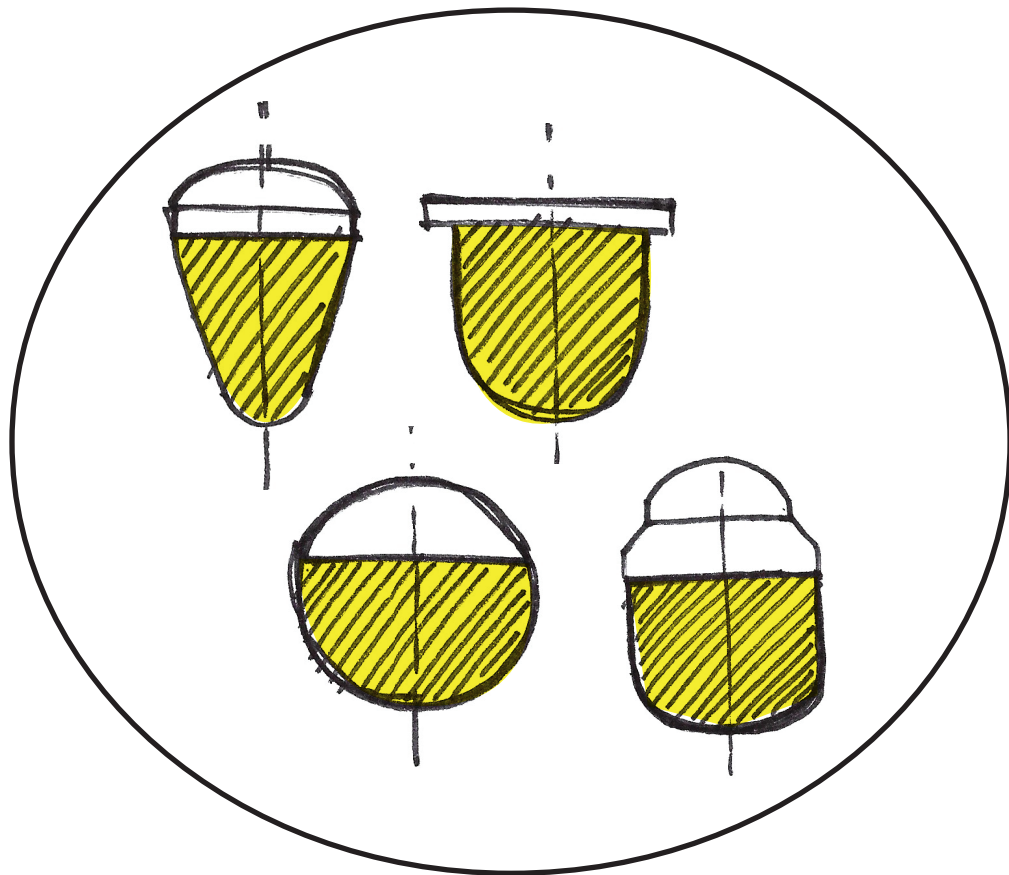
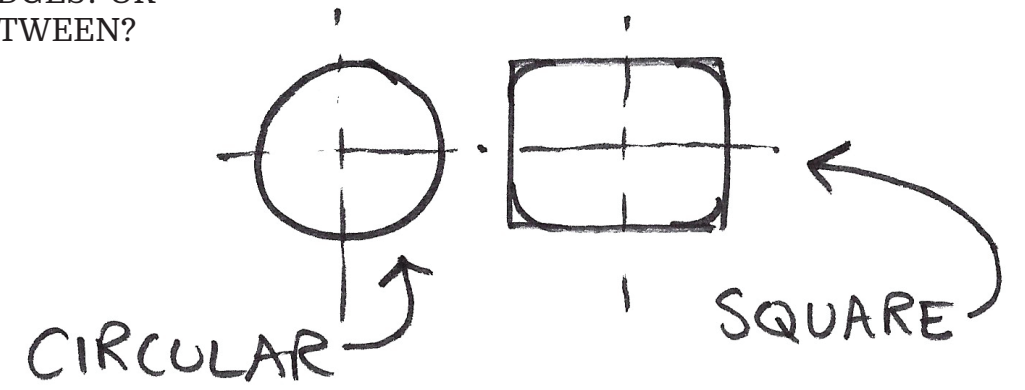

ROUNDED/ SEAMLESS FORMS

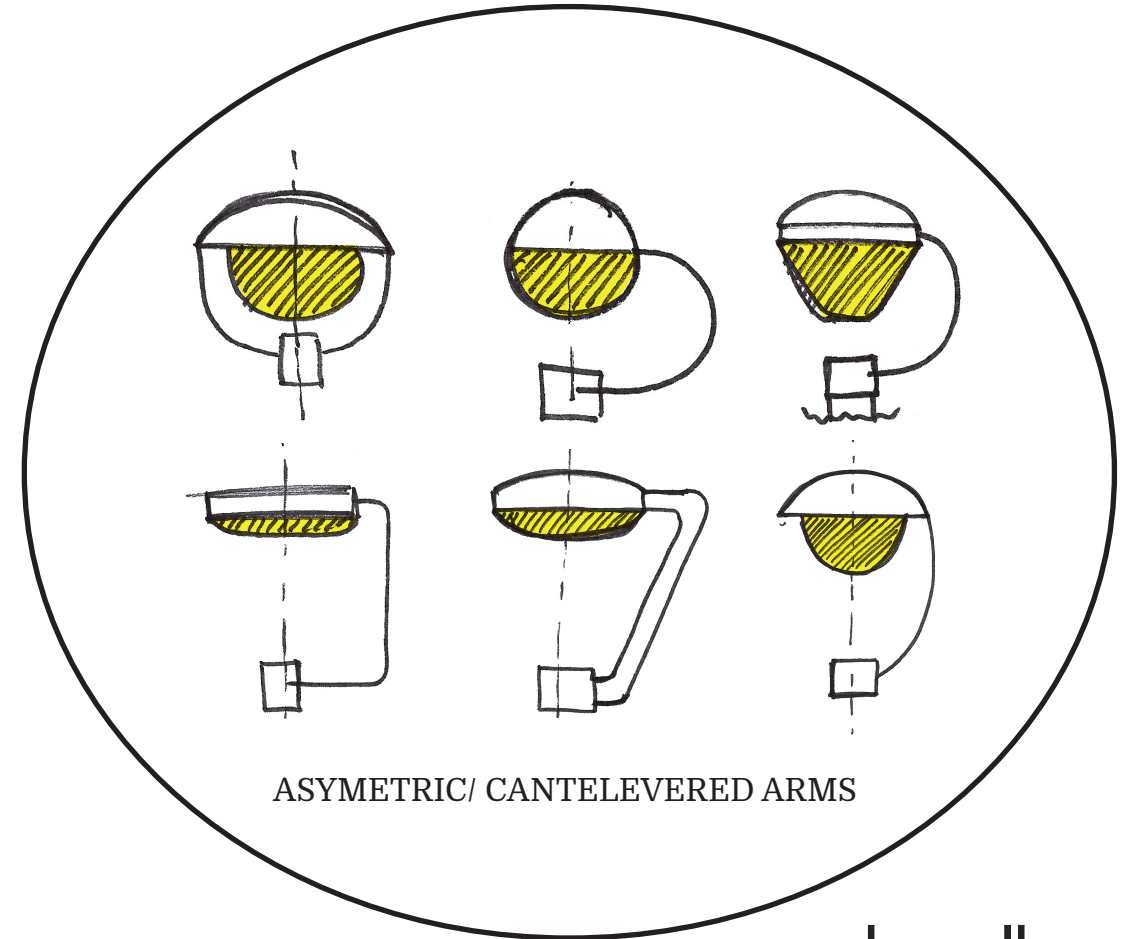
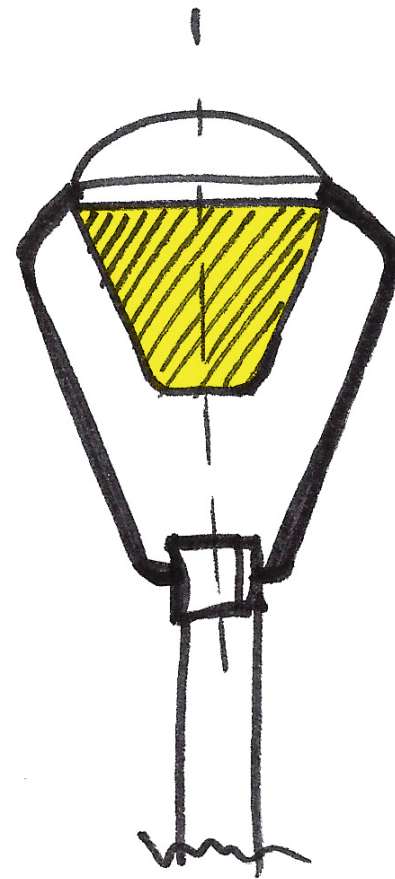

ASYMMETRIC/ CANTELEVERED ARMS

86YR Sketch Concepts

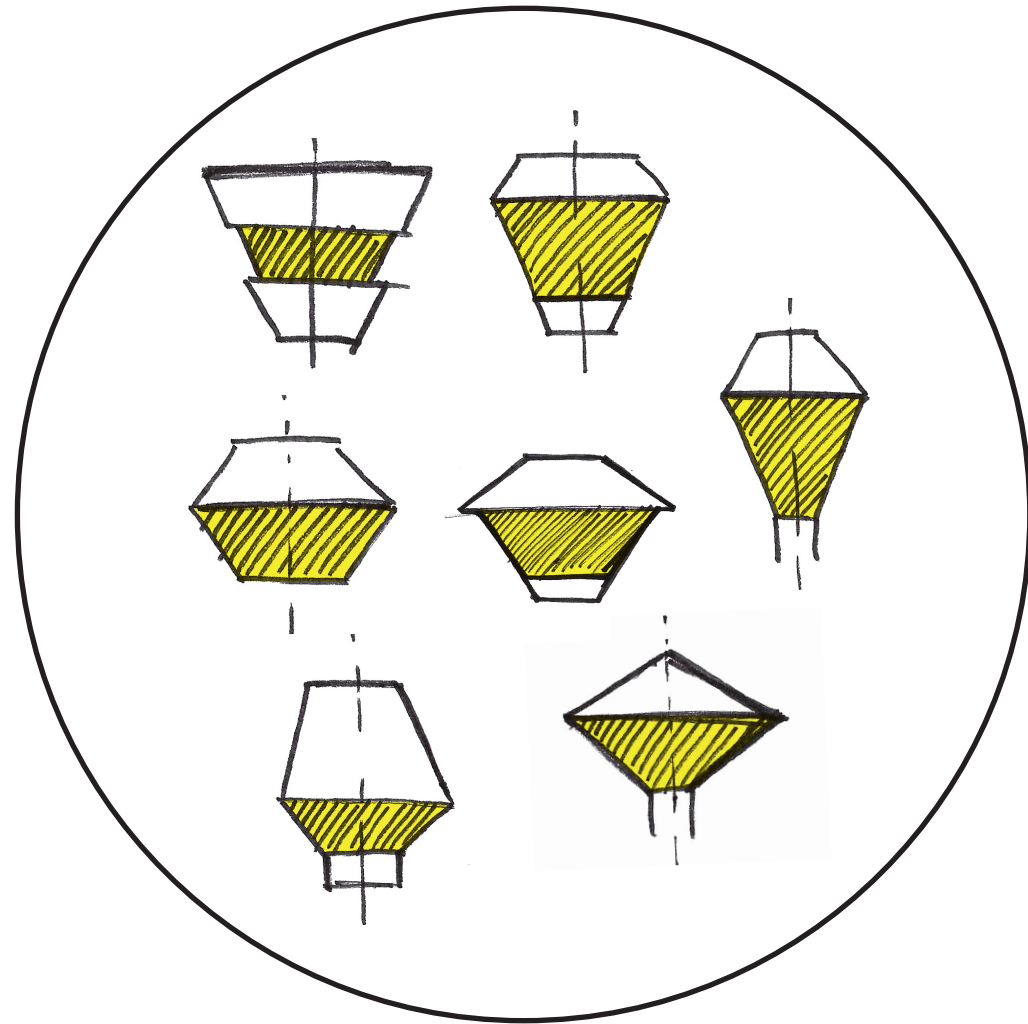

GEOMETRIC FORMS/ HARD EDGES

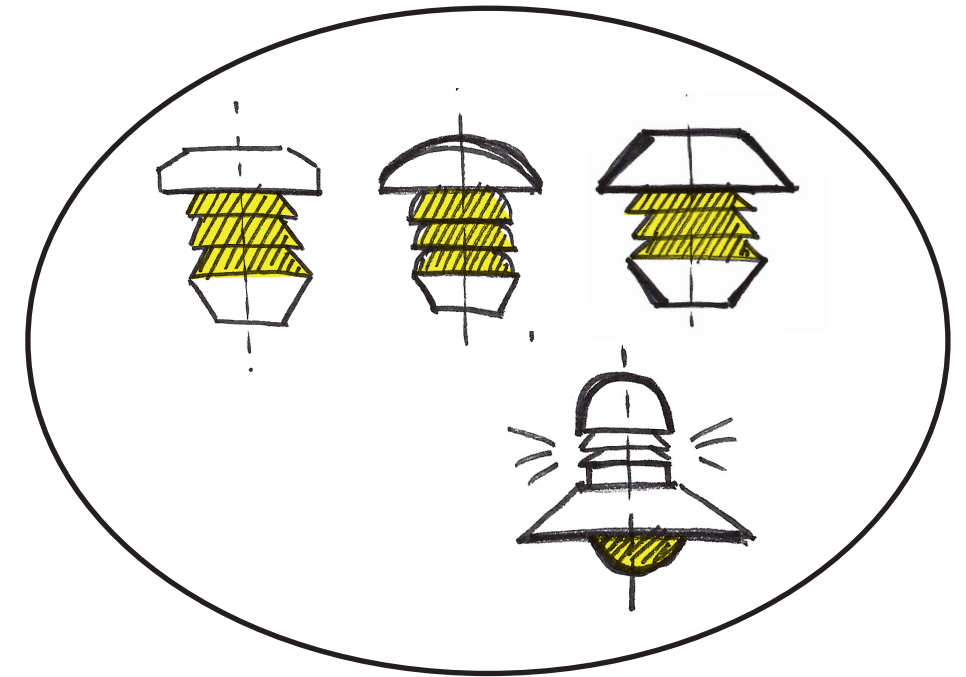
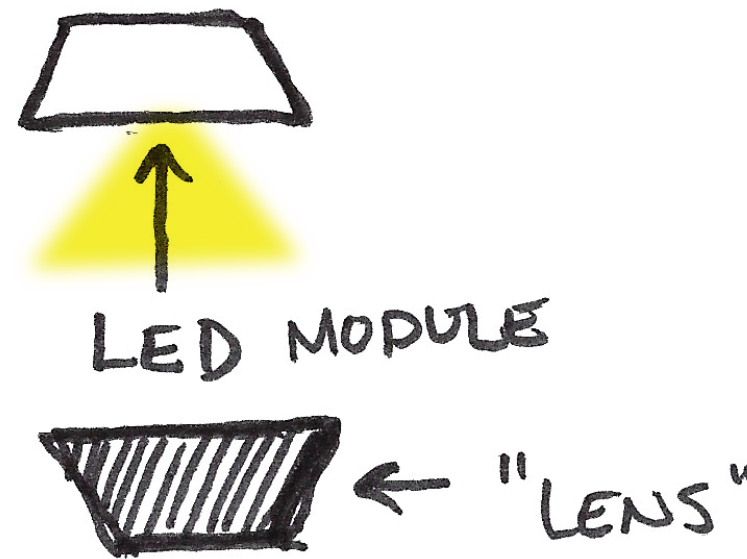

REPEATED SHAPES
WITHIN FORM

86YR Sketch Concepts

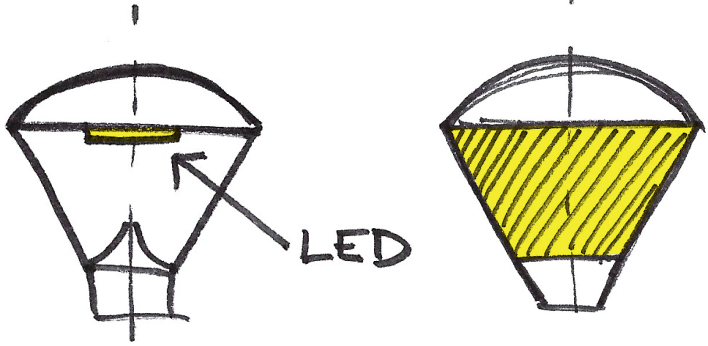

LED

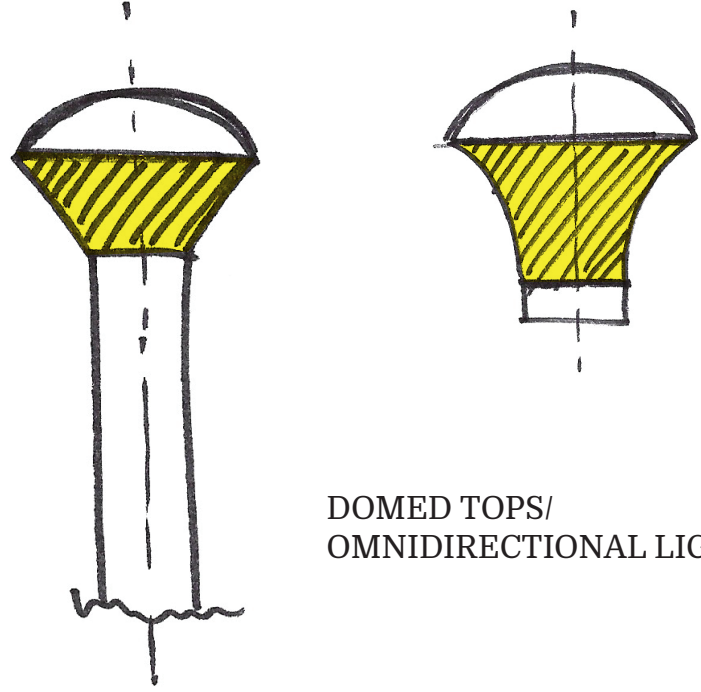

DOMED TOPS/
OMNIDIRECTIONAL LIGHT OUTPUT

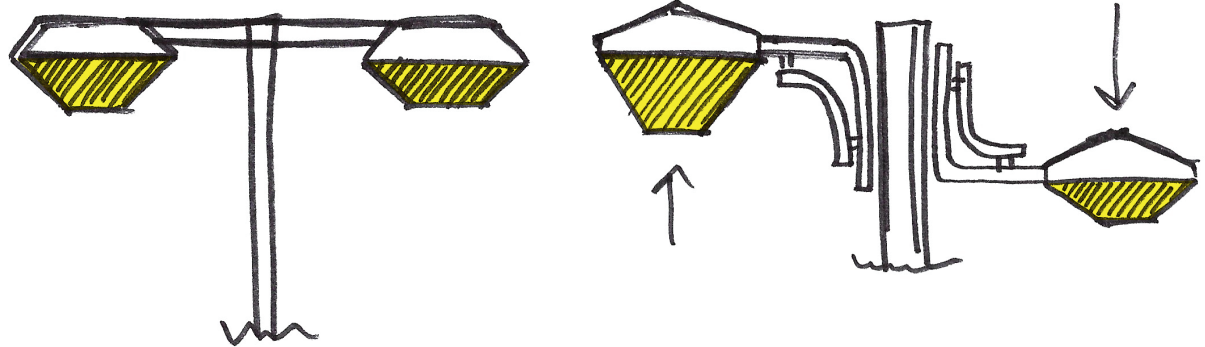

ARM OPTIONS. HOW DO WE WANT
LIGHT TO ATTACH TO POLE?

SUROUNDING ARMS?

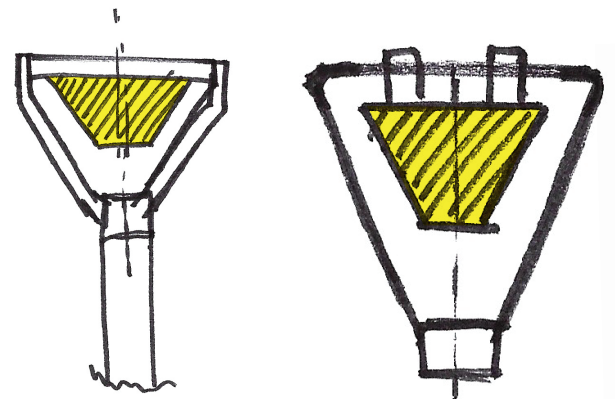

CENTER POST?

