



### RYCO STRAIGHT CUT FISH HEADER: ACCURATE, RELIABLE, & SAFE

*This machine was originally designed to process large Cod and similar fish. Fish such as Yellow Fin Sole, Rockfish, Pollock, and even Salmon have been successfully processed with this machine.*

*With the large 17" diameter blade, fish up to 6.5" thick can be cut. There is no limit to the width or length of the fish, except that the length of the removed head may not be greater than 12".*

*The machine can be adjusted with two change parts to accurately cut fish as thin as 1/2". With the addition of a second blade, Yellow Fin Sole can be cut into 3" wide Kurimi product.*

*The machine may be fitted with either a vacuum attachment or a low pressure water nozzle to wash out the visceral cavity. The water nozzle is very effective in cleaning the viscera from Kurimi.*

*Fish are manually placed on the lower infeed belt in the correct cutting position as indicated by a reference slot below an indicator. The belt transports the fish automatically into the machine where they are gripped by an overhead belt and moved under the 17" diameter blade for an accurate, straight cut.*

*The heavy stainless machine frame is carefully designed for easy installation and maintenance. Shaft bearings are standard lip sealed ball bearings in brass bodies. Chains and shafts are stainless, rolls are delrin, gears are brass. Fish belts are V-belt backed for positive tracking.*

*There are no mild steel parts except the drive motor and valves. There are no aluminum parts in the machine.*



*Extended Infeed Version Shown*

#### **FEATURES:**

- Will cut over 80 fish per minute
- Cuts half pound Sole
- Cuts 20 pound Cod
- Double cuts Kurimi
- Heavy duty construction and non-corroding components suitable for remote locations and aboard ship

#### **UTILITIES:**

- Electric: 2kw, 3 phase
- Water: fresh or salt, 1gpm, 50psi

#### **OPTIONS:**

- Variable speed hydraulic drive

**SPECIFICATIONS MAY CHANGE – CONTACT RYCO FOR SPECIFIC APPLICATIONS**

Address: 6810 220<sup>th</sup> Street SW  
Mountlake Terrace, WA 98043 – USA

Phone #: 425-744-0444  
Fax #: 425-673-2666

Web: [rycous.com](http://rycous.com)  
E-mail: [sales@rycous.com](mailto:sales@rycous.com)

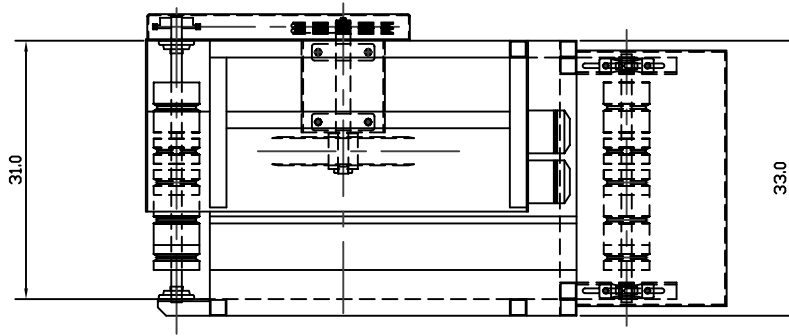

PLAN VIEW

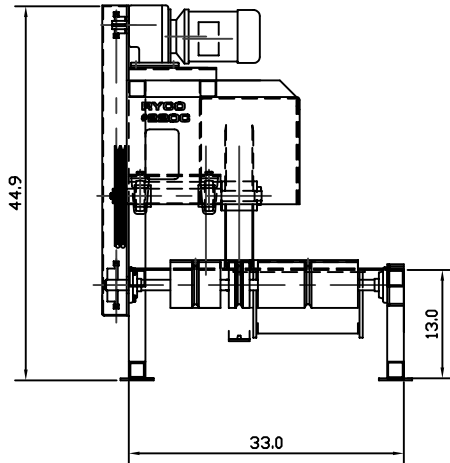

OUTFEED ELEVATION

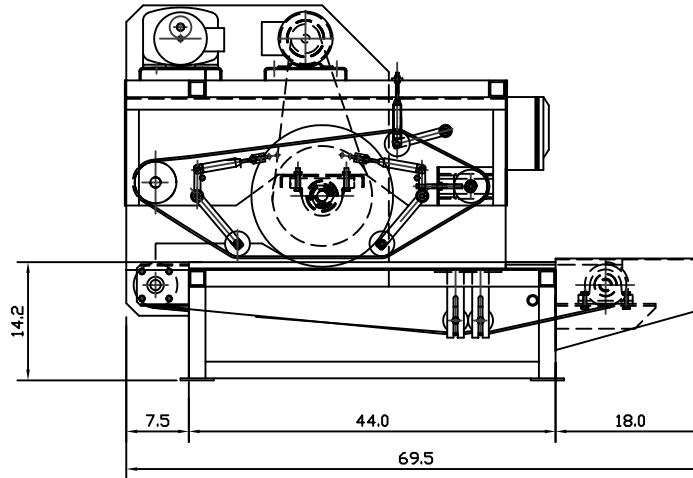

SIDE ELEVATION

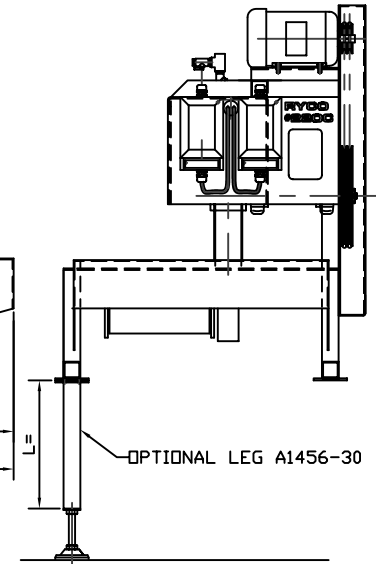

INFEEED ELEVATION