



USER MANUAL



Edition 01-2020



Designed, Engineered, and manufactured in Italy

WARNINGS	4
WHAT IS ASSISTED PEDALLING?	5
BASIC INFORMATION	6
Description of the contents.....	6
Legal requirements.....	6
For your safety	6
10 rules for riding safely.....	6
Warranty terms.....	7
Travelling range of a pedal assisted cycle.....	8
Who can ride your e-bike?.....	8
Electric assisted pedalling.....	9
Physical and mental fitness	9
RESIDUAL RISKS	10
Fire.....	10
Electrical Risks.....	10
Never use the battery charger and pull out the plug immediately if:.....	10
TECHNICAL DATA	11
components.....	11
MAIN COMPONENTS	12
REMOVING AND INSTALLING THE SUPPORT	15
BEFORE SETTING OFF WITH YOUR BICYCLE	15
Before each use.....	15
CHECKLIST OF CONTROLS TO PERFORM BEFORE EACH USE	16
Checking the wheel units.....	16
Checking the seat and the seat post	17
Checking the handlebars and handlebar stem	17
Checking the brakes.....	18
Checking the side stand	18
GENERAL USE	20
General summary of Federal and local regulations governing e-bikes, and warnings regarding adjusting the speed limiter.....	21
Ital E-Bike speed limit.....	21
ADJUSTMENTS	22
Ideal height of the saddle.....	22
Adjusting the horizontal position of the saddle	22
Adjusting the saddle height	23
Adjusting the suspension forks (if equipped).....	23
Handlebar adjustment	24
Adjusting the brake levers.	25
CONTROLS ON THE SIDE RIGHT OF THE HANDLEBAR	26
USING THE DISPLAY	27
Functional overview	27
Start screen.....	27
Home screen.....	28
Settings screen.....	29
DEFINITION OF BUTTONS	29
OPERATION	29

How to turn your Ital E-Bike on and off	29
Password to turn on	30
Selecting assist modes.....	30
Speed, mileage, trip data.....	31
Walk assist mode.....	31
Headlight on/off(day and night mode switch)	32
Battery level.....	32
current power usage	33
USER SETTINGS	33
Settings screen.....	33
Exit item	33
Setting the units	34
Setting the display backlighting.....	34
Setting the clock.....	34
Setting the password.....	35
Setting the automatic shutdown time	36
Setting the wheel diameter	37
System information review	37
Resetting factory settings.....	38
DATA CLEARANCE.....	39
ERROR INFORMATION	40
HOW TO ACTIVATE THE Ital E-Bike anti theft system.....	41
Locking the rear wheel.....	41
THE BATTERY	42
Useful information about the battery.....	42
The Ital-Ebike battery.....	43
Battery technical data	44
Removing and installing the battery.....	44
Lock for assembly and taking apart of the battery.....	45
Removing the battery.....	45
Installing the battery	46
How does the Ital E-Bike battery perform during use	47
Battery life.....	48
Charging the battery.....	49
Instructions for recharging	49
Caution	49
How to use the battery charger	51
Warnings	51
Characteristics of the battery charger	51
GEARBOX F8.11.....	52
Introduction	52
Upshifting	53
Downshifting.....	53
MOTOR	54
Caution	54
Adjusting assistance Level.....	54
MAINTENANCE AND CARE	55
WASHING.....	56
PUTTING THE BICYCLE in storage	57
Preparation of the bicycle for a long period of storage	57
Recycling	57
Caution:	57
DISPOSAL OF YOUR Ital E-Bike	57
QUESTIONS AND ANSWERS.....	58

Congratulations on choosing Ital E-Bike

Warning, Read this manual carefully and follow the instructions below.

- This is a pedal assisted cycle.
- It is not a toy, do not allow it to be used by children.
- Keep the user and maintenance manual in a safe place.
- Ride safely.
- Do not use in the event of snow.
- Never ride standing.
- Never ride with only one hand.
- Observe road and traffic regulations.
- Avoid riding up or down very steep hills.
- Do not brake and pedal at the same time.
- Only use the battery supplied.
- Only use the battery for its intended purpose.
- To charge the battery, only use the supplied battery charger.
- Charge the battery in a well ventilated area.
- Do not attempt to repair the battery or battery charger.
- Do not insert objects into the battery charger and do not expose the battery charger, the battery or the electrical components, to water or other liquids.
- Do not throw away used batteries: they can seriously damage the environment.
- When replacing batteries, contact your dealer.
- Avoid using accessories sold by unauthorized dealers, they could cause harm to people and the structure of the bicycle itself.
- Consult qualified staff regarding all routine maintenance and repairs.
- Do not wash the bicycle with a high-pressure jet. A powerful water jet can damage the electrical components of the bicycle. In which case the warranty will be rendered null and void.
- Inappropriate use represents a danger to the user and others. Moreover, in the case of inappropriate use, the warranty will be rendered null and void.

WHAT IS ASSISTED PEDALING?

This bicycle is equipped with an electric assisted pedaling system. **An electric motor assists the effort made by the cyclist.** To activate the assist it is necessary to begin pedaling and impart force on the pedals, and consequently the torque sensor. Conversely, if the rider does not pedal, the motor remains inactive. Four different levels of assist are available. The assist modes are selected using a control on the left handlebar.

When the assisted pedaling is activated, starting from standstill is much easier and more immediate. Therefore, before using this bicycle in traffic, it is necessary to learn how to use it so as to avoid any surprises when setting off.

When the bicycle is stopped, it is recommended to use the "ECO" assist mode when setting off in order to avoid accidental falls.

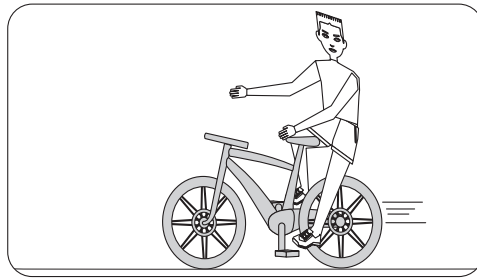

When the assisted pedaling is switched off, the bicycle will require additional pedaling force. The Ital E-Bike is equipped with an electronic gear change system. Reserve power is stored in the battery to allow this system to function provided the bike is turned on.

By law, class one e-bikes can not assist pedaling after 20 mph, therefore, once 18 mph has been reached, the assisted pedaling decreases gradually before completely turning off at 20 mph

The range of the bicycle depends on the user, the circumstances and the type of route. Main factors affecting the operating range are: weight of the rider, cruising speed, slope of the route, tire pressure, wind direction, number of gear changes and braking (in the city) and outside temperature. Very low temperatures adversely affect the operating range. It is important to take this into account.

BASIC INFORMATION

DESCRIPTION OF THE contents

- E-bike complete with pedals and wheels
- Support for transport, which can be used in a vehicle
- Battery charger
- Instruction manual.

LEGAL REQUIREMENTS

Every road user must follow the traffic regulations in force in their country. To ride an e-bike, make sure that permits or a driver's license are not required by the authorities. In many countries it is possible to travel on public streets and roads provided that additional equipment is used as prescribed by law, such as signalling lights, clothing with reflective strips and a helmet.

FOR YOUR SAFETY

Make sure that your dealer has completed the necessary sections of the warranty, and that you have received all the documents supplied with the bike, in this manual.

- Contact your dealer if you detect omissions or oversights.
- Use your Ital E-Bike only after you have carefully read the following user manual, inside you will find important information.
- If you choose to sell or give away your e-bike, also give this manual to the new owner.

10 RULES FOR RIDING SAFELY

- 1 - Do not turn the key while riding.
- 2 - Inspect the bicycle if you hear abnormal noises while riding. If necessary, contact an authorized Ital E-Bike Service Centre.
- 3 - To ensure proper operation of the bicycle, and for added safety, we recommend that the bicycle be used by a single person.
- 4 - Do not overload the bicycle or carry objects that may obscure vision.
- 5 - Do not drink while riding.
- 6 - Make sure that the bicycle is upright before starting to pedal, so as to avoid falls.
- 7 - To avoid personal injury or accidents do not pedal with only one foot
- 8 - Do not pedal hard on a downhill road when the motor power is decreasing.
- 9 - If it is raining, do not ride with an open umbrella.
- 10 - Do not touch the motor after using the bicycle, as it could cause burns.

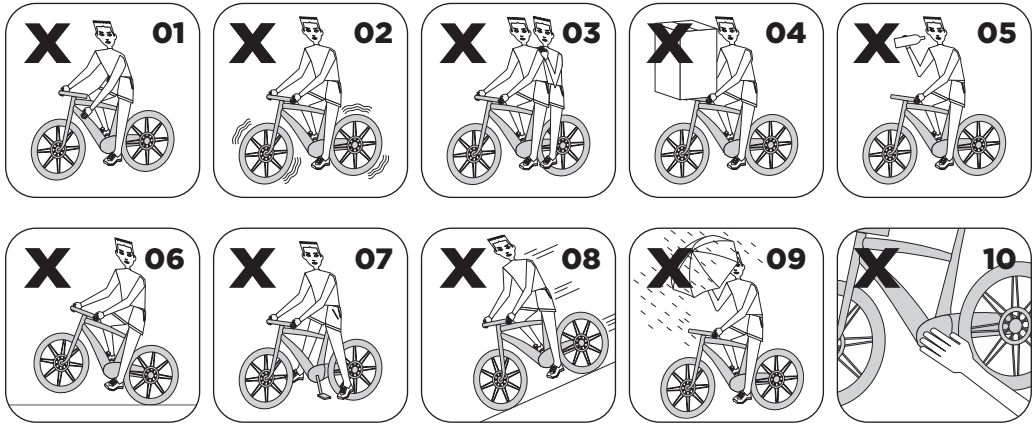

WARRANTY TERMS

The durability and reliability of the bicycle, as well as the warranty coverage, are valid only if the customer complies with some basic rules:

- The use of the e-bike for anything other than the intended design may result in dangerous situations, falls and accidents. Short circuiting may also occur inside the battery pack causing damage or injuries to the user.
- Always use your e-bike as described in this instruction manual and in any supplementary documentation.
- Improper maintenance or repairs can cause damage and compromise the safe operation of the e-bike. This can give rise to dangerous riding situations, falls and accidents.
- The user can only perform work on the e-bike that is described in this instruction manual, as these operations can be performed by the user provided suitable tools are available.
- It is not permitted to change the characteristics of the individual components of the e-bike.
- All other work, including preparation for use, can only be performed by an Authorized Ital E-Bike dealer.
- Never add equipment or try to make alterations to your e-bike by yourself.
- You can request additional accessories through your Ital E-Bike dealer
- You should only ride and use an e-bike if you are in perfect physical and mental shape.

TRAVELLING RANGE OF A PEDAL ASSISTED CYCLE

The Range of an e-bike is dependent on several factors. The electric motor will absorb more power with increased weight and when climbing hills, riding against the wind, stopping and starting repeatedly and changing gear, thereby reducing the distances that can be traveled.

A light rider could travel 50 - 60 miles over flat terrain, if using a low level of assist. However a heavier rider traveling up a 7% grade in race mode may only have a 15 mile range.

It is **important to note** that the motor works at peak efficiency and will consume less battery power for the same torque output when the rider pedals with a **smooth and consistent** cadence of 70 - 80 rpm. By optimizing pedaling and gear position, a skilled rider can learn to optimize range

Instantaneous power consumption is shown as a bar graph at the bottom of the display screen (**fig 1**)



WHO CAN RIDE YOUR E-BIKE?

- The rider must be able to ride a bicycle, i.e. they must have a basic knowledge of using bicycles with the necessary sense of balance to ride and control a bicycle.
- The rider, from a stationary position, should be able to get on and off safely and must be able to touch the ground with their feet. Children are not permitted to ride the Ital E-Bike

ELECTRIC ASSISTED PEDALLING

Ital E-Bike is equipped with an electric assisted pedaling system. Assistance may be set to one of 5 modes (Fig. 1):

OFF (No assist)
ECO
LOW
HIGH
RACE

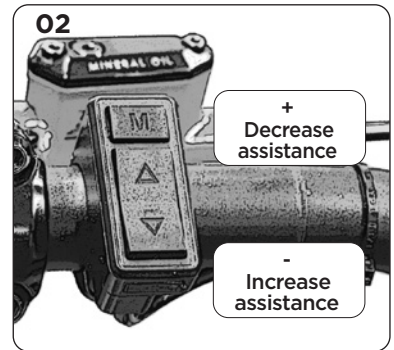

The modes can be selected any time the bike is turned on by pressing the **▲▼** buttons on the left side of the handlebars.

PHYSICAL AND MENTAL FITNESS

If the rider wishes to ride a bicycle along public streets and thoroughfares, they must be physically and mentally able to circulate with the traffic on the roads.

The e-bike is not designed to compensate weakness or a lack of fitness.

RESIDUAL RISKS

FIRE

Only keep the e-bike in rooms with ambient temperatures between 15°F and +100°F.

KEEP THE E-BIKE AWAY FROM HEAT SOURCES SUCH AS RADIATORS, HEATERS, STOVES, ETC.

IN THE EVENT FLAMES OR SMOKE EMERGE FROM THE BATTERY PACK, IMMEDIATELY STOP THE BIKE. PROCEED TO PUT OUT THE FIRE WITH A FIRE EXTINGUISHER, IF AVAILABLE.

ELECTRICAL RISKS

As a result of faulty, damaged or defective battery chargers and power cables, you may suffer potentially lethal electrical shocks.

An incorrectly charged or stored battery can catch fire.

To recharge the Ital E-Bike's battery pack, only use the battery charger supplied.

Keep the battery charger away from people and animals.

Do not allow the battery charger to come into contact with water or other liquids.

Do not charge the battery pack in direct sunlight.

Keep the battery pack and battery charger away from sources of heat (such as radiators).

Only charge the battery while present and in a ventilated place (garage).

Unplug the Battery charger immediately if:

If the battery charger has any kind of damage.

If the cable insulation or one or more plug connections are damaged. In this case, only hold the plug at an insulated point. If necessary, disable the corresponding fuse in the electrical distribution box.

If the battery charger heats up in an unusual way. However it is normal for the battery charger and the accumulator to heat up slightly.

TECHNICAL DATA

Gearbox	Ital E-Bike 8 speed electric with rotary gear selection
Gear shifters	Electrical with a microswitch on the handlebars
Gears	8 sequential
Motor	Ital E-Bike FL80S 48 V 500 Watts
Torque sensor	Ital E-Bike technology for detection load
Battery	Ital E-Bike 48Volt 10.5 Ah (504 W/H) lithium-ion battery
Display	Ital E-Bike 3.5" LCD with backlight and multifunction
Anti-theft	Mechanical key for total locking of the rear hub
Anti-theft	Electromechanical with movement deactivation via PIN code
Range	50/60 m (depending on the assistance and the type of route)
Assisted speed	Maximum of 20 mph

Components

Frame	Ital E-Bike in hydroformed aluminium
Seatpost	Ital E-Bike L.300 Matt Black
Brakes	Hydraulic
Rims	Ital E-Bike in aluminium 26", 27.5" or 28" (depending on model)
Handlebars	Ital E-Bike in Matt Black aluminium
Handlebar stem	Ital E-Bike fixed or adjustable Matt Black
Front fork	Ital E-Bike fixed or suspension (depending on model)
Tires	Schwalbe or Vittoria (depending on model)
Weight	46/55 lb (depending on model)

MAXIMUM LOAD CAPACITY OF 250 lb

MAIN COMPONENTS

1. Display
2. Battery closing
3. Battery
4. Battery charger socket
5. Electronic control unit box
6. Gears and motor
7. Single arm fork
8. Kickstand
9. Saddle
10. Seatpost
11. Saddle lock
12. Crank
13. Pedal
14. Wheels
15. Frame
16. Braking system
17. Fork
18. Lights, if provided

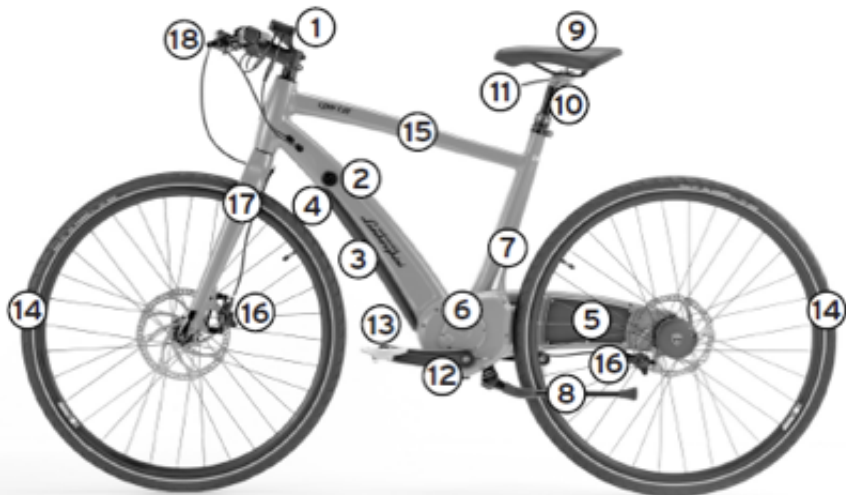

REMOVING AND INSTALLING THE SUPPORT

This special support for your Ital E-Bike is provided with each bike and can be used for easy transport of your Ital E-Bike by vehicle

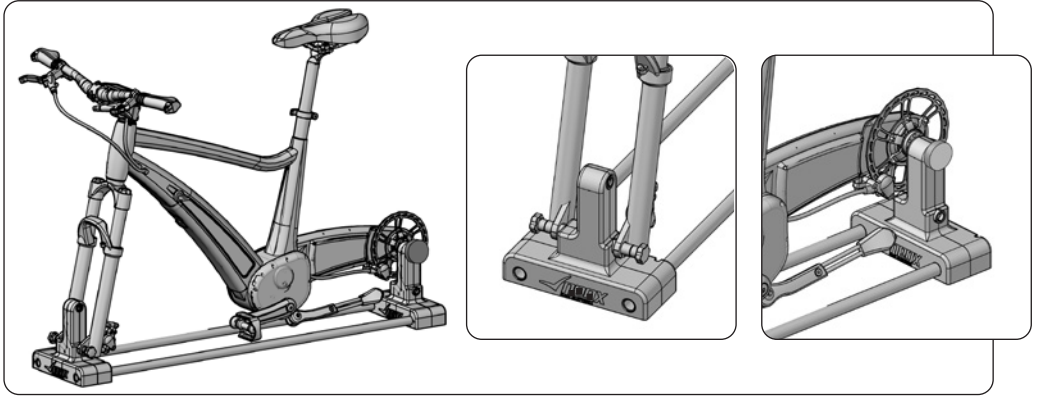

BEFORE SETTING OFF WITH YOUR BICYCLE

Be careful whenever you are riding a bicycle, there is a danger of serious falls and accidents, especially if road surface or weather conditions are not ideal. Your e-bike is delivered to your dealer assembled. For safety purposes, some important components are not completely assembled. Your dealer should perform the final assembly of your Ital E-Bike, making it safe.

- Only use your e-bike in a suitable sitting position.
- Ask your dealer to adjust the saddle height so that it is in the correct position for you.
- Ask your dealer to instruct you about the technical features of your Ital E-Bike.
- Treat your e-bike with spray wax.
- **FULLY CHARGE THE Battery - THE FIRST 5 TIMES OF USE ENSURE THE BATTERY IS COMPLETELY FLAT BEFORE RECHARGING.**

BEFORE EACH USE

A bicycle that is not safe can give rise to dangerous riding situations, falls and accidents.

- Before every ride, check that it is able to operate safely.

- Stop and inspect the proper set up of your newly purchased bike, so as to more easily recognize any anomalies at a later time
- If any defects are detected during these inspections, immediately contact your dealer.
- You can use your bike again only when it is safe.

Before each check, make sure that your bike is switched off and is not connected to the power supply, so that you do not inadvertently start it.

CHECKLIST OF CONTROLS TO PERFORM BEFORE EACH USE

CHECKING THE WHEEL UNITS

- Check that all the parts are properly mounted.
- The hub of the wheel assembly should not move on the front fork or rear monoarm.
- The quick release lever on the front wheel must be closed and the closing knob on the rear wheel must be fixed and with the security lock closed.
- check the fixing of the security bolt (A) on the closing knob.
- Check the tire pressure.
- Check the position of the valve which must be perpendicular with respect to the rim and not tilted.
- Verify the absence of external damage, foreign bodies and wear on the tires:
- The entire surface of the tire must still have the original tread pattern.
- It should not be possible to see the section of the tire that is located under the layer of rubber.
- There should be no dents, cracks, cuts or damage.
- Remove any foreign bodies (thorns, small stones, bits of glass, etc.) by hand or using a small tool without spikes or blades.

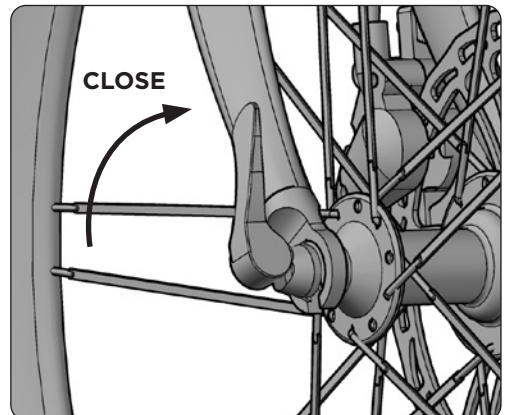
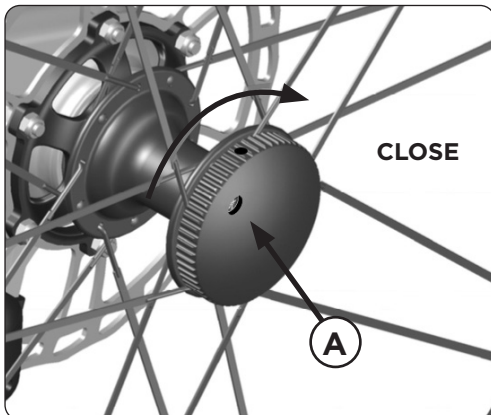

With greater load on the bike, tire pressure should be increased, however do not exceed the maximum pressure marked on the tire.

CHECKING THE SEAT AND THE SEAT POST

If the seat post is not inserted deep enough into the frame, it could separate from the frame while riding and lead to dangerous riding conditions, falls and accidents.

- Make sure the seat post is inserted at the correct depth.
- Hold the saddle firmly with your hands and try to turn both the saddle and the seat post inside the frame.
- The saddle and the seat post must not move.
- If the saddle and/or seat post move they must be suitably fixed

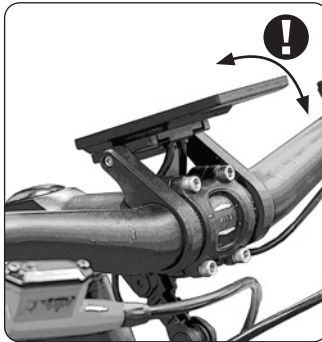
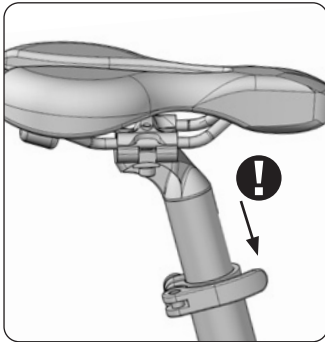

CHECKING THE HANDLEBARS AND HANDLEBAR STEM

If the handlebars and handlebar stem are not fitted properly or are damaged this can lead to dangerous riding conditions, falls and accidents.

- If you detect defects in these parts, or if you have doubts about them, immediately stop using your Ital E-Bike.
- Perform a visual inspection of the handlebars and handlebar stem.
- The stem must be parallel to the front wheel rim and the handlebars must be in a perpendicular position.
- Clamp the front wheel between your legs.
- Grip the handlebars at both ends.
- Firmly try to turn the handlebars in both directions.
- Again with force, push down with your hands and try to turn the handlebars in the stem.
- No part must move or shift.
- You should not hear squeaks or creaks.
- Tighten according to the torque marked on the parts (Nm).

CHECKING THE BRAKES

Faulty brakes can cause hazardous riding conditions, falls and accidents. **Mal-functioning brakes could be life threatening.**

- Check your braking system with particular attention.
- During everyday use the discs and the brake pads wear out diminishing their braking power. They must be replaced periodically.
- Apply the brakes and try to move the bike, both wheels must stay locked.
- Dirty brake discs must be cleaned immediately.
- The presence of oil and grease on the brake discs can reduce the braking power and lead to dangerous riding conditions, falls and accidents.
- Check that the brake disc is not damaged. It must be free of nicks, cracks, deep scratches and any other mechanical damage.

CHECKING THE SIDE STAND

Riding with the stand down can cause serious falls. The same applies if the stand opens by itself during travel.

A side stand which is bent, too short or too long can not guarantee the stability of your bike which could later fall, injuring you or other people.

- Repair or replace the stand at an Ital E-Bike Service Centre, if it is bent.
- Side stands with adjustable length should be adjust to the right length so that your e-bike is stable.
- Perform a visual inspection of the screws connecting the stand.

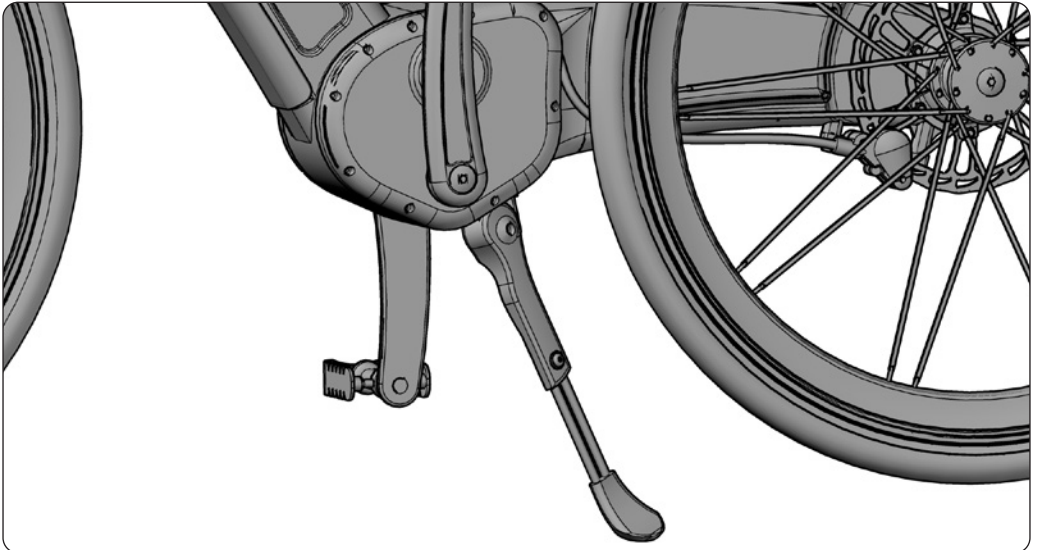

- Before setting off, always raise the stand. The stand will not lower by itself.
- Apply gentle force with your hands, making sure that the extractable part does not shift.
- Make sure the stand is firmly secured to the frame and does not move when you move it with your hands

**CHECK FOR ANY DAMAGE ON ALL THE COMPONENTS.
DO NOT MOUNT THE E-BIKE WITH THE STAND DOWN**

GENERAL USE

With your Ital E-Bike it is possible to reach unusually high speeds.

- Only use your Ital E-Bike if you are able to safely control it while riding and braking at high speeds.
- Wear a helmet when riding a bicycle.
- Ride cautiously and prudently.
- Ride in such a way that you are always ready to brake.
- Do not ride under the influence of alcohol.
- Ride in such a way that you are always in full control of your Ital E-Bike.
- In the wet conditions the effectiveness of the brakes may be reduced and braking distance will increase.
- When riding you should only wear suitable clothing that does not restrict riding and does not obstruct your view.
- In the dark, and in conditions of poor visibility, wear clothing with reflective stripes and switch on the lights if equipped .
- Attention: some layers of clothing and/or the use of a backpack could restrict movement.
- Put your foot on the pedal only when you are actually setting off.
- Release the brakes only when you are actually setting off.
- Ride with caution, respect the recommended maintenance intervals and immediately seek your Authorized Ital E-Bike Service Centre if defects are detected.

General summary of The United States Code of Federal Regulations

The CFR 16 part 1512 defines a bicycle as:

- (1) A two wheeled vehicle having a rear drive wheel that is solely human powered
- (2) A two or three wheeled vehicle with fully operable pedals and an electric motor of less than 750 watts (1) hp, whose maximum speed on a paved level surface, when powered solely by such a motor while ridden by an operator who weighs 170 pounds, is less than 20 mph.

Disabling or adjusting the speed limiter of your Ital E-Bike could violate State and Federal laws that govern public roads, highways and other public lands.

Ital E-Bike speed limit

Your Ital E-Bike has a device fitted to limit the maximum assisted traveling speed. It ensures that the maximum assisted speed (eco-standard-high-race) is kept below 20 mph as per the United States code of federal regulations. The user can exceed this limit but there will be NO electric assistance from your Ital E-Bike.

The Ital E-Bike is considered a class 1 ebike

- **Class 1:** Ebikes that are pedal assist only, with no throttle, and have a maximum assisted speed of 20 mph.

Most states treat class 1 E-bikes like a traditional mountain or pavement bicycle, legally allowed to ride where bicycles are permitted, including bike lanes, roads, multiuse trails and bike only paths. It is the riders responsibility to make sure they are compliant with all state and local codes when riding their ItalE-Bike.

ADJUSTMENTS

IDEAL HEIGHT OF THE SADDLE

The ideal height of the saddle is when, with your foot resting on the pedal in the lowest position and the knee is slightly bent, almost fully extended.

It is important that a minimum of one inch of clearance be maintained between the top tube of the bicycle and the rider's crotch, when the rider's feet are flat footed on the ground

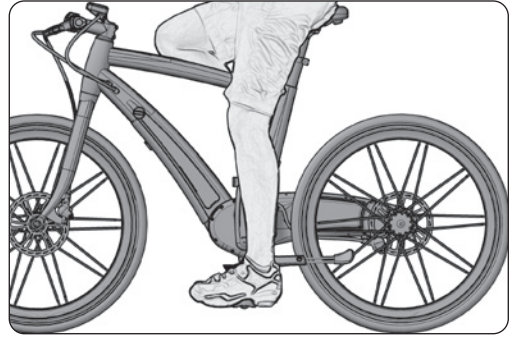

ADJUSTING THE HORIZONTAL POSITION OF THE SADDLE - FIG. 01

The saddle is secured with two screws (A) which allow forward/backward (A1) adjustments to be made and the inclination (A2) to be adjusted. You will need a 5mm Allen socket and torque wrench to perform this adjustment.

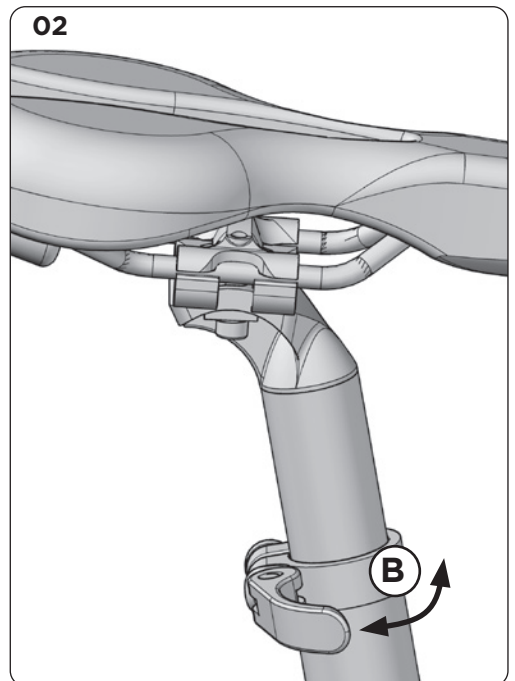
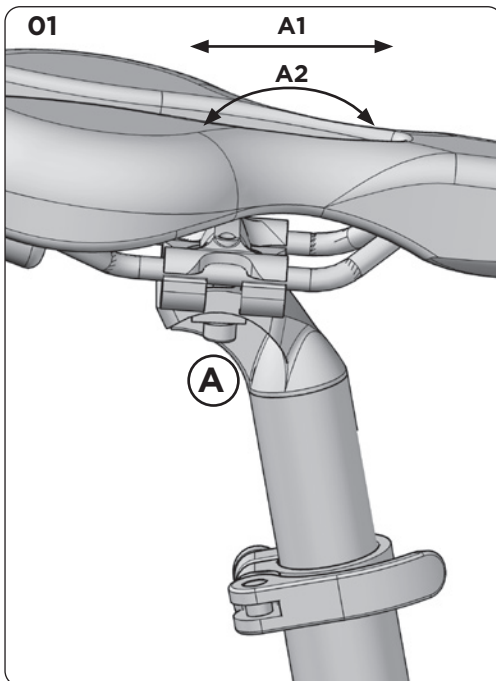

- Loosen the locking screws (**A**) by a few turns until the seat moves easily and you can adjust the inclination.
- Move the saddle to the desired position.
- Re-tighten the locking screws (**A**) with a torque wrench. The specified torque is indicated on the seatpost.

ADJUSTING THE SADDLE HEIGHT - FIG. 02 (PREVIOUS PAGE)

- Loosen the lock clamp of the seat post (**B**).
- Move the saddle with the seat post to the desired position being careful not to exceed the maximum height line marked on the post.
- Re-lock the seat post (**B**).

ADJUSTING THE SUSPENSION FORKS (IF equipped)

See the operating instructions inside the Ital E-Bike packaging.

HANDLEBAR ADJUSTMENT

Handlebar - Fig 01

1. Loosen the screws in area (A) until the handlebar is able to rotate
2. Rotate and/or position the handlebars to the desired position B.
3. Check that the handlebars are centered
4. Tighten the 4 screws to the specified torque as marked on the handlebar stem

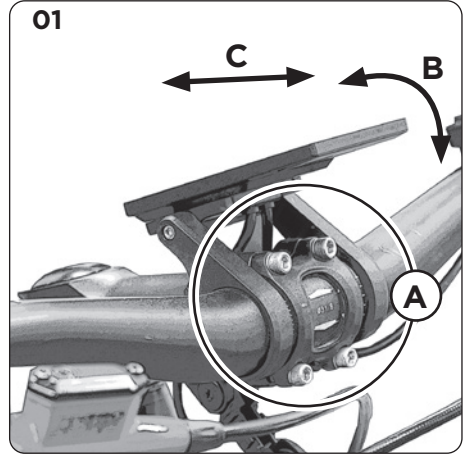

Handlebar Stem - Fig 02

1. Loosen the screws in area (A) until the support rotates.
2. Perfectly align the wheel moving in direction B while clamping the wheel as shown in Fig. 3.
3. Tighten the 2 screws in area (A) to the specified torque as marked on the handlebar stem

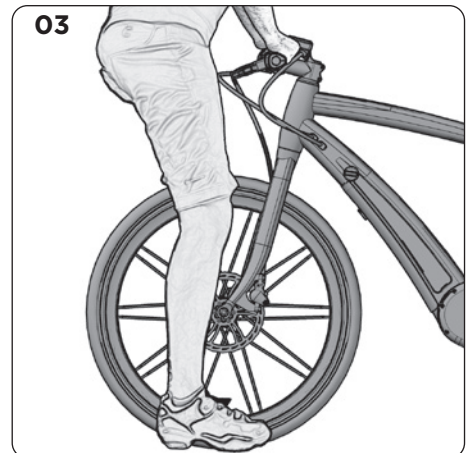
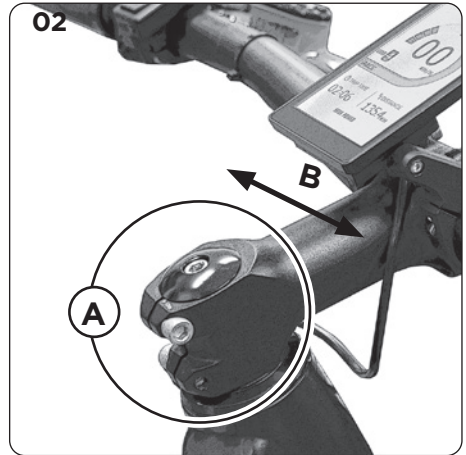

Adjustable handlebar stem (if available) - Fig 01

On some models it is also possible to vertically adjust the handlebar stem.

1. Loosen the screw (A) (Fig. 1) locking the vertical movement of the handlebar stem.
2. Adjust the stem to the desired position by moving it vertically in the appropriate direction (B) (Fig. 1).
3. Lock the screw (A) (Fig.1) to the specified torque as marked on the handlebar stem

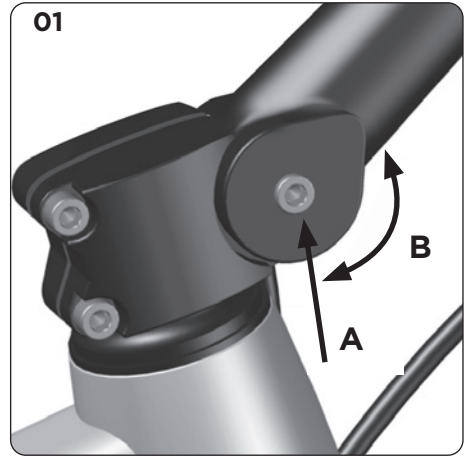

ADJUSTING THE BRAKE LEVERS.

1. Loosen the screws (1) until the brake lever begins to rotate.
2. Move the brake lever into the desired position.
3. Fasten the 2 screws with a suitable wrench to the minimum level that prevents the brake lever from rotating.

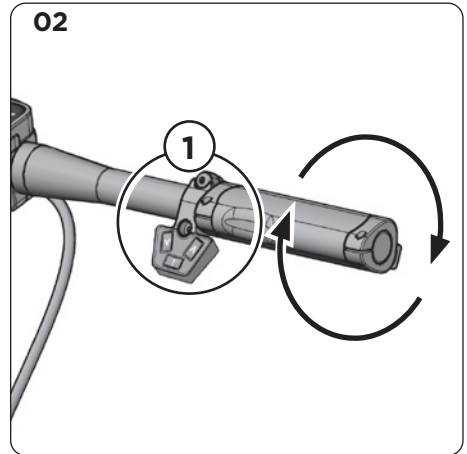

CONTROLS ON THE RIGHT SIDE OF THE HANDLEBAR

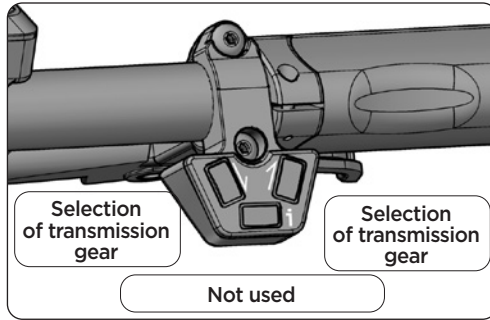

USING THE DISPLAY

FUNCTIONAL OVERVIEW

- Four buttons, easy to operate
- Use password to turn on
- Mileage display: Subtotal mileage (TRIP), total mileage (ODO)
- Speed display: Current speed (SPEED) maximum speed (MAX) average speed (AVG)
- Five Modes of power assist OFF-ECO-LOW-HIGH-RACE
- Eight levels of battery charge show the percentage of the battery power, low voltage warning
- Km / miles
- Riding time TRIP TIME display
- Adjustable display backlighting
- 3.5 mph walk assist function
- Remaining mileage display (requires BMS support)
- Real time power consumption display
- Real time display (time is on when display shutdown)
- System maintenance instructions: Advice maintenance information based on riding distance and charge cycles
- UART communication port Micro USB convenient for system maintenance, parameter setting.
- Error code indicator

Start screen



The start screen will display for 2 seconds when system is turned on

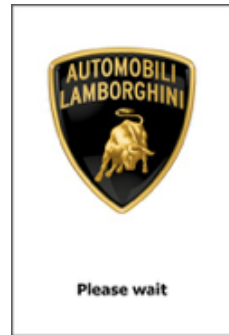

The wait screen will display for 8 seconds

Home screen

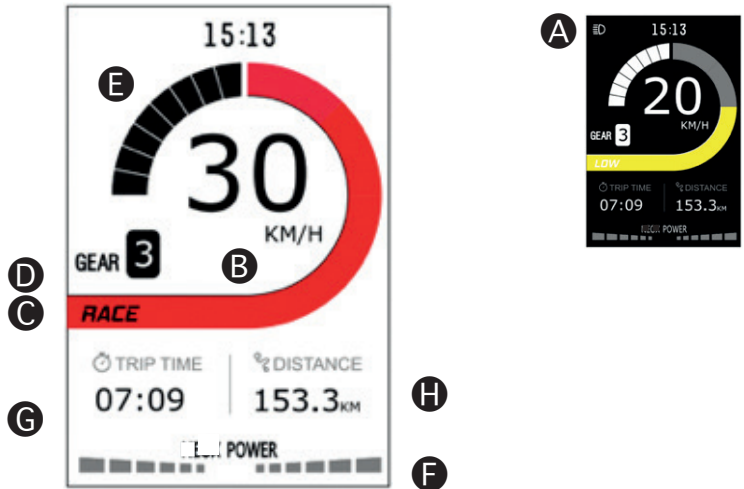

- Ⓐ Headlight: Shows only when the headlight is on.
- Ⓑ Speed: Shows current speed, KM/H or MPH
- Ⓒ Assist mode: Shows the level of assistance. OFF, ECO, LOW, HIGH, RACE.
- Ⓓ Gear position: Shows the current gear, 1-8 from low to high,
- Ⓔ Battery indicator: Shows percentage of the battery charge remaining, 1-8.
- Ⓕ Power: Shows current power demand in 6 levels
- Ⓖ Riding time: Shows the hours and minutes of the current trip.
- Ⓗ Mileage: Shows mileage of current trip.

Settings Screen

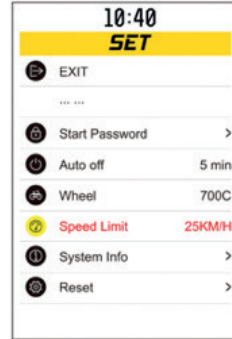
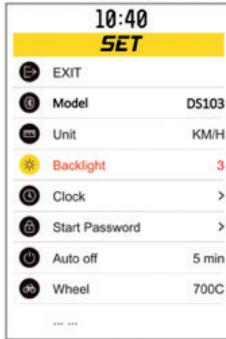

DEFINITION OF BUTTONS



- ⏻ Turn on/off
- Ⓜ Function button
 - ▲ Adjust +
 - ▼ Adjust -

OPERATION

TURN ON/OFF

Hold the on/off button for 2 seconds, the start screen will display and then the wait screen will display. Holding the on/off button again for 2 seconds will turn the display off. The display will automatically shut down if the bike is stationary for 5 minutes.

Entering the PIN

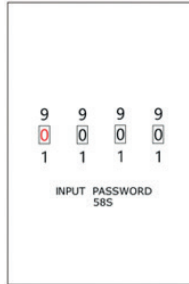

After the "wait screen" is displayed, the password screen is displayed, the correct PIN must be entered within 60 seconds to prevent the display from putting down. Press **M** to select PIN digit from left to right. Press **▲** / **▼** to select the PIN number of each digit. Press **M** after the PIN is entered. **The default PIN is (1234) The password function can be disabled and the PIN changed in the "settings menu"**

Selecting Assist Modes

Press **▲** or **▼** to select the assist mode. The assist mode can be changed at any time regardless if the bike is stationary or moving.

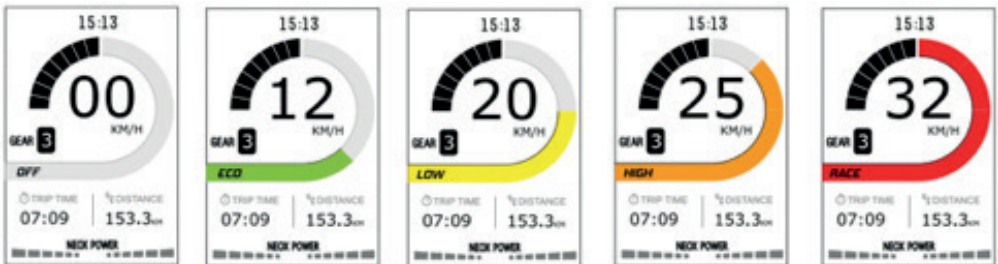

OFF / grey

ECO / green

LOW / yellow

HIGH / orange

RACE / red

Information Screens

Press **M** to select the three different information screens: TRIP TIME/DISTANCE or ODO/RANGE or AVG SPEED/ MAX SPEED.

The three information screens are shown below



*TRIP TIME
DISTANCE*

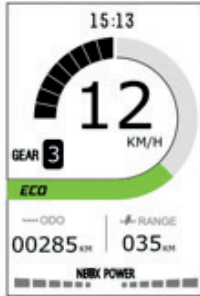

*ODO
RANGE*

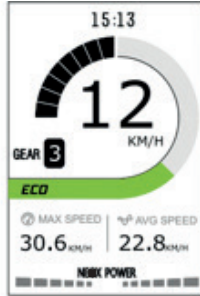

*MAX SPEED
AVG SPEED*

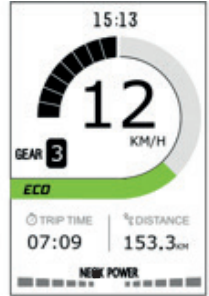

*TRIP TIME
DISTANCE*

WALK ASSIST MODE

1st gear must be selected to operate walk mode.

Hold the **▼** button for 2 seconds, after selecting 1st gear . The **WALK** icon will appear. Press the **▼** button to exit walk assist mode

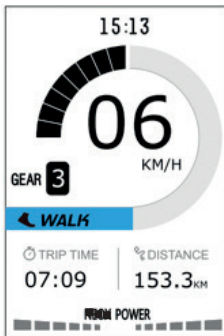

Walk assist mode

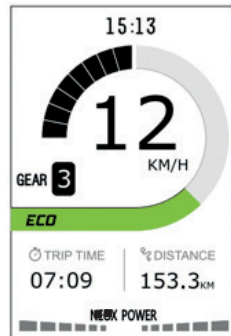

Normal mode

HEADLIGHT ON/OFF(DAY AND NIGHT MODE SWITCH)

Hold the ▲ button for 2 seconds to turn on the headlight. The display will change to night mode and the headlight icon will appear. Hold the ▲ button again for 2 seconds to turn off the headlight and return the display to daytime mode.

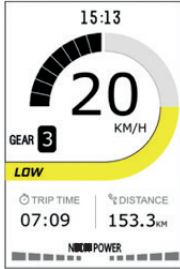

Battery level

Battery level is shown on the home screen. The display will show 0 and begin to flash when the battery has less than 5% charge remaining.

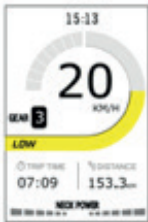

Level 0

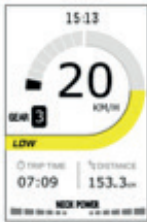

Level 1

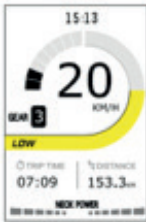

Level 2

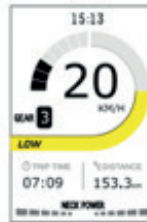

Level 3

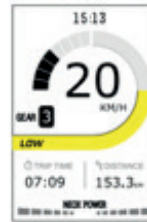

Level 4

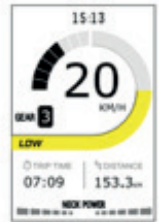

Level 5

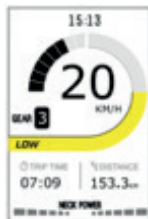

Level 6

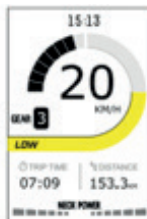

Level 7

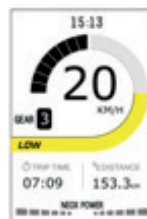

Level 8

Current power demand

Instantaneous power demand is shown as a horizontal bar graph at the bottom of the home screen.

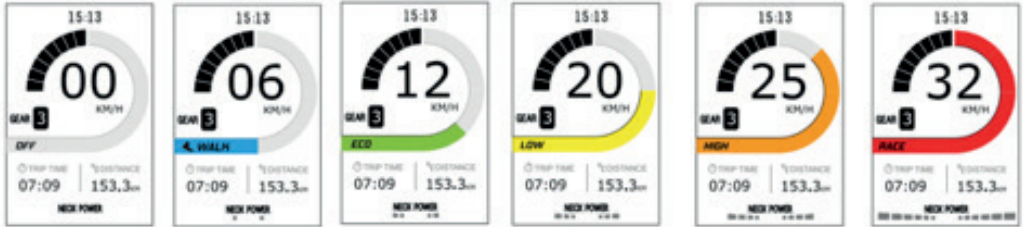

Level 0

Level 1

Level 2

Level 3

Level 4

Level 5

USER SETTINGS

Through the settings screen the user can adjust the backlighting, clock, automatic shut down delay, and password settings. Wheel diameter and speed limiter data is also available to Itel E-Bike service personnel on this screen.

ENTER SETTING SCREEN

- Within 10 seconds of turning on the display, and the bike being stationary, hold the **[M]** button for 2 seconds. The settings screen will display and users can set and view the parameters of the display.
- Press **▲** / **▼** to scroll between items on the settings screen. Press **[M]** to select an item. If no items are selected within 10 seconds the display will return to the home screen without saving any changes.
- To exit the setting screen and return to the home screen, select **[Exit]** and hold **[M]** for 2 seconds. This will save any changes.

EXITSETTING SCREEN

- To exit the setting screen and return to the home screen, select **[Exit]** and hold **[M]** for 2 seconds. This will save any changes.

UNIT SETTING

Unit: Metric/Imperial

- Enter unit setting screen, press ▲ / ▼ to choose KM/H or MPH. Press **M** to save the parameter and exit unit setting screen and return to setting screen.

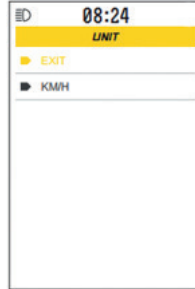

BACK LIGHT SETTING

Brightness adjust screen

- Press ▲ / ▼ to choose the level of the backlight, Level 5 is the brightest. Press **M** to select and return to settings screen



CLOCK SETTING

- Select the clock setting screen. Press ▲ / ▼ to select the hour, press **M** to select the minutes. Press **M** again to exit and return to the settings screen

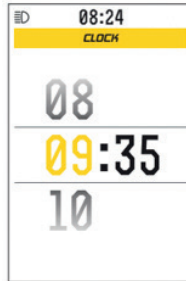

PASSWORD SETTING SCREEN

Exit: exit start password screen

Start Password: Password function ON/OFF

Setting Password: Changing the password

- Press ▲ / ▼ to scroll between, "Exit", "Start Password", and "Setting Password",
- Select "Start Password" press [M] to select password ON or OFF
- Select "Setting Password" press [M] select the digit of the password press ▲ / ▼ to modify the password number of selected digit, Press [M] to verify the original password after 4 digit password selected

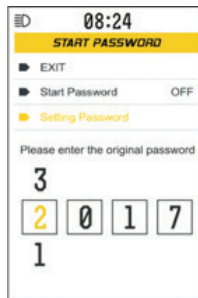

When the original password is entered correctly, the new password screen will appear

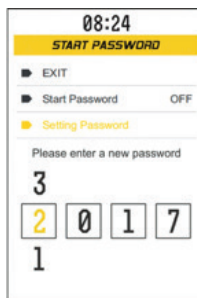

The new password will need to be entered twice

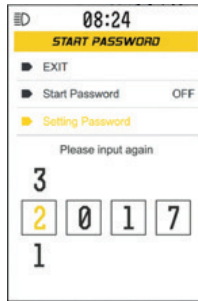

After entering the new password press **M** and exit the screen

AUTOMATIC SHUTDOWN TIME SETTING

- 10 minutes: Automatic shutdown if 10 minutes no operation and speed of the bike
- 20 minutes: Automatic shutdown if 20 minutes no operation and speed of the bike
- 30 minutes: Automatic shutdown if 30 minutes no operation and speed of the bike
- 40 minutes: Automatic shutdown if 40 minutes no operation and speed of the bike
- 50 minutes: Automatic shutdown if 50 minutes no operation and speed of the bike
- 60 minutes: Automatic shutdown if 60 minutes no operation and speed of the bike

Press **▲** / **▼** to choose : 10 minutes, 20minutes, 30 minutes, 40 minutes, 50 minutes, 60 minutes. press **M** to select and save the settings and return to SETTINGS screen.

With Automatic shutdown enabled, the bike can only be turned on again by pressing the **⏻** button.

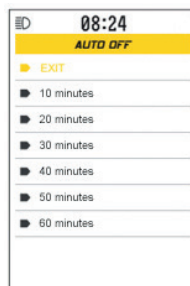

WHEEL DIAMETER AND SPEED LIMITATION INFORMATION

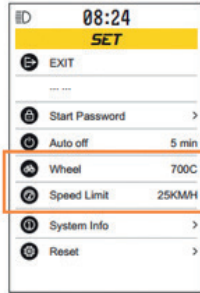

Wheel diameter and speed limitation information can only be set by an authorized Ital E-Bike dealer. Users can only view these settings.

SYSTEM INFORMATION REVIEW

S/N: Serial number of equipment

FW version: Firmware version number

HW version: Hardware version number

*Motor INFO: (Need support from controller)

*BMSINFO: (Need support from controller)

*Controller INFO (Need support from controller)

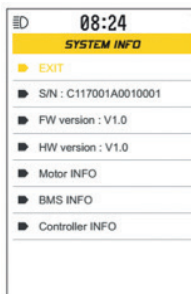

e.

RESET

Exit: Exit RESET interface

Yes: Reset to factory settings

Short press ▲ / ▼ to select Exit, Yes, select Yes then short press **M** to return to factory settings (unit, backlight brightness, turn on password, auto shut off time) and return to user setting interface. Choose Exit and short press **M** to return to SET interface.

Interface shown as below:

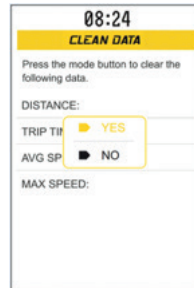
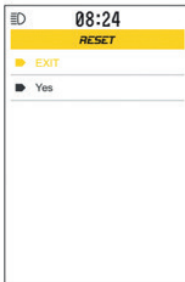

DATA CLEARANCE

10 seconds within display turned on, and speed is 0, long press **M** (2 seconds) enter the data clearance interface, short press **M** to clearance trip mileage (TRIP), riding time (TRIP TIME), average speed (AVG) and maximum speed (MAX). Then display pop up the confirmation window, short press **M** again to clearance all listed items. Display will return to riding interface without data clearance if no operation in 10 seconds. Shown the data clearance interface as below:

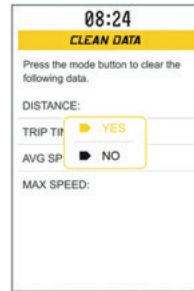
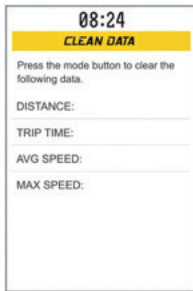

IMPORTANT NOTE

- Do not unplug the display when it is turned on
- Avoid exposure to harsh environments like heavy rain, heavy snow, and strong sunlight.
- Contact your Ital E-Bike dealer if the display has any problems.
- **Damage caused by excessive twisting is not covered by the warranty**

ERROR INFORMATION

Nr.	Status data	Description	Note
1	0x01	Normal status	LED of controller is on
2	0x03	Already brake	Display will not show
3	0x04		Torque sensor
4	0x05	Throttle error	
5	0x06	Under voltage protection	Display will not show
6	0x07	Over voltage protection	
7	0x08	Hall signal error of motor	
8	0x09	Phase wire error of motor	
9	0x10	Temperature of motor reaches the protect temperature	
10	0x11	Temperature sensor of motor error	
11	0x12	Current sensor error	
12	0x13	Temperature error inside battery	
13	0x14	Temperature of controller reaches the protect temperature	
14	0x15	Temperature sensor of controller error	
15	0x21	Speed sensor error	
16	0x22	BMS communication error	Display can't get the information, will not show the code
17	0x23	Front light error	
18	0x24	Light sensor error	
19	0x25	Torque signal error from torque sensor	
20	0x26	Speed error from torque sensor	
21	0x30	Communication error	Display will check communication error automatically, controller will not send this message

HOW TO ACTIVATE THE ITAL E-BIKE ANTI-THEFT SYSTEM

The bike has two anti-theft systems.

- The first inhibits transmission and can only be deactivated by entering the Ital E-Bike Pin code. See page 29 "turning on/off"
- The second system consists of the mechanical locking of the rear wheel.

LOCKING THE REAR WHEEL

1. With the bike stopped put the key into the lock.
2. Turn the key 360° counter-clockwise. It may be necessary to slightly move the wheel back and forth to complete a full turn of the key.
3. Remove the key.

Always be sure to unlock the wheel before using the bike !!!

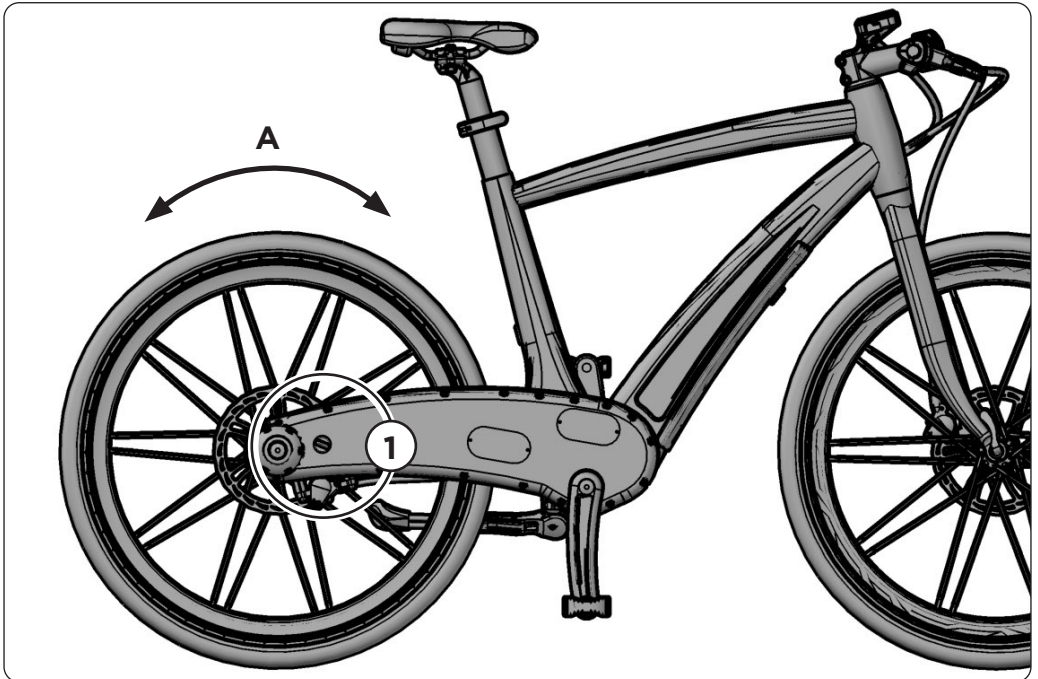

THE BATTERY

USEFUL INFORMATION ABOUT THE BATTERY

The charging process must be carried out in a well ventilated area. The battery can be installed in the bicycle or removed from the bicycle while charging.

Before charging make sure the battery has not been subjected to large fluctuations in temperature, if so wait 30 minutes for battery temperature to stabilize

While charging a red light is lit on the battery charger.

When the green light turns on, this means charging is complete (100% charge in about 5 hours, 80% charge in about 4 hours)

- **It is not recommended to leave the battery discharged as this may seriously damage it.**
- **When the battery is discharged do not try to use up the little power remaining but proceed to recharge it otherwise the battery will be damaged severely.**
- Do not leave the battery to charge for more than 12 hours.
- Never charge the battery in extremely hot conditions.
- Never charge near flammable liquids.
- Do not cover the battery and/or charger in any way.
- While charging the battery heats up slightly.
- Only use the supplied power adapter.

If the battery is not used for a long period of time, it is advisable to recharge the battery every 3 months and to keep it in a dry area at a temperature between 32°F and 85°F to avoid damaging it.

Ambient temperature during charging: between 32°F and 90°F.

Ambient temperature during normal operation: between 20°F and 100°F.

The battery does not require maintenance. In the event of failure or a significant reduction in performance or range contact your Authorized Ital E-Bike Service Centre. If the battery emits a bad smell, unplug it from the charger and contact an Authorized Ital E-Bike Service Centre.

The battery undergoes a capacity reduction of 20% after 600-800 cycles.

The exhausted battery (end of life) should not be thrown away with normal waste. NOTE: The battery performance will vary according to the weight of the rider, the presence or absence of uphill climbs, the conditions of the road surface and the temperature.

In summer, range is significantly higher than in winter.

Warnings

- **The first time the battery must be recharged for at least 7 hours.**
- **For the first 5 uses completely charge the battery and then fully discharge it. This will ensure the maximum performance of the battery pack.**
- **Do not store the Ital E-Bike for long periods with the battery discharged.**

THE Ital E-Bike BATTERY

The Ital E-Bike battery (Fig 1) is a battery pack constructed with Samsung cylindrical cells. The lithium-ion batteries have a high energy density and are perfect for cyclic applications. Compared to traditional lead-acid batteries, lithium-ion batteries have advantages in terms of savings: up to 70% reduction in volume and weight, while the number of charging cycles is three times higher.

Another important advantage of the Ital E-Bike lithium-ion battery is that it is equipped with a Battery Management System (BMS) that automatically compensates for any imbalance between the cells, to ensure maximum safety and durability of the battery. The Ital E-Bike lithium-ion battery is equipped with a battery cell integrated safety control system.

Unlike other batteries, lithium-ion batteries have no memory effect and can be charged even if they are fully discharged.

The total battery capacity is reached after 4.5 complete cycles of charging - discharging. **The first time the battery must be recharged for at least 7 hours.**

BATTERY TECHNICAL DATA

Battery:	lithium ion, removable
Nominal power:	48 V
Rated capacity:	10.5 Ah
Weight:	5.5 lbs
Dimensions:	360x90x85 mm
Charging time:	4-5 hours (first time minimum 7 hours)

Only recharge the battery using the supplied battery charger.

Press the “charge status” button (1), present on the upper side of the battery, to see the charge level of the battery.

- 3 lights on, fully charged battery**
- 2 lights on, battery charged**
- 1 light on, low battery**
- 0 lights on, low battery or faulty fuses**

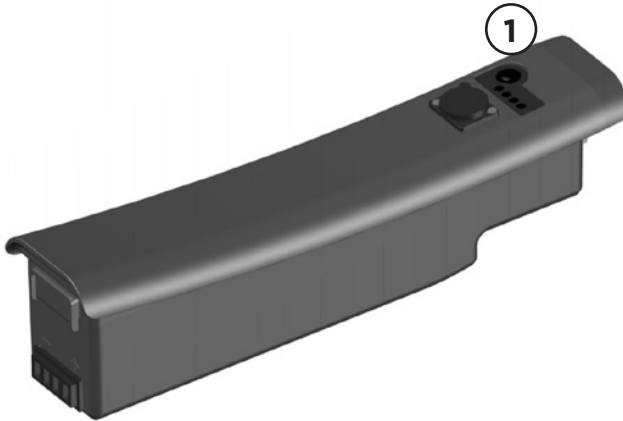

REMOVING AND INSTALLING THE BATTERY

The Ital E-Bike battery has been designed to be inserted into the main tube of the frame. This “disguises it” and makes it invisible to the eye, hence improving the design of your Ital E-Bike, but above all to provide it with increased protection, inside a hydroformed aluminium shell to prevent damage.

Lock for instalation and removal of battery

Features:

The key can only be removed in the CLOSED position.

1 CLOSE position: the battery is inserted and locked in the correct position.

2 OPEN position: the battery is unlocked and can be removed from the bike.

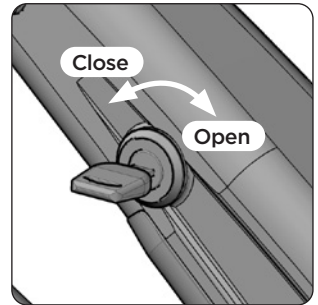

REMOVING THE BATTERY

Support the battery (2) with one hand. Turn the key clockwise (fig. 1) until completely rotated to the right. Pull out the battery by tilting it downwards. (fig.3)

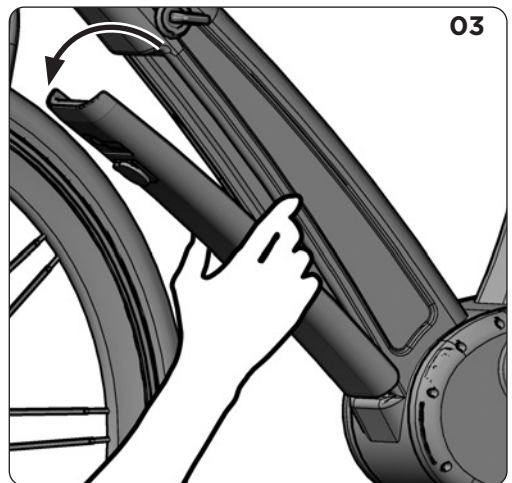
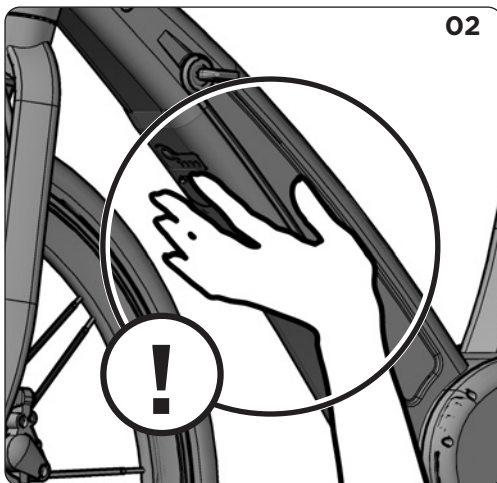
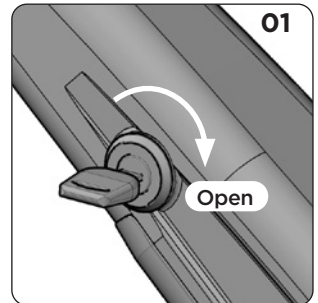

INSTALLING THE BATTERY

To install the battery be sure that the key is turned to the CLOSED position.

Take the battery with your one hand as shown. (Fig.1) and insert the bottom of the battery into the housing inside the main frame tube at a downward angle (Fig. 2), making sure that the coupling on the bottom of the battery box (Part A) fits properly on the lower edge of the frame tube (Part B) as shown in (Fig.3) Push the battery firmly upward until the "click" can be felt. The battery is now locked inside the frame and ready for use.

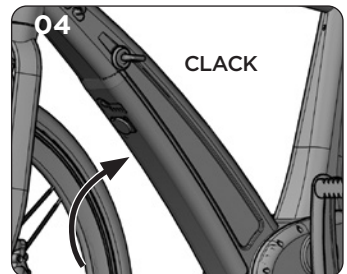
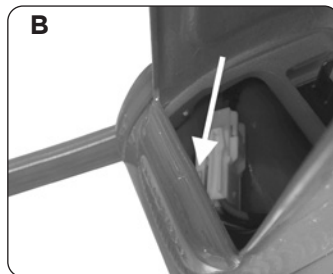
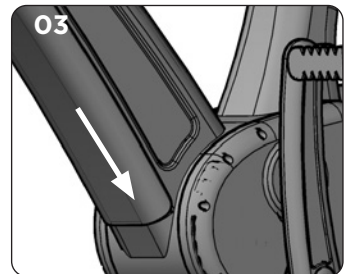
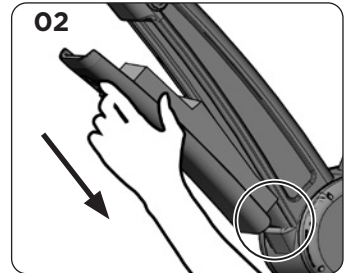
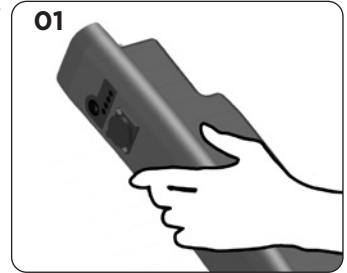
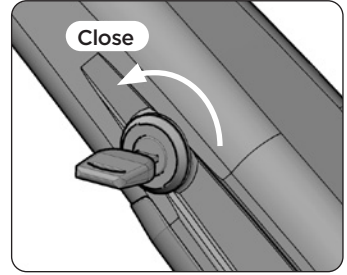

HOW DOES THE Ital E-Bike BATTERY PERFORM DURING USE

It's important to remember that the Ital E-Bike battery reaches its best performance after the first 4 or 5 full charging and recharging cycles and when it is recharged for the first time for at least 7 hours.

The intelligent electronic management system of the Ital E-Bike battery (BMS) protects the lithium-ion battery. The BMS controls each single cell, after the first few recharges it balances the cells and thereby prolongs the battery life.

While using your Ital E-Bike it's important to understand what happens with the gradual discharge of the battery. In fact the Ital E-Bike is a fully electronic e-bike, including gear changes. The system has been designed so that the user is able to use the Ital E-Bike as a normal bike even with the battery completely discharged. Even with a low battery, there will be a reserve of energy That will allow the rider to use the electronic gear change system and reach their destination.

During use, with a fully charged battery, the Ital E-Bike will have more assistance power available, in all four assistance modes. As the energy in the battery decreases, the power available to your Ital E-Bike will gradually decrease. If we are using the bike for example in HIGH, at a certain point, The bike will change to STANDARD mode, then change again to ECO mode until all of the available energy in the battery has been used before changing to NO ASSIST mode.

BATTERY LIFE

The life of a Battery depends mainly on the type of use. Like any lithium-ion battery, the Ital E-Bike battery ages naturally, even when not in use.

Factors that shorten the life span:

- Excessive use
- Storage at an ambient temperature greater than 90 °F
- Long periods of storage with the battery fully discharged
- Exposing the battery to excessive heat

Factors that have a positive effect on the battery life:

- Moderate use
- Storage at an ambient temperature of (32 – 75 °F)
- Storage with the battery charged to about 60 %

The figure shows a typical evolution of the energy content according to the duration and frequency of use.

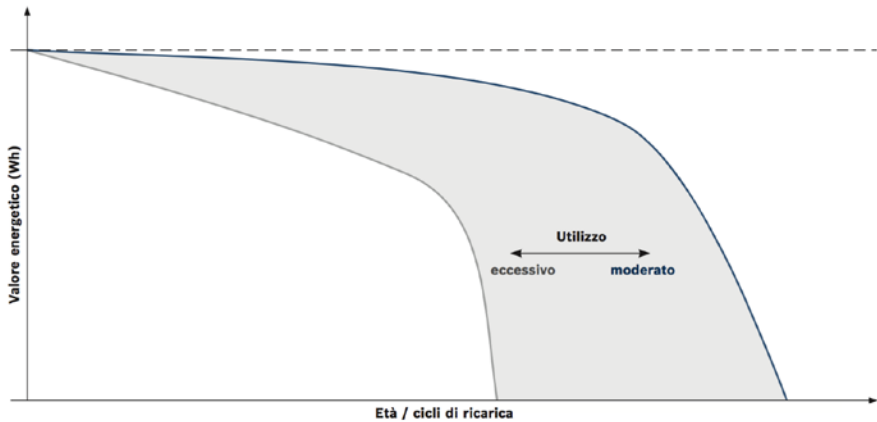

CHARGING THE BATTERY

The Ital E-Bike battery can be charged either while installed on the bike (Fig. 1) or when removed from its housing (Fig. 2) by inserting the charging connector plug into the front of the battery.

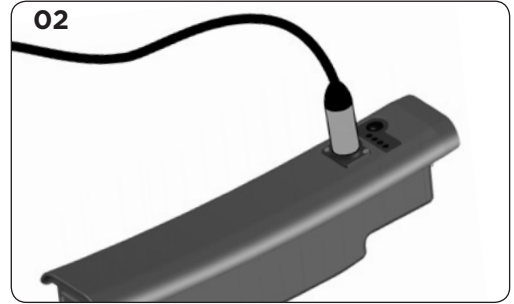
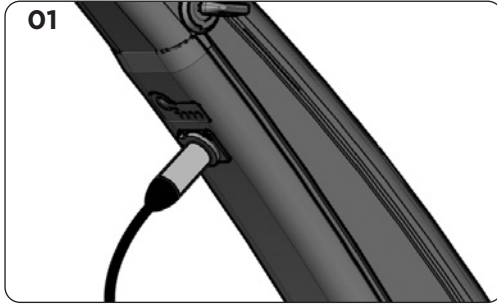

The charging process must be carried out in a ventilated room or garage.

INSTRUCTIONS FOR RECHARGING

Follow the instructions carefully to reduce the risk of fire or electric shock.

1. The lithium ion battery charger should only be used with the original rechargeable battery. Other types of batteries may cause damage to people and property.
2. The battery charger is intended for use indoors and in dry places.
3. The main outlet must be near the equipment and be easily accessible.
4. The charger must not be repaired and, if faulty or damaged, should no longer be used.
5. If the charger is damaged or no longer charges, return it to the shop where it was purchased. Do not dispose of it together with household waste.
6. The charger is intended for use in a horizontal position or on the floor.
7. The power charger can function at different input voltages without the need for adjustment by the user.

CAUTION

Carefully observe the following instructions when charging.

1. Keep the battery recharging equipment out of the reach of children and avoid entangling the wires.
2. To avoid the risk of electric shock, do not insert the plug with wet hands or when the electrical parts are wet, and prevent the charging equipment from coming into contact with water or other liquids.

3. Do not clean your bike with water during the battery charging procedure.
4. For longer battery life, use only original Ital E-Bike equipment for the charging
5. Do not pedal or ride the bike while charging the battery, so as to avoid falls or seriously damaging the charging equipment.
6. Do not place clothing on the equipment during charging.
7. Be careful not to crush the cable during charging to prevent short circuits.
8. Use only individual power sockets.
9. Do not pull the cord to remove the plug from the socket.

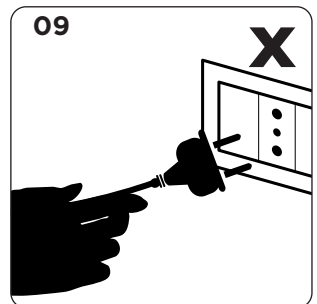
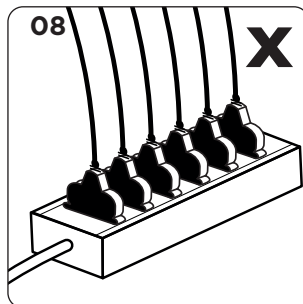
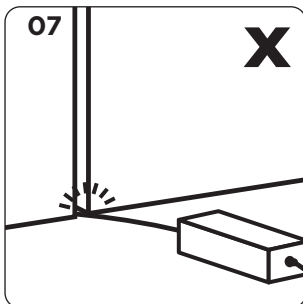
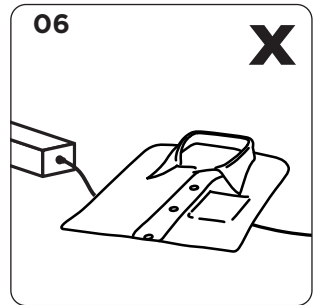
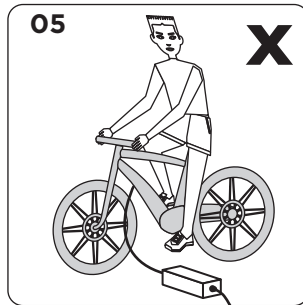
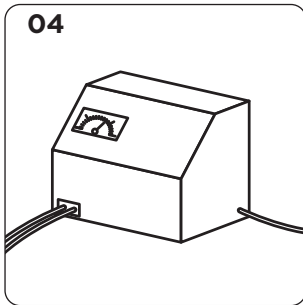
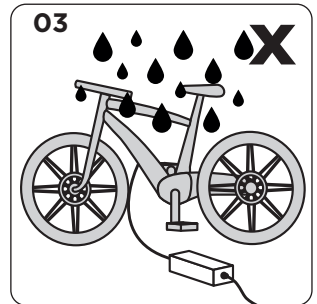
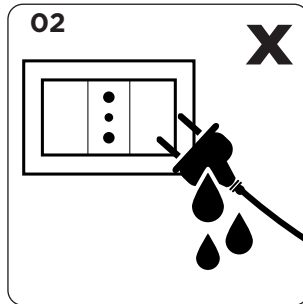
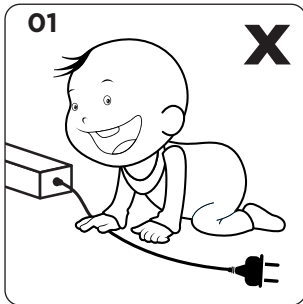

HOW TO USE THE BATTERY CHARGER

1. Be sure that connections are in good condition and not damaged in any way.
2. Insert the plug (1) of the power set in a 110 AC outlet. If the plug is inserted in the AC outlet without the battery connected, the two LEDs will be red and green, indicating stand by mode.
3. Connect the connector (2) to the battery.
4. Both LEDs becomes green when the battery is completely charged. When the battery is completely charged, remove plugs 1 and 2

These instructions are also contained inside the battery charger packaging.

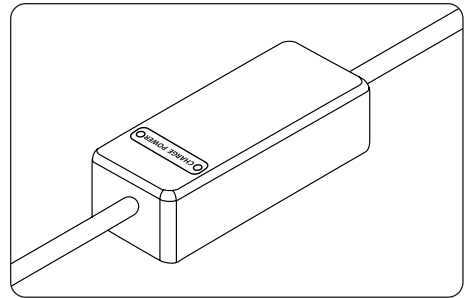
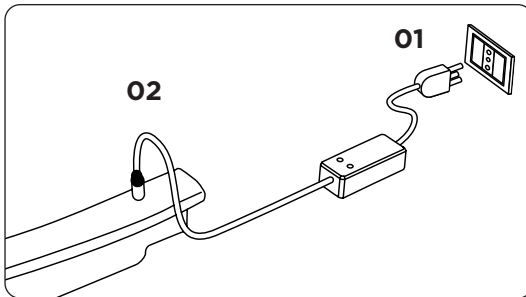

WARNINGS

- The first time the battery must be recharged for at least 7 hours.
- For the first 5 uses completely charge the battery and then fully discharge it. This will ensure the maximum performance of the battery pack.
- Fully charge the battery before long term storage.
- Do not store the e-bike for long periods with the battery uncharged.

CHARACTERISTICS OF THE BATTERY CHARGER

Input voltage:	100-240V AC
Frequency:	57-63Hz
Absorbed current:	1.5A
Output voltage:	48V DC
Maximum current output:	2A

- While charging a red light is lit on the battery charger. When this light turns green, charging is completed.
- During charging place the battery charger in a horizontal position and in a ventilated environment which is not exposed to direct sunlight.
- Never charge in the vicinity of liquids, whether they are flammable or not.
- Do not place the battery charger and the cord in water or in places with high humidity.
- If the charger is subjected to large fluctuations in temperature, wait 30 minutes prior to use.

GEARBOX 8 SPEED

Your Ital E-Bike is equipped with an innovative gearbox that is similar to that found on a motorcycle or car. It uses a rotary gear selector that is controlled electronically by microswitches on the handlebars.

The bike has 8 sequential speeds available. Nothing could be more simple for the user. Gear changes can be made while stationary or moving

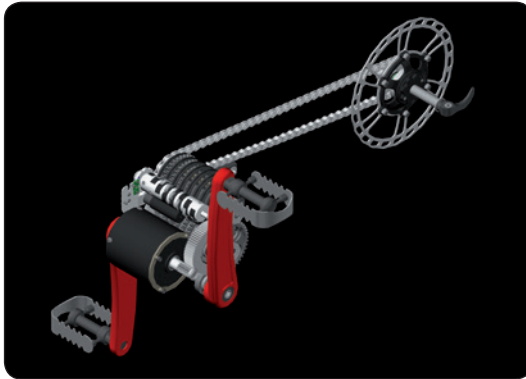

Like all innovations, this system needs to be understood so that you can quickly take advantage of all the benefits that the system presents.

Below are some tips and advice.

INTRODUCTION

Gear 1 (lowest gear)

The pedaling resistance decreases and the speed achieved is lower, but it is easier to climb hills.

Gear 8 (highest gear)

The resistance to pedaling increases and the speed achieved is higher.

First we shall describe difference between UPSHIFTING and DOWNSHIFTING.

The gear change is performed by pressing the electric buttons on the right side of the handlebars. (Fig.1)

The right button increases the gear, the left button decreases the gear.

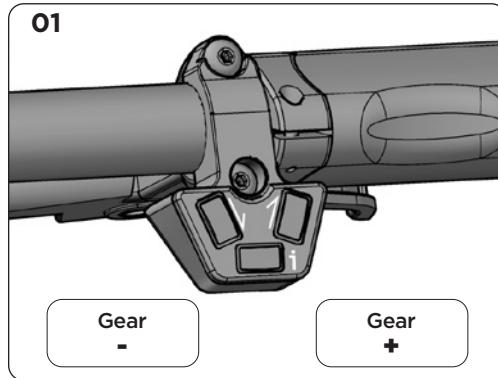

UPSHIFT (OR INCREASE IN GEAR)

This is the change from one gear to a higher gear, i.e. from gear 1 to 8.

This may be carried out at any time whether the bike is moving or stationary, and regardless of the force on the pedals.

The gear change is sequential and has been designed so that it does not require any special skill by the user.

The system first engages the desired gear, once this is engaged, the system disengages the previous gear. This allows an almost seamless gear change

DOWNSHIFT (OR DECREASE IN GEAR)

This is the change from one gear to a lower gear, i.e. from gear 8, to gear 1.

As it is an extremely rapid change, the climb must be performed while bearing in mind some features of the system:

The bike incorporates a SAFETY system that inhibits downward gear changes by the user while pushing on the pedal. In the event the wrong button is pressed or repeated pressing of the button, this system avoids a sudden increase in pedaling frequency that could unbalance the user, resulting in danger to themselves or others. Therefore, to perform the downshift (increase in gear) it is necessary to slightly decrease the effort on the pedals.

MOTOR

The Ital E-Bike has an electric assistance motor integrated with the gearbox and contained in a die-cast aluminum housing. The brushless 48volt 500watt motor requires no maintenance

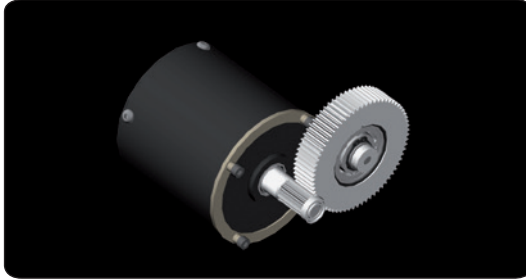

The motor capable of an output of 500 W with an efficiency level of 85%. The motor weighings only 2 kg. and works without friction thanks to brushless technology.

Like any other part of the bicycle, the motor life depends on its use. Under standard conditions, the life of the motor can vary between 10 to 20 years or up to 100,000 km.

The motor will emit a certain level of noise during use, this is normal and depends on the effort to which it is subjected. In case of abnormal noises, heat, smoke, performance loss, etc... contact your Author-ized Ital E-Bike Service Centre.

CAUTION

Use in rainy conditions: the motor as well as the electrical connectors, are properly protected for use in rainy conditions, as they are entirely sheltered inside a die-cast aluminium .

ADJUSTING ASSISTANCE

The motor provides extra power, proportionate to the effort, as soon as you start pedaling. This power can be adjusted so as to optimize the range of the bicycle. Four levels, or "modes" of assist can be selected by buttons on the left handlebar. The modes can be selected at any time the bike is turned on regardless of whether the bike is moving or stationary.

MAINTENANCE AND CARE

Regular and proper care of the bicycle is important and one of the conditions for maintaining the warranty. Corrosion caused by poor maintenance or damage caused by winter weather conditions is not covered by the warranty. Protect your Ital E-Bike from any contact with corrosive substances by using a spray wax or a similar protective product. Clean your Ital E-Bike after any contact with corrosive substances and reapply the protection as described below. For washing do not use pressure washers. A strong pressure washer can damage your Ital E-Bike and result in a short circuit (fire hazard).

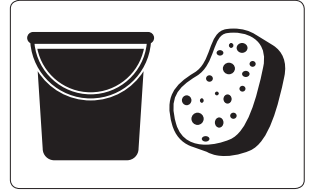
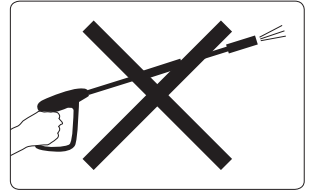

PLEASE NOTE:

Proper maintenance extends the life of the bike and its components.

1. Perform regular cleaning and maintenance of your bike.
2. For washing use only a gentle water spray or a bucket of water and a sponge.
3. Use only clean fresh or desalinated water. Do not use salt water (e.g. seawater).

With many detergents and in the presence of low levels of dirt, it is sufficient to spray the product and rinse after leaving it to act for the prescribed time. Then stubborn dirt can be removed with a brush before rinsing.

Cleaning agents, lubricants and protective agents are chemical products. Some of these products can damage your Ital E-Bike. Only use products specifically designed for bicycles. Make sure the products do not attack paint or rubber parts, plastic, metal, etc. Consult your dealer. Strictly follow the indications of the manufacturers.

PLEASE NOTE:

AFTER THE FIRST 500 KM CARRY OUT AN INSPECTION OF ALL SCREWS OF THE SINGLE ARM FORK ON THE Ital E-Bike. SUBSEQUENTLY CARRY OUT THIS IN-SPECTION EVERY 1000 KM.

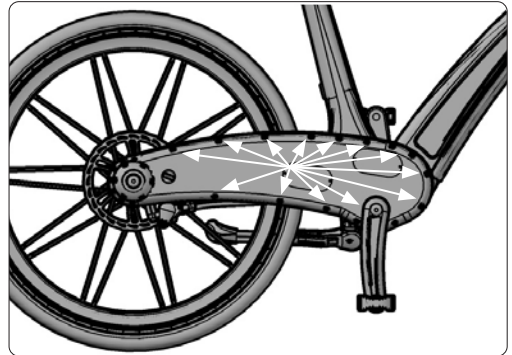
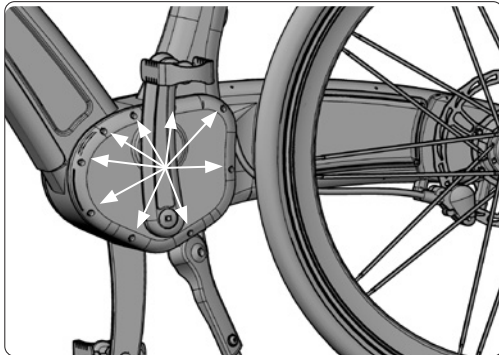

WASHING

For washing do not use steam jets or high pressure cleaners. A strong jet of water can damage your Ital E-Bike or result in a short circuit (fire hazard). For this reason it is advisable to adopt the procedures described below.

1. Turn off the Ital E-Bike using the display and remove the key from the lock.
2. Protect the display with a bag and seal it.
3. Remove the first layer of dirt with a gentle stream of water.
4. Spray on a cleaning agent.
5. Gently rub with the help of a cloth or sponge and after washing rinse with a stream of water **NOT AT HIGH PRESSURE.**
6. Remove the battery and blow inside the frame to remove any standing water.
7. Remove the rear wheel and clean the shaft and hub assembly.
8. Grease the mating surfaces with lithium grease, which is water resistant.

VERY IMPORTANT!!!

Keep the mating surface between rear hub and wheel (A) always lubricated with lithium grease.

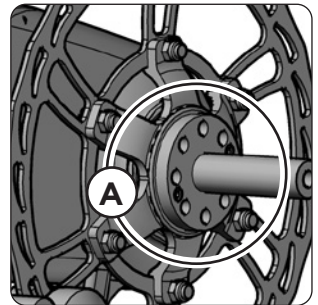
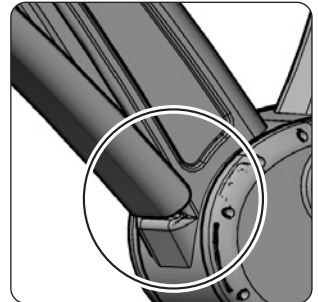

PUTTING THE BICYCLE OUT OF SERVICE

PREPARING THE BICYCLE FOR STORAGE

Keep the Ital E-Bike in an enclosed environment protected from the sun and rain. Regularly check the tire pressure, remove the battery and charge it every 2-3 months.

RECYCLING

The construction materials of the bicycle require special disposal procedures. In the case of recycling refer to local regulations for the disposal of the materials composing the bike. Under no circumstances must the product be discarded into the environment, as it represents a source of pollution in the long term. The ability to reuse some parts of the bicycle, as mechanical units or for raw materials for other purposes, is carried out under the user's own responsibility.

CAUTION:

Reuse of any unit after the decommissioning of the bicycle waives the manufacturer from any liability arising from the use of the uni

DISPOSAL OF YOUR Ital E-Bike

Your Ital E-Bike, like all electrical and electronic equipment, contains materials which are harmful to the environment and human health, and contains materials that can be re-used and recycled.

Dispose of your Ital E-Bike at a municipal refuse collection point. For detailed information on proper disposal of your Ital E-Bike, please contact your local council or your dealer.

QUESTIONS AND ANSWERS

Question: What speed can I ride this bike at?

Answer: *It depends on the cyclist. There is no maximum limit. In any case, at speeds above 20 mph, the assistance will be deactivated.*

Question: Are Ital E-Bikes bicycles very heavy?

Answer: *No. In fact, given that the weight of the Ital E-Bike bicycle is between 20 kg and 24 kg depending on the model, it is considered to be among the lightest electric bikes on the market.*

Question: Should I take any additional precautions to be able to ride an Ital E-Bike with re-spect to a traditional bicycle?

Answer: *No, although it is important to pay attention when turning on your Ital E-Bike (as described in this manual), because of the additional impulse of the motor. It is recommended to start movement in Eco mode, with lower force and a low gear.*

Question: Do I have to stop every time I want to activate the pedal assistance?

Answer: *No. The pedal assistance can be activated while riding the bike, although it is not recommended as it may constitute a distraction. No special precautions are required apart from the advice in this manual.*

Question: Can I remain stationary on the bike when waiting at traffic lights?

Answer: *Yes. The motor will remain inactive provided that no pressure is applied to the pedals. As force is exerted on the pedals you will notice the bike pushing forward. This is a consequence of the continuous reading by the torque sensor measuring the force exerted on the pedal.*

Question: Can I change gears while the bike is stationary, such as when waiting at traffic lights?

Answer: *Yes. The Ital E-Bike sequential gearbox permits this. If you arrive at the traffic lights in a high gear, while waiting, even with the bicycle stationary, you can prepare the correct gear for setting off again.*

Question: How often do I have to take the bike to a Ital E-Bike dealer for a service?

Answer: *No electrical component of the Ital E-Bike pedal assistance system require maintenance. The rest of the components require the same attention as the components of a standard bicycle, depending on the frequency of use.*

Question: What happens if I get a puncture? Can I repair the tire myself?

Answer: *Without any problem. The front wheel must be removed as with any normal standard bike, the rear wheel is further facilitated by the single arm fork system.*

Question: Do I have to charge the battery when I'm not using it?

Answer: *For proper use and maintenance of the battery, read the battery section of this manual.*

Question: What should I do when I'm not going to use the bike for a long time?

Answer: *It is recommended to charge the battery to 70-80% before storing it for an extended period. Likewise, it is recommended to check the charge level of the battery every three months.*

Question: Why is the range reduced when there is frost or very cold weather?

Answer: *Because below freezing the performance of the battery deteriorates. This factor does not pose any problem or damage the battery, it just prevents you from fully discharging the battery reducing the range of the bicycle.*

Question: Can I buy a spare battery?

Answer: *Yes, extra batteries are available from Ital E-Bike retailers. If you need greater range and do not have the possibility of recharging the battery between the two trips, it is recommended to buy a spare battery.*

Question: I can use the battery from another electric bicycle?

Answer: *Yes, provided that the battery is produced for another Ital E-Bike. Batteries from other e-bikes are not compatible.*

Question: Can I make copies of the keys to lock the battery?

Answer: *Yes, it is a flat key. Just ask your Ital E-Bike dealer for the key blank and have it copied at any hardware store.*

Question: Do I have to wear a helmet?

Answer: *The wearing of helmets for cycling, depends on the laws of each country. In any case, for safety reasons, we recommend the use of helmets.*

Question: Do I have to have insurance for third party liability?

Answer: *Insurance is not mandatory, it is only recommended.*

Question: Is there a minimum age for use of the Ital E-Bike?

Answer: *Children are not permitted to ride the Ital E-Bike*



CROSSER



sporter

