

CLASH-A-RAMA!

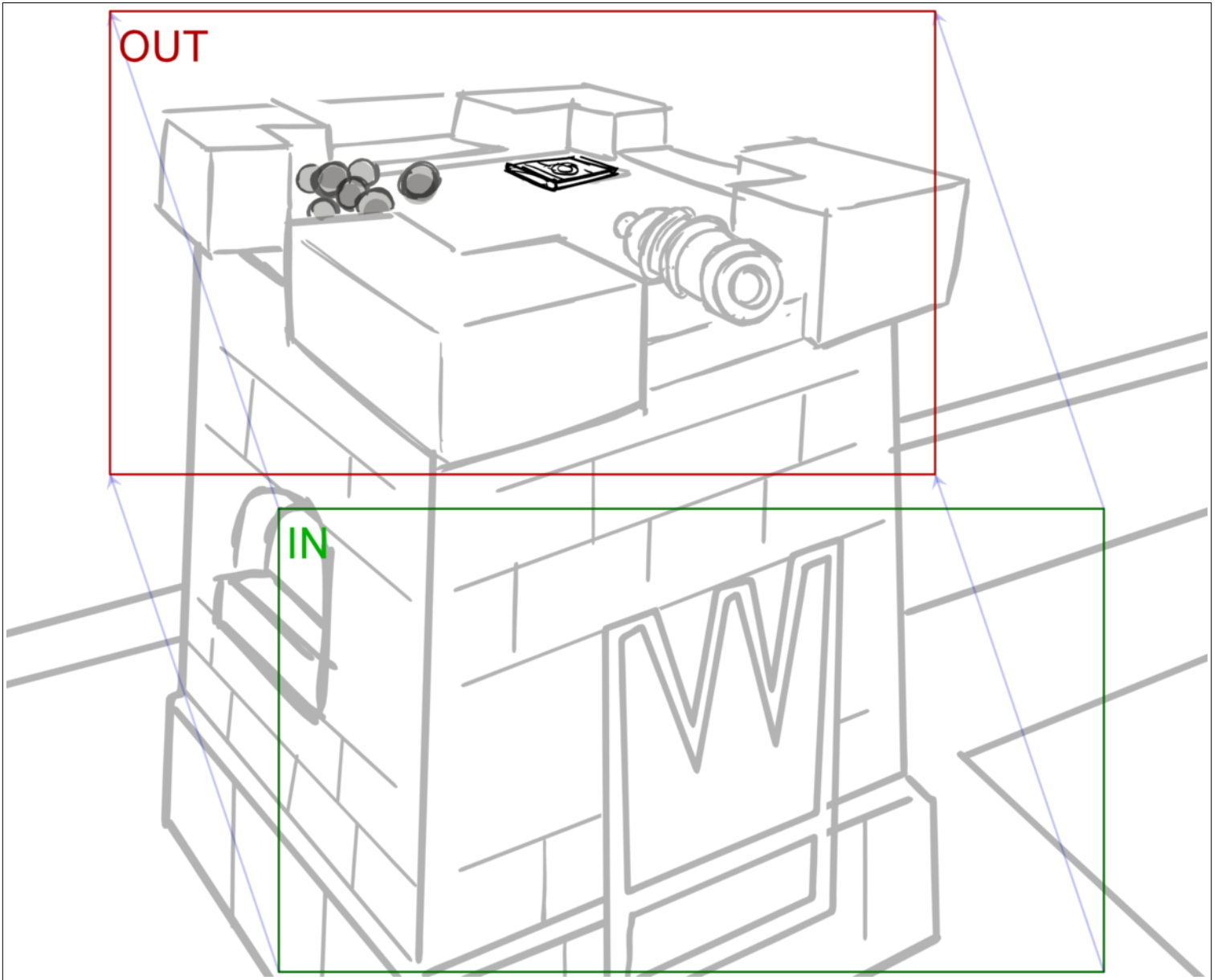

Scene	Duration	Panel	Duration
1	01:17	1	01:03



Action Notes

INT. CLASH ROYALE TOWER - ROOF

Scene	Duration	Panel	Duration
1	01:17	2	00:06

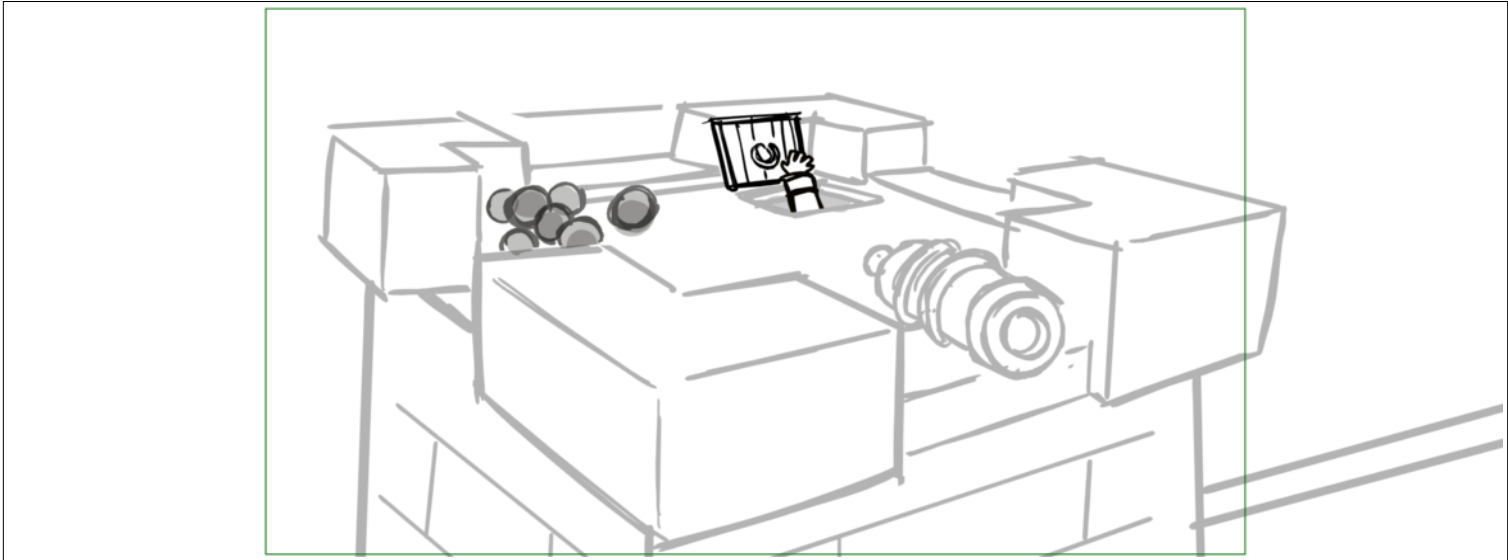

Scene	Duration	Panel	Duration
1	01:17	3	00:08

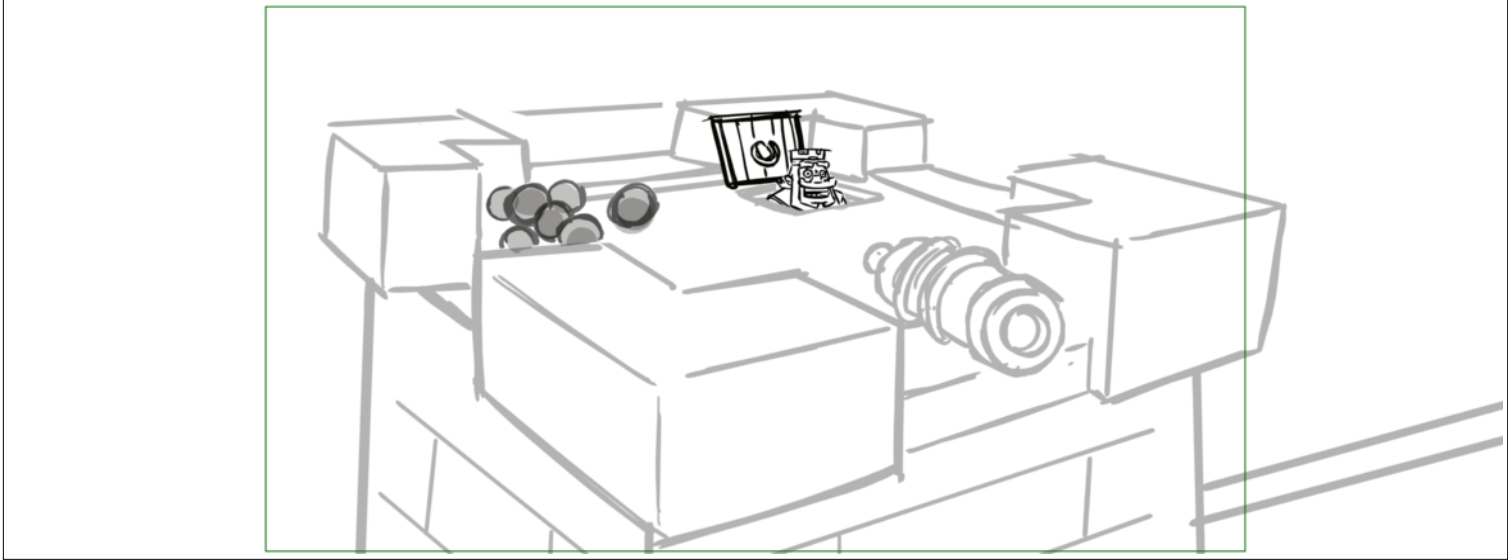

Scene	Duration	Panel	Duration
2	02:19	1	01:01

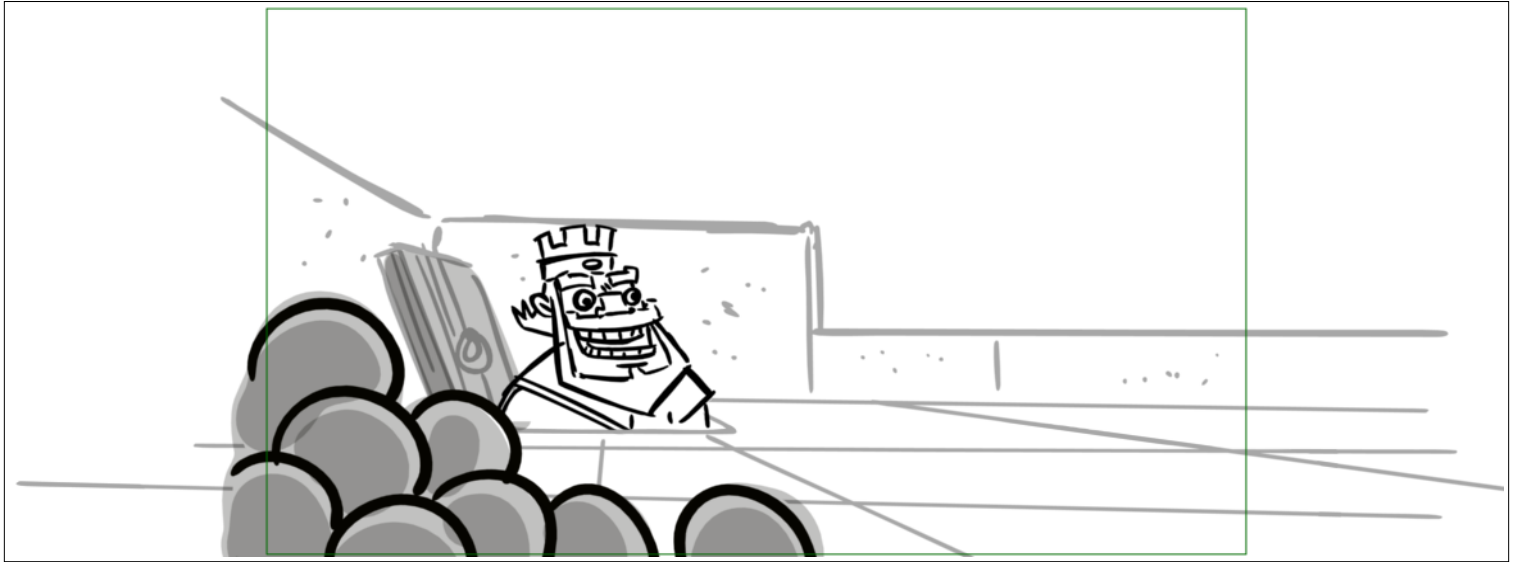

Dialogue

RED KING

*14 Fifty more cannonballs, Leroy!

Notes

START POSE ONLY

Scene	Duration	Panel	Duration
2	02:19	2	00:05

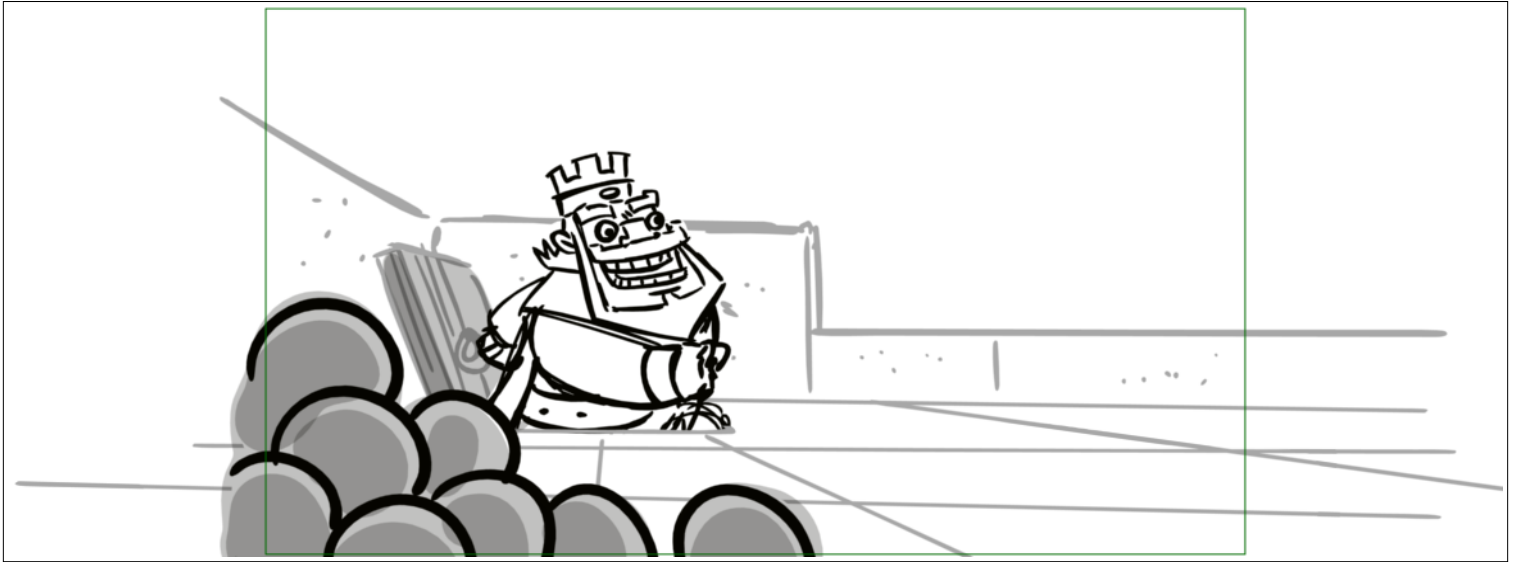

Dialogue

RED KING

*14 Fifty more cannonballs, Leroy!

Scene	Duration	Panel	Duration
2	02:19	3	00:05



Dialogue

RED KING

*14 Fifty more cannonballs, Leroy!

Scene	Duration	Panel	Duration
2	02:19	4	00:05

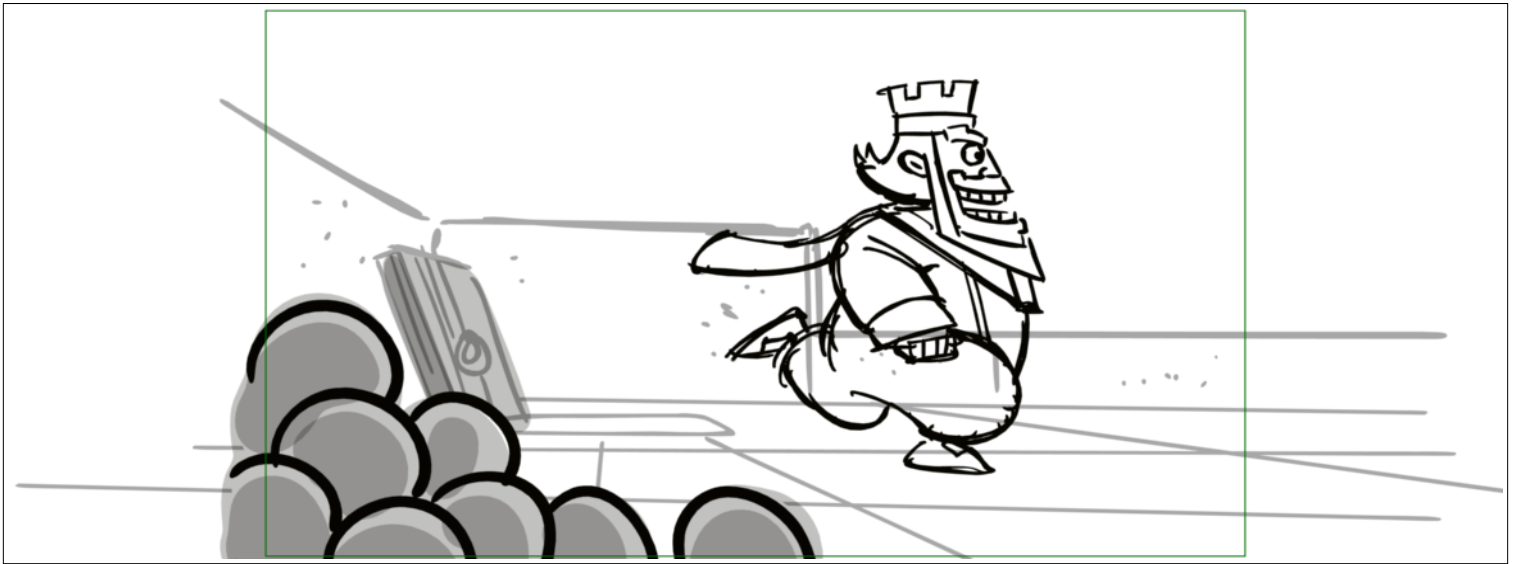

Dialogue

RED KING

*14 Fifty more cannonballs, Leroy!

Scene	Duration	Panel	Duration
2	02:19	5	00:11

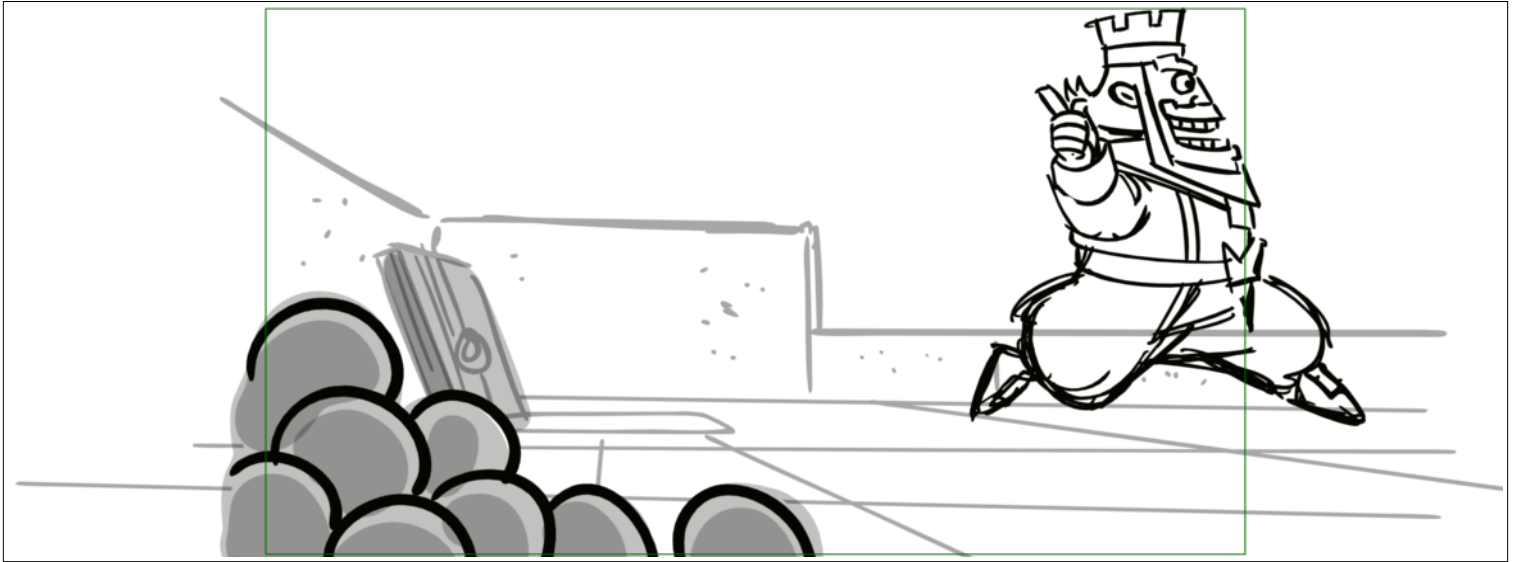

Dialogue

RED KING

*14 Fifty more cannonballs, Leroy!

Scene	Duration	Panel	Duration
2	02:19	6	00:04

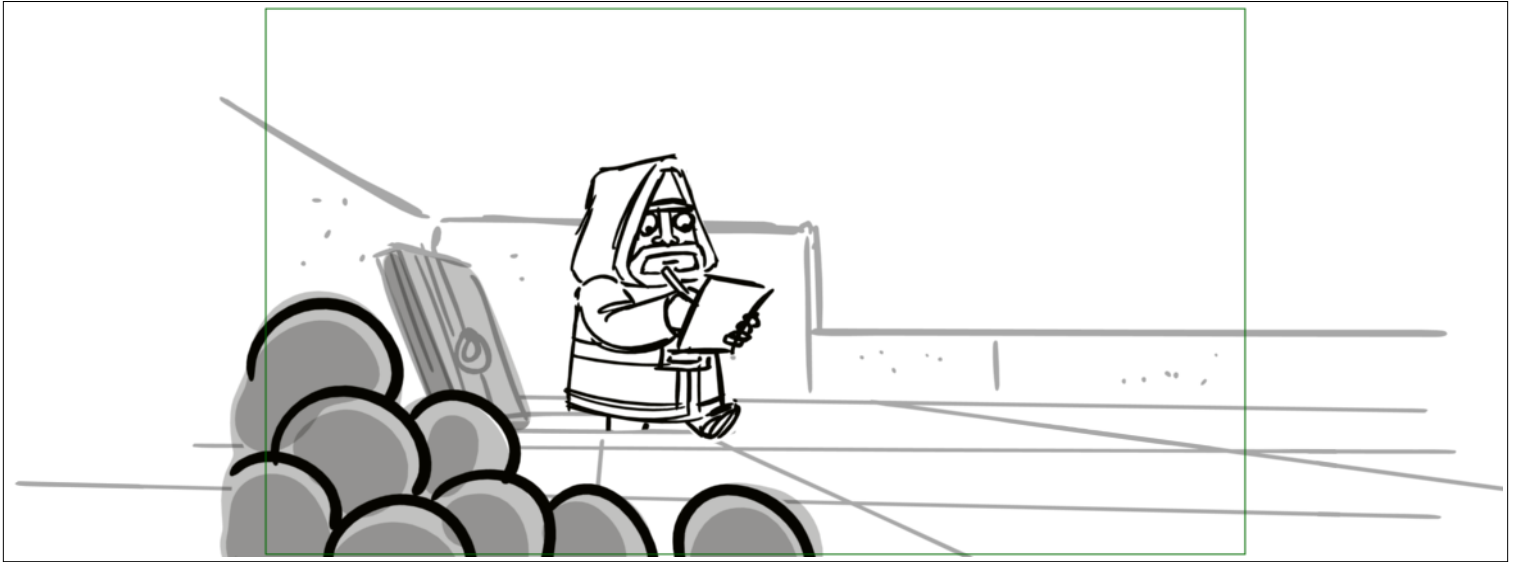

Dialogue

RED KING

*14 Fifty more cannonballs, Leroy!

Scene	Duration	Panel	Duration
2	02:19	7	00:04

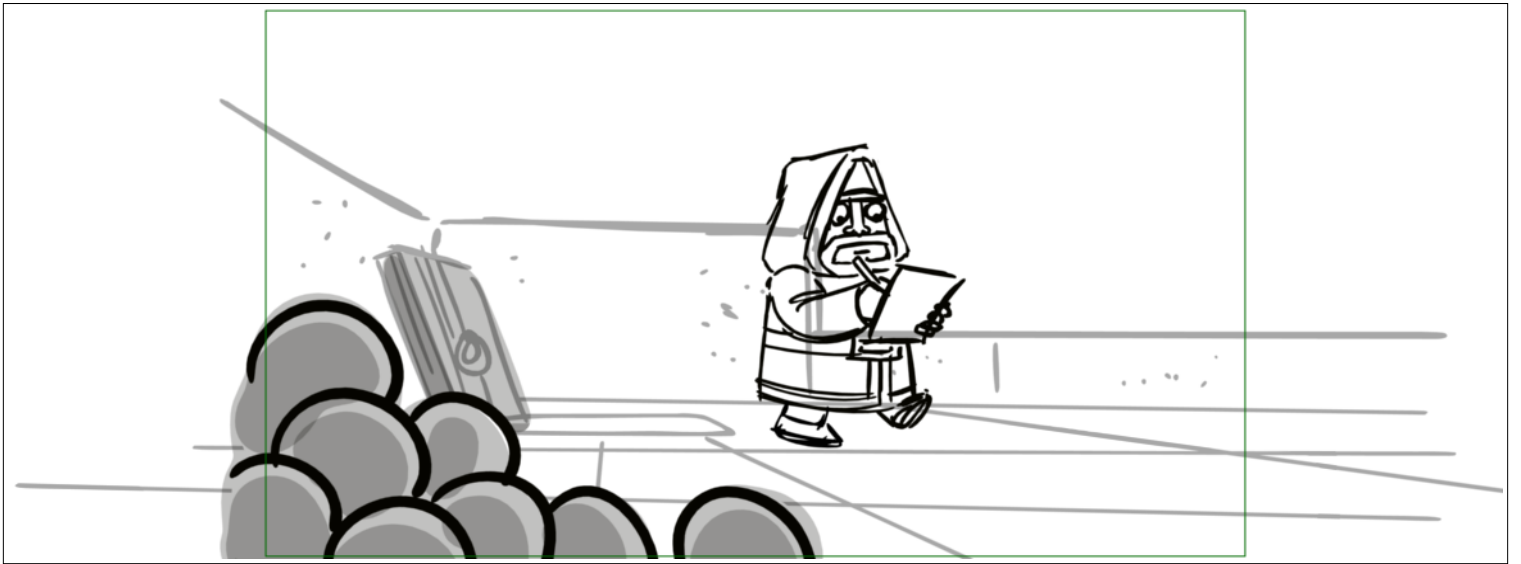

Dialogue

RED KING

*14 Fifty more cannonballs, Leroy!

Scene	Duration	Panel	Duration
2	02:19	8	00:08

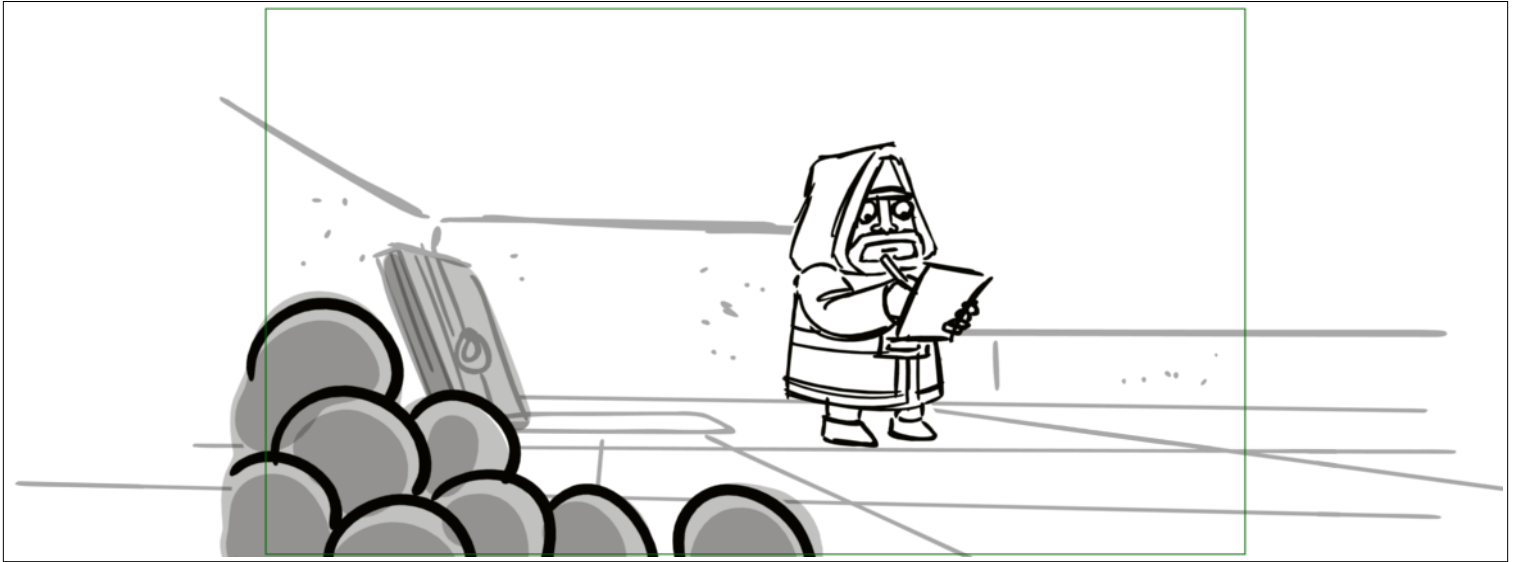

Dialogue

RED KING

*14 Fifty more cannonballs, Leroy!

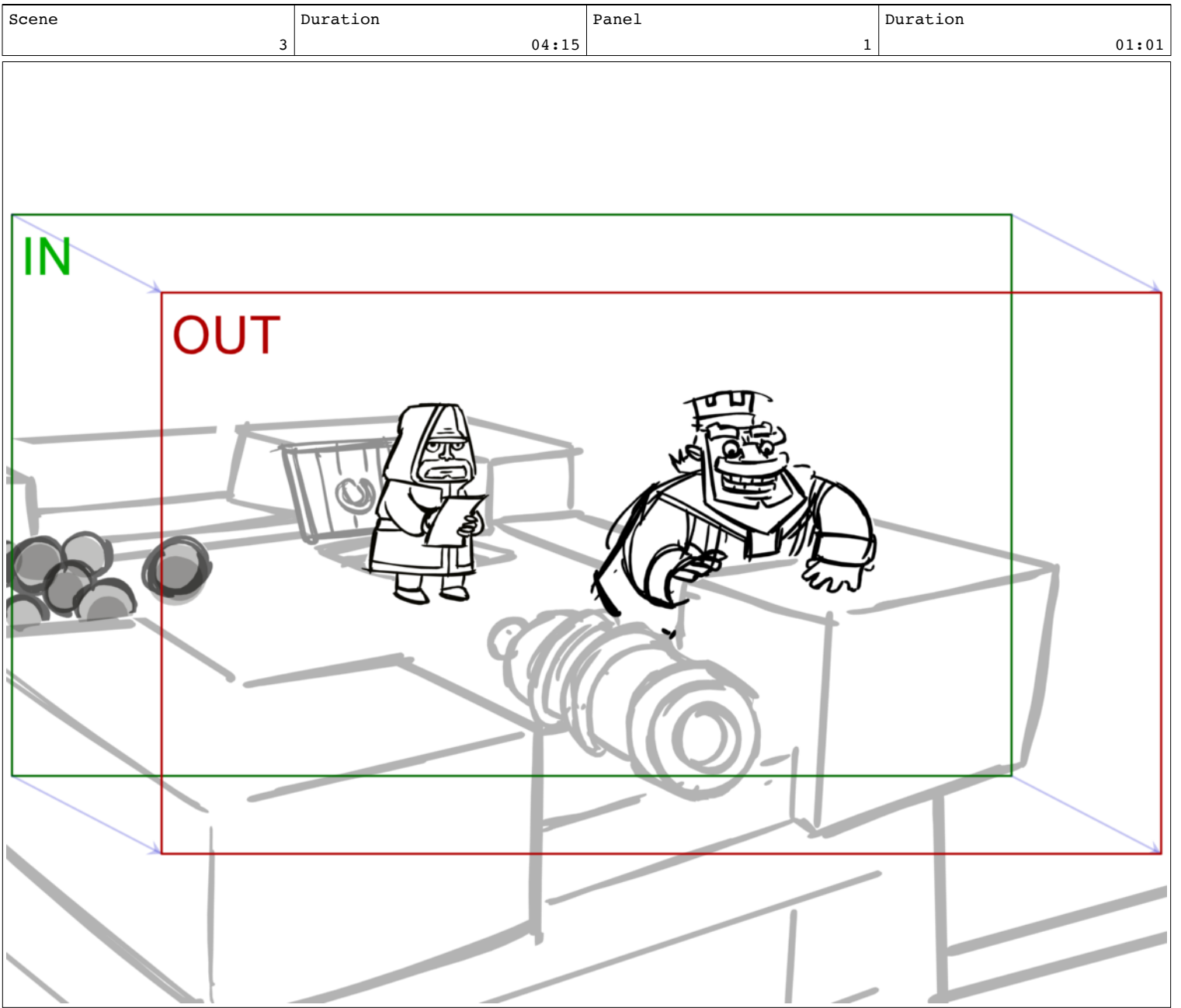

Dialogue

We're preparing for a

Scene	Duration	Panel	Duration
3	04:15	2	00:17

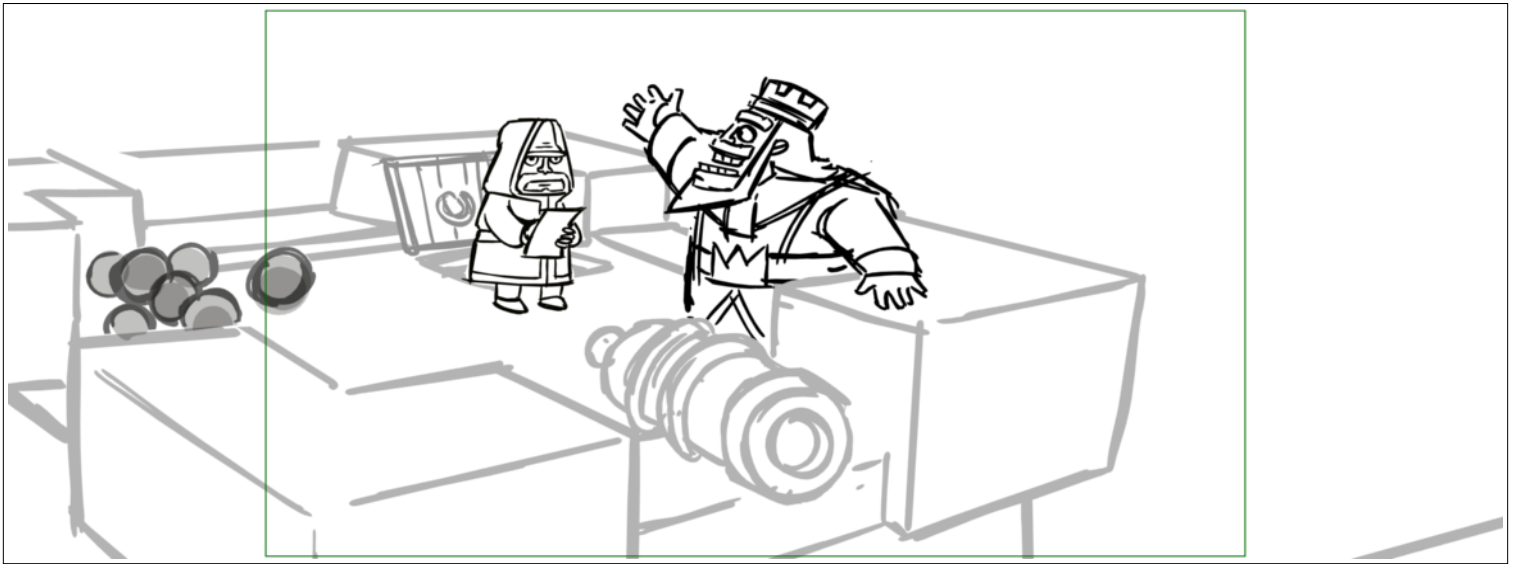

Dialogue
battle,

Scene	Duration	Panel	Duration
3	04:15	3	00:14

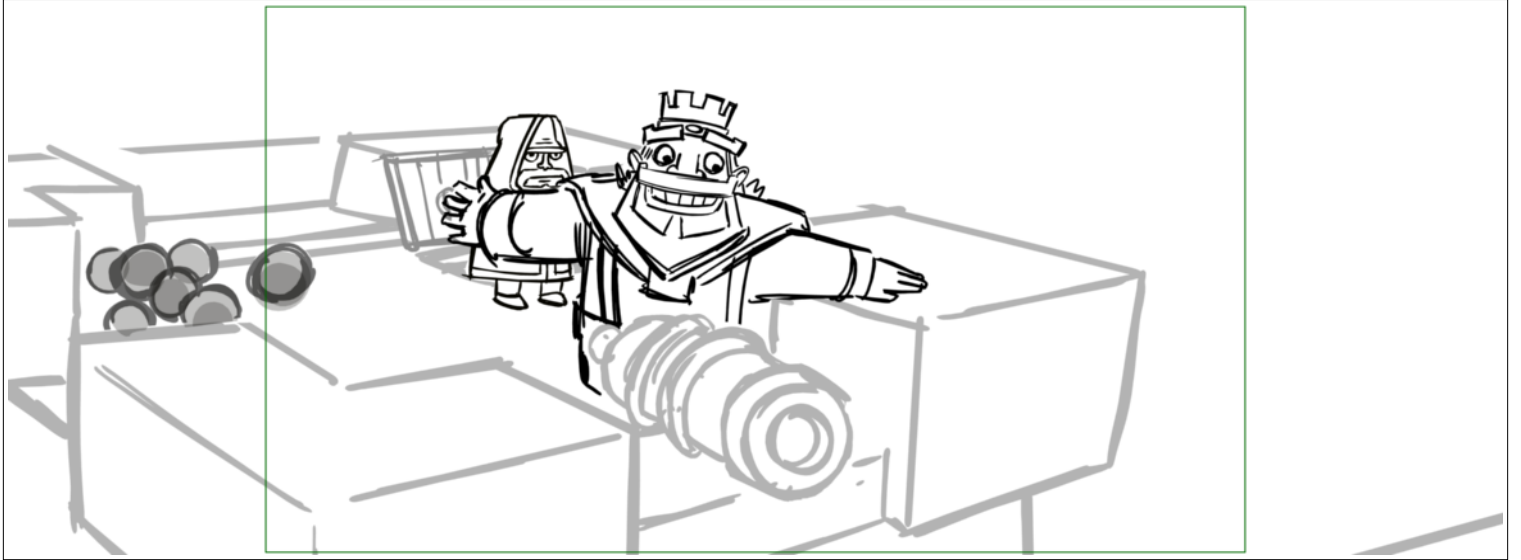

Dialogue
not a

Scene	Duration	Panel	Duration
3	04:15	4	01:12

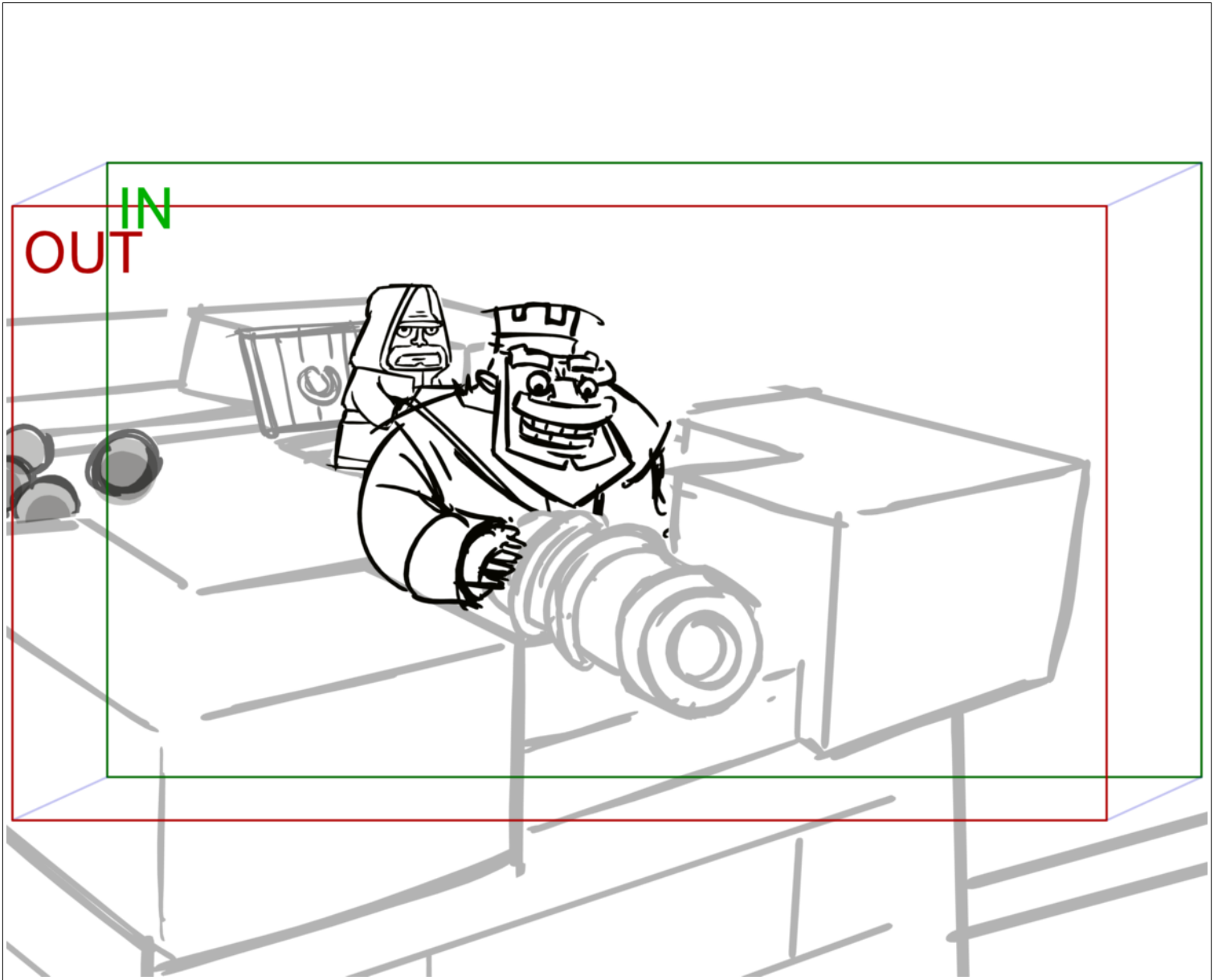

Dialogue

cheese tasting!

Scene	Duration	Panel	Duration
3	04:15	5	00:19

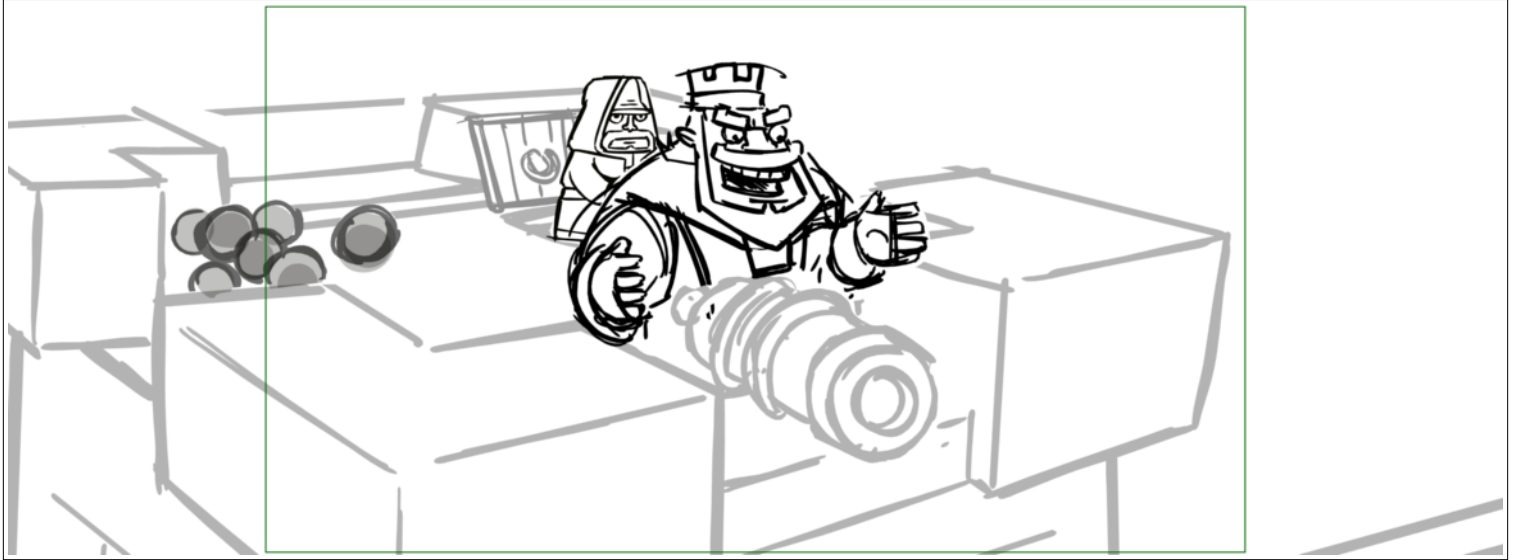

Dialogue

RED KING (CONT'D)

15 UPGRADE

Scene	Duration	Panel	Duration
4	01:17	1	01:17

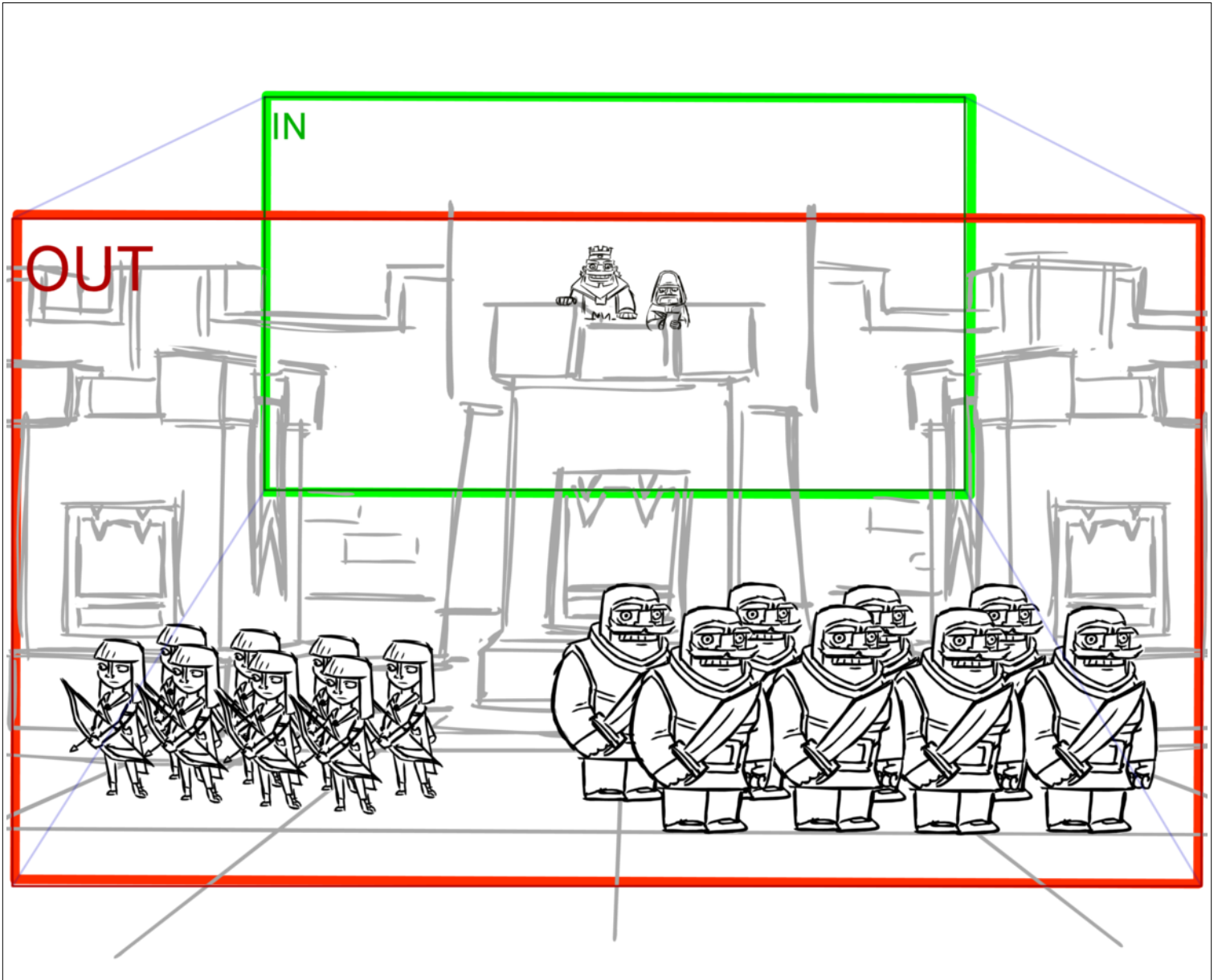

Dialogue

THE KNIGHT AND ARCHERS,

Scene	Duration	Panel	Duration
5	03:01	1	00:08

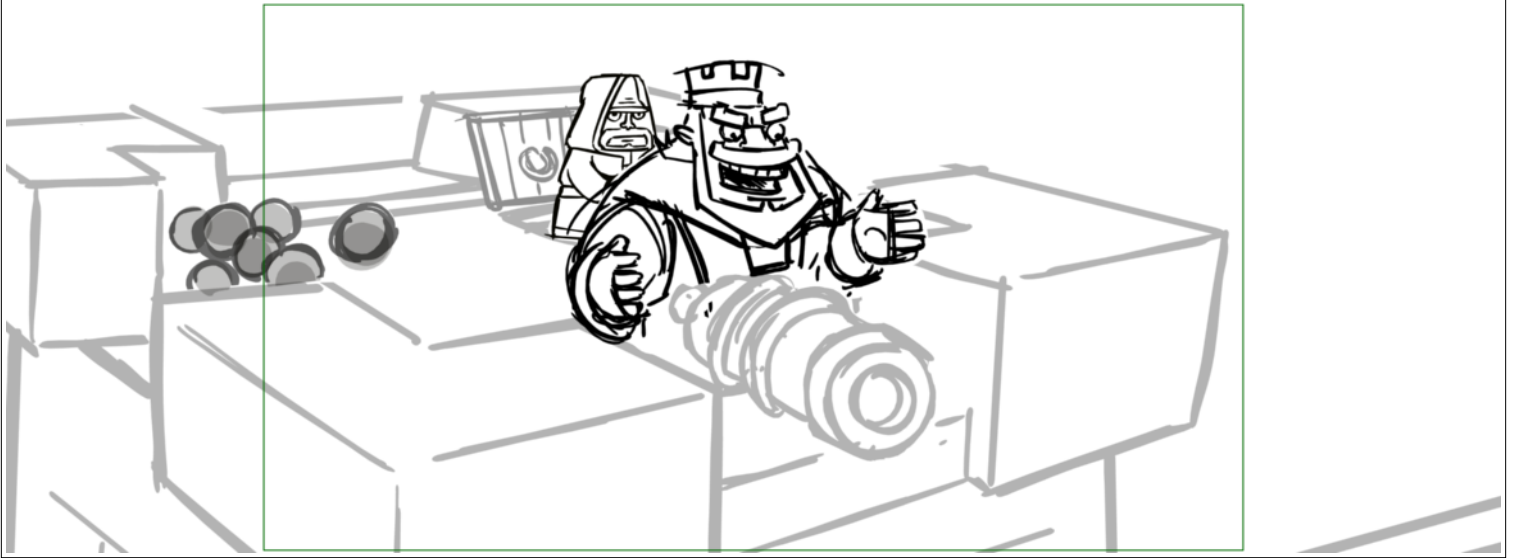

Dialogue

RED KING (CONT'D)

THIS RIGHT HERE IS WAR!

Scene	Duration	Panel	Duration
5	03:01	2	00:06

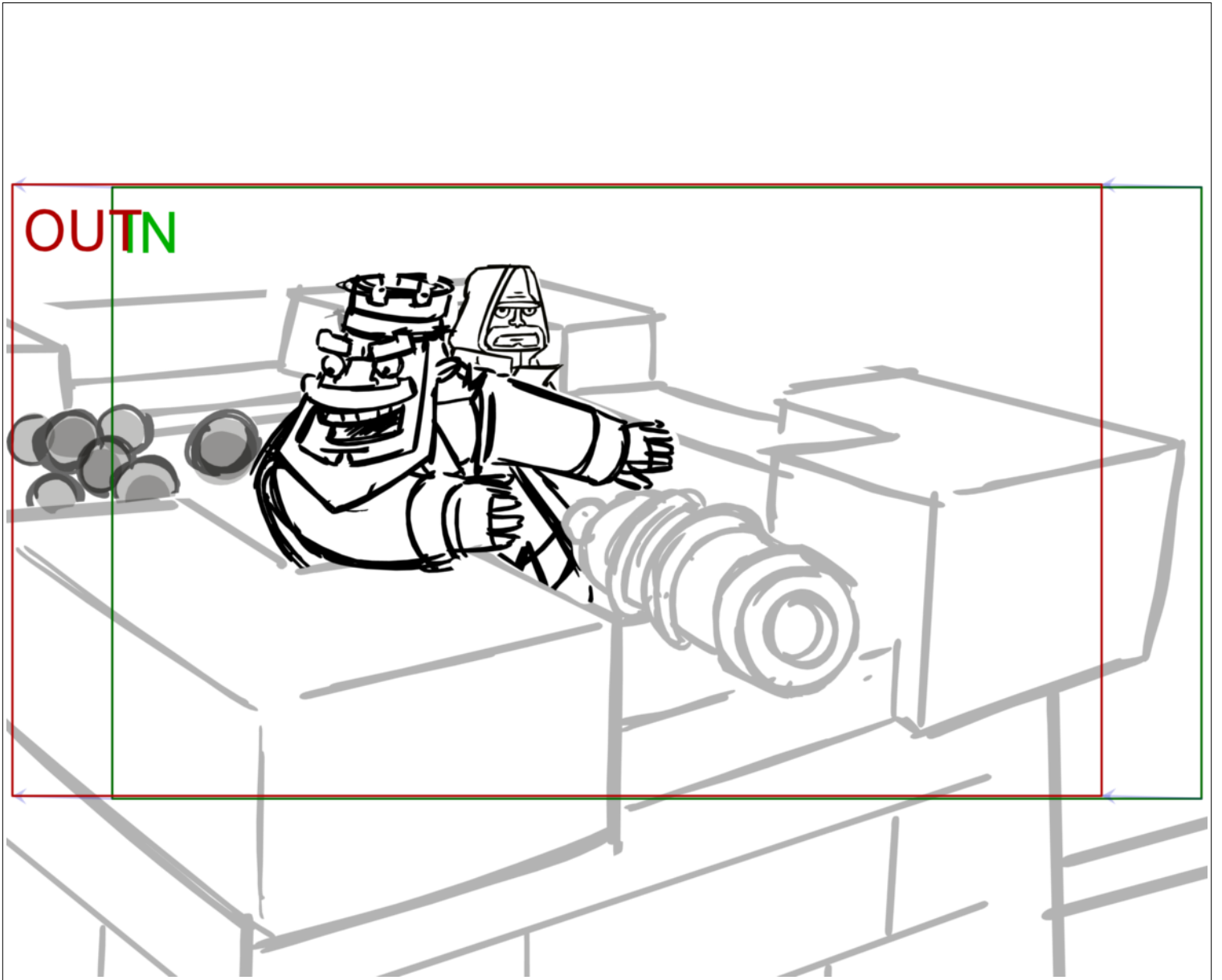

Dialogue

RED KING (CONT'D)

THIS RIGHT HERE IS WAR!

Scene	Duration	Panel	Duration
5	03:01	3	00:18

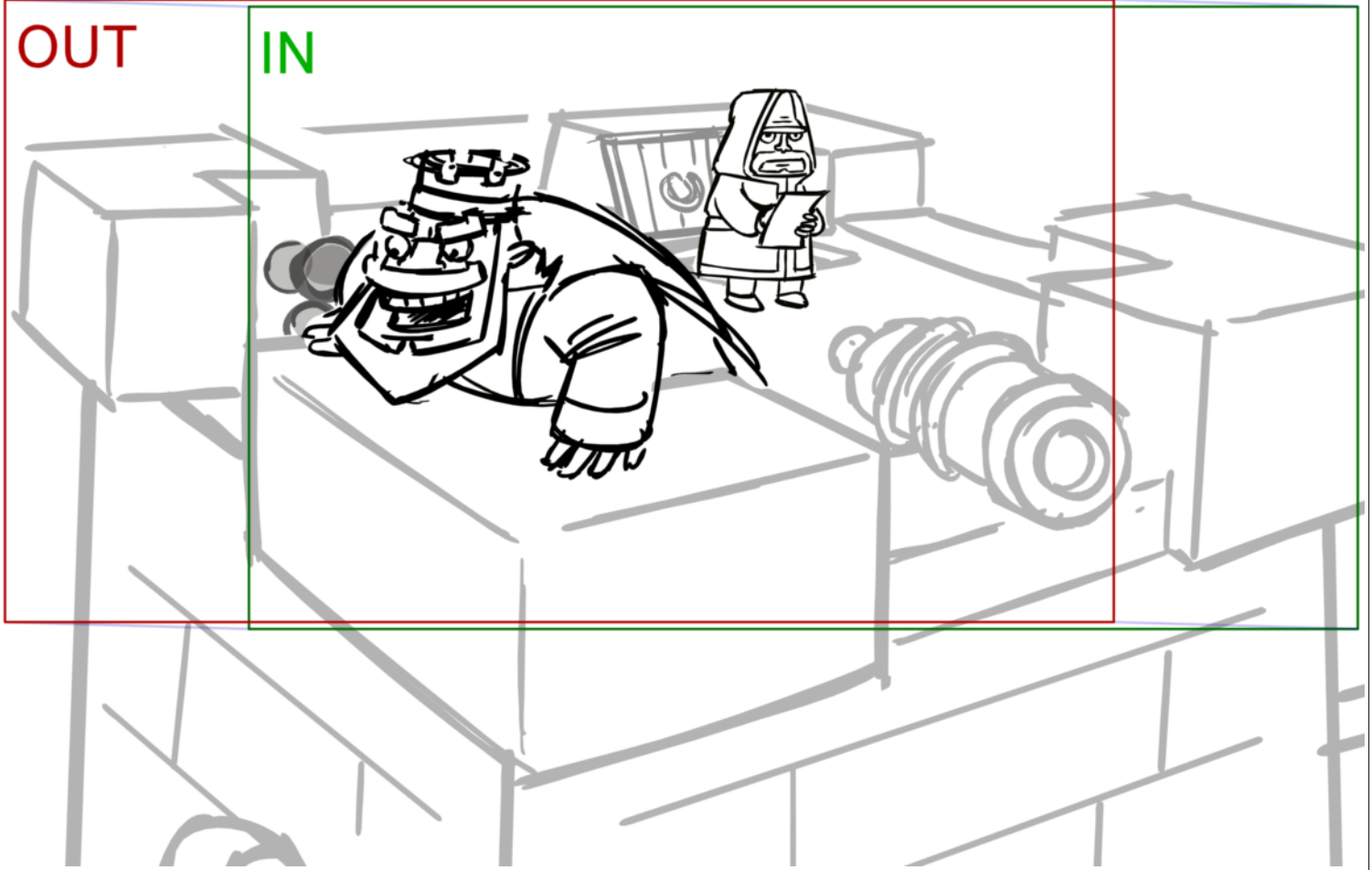

Dialogue

RED KING (CONT'D)

THIS RIGHT HERE IS WAR!

Scene	Duration	Panel	Duration
5	03:01	4	01:06



Dialogue

RED KING (CONT'D)

THIS RIGHT HERE IS WAR!

Scene	Duration	Panel	Duration
5	03:01	5	00:11

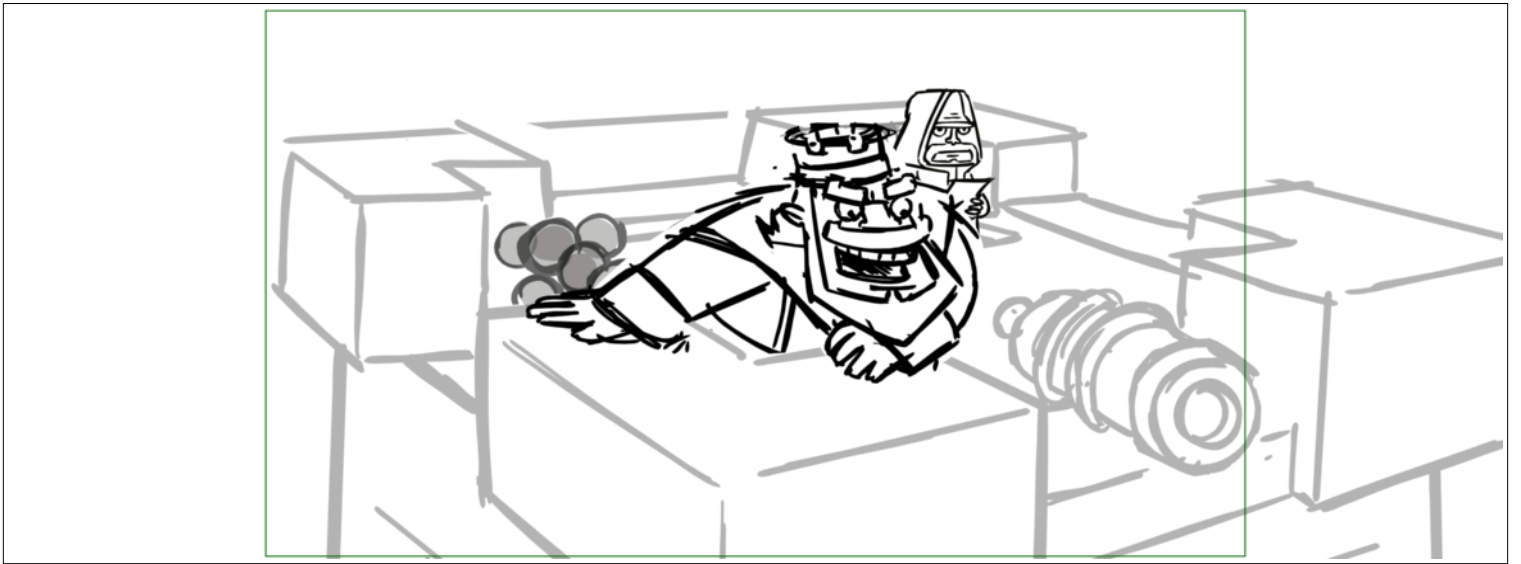

Dialogue

RED KING (CONT'D)

TESLAS,

Scene	Duration	Panel	Duration
6	01:07	1	00:16

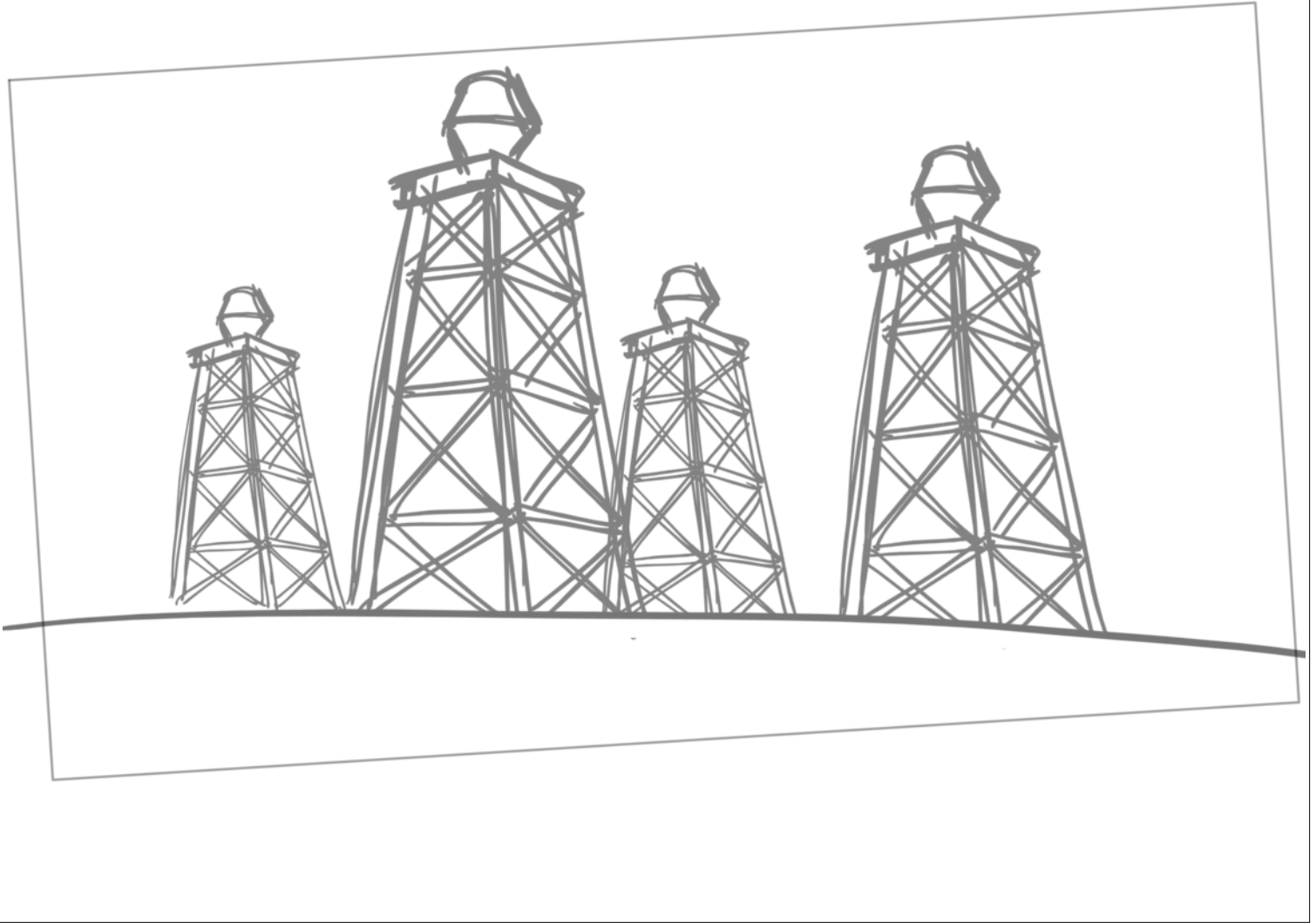

Dialogue

RED KING (CONT'D)

MINIONS

Notes

CYCLE THIS PANEL AND NEXT AS NEEDED

Scene	Duration	Panel	Duration
6	01:07	2	00:08

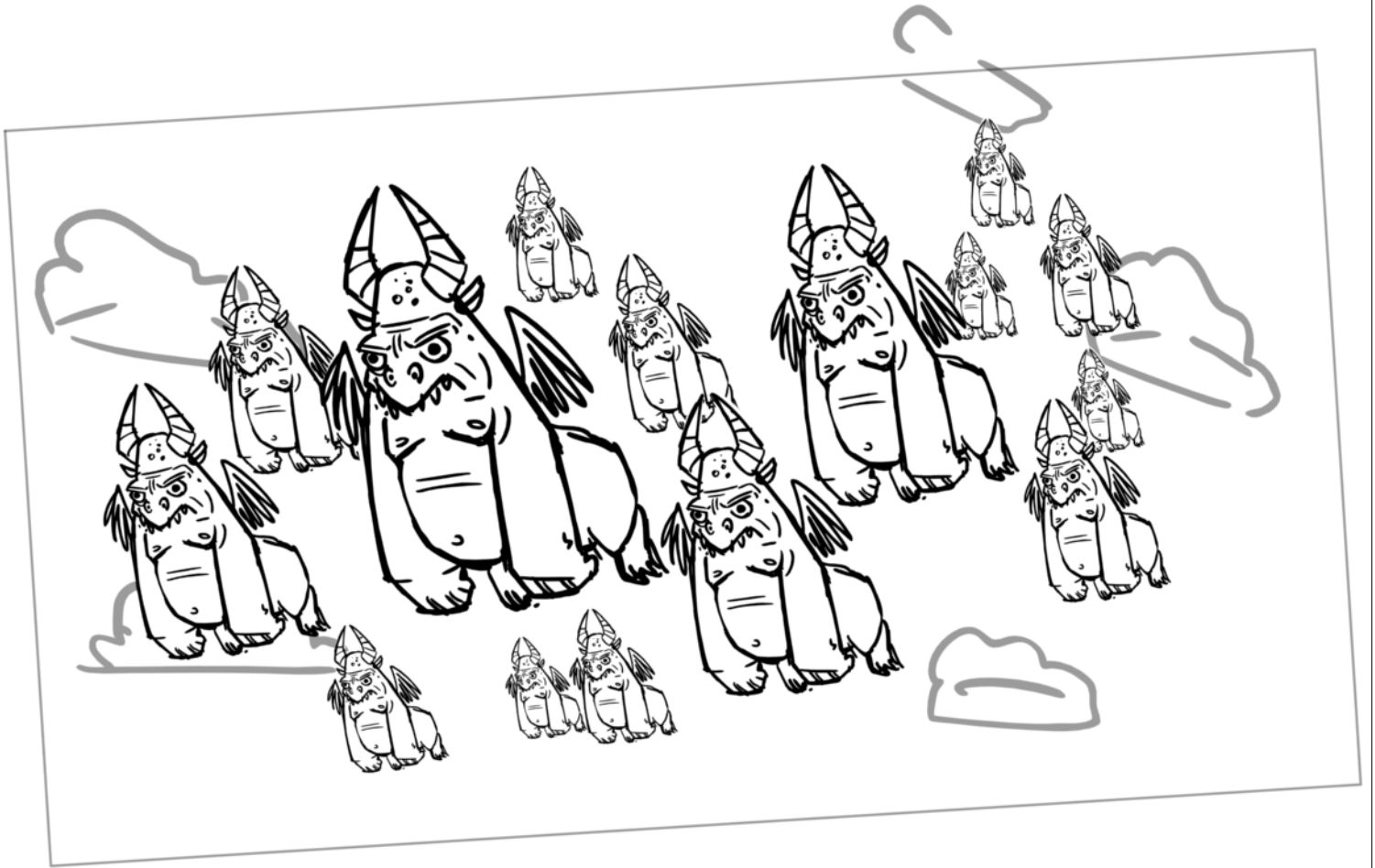

Dialogue

RED KING (CONT'D)

MINIONS

Notes

CYCLE THIS PANEL AND NEXT AS NEEDED

Scene	Duration	Panel	Duration
6	01:07	3	00:07



Dialogue

RED KING (CONT'D)

MINIONS

Notes

CYCLE THIS PANEL AND PREVIOUS AS NEEDED

Scene	Duration	Panel	Duration
7	01:01	1	00:14



Dialogue

RED KING (CONT'D)

FIREBALLS

Scene	Duration	Panel	Duration
7	01:01	2	00:11



Dialogue

RED KING (CONT'D)

FIREBALLS

Scene	Duration	Panel	Duration
8	02:00	1	00:10

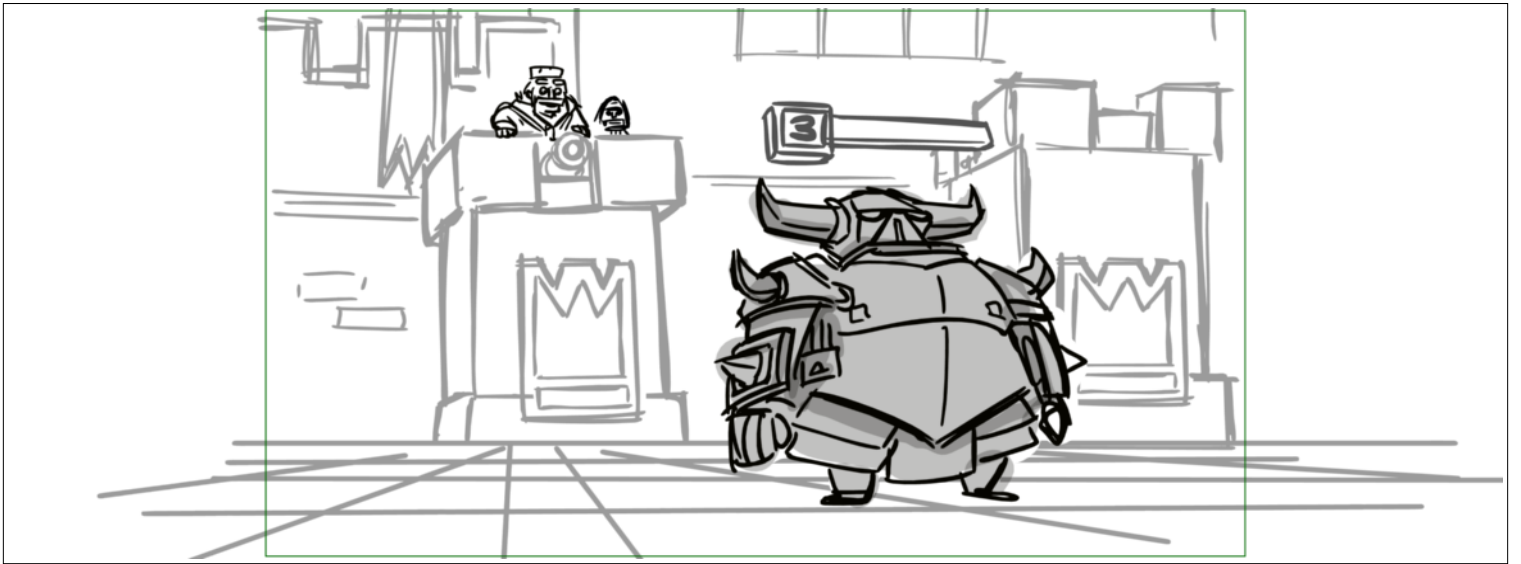

Dialogue

RED KING (CONT'D)

THAT P.E.K.K.A.'S NOW A LEVEL FOUR!

Scene	Duration	Panel	Duration
8	02:00	2	00:09

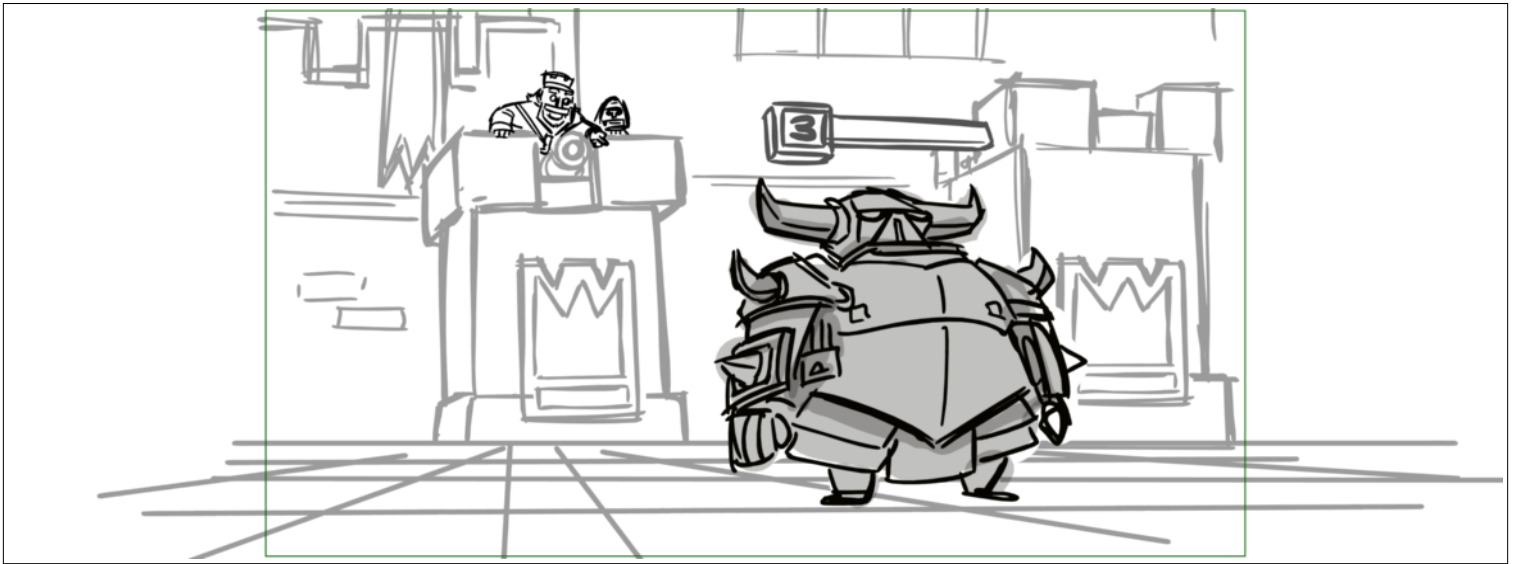

Dialogue

RED KING (CONT'D)

THAT P.E.K.K.A.'S NOW A LEVEL FOUR!

Scene	Duration	Panel	Duration
8	02:00	3	00:04

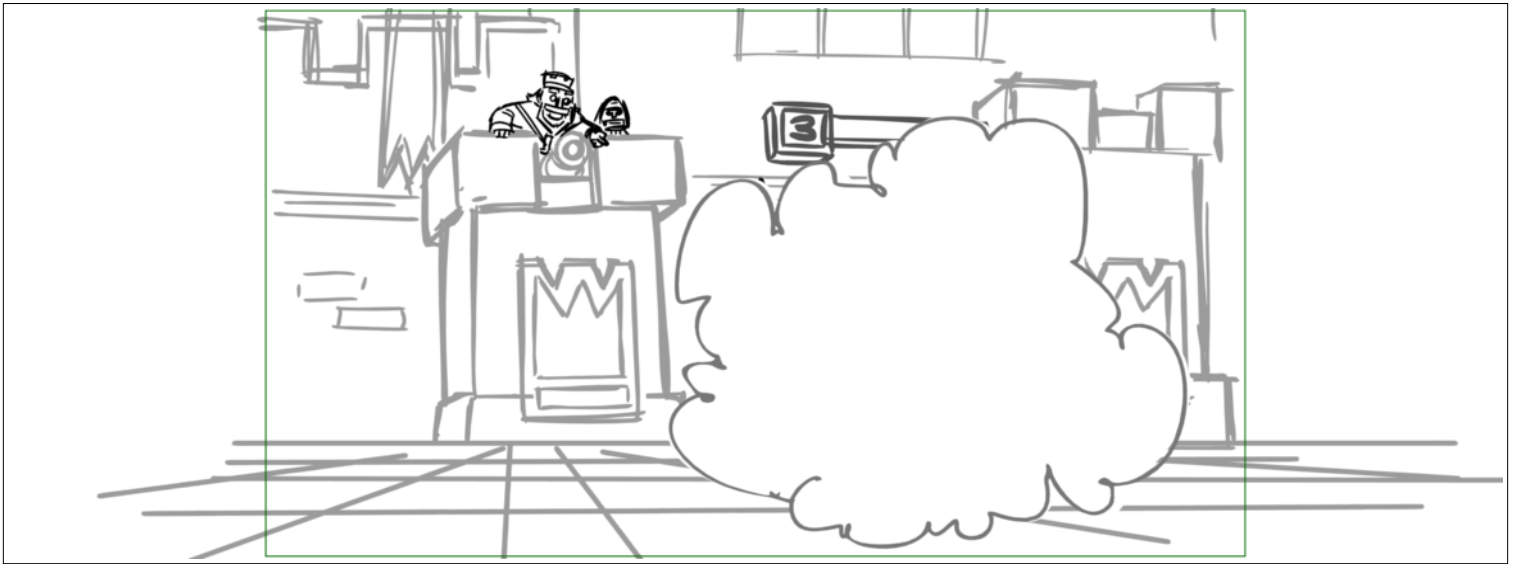

Dialogue

RED KING (CONT'D)

THAT P.E.K.K.A.'S NOW A LEVEL FOUR!

Scene	Duration	Panel	Duration
8	02:00	4	00:03

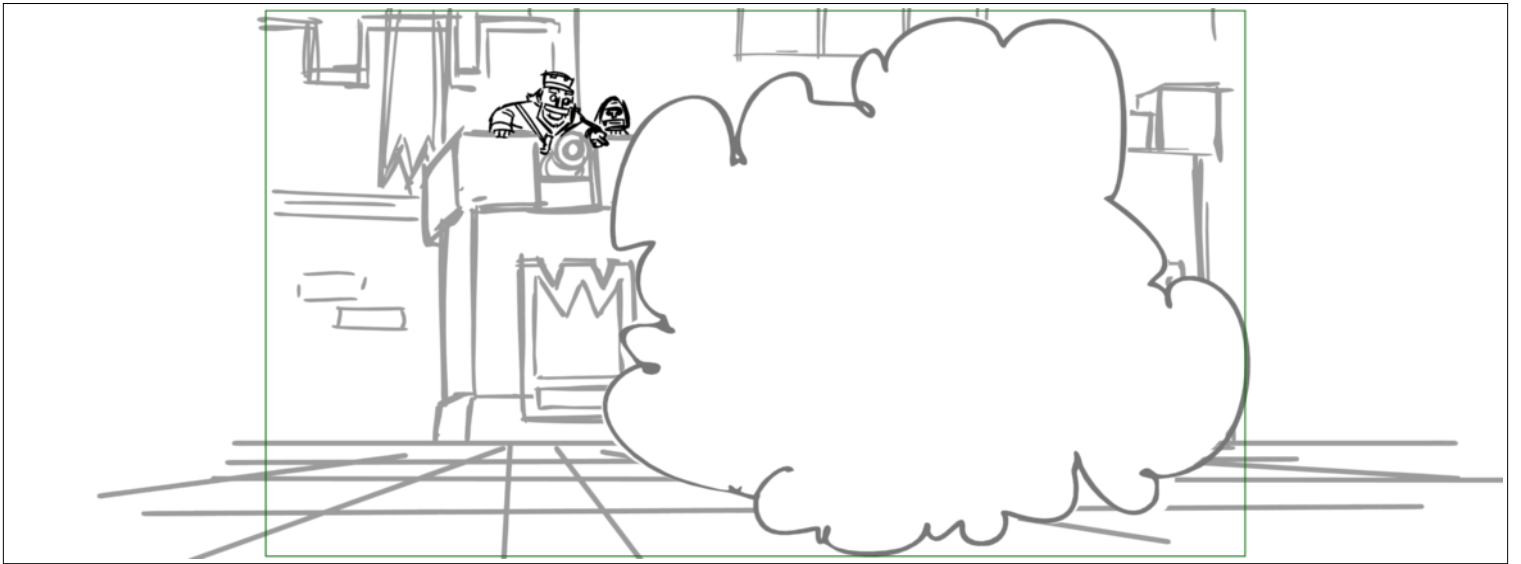

Dialogue

RED KING (CONT'D)

THAT P.E.K.K.A.'S NOW A LEVEL FOUR!

Scene	Duration	Panel	Duration
8	02:00	5	00:04

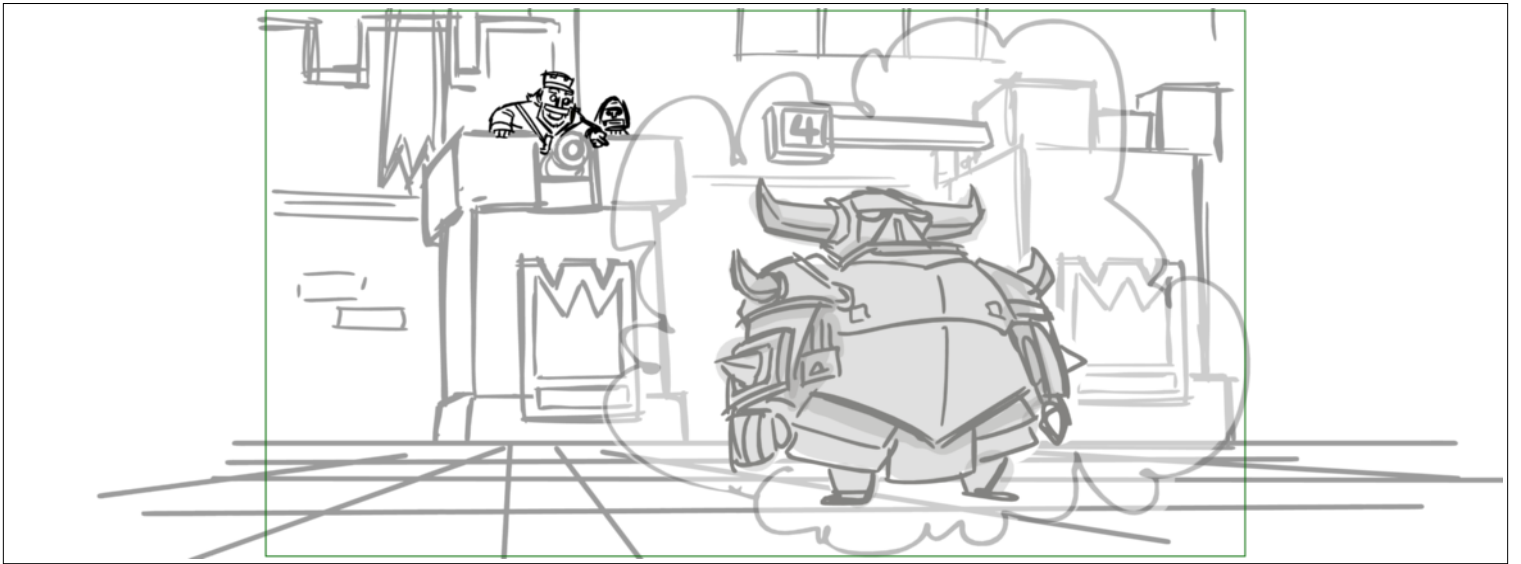

Dialogue

RED KING (CONT'D)

THAT P.E.K.K.A.'S NOW A LEVEL FOUR!

Scene	Duration	Panel	Duration
8	02:00	6	00:04

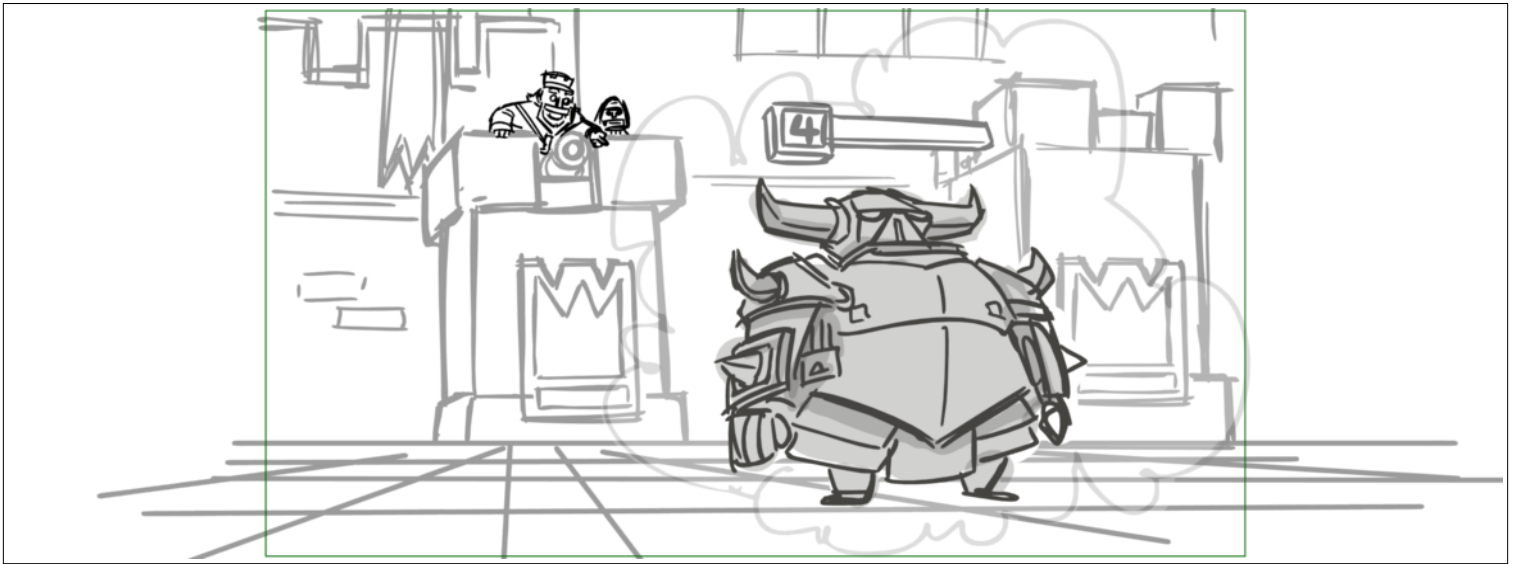

Dialogue

RED KING (CONT'D)

THAT P.E.K.K.A.'S NOW A LEVEL FOUR!

Scene	Duration	Panel	Duration
8	02:00	7	00:07

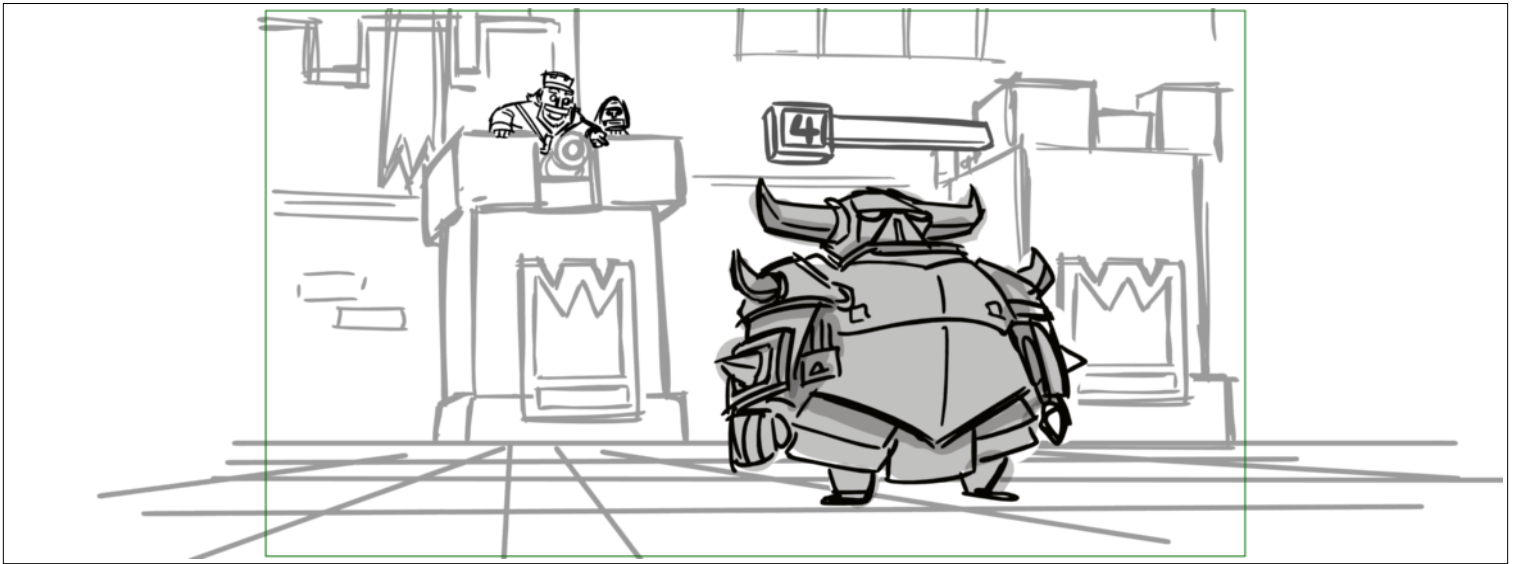

Dialogue

RED KING (CONT'D)

THAT P.E.K.K.A.'S NOW A LEVEL FOUR!

Scene	Duration	Panel	Duration
8	02:00	8	00:07

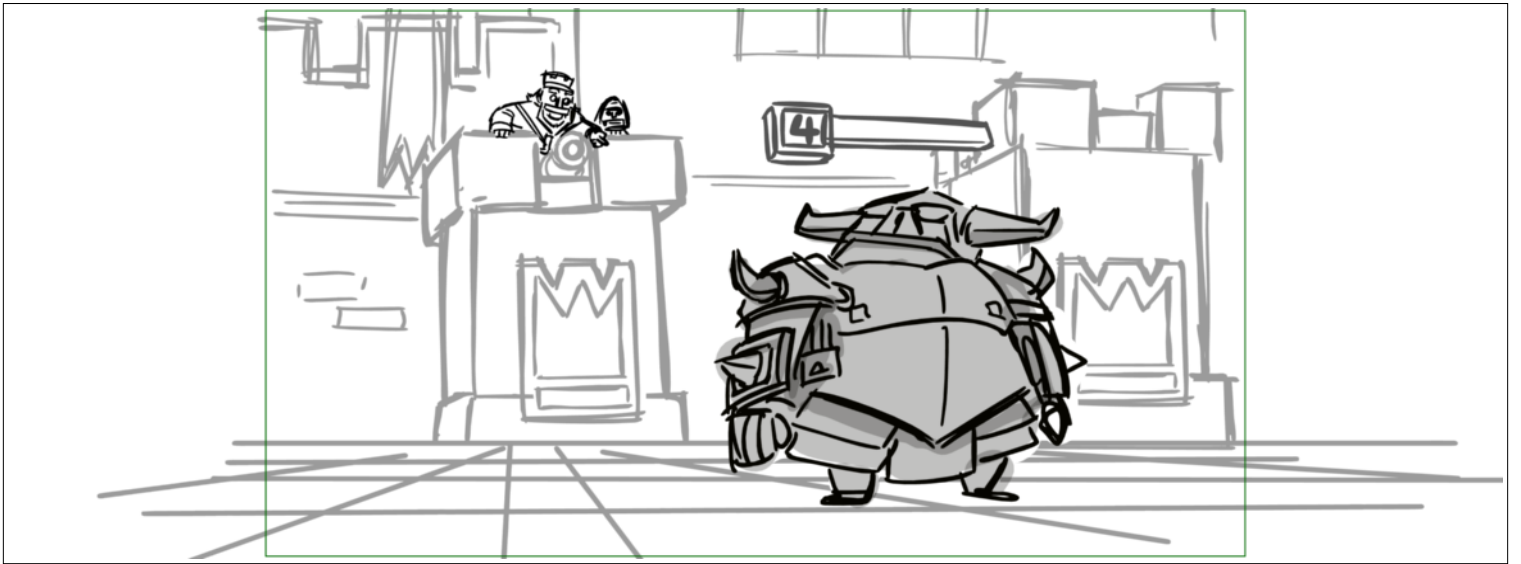

Dialogue

RED KING (CONT'D)

THAT P.E.K.K.A.'S NOW A LEVEL FOUR!

Scene	Duration	Panel	Duration
9	05:03	1	00:05

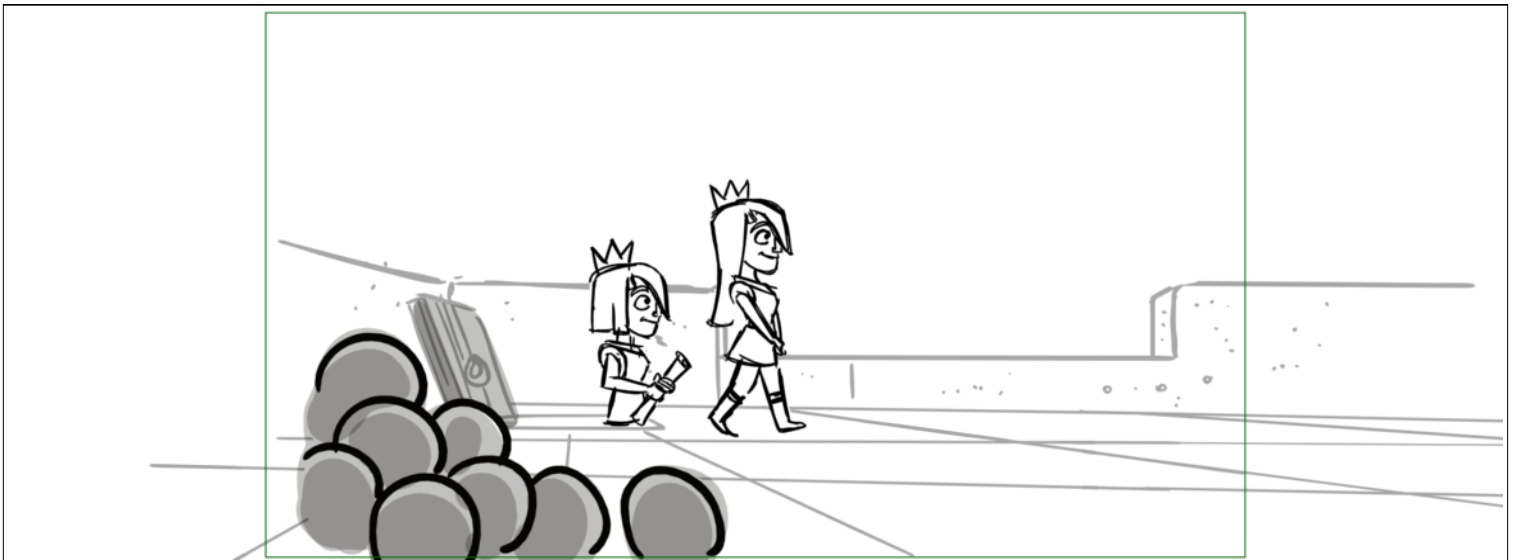

Scene	Duration	Panel	Duration
9	05:03	2	00:05

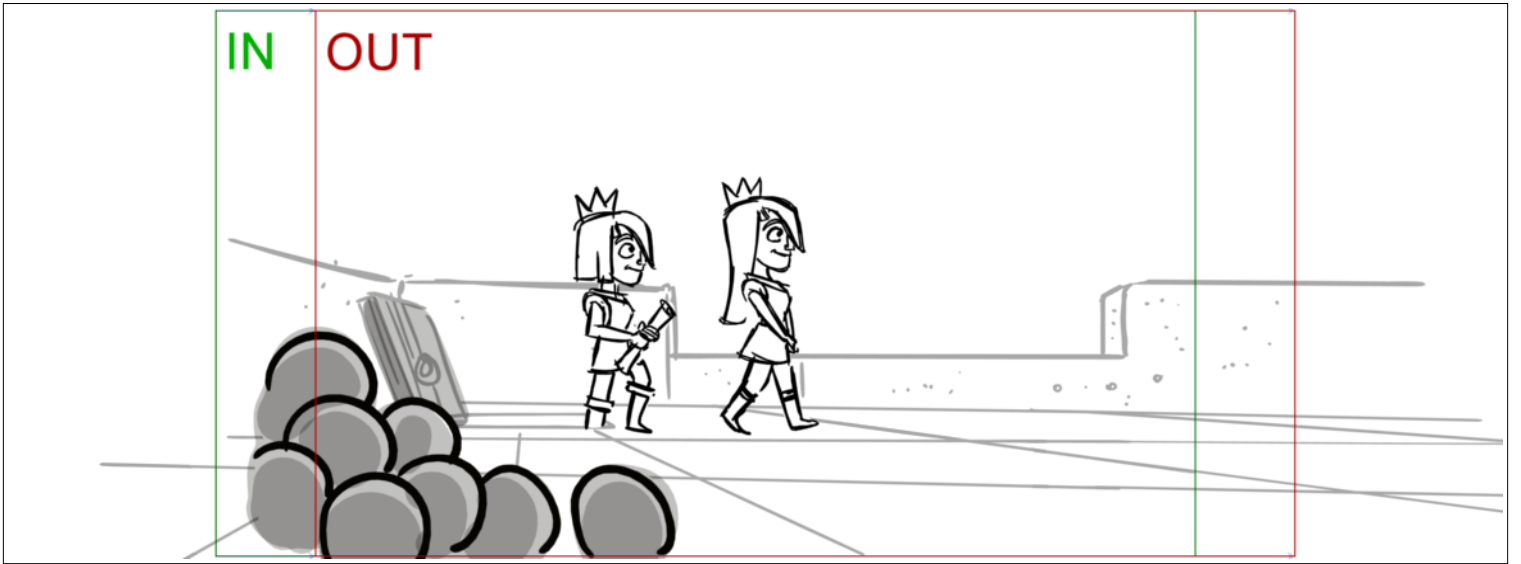

Scene	Duration	Panel	Duration
9	05:03	3	00:05

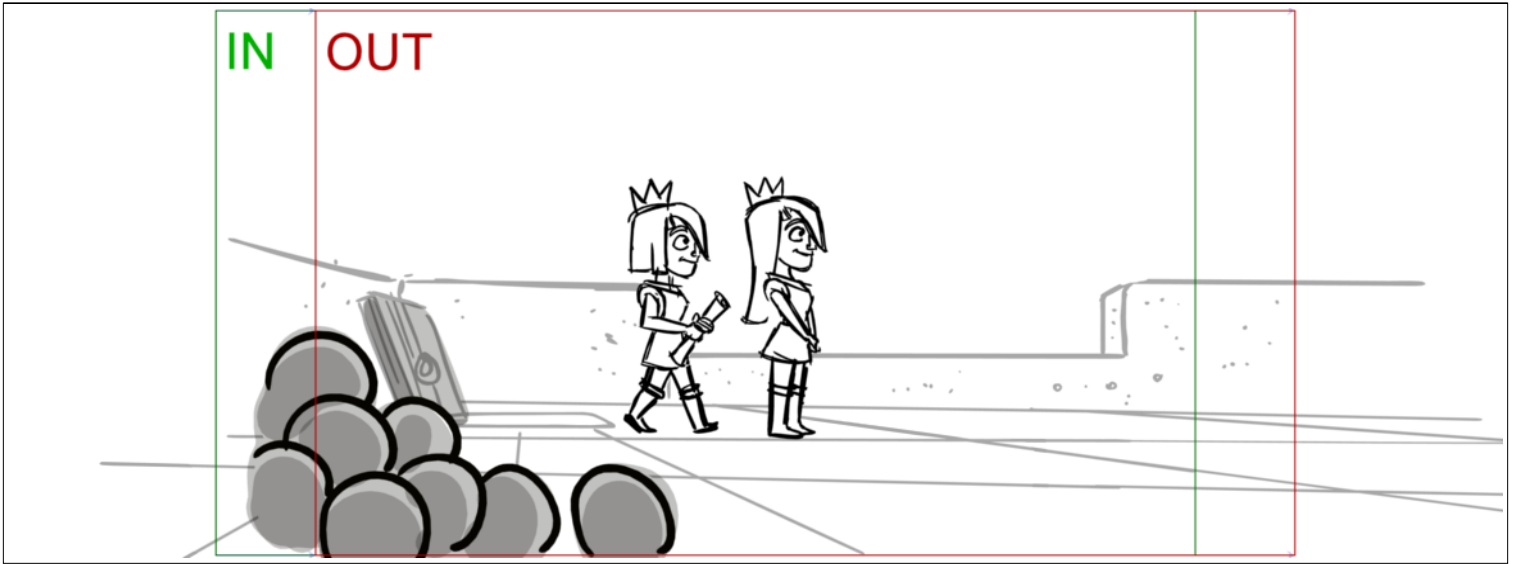

Scene	Duration	Panel	Duration
9	05:03	4	00:05

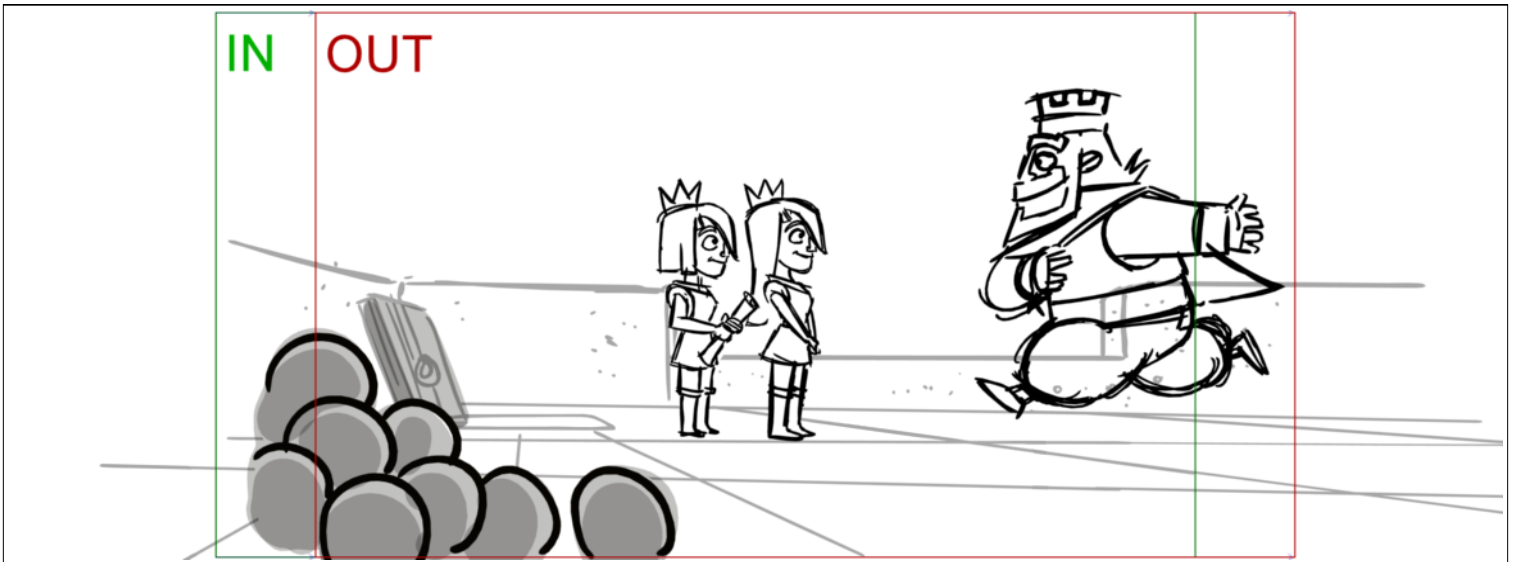

Scene	Duration	Panel	Duration
9	05:03	5	00:08

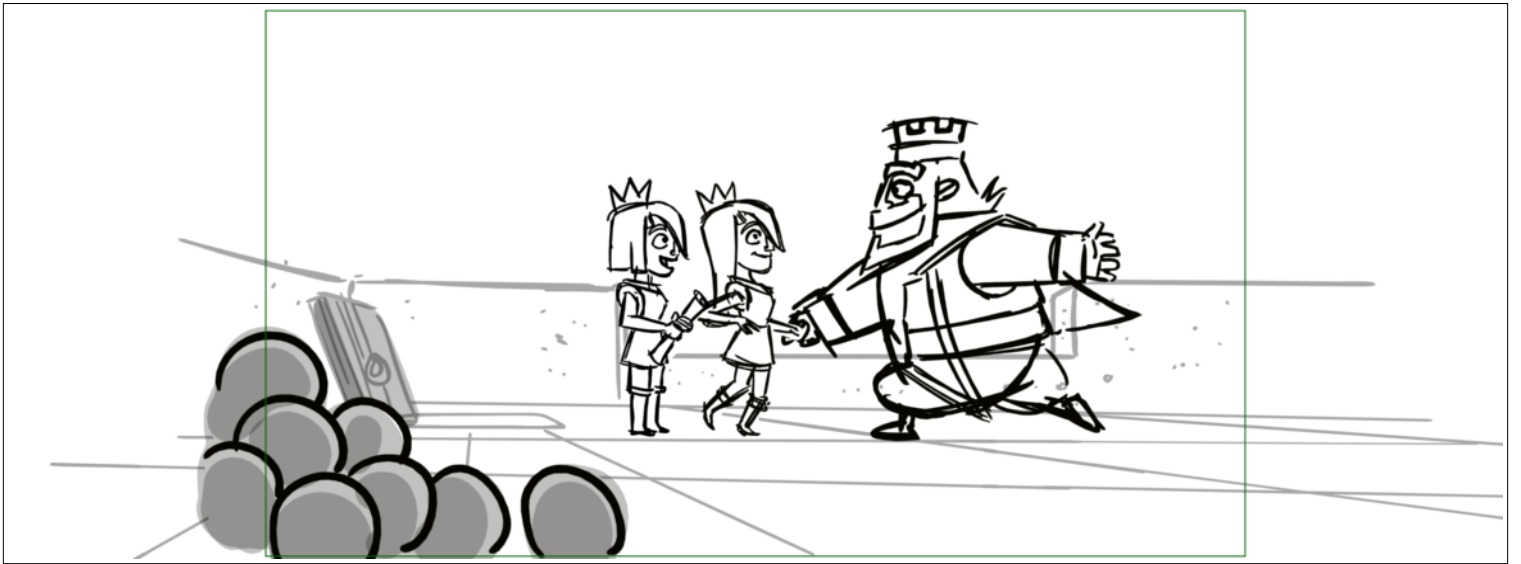

Dialogue

ANNIE

19 Hey Dad, oh,

Scene	Duration	Panel	Duration
9	05:03	6	00:06

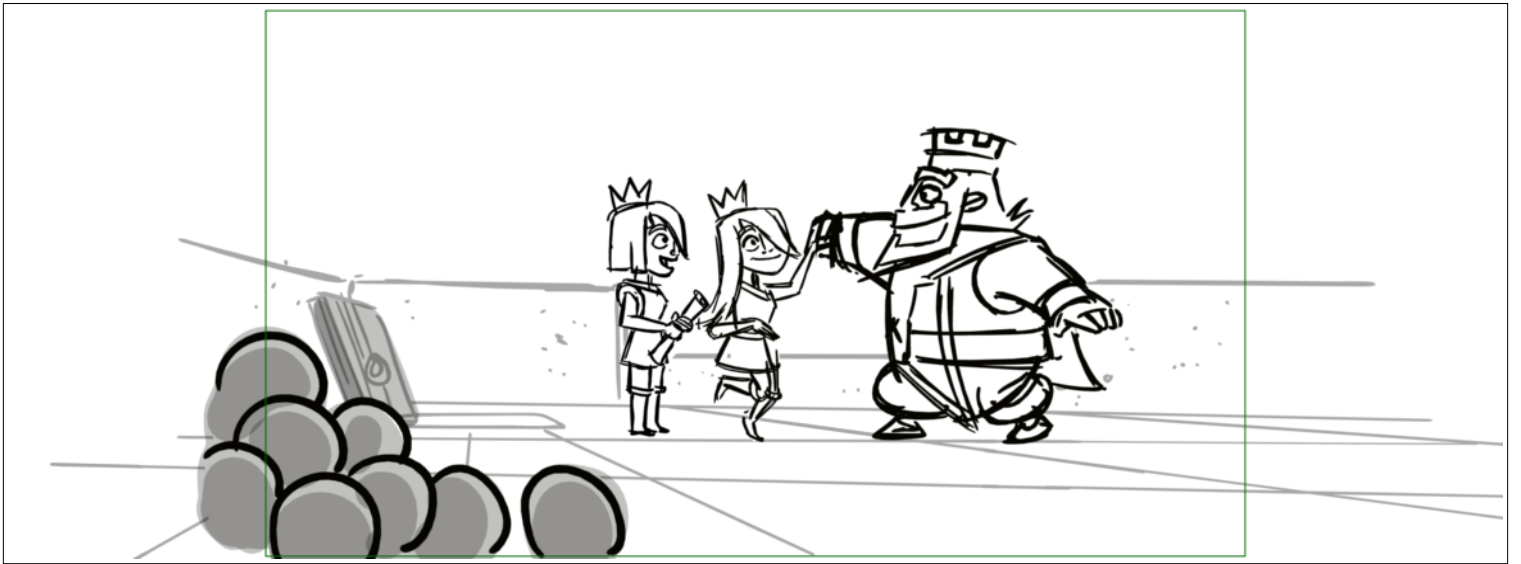

Dialogue

ANNIE

19 Hey Dad, oh,

Scene	Duration	Panel	Duration
9	05:03	7	00:06



Dialogue

ANNIE

19 Hey Dad, oh,

Scene	Duration	Panel	Duration
9	05:03	8	00:06



Dialogue

ANNIE

19 Hey Dad, oh,

Scene	Duration	Panel	Duration
9	05:03	9	00:06



Dialogue

ANNIE

19 Hey Dad, oh,

Scene	Duration	Panel	Duration
9	05:03	10	00:06



Dialogue

ANNIE

oh, spinning,

Scene	Duration	Panel	Duration
9	05:03	11	00:06



Dialogue

ANNIE

oh, spinning,

Scene	Duration	Panel	Duration
9	05:03	12	00:06



Dialogue

ANNIE

oh, spinning,

Scene	Duration	Panel	Duration
9	05:03	13	00:06



Dialogue

ANNIE

oh, spinning,

Scene	Duration	Panel	Duration
9	05:03	14	00:04



Dialogue

ANNIE

okay, when can I talk to you?

Scene	Duration	Panel	Duration
9	05:03	15	00:06



Dialogue

ANNIE

okay, when can I talk to you?

Scene	Duration	Panel	Duration
9	05:03	16	00:06



Dialogue

ANNIE

okay, when can I talk to you?

Scene	Duration	Panel	Duration
9	05:03	17	00:07



Dialogue

ANNIE

okay, when can I talk to you?

Scene	Duration	Panel	Duration
9	05:03	18	00:06

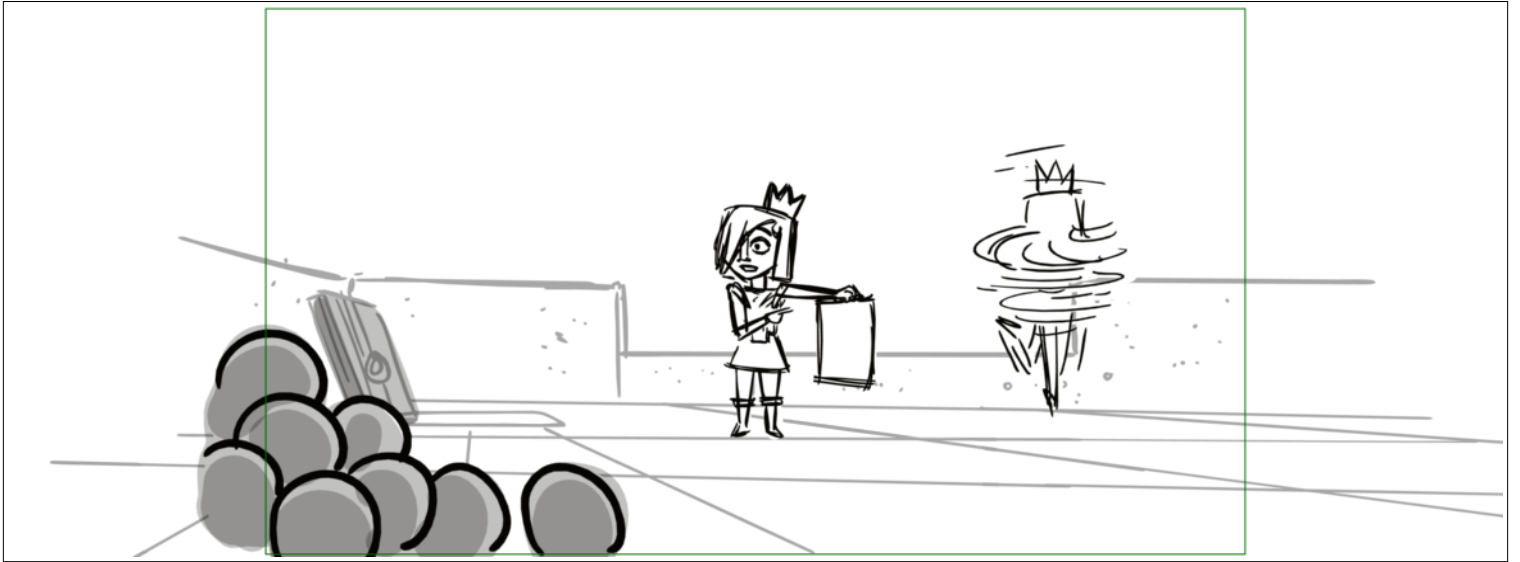

Dialogue

ANNIE

okay, when can I talk to you?

Scene	Duration	Panel	Duration
9	05:03	19	00:06



Dialogue

ANNIE

okay, when can I talk to you?

Scene	Duration	Panel	Duration
9	05:03	20	00:06



Dialogue

ANNIE

okay, when can I talk to you?

Scene	Duration	Panel	Duration
9	05:03	21	00:06



Dialogue

ANNIE

okay, when can I talk to you?

Scene	Duration	Panel	Duration
10	07:12	1	00:10

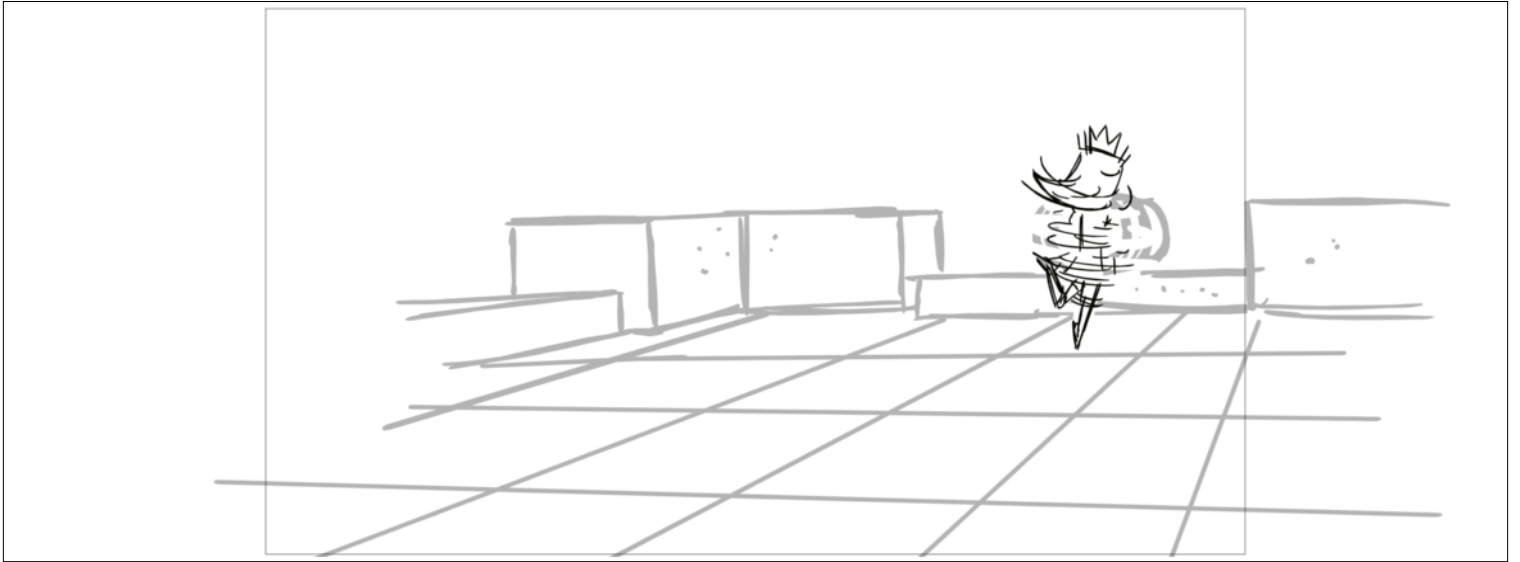

Action Notes

19A Annie stops him. She unrolls a battle plan schematic as Chloe continues spinning around the room, occasionally BANGING into things.

Dialogue

ANNIE (CONT'D)

20 (RE: PLAN) I've been thinking that an Elite Barb/Hog Rider attack would--

Scene	Duration	Panel	Duration
10	07:12	2	00:10

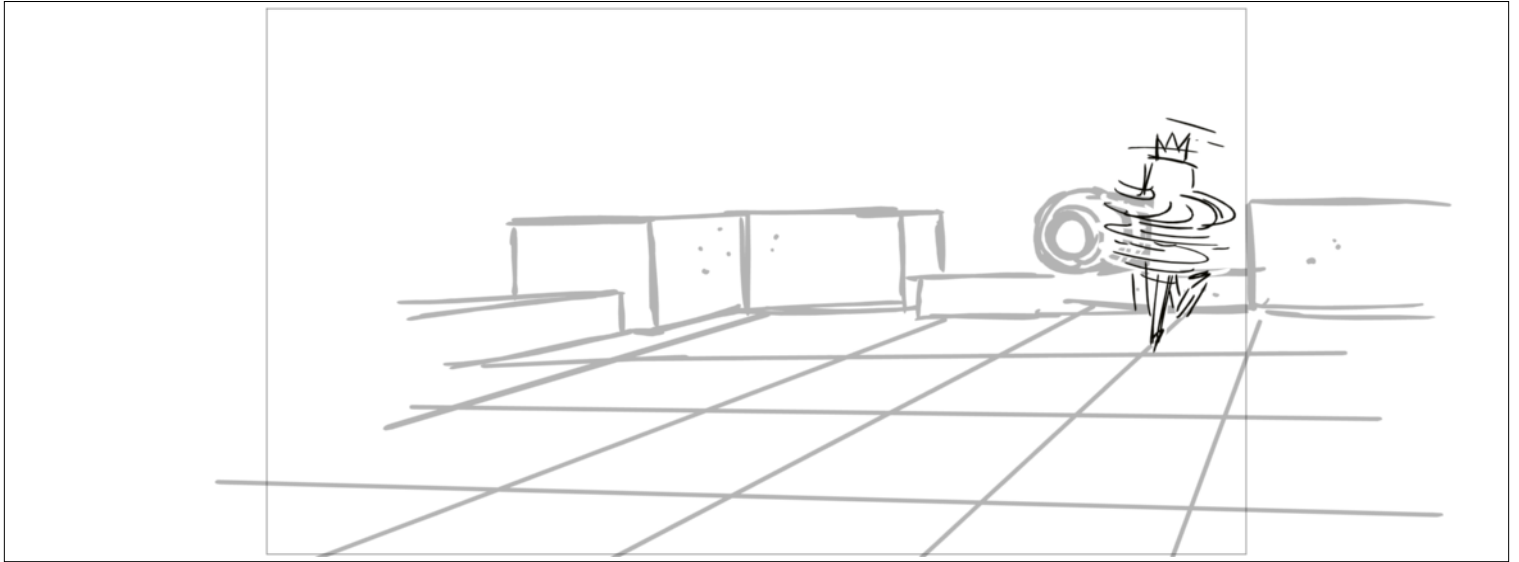

Action Notes

19A Annie stops him. She unrolls a battle plan schematic as Chloe continues spinning around the room, occasionally BANGING into things.

Dialogue

ANNIE (CONT'D)

20 (RE: PLAN) I've been thinking that an Elite Barb/Hog Rider attack would--

Scene	Duration	Panel	Duration
10	07:12	3	00:10

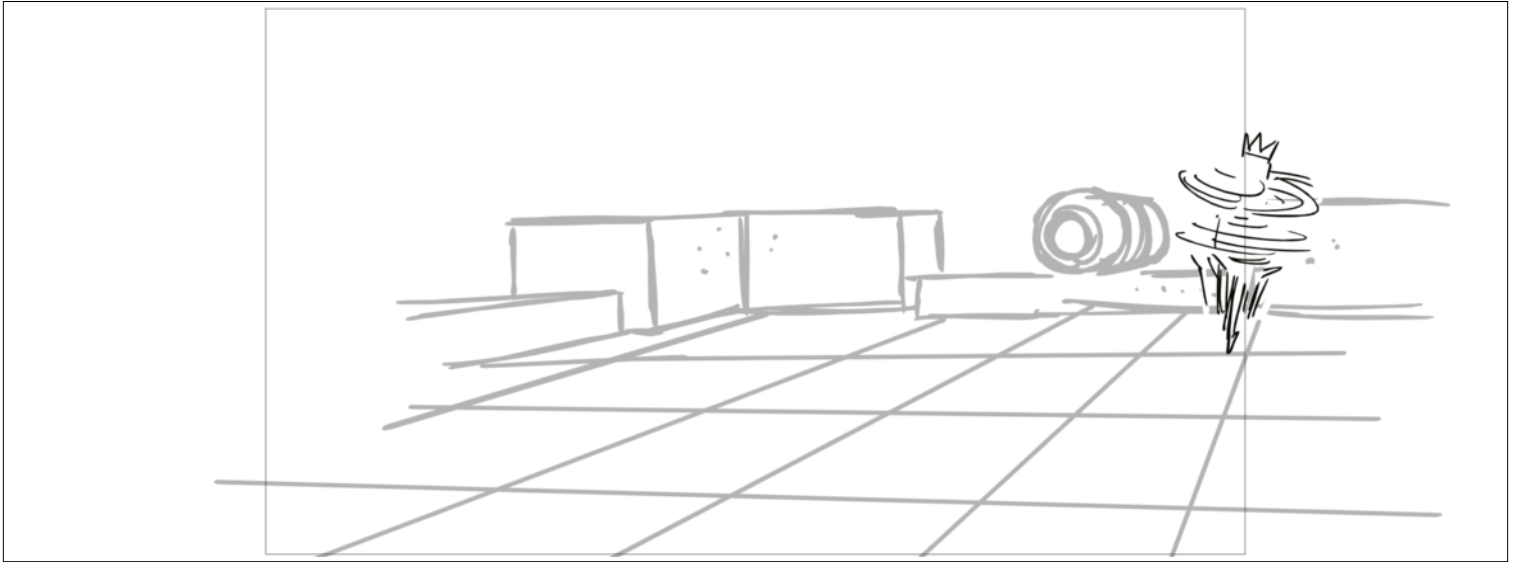

Action Notes

19A Annie stops him. She unrolls a battle plan schematic as Chloe continues spinning around the room, occasionally BANGING into things.

Dialogue

ANNIE (CONT'D)

20 (RE: PLAN) I've been thinking that an Elite Barb/Hog Rider attack would--

Scene	Duration	Panel	Duration
10	07:12	4	00:10

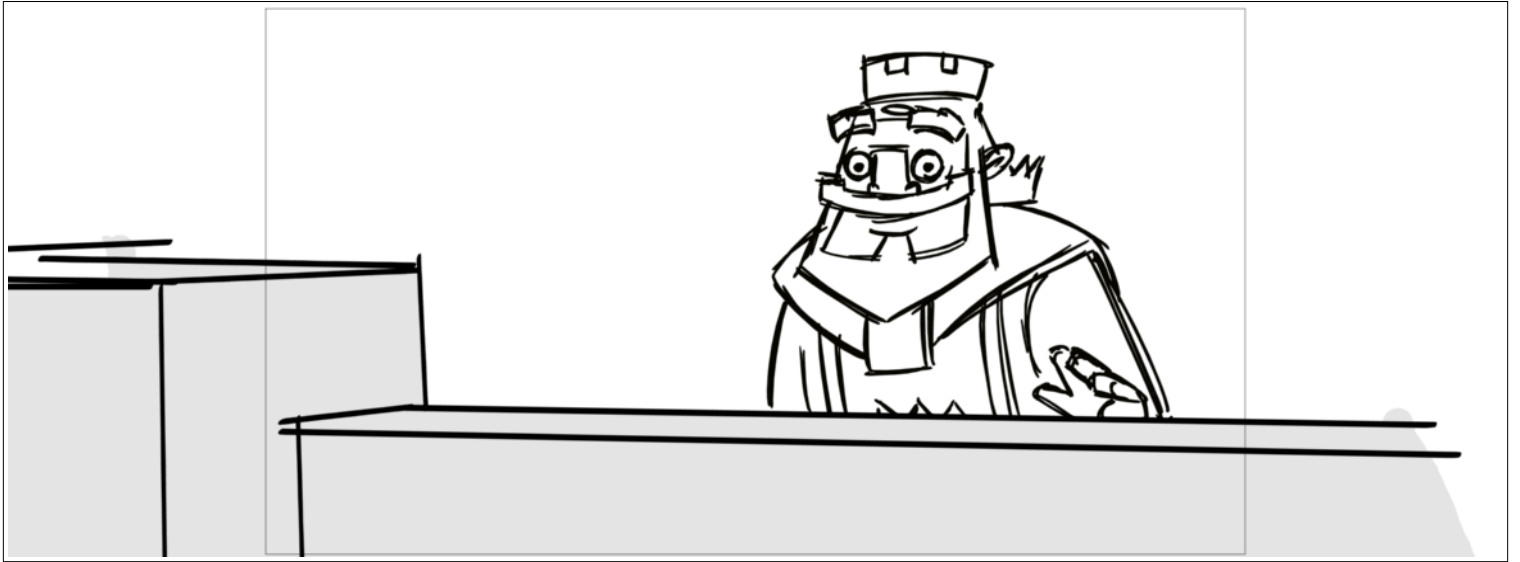

Action Notes

19A Annie stops him. She unrolls a battle plan schematic as Chloe continues spinning around the room, occasionally BANGING into things.

Dialogue

ANNIE (CONT'D)

20 (RE: PLAN) I've been thinking that an Elite Barb/Hog Rider attack would--

Scene	Duration	Panel	Duration
10	07:12	5	00:10



Action Notes

19A Annie stops him. She unrolls a battle plan schematic as Chloe continues spinning around the room, occasionally BANGING into things.

Dialogue

ANNIE (CONT'D)

20 (RE: PLAN) I've been thinking that an Elite Barb/Hog Rider attack would--

Scene	Duration	Panel	Duration
10	07:12	6	00:04



Action Notes

19A Annie stops him. She unrolls a battle plan schematic as Chloe continues spinning around the room, occasionally BANGING into things.

Dialogue

ANNIE (CONT'D)

20 (RE: PLAN) I've been thinking that an Elite Barb/Hog Rider attack would--

Scene	Duration	Panel	Duration
10	07:12	7	00:02



Action Notes

19A Annie stops him. She unrolls a battle plan schematic as Chloe continues spinning around the room, occasionally BANGING into things.

Dialogue

ANNIE (CONT'D)

20 (RE: PLAN) I've been thinking that an Elite Barb/Hog Rider attack would--

Scene	Duration	Panel	Duration
10	07:12	8	01:19



Action Notes

19A Annie stops him. She unrolls a battle plan schematic as Chloe continues spinning around the room, occasionally BANGING into things.

Dialogue

ANNIE (CONT'D)

20 (RE: PLAN) I've been thinking that an Elite Barb/Hog Rider attack would--

Scene	Duration	Panel	Duration
10	07:12	9	00:06



Action Notes

19A Annie stops him. She unrolls a battle plan schematic as Chloe continues spinning around the room, occasionally BANGING into things.

Dialogue

ANNIE (CONT'D)

20 (RE: PLAN) I've been thinking that an Elite Barb/Hog Rider attack would--

Scene	Duration	Panel	Duration
10	07:12	10	00:19

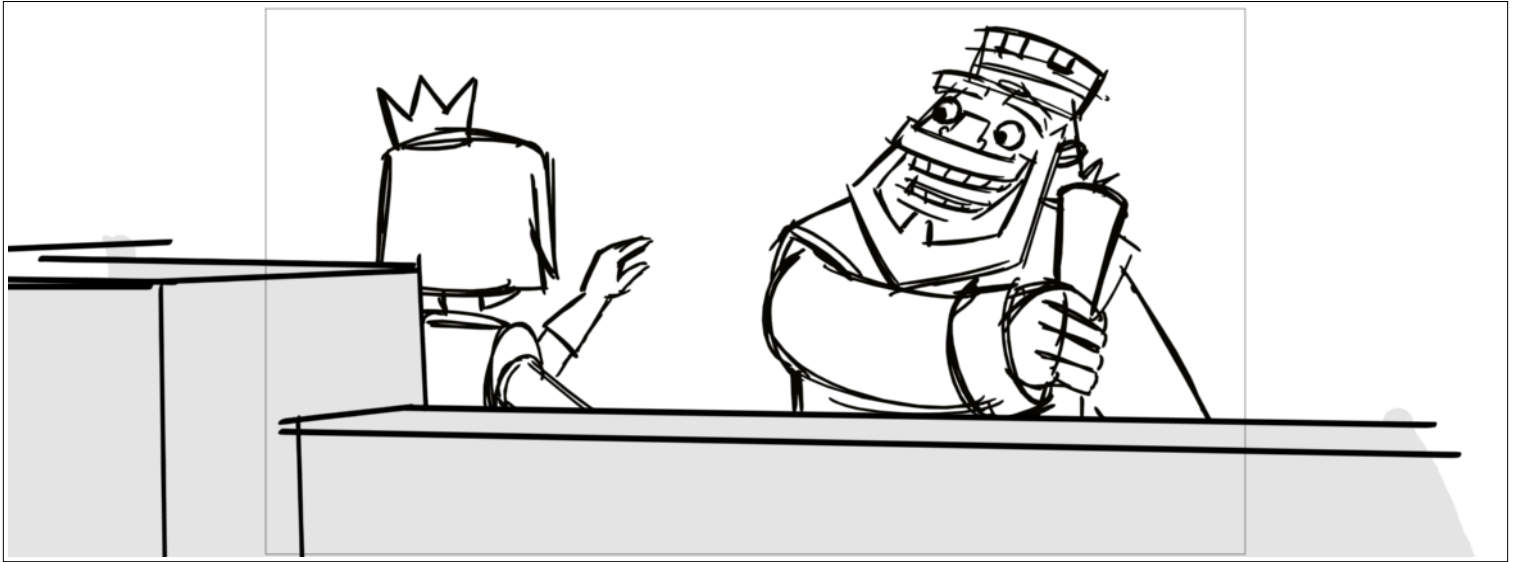

Dialogue

RED KING

**21 (ROLLS UP HER PLAN) Annie, let's stick to my plan, 'kay? Because...

Scene	Duration	Panel	Duration
10	07:12	11	01:18



Dialogue

RED KING

**21 (ROLLS UP HER PLAN) Annie, let's stick to my plan, 'kay? Because...

Scene	Duration	Panel	Duration
10	07:12	12	00:14

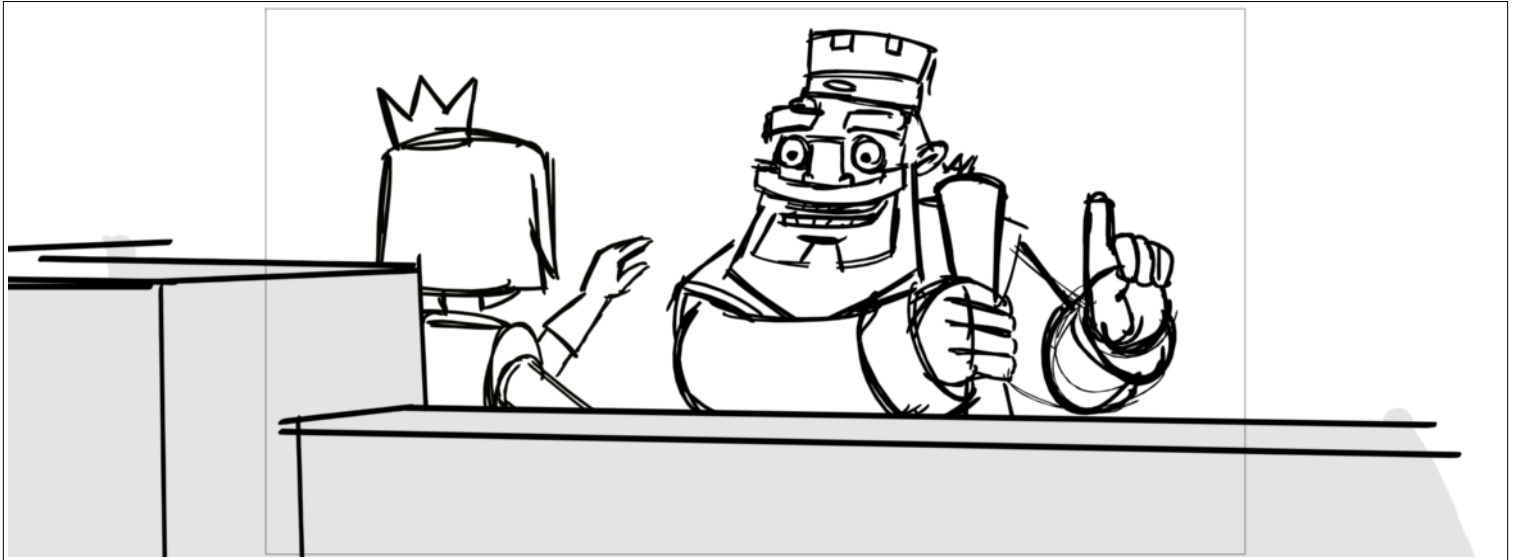

Dialogue

RED KING

**21 (ROLLS UP HER PLAN) Annie, let's stick to my plan, 'kay? Because...

Scene	Duration	Panel	Duration
12	08:16	1	00:14

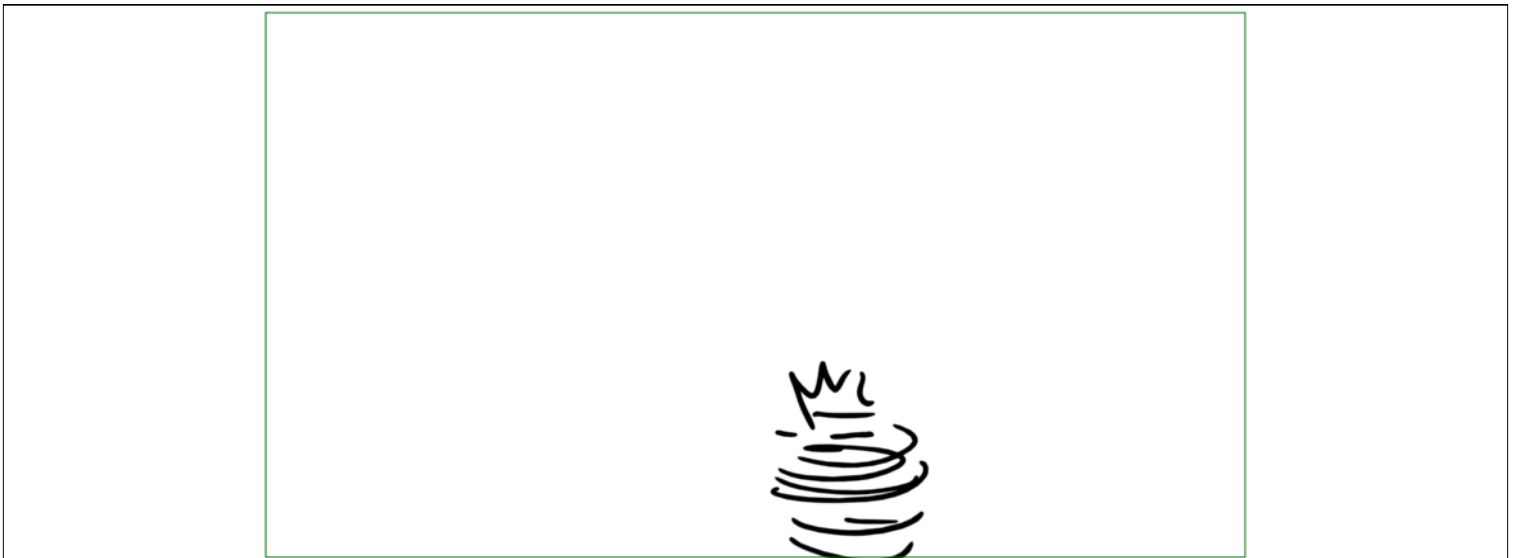

Scene	Duration	Panel	Duration
12	08:16	2	00:10

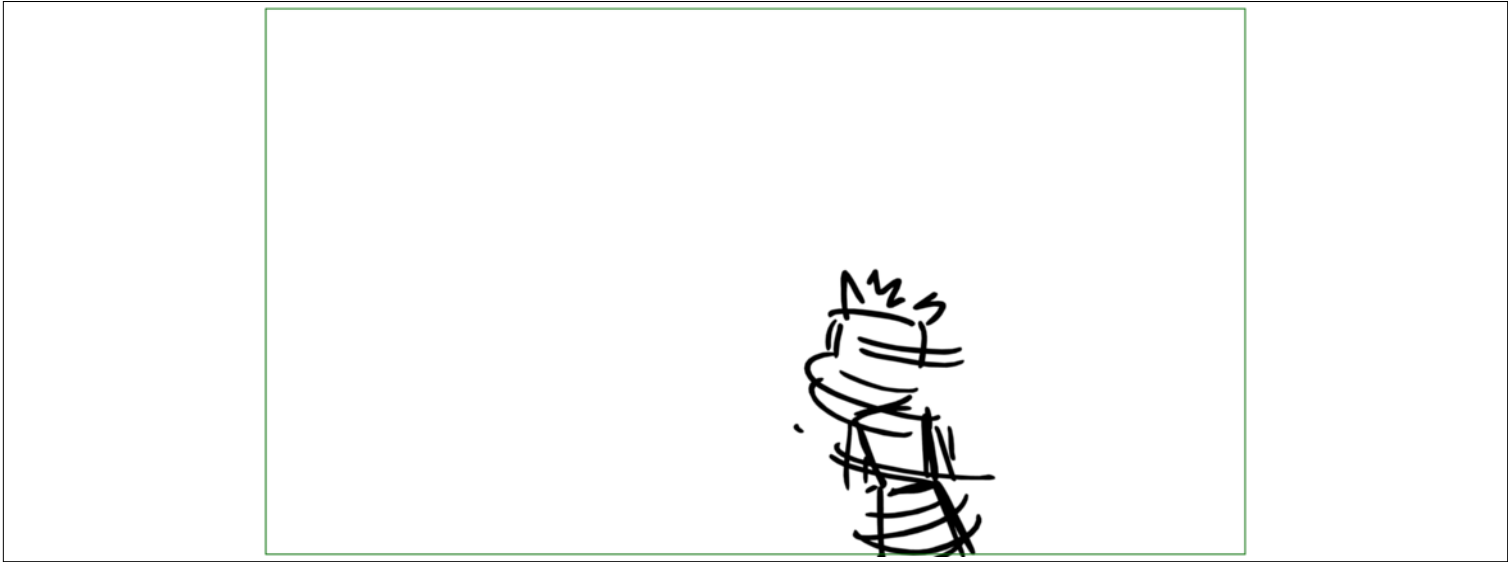

Scene	Duration	Panel	Duration
12	08:16	3	00:14



Scene	Duration	Panel	Duration
12	08:16	4	00:10

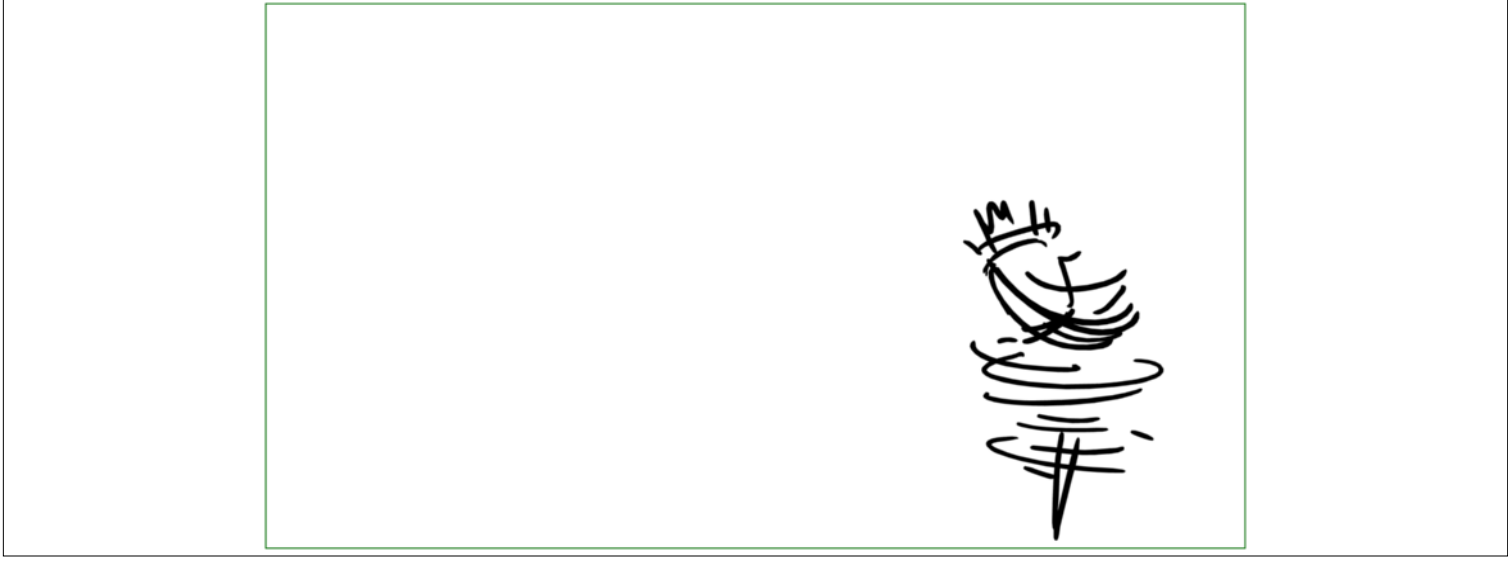

Scene	Duration	Panel	Duration
12	08:16	5	00:12



Scene	Duration	Panel	Duration
12	08:16	6	00:12



Scene	Duration	Panel	Duration
12	08:16	7	00:06

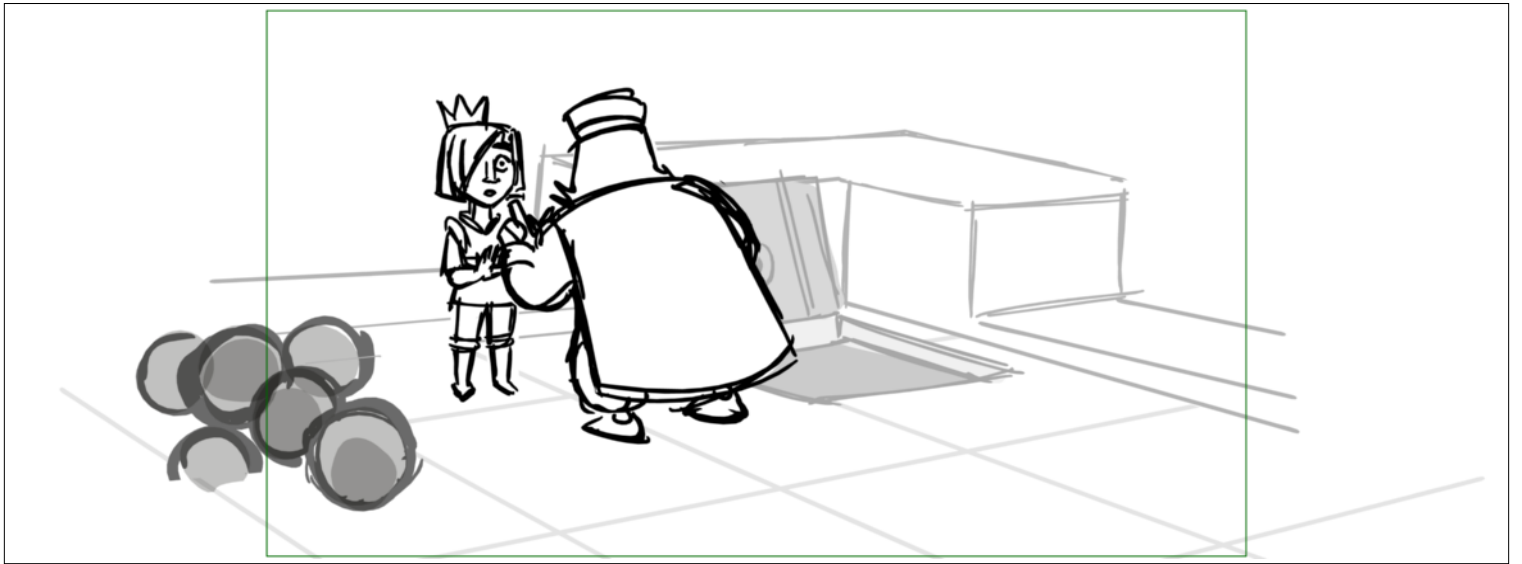

Dialogue

RED KING

(SINGING) IT'S A TOURNAMENT!

Scene	Duration	Panel	Duration
12	08:16	8	00:09



Dialogue

RED KING

(SINGING) IT'S A TOURNAMENT!

Scene	Duration	Panel	Duration
12	08:16	9	00:06



Dialogue

RED KING

(SINGING) IT'S A TOURNAMENT!

Scene	Duration	Panel	Duration
12	08:16	10	01:07



Dialogue

ANNIE

**24 FATHER, NO BOTHER BUT I GOTTA DISSENT.

Scene	Duration	Panel	Duration
12	08:16	11	00:04



Dialogue

ANNIE

**24 FATHER, NO BOTHER BUT I GOTTA DISSENT.

Scene	Duration	Panel	Duration
12	08:16	12	00:13



Dialogue

ANNIE

**24 FATHER, NO BOTHER BUT I GOTTA DISSENT.

Scene	Duration	Panel	Duration
12	08:16	13	00:12



Dialogue

ANNIE

**24 FATHER, NO BOTHER BUT I GOTTA DISSENT.

Scene	Duration	Panel	Duration
12	08:16	14	00:14



Dialogue

ANNIE

**24 FATHER, NO BOTHER BUT I GOTTA DISSENT.

Scene	Duration	Panel	Duration
12	08:16	15	00:16



Dialogue

ANNIE

I'VE BEEN DOWN SINCE DAY ONE FOR THIS TOURNAMENT.

Scene	Duration	Panel	Duration
12	08:16	16	01:01



Dialogue

ANNIE

I'VE BEEN DOWN SINCE DAY ONE FOR THIS TOURNAMENT.

Scene	Duration	Panel	Duration
13	08:22	1	00:04



Dialogue

ANNIE

I DON'T WANT TO BE CONTRADICTIONARY

Notes

H/U START POSE ONLY

Scene	Duration	Panel	Duration
13	08:22	2	00:04



Dialogue

ANNIE

I DON'T WANT TO BE CONTRADICTORY

Notes

H/U START POSE ONLY

Scene	Duration	Panel	Duration
13	08:22	3	00:04



Dialogue

ANNIE

I DON'T WANT TO BE CONTRADICTORY

Scene	Duration	Panel	Duration
13	08:22	4	00:05



Dialogue

ANNIE

I DON'T WANT TO BE CONTRADICTORY

Scene	Duration	Panel	Duration
13	08:22	5	00:05



Dialogue

ANNIE

I DON'T WANT TO BE CONTRADICTORY

Scene	Duration	Panel	Duration
13	08:22	6	00:05



Dialogue

ANNIE

I DON'T WANT TO BE CONTRADICTORY

Scene	Duration	Panel	Duration
13	08:22	7	00:07

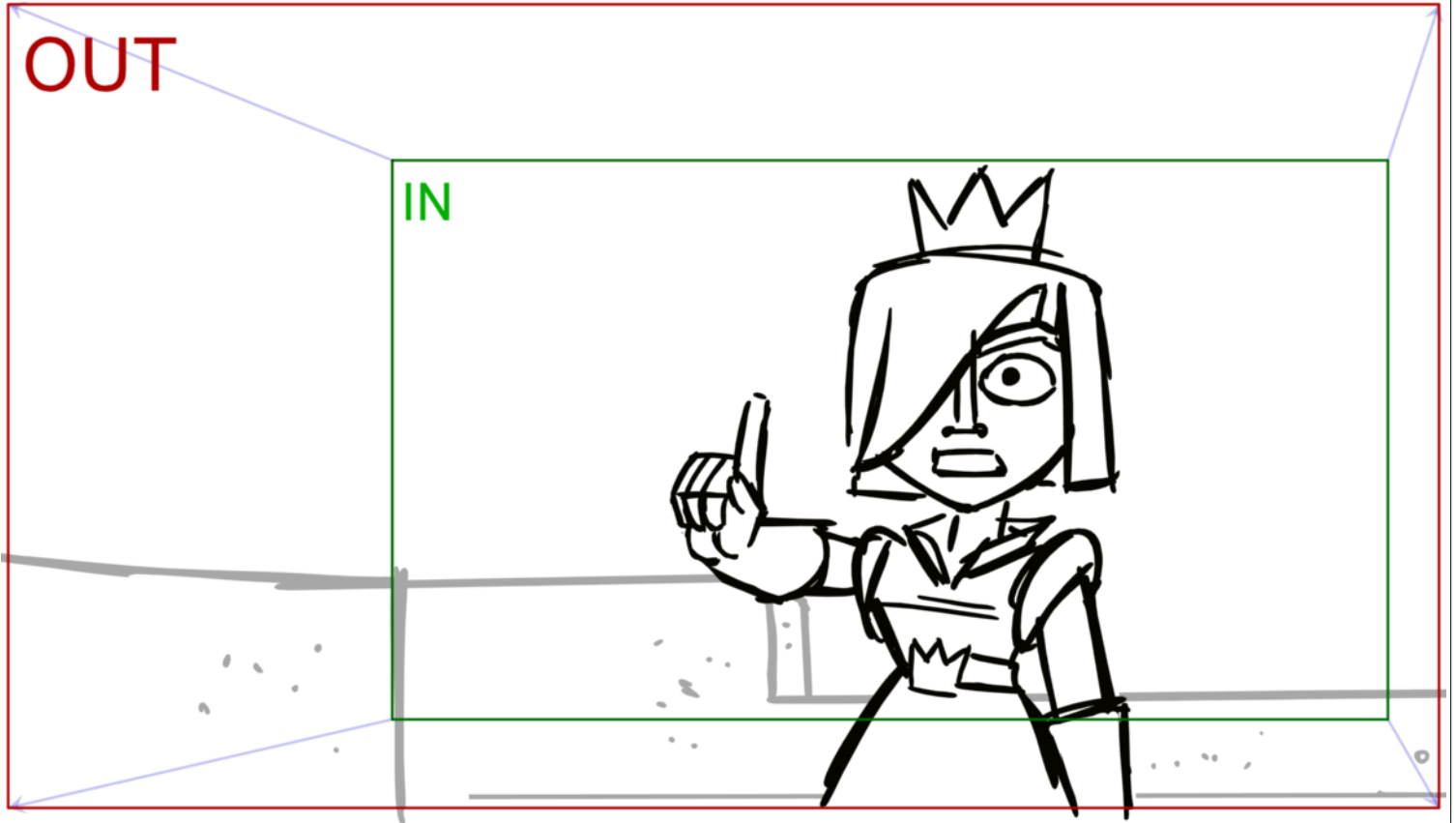

Dialogue

ANNIE

I DON'T WANT TO BE CONTRADICTORY

Scene	Duration	Panel	Duration
13	08:22	8	00:07



Dialogue

ANNIE

BUT I CAN HELP LEAD US TO VICTOR

Scene	Duration	Panel	Duration
13	08:22	9	00:18



Dialogue

ANNIE

BUT I CAN HELP LEAD US TO VICTOR

Scene	Duration	Panel	Duration
13	08:22	10	00:07



Dialogue

ANNIE

BUT I CAN HELP LEAD US TO VICTOR

Scene	Duration	Panel	Duration
13	08:22	11	00:09



Dialogue

ANNIE

BUT I CAN HELP LEAD US TO VICTOR

Scene	Duration	Panel	Duration
13	08:22	12	00:04



Dialogue

ANNIE

BUT I CAN HELP LEAD US TO VICTOR

Scene	Duration	Panel	Duration
13	08:22	13	00:06



Dialogue

ANNIE

BUT I CAN HELP LEAD US TO VICTOR

Scene	Duration	Panel	Duration
13	08:22	14	02:02



Dialogue

RED KING

25 YOU'RE NOT A STRATEGIST,

Scene	Duration	Panel	Duration
13	08:22	15	01:22



Dialogue

YOU'RE MY DAUGHTER,

Scene	Duration	Panel	Duration
13	08:22	16	00:23

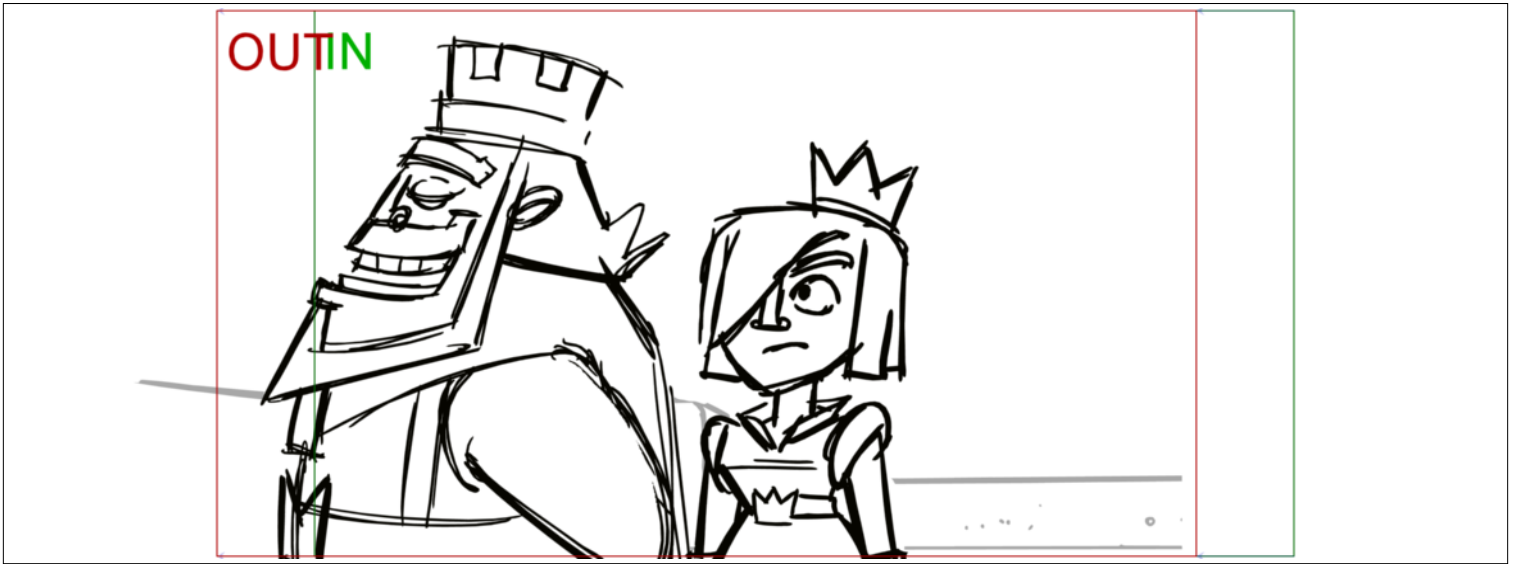

Dialogue

A FLOWER! /

Scene	Duration	Panel	Duration
13	08:22	17	00:10



Dialogue

A FLOWER! /

Scene	Duration	Panel	Duration
14	07:11	1	00:06



Dialogue

RED KING (CONT'D)

**26 TRUST ME ON THIS--

Scene	Duration	Panel	Duration
14	07:11	2	00:05



Dialogue

RED KING (CONT'D)

**26 TRUST ME ON THIS--

Scene	Duration	Panel	Duration
14	07:11	3	00:06



Dialogue

RED KING (CONT'D)

**26 TRUST ME ON THIS--

Scene	Duration	Panel	Duration
14	07:11	4	00:18



Dialogue

RED KING (CONT'D)

**26 TRUST ME ON THIS--

Scene	Duration	Panel	Duration
14	07:11	5	00:05



Dialogue

RED KING (CONT'D)

YOUR PLACE IS IN A

Scene	Duration	Panel	Duration
14	07:11	6	00:14



Dialogue

RED KING (CONT'D)

YOUR PLACE IS IN A

Scene	Duration	Panel	Duration
14	07:11	7	00:09



Dialogue

RED KING (CONT'D)

YOUR PLACE IS IN A

Scene	Duration	Panel	Duration
14	07:11	8	00:05



Dialogue

RED KING (CONT'D)

YOUR PLACE IS IN A

Scene	Duration	Panel	Duration
14	07:11	9	00:10



Dialogue

RED KING (CONT'D)

YOUR PLACE IS IN A

Scene	Duration	Panel	Duration
14	07:11	10	00:14

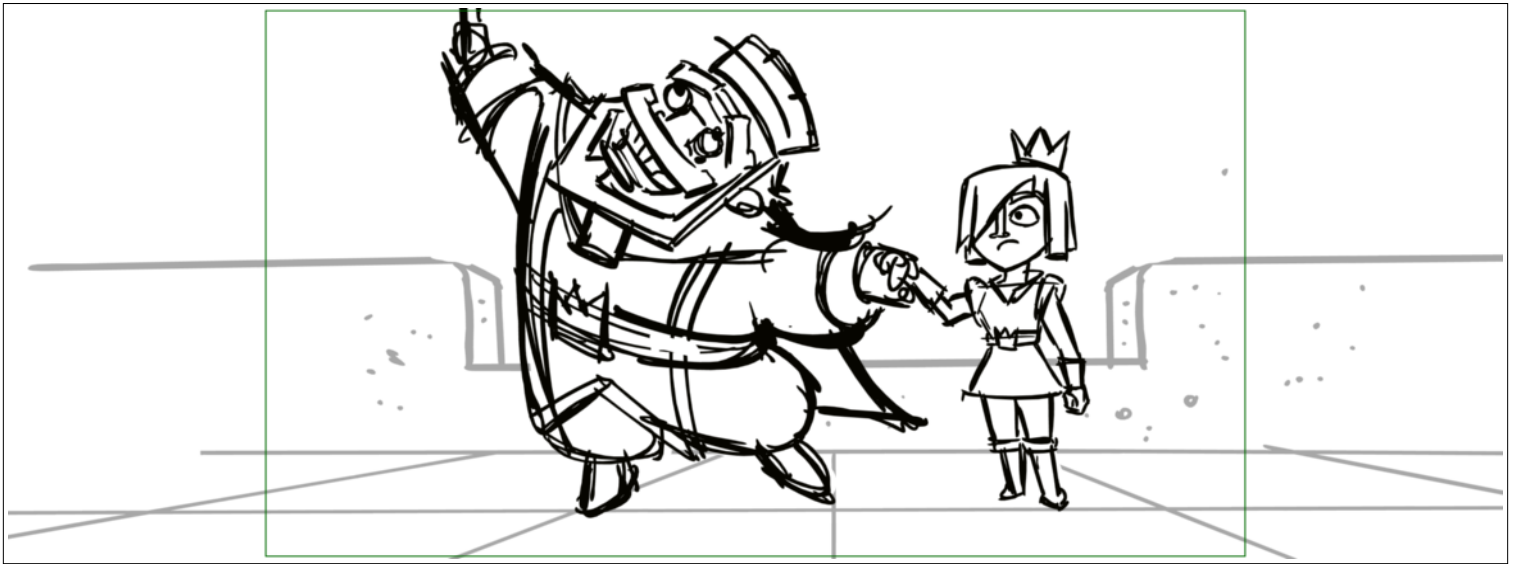

Dialogue

RED KING (CONT'D)

TOWER

Notes

a

Scene	Duration	Panel	Duration
14	07:11	11	00:09

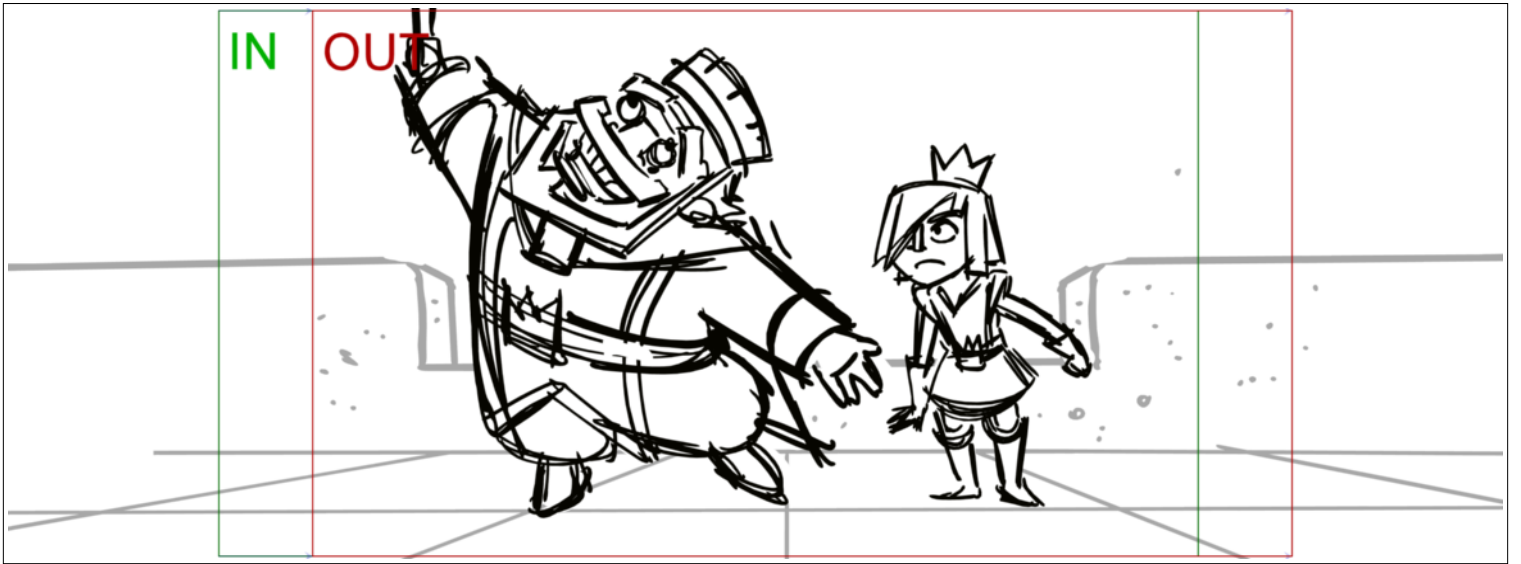

Dialogue
(cont.)

Scene	Duration	Panel	Duration
14	07:11	12	00:10

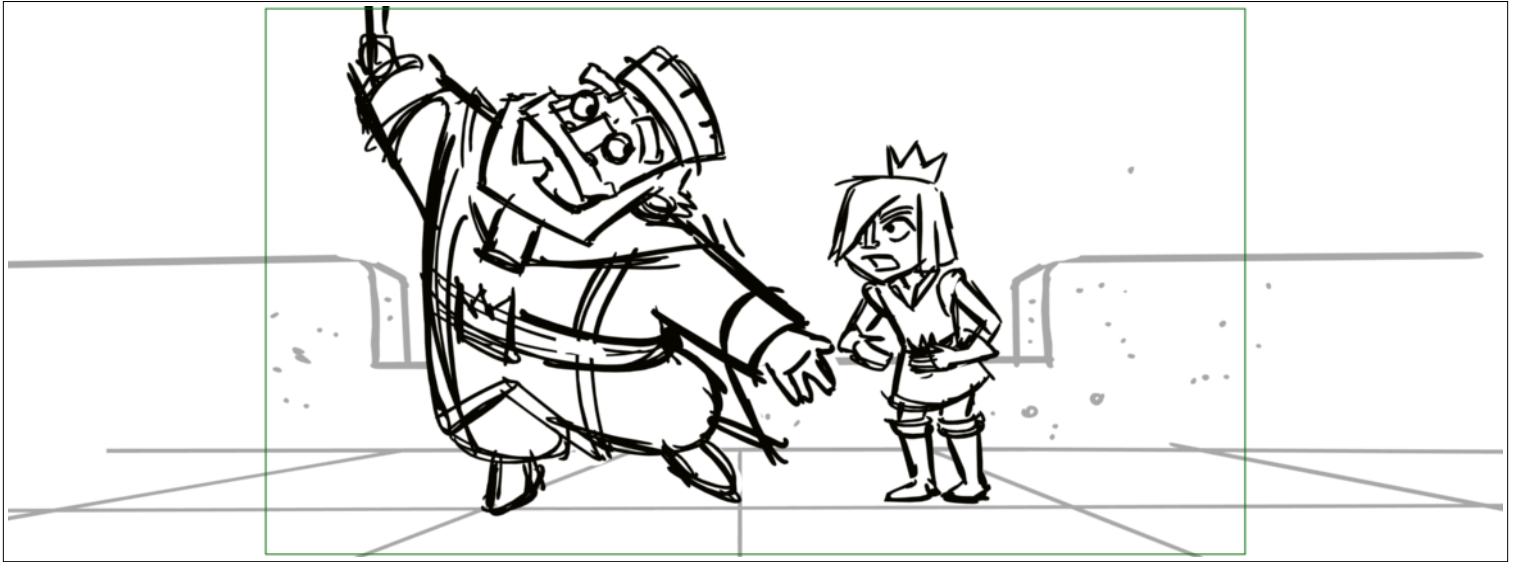

Dialogue

ANNIE

**29 DAD YOU GOTTA HEAR ME / MY ATTACK WILL CAN MAKE SOME HISTORY!

Scene	Duration	Panel	Duration
14	07:11	13	00:09

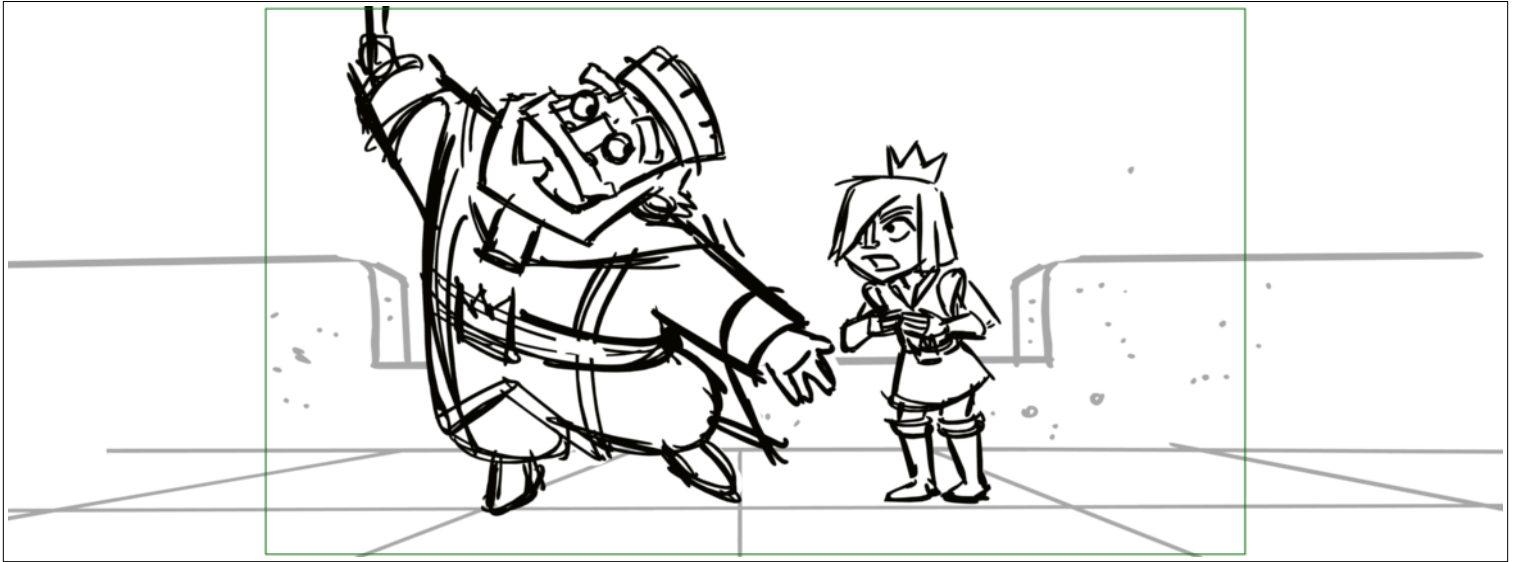

Dialogue

ANNIE

**29 DAD YOU GOTTA HEAR ME / MY ATTACK WILL CAN MAKE SOME HISTORY!

Scene	Duration	Panel	Duration
14	07:11	14	00:16



Dialogue

ANNIE

**29 DAD YOU GOTTA HEAR ME / MY ATTACK WILL CAN MAKE SOME HISTORY!

Scene	Duration	Panel	Duration
14	07:11	15	00:13



Dialogue

ANNIE

**29 DAD YOU GOTTA HEAR ME / MY ATTACK WILL CAN MAKE SOME HISTORY!

Scene	Duration	Panel	Duration
14	07:11	16	01:06



Dialogue

ANNIE

**29 DAD YOU GOTTA HEAR ME / MY ATTACK CAN MAKE SOME HISTORY!

Scene	Duration	Panel	Duration
15	07:13	1	00:04



Action Notes

Annie and the King face off. The song builds to a finish...

Dialogue

RED KING

30 LISTEN TO MY ORDERS,

Scene	Duration	Panel	Duration
15	07:13	2	00:06

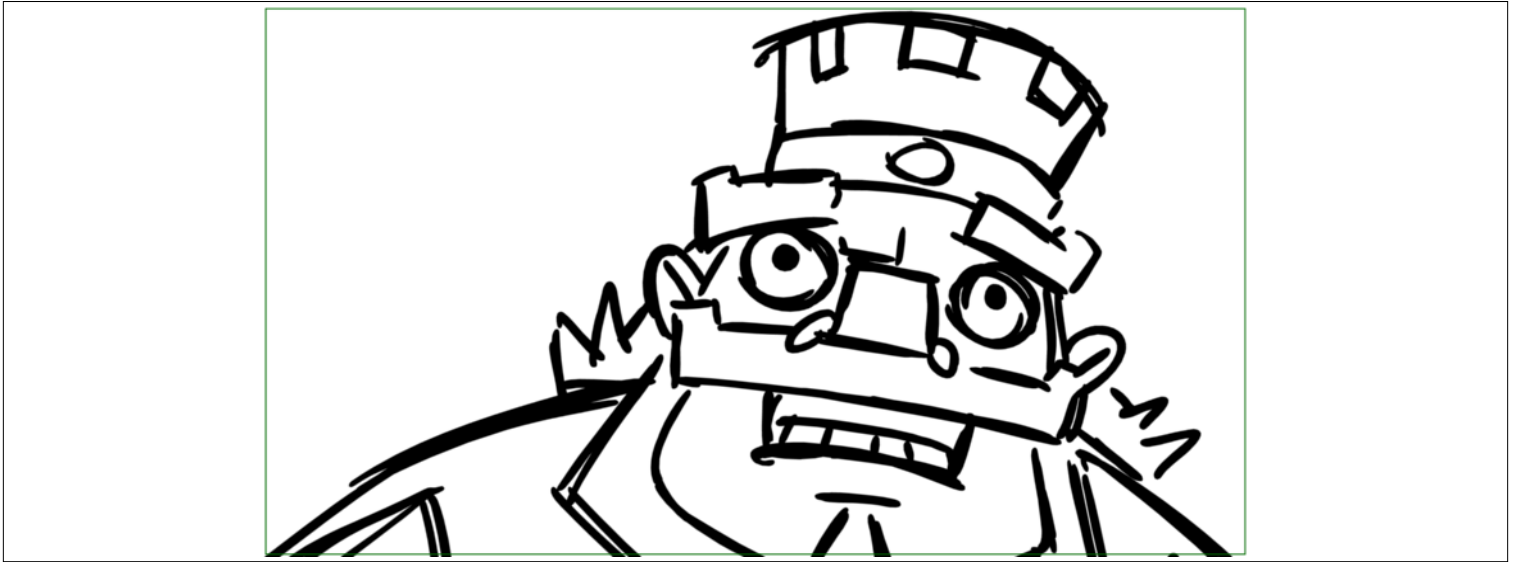

Action Notes

Annie and the King face off. The song builds to a finish...

Dialogue

(cont)

Scene	Duration	Panel	Duration
15	07:13	3	00:06



Action Notes

Annie and the King face off. The song builds to a finish...

Dialogue

(cont)

Scene	Duration	Panel	Duration
15	07:13	4	00:06

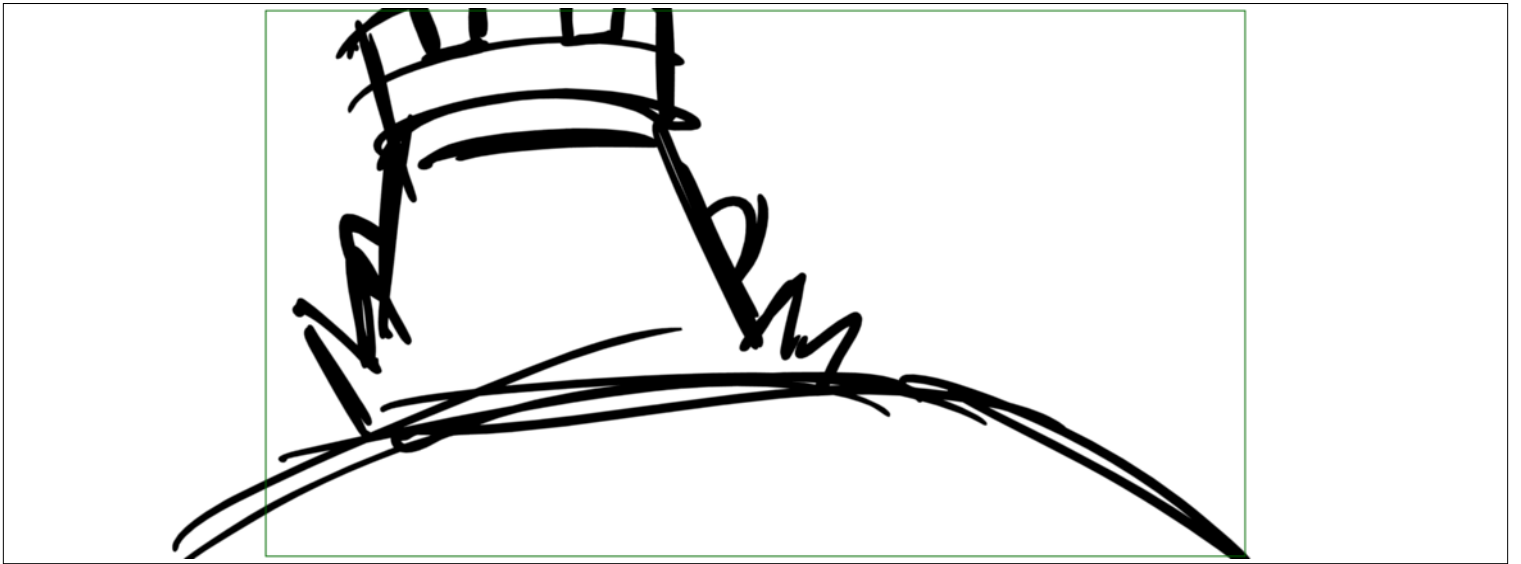

Action Notes

Annie and the King face off. The song builds to a finish...

Dialogue

(cont)

Scene	Duration	Panel	Duration
15	07:13	5	00:15



Action Notes

Annie and the King face off. The song builds to a finish...

Dialogue

(cont)

Scene	Duration	Panel	Duration
15	07:13	6	01:02



Action Notes

Annie and the King face off. The song builds to a finish...

Dialogue

AND I'LL GUARANTEE YOU...

Scene	Duration	Panel	Duration
15	07:13	7	00:10



Action Notes

Annie and the King face off. The song builds to a finish...

Dialogue

RED KING

YOU (cont)

ANNIE

31 BUT, DAD, I SWEAR, MY PLAN IS THE KEY TO...

Scene	Duration	Panel	Duration
15	07:13	8	00:21



Scene	Duration	Panel	Duration
15	07:13	9	00:12

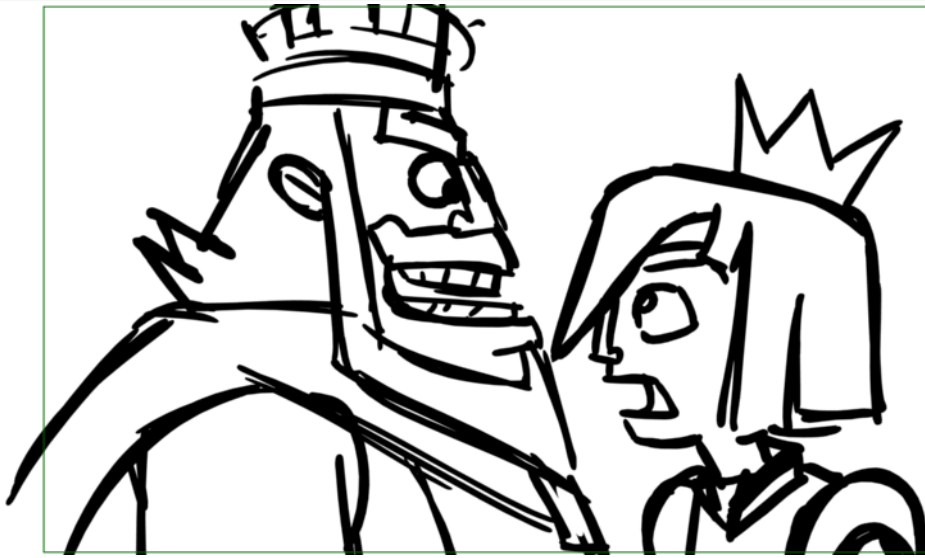

Dialogue

ANNIE

31 BUT, DAD, I SWEAR, MY PLAN IS THE KEY TO...

Scene	Duration	Panel	Duration
15	07:13	10	00:12



Dialogue

RED KING/ANNIE

**32 VICTORY!

Scene	Duration	Panel	Duration
15	07:13	11	00:09



Dialogue

RED KING/ANNIE

**32 VICTORY!

Scene	Duration	Panel	Duration
15	07:13	12	01:06



Dialogue

RED KING/ANNIE

**32 VICTORY!

Scene	Duration	Panel	Duration
15	07:13	13	01:00



Dialogue

ANNIE

31 BUT, DAD, I SWEAR, MY PLAN IS THE KEY TO...

Scene	Duration	Panel	Duration
16	03:18	1	00:06

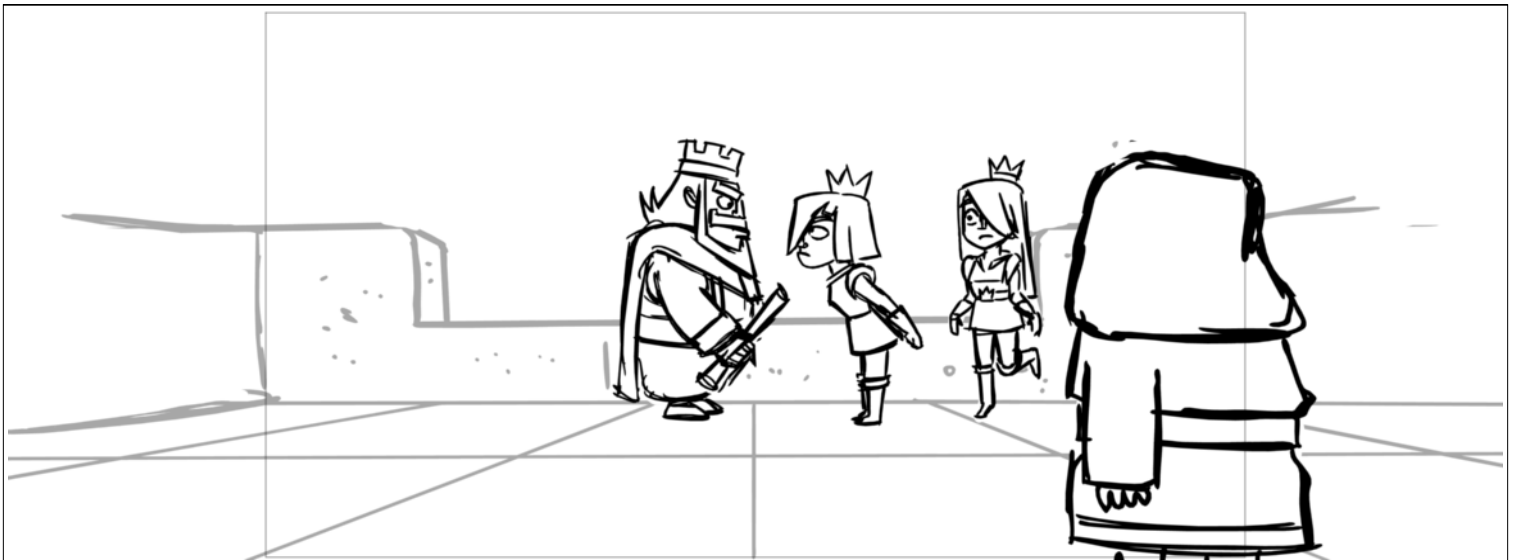

Scene	Duration	Panel	Duration
16	03:18	2	00:14

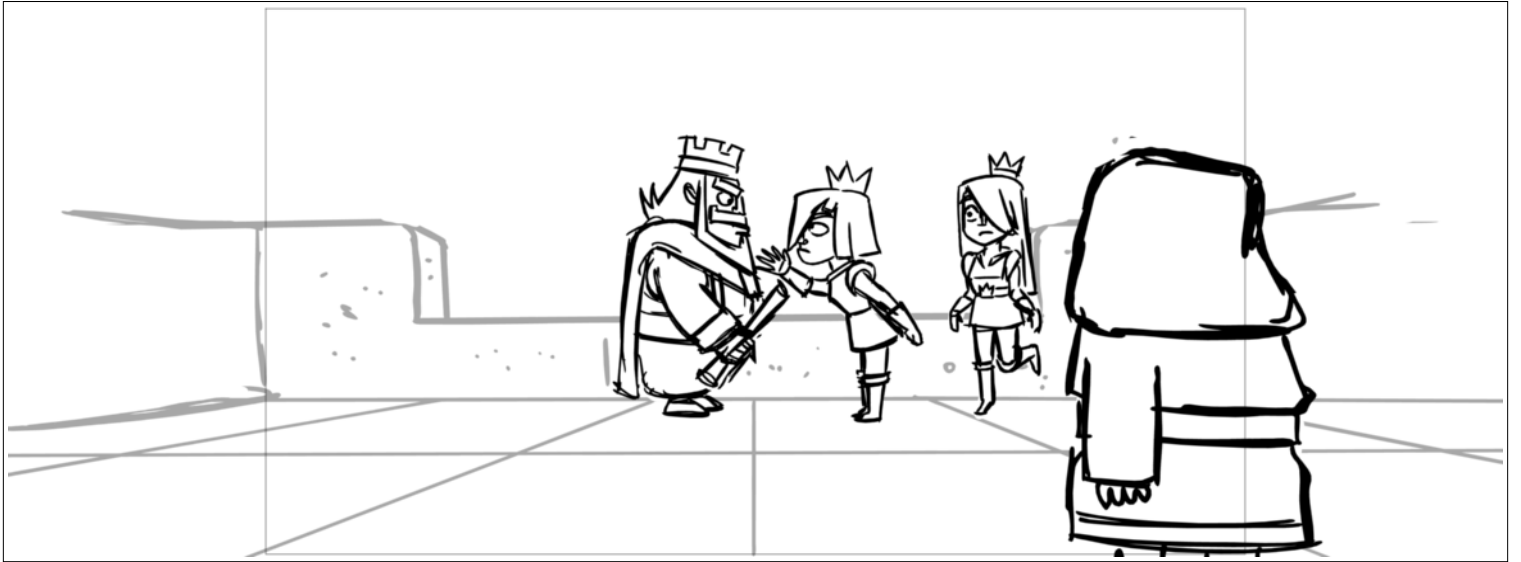

Scene	Duration	Panel	Duration
16	03:18	3	00:10

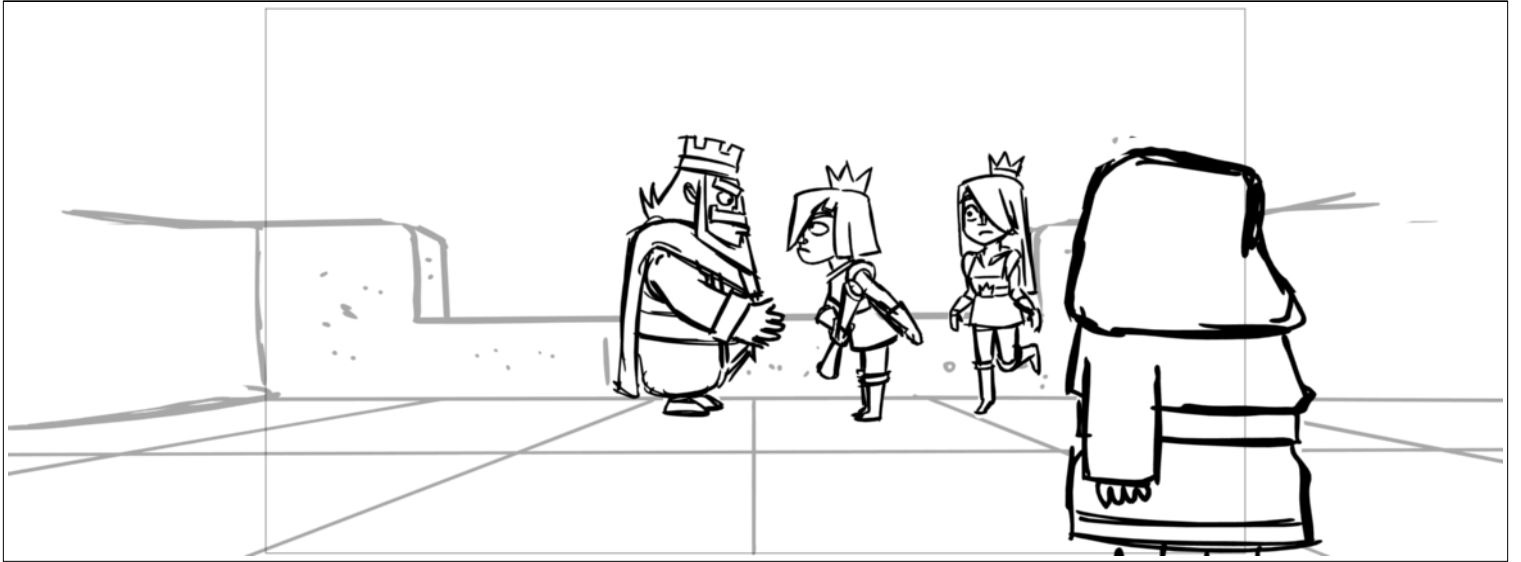

Scene	Duration	Panel	Duration
16	03:18	4	00:06

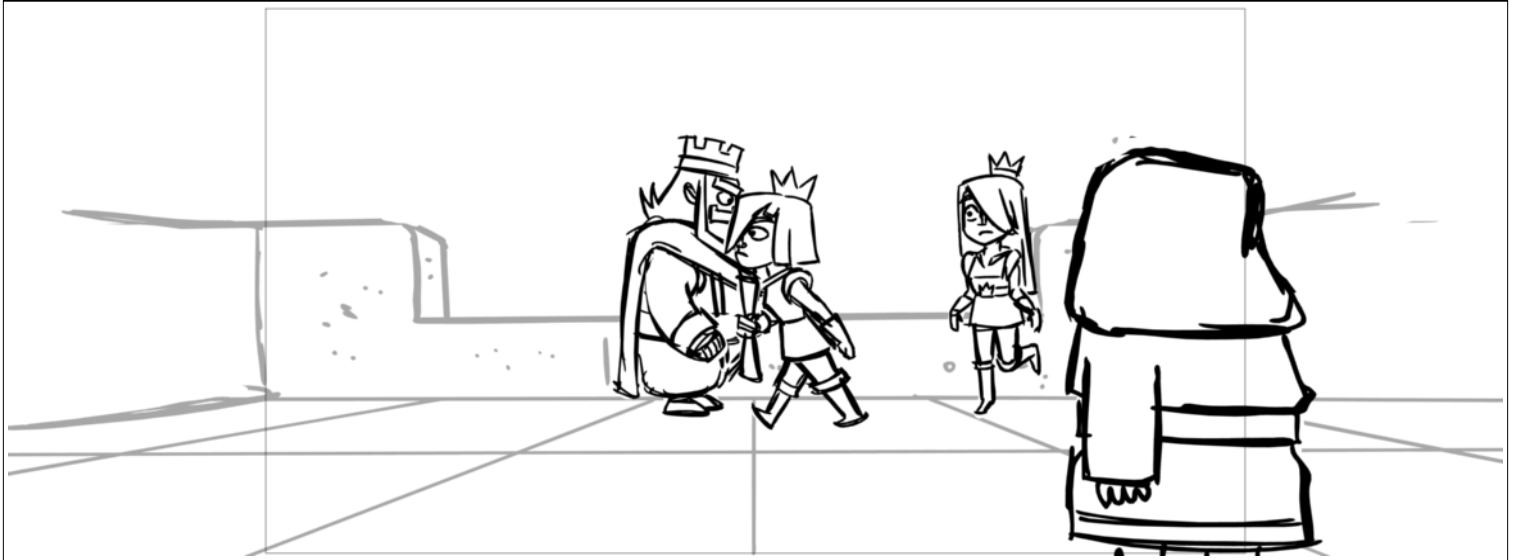

Scene	Duration	Panel	Duration
16	03:18	5	00:06

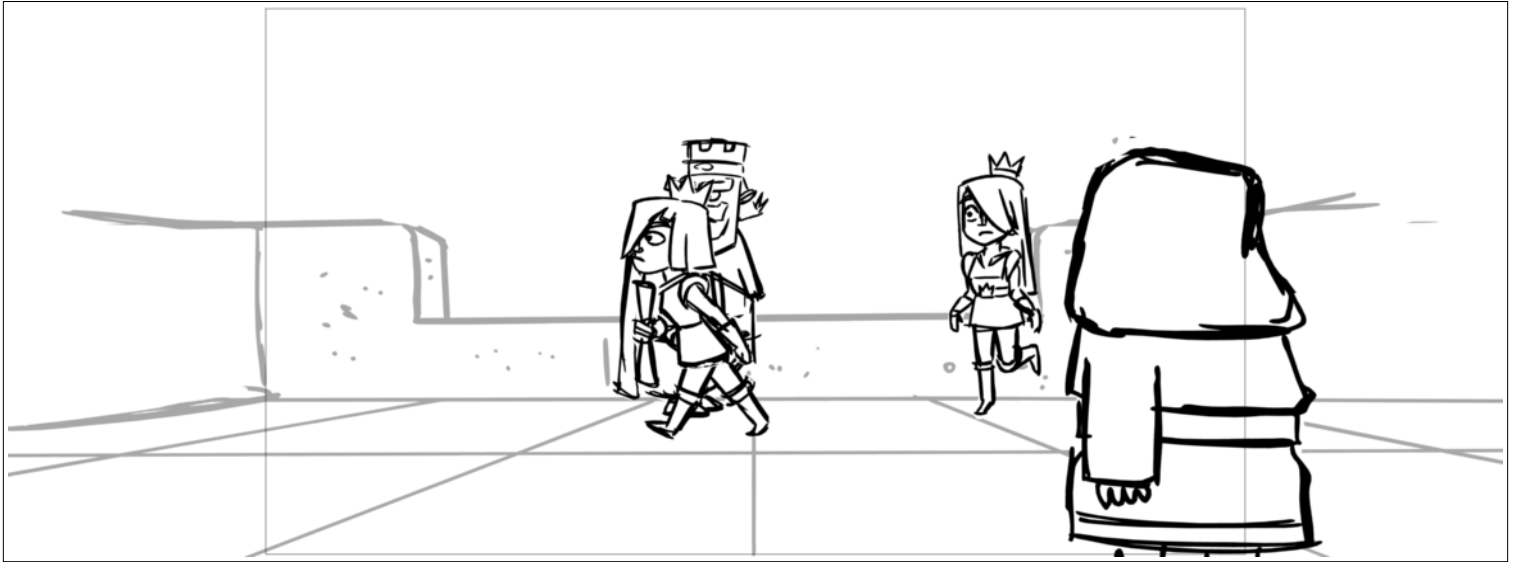

Scene	Duration	Panel	Duration
16	03:18	6	00:06

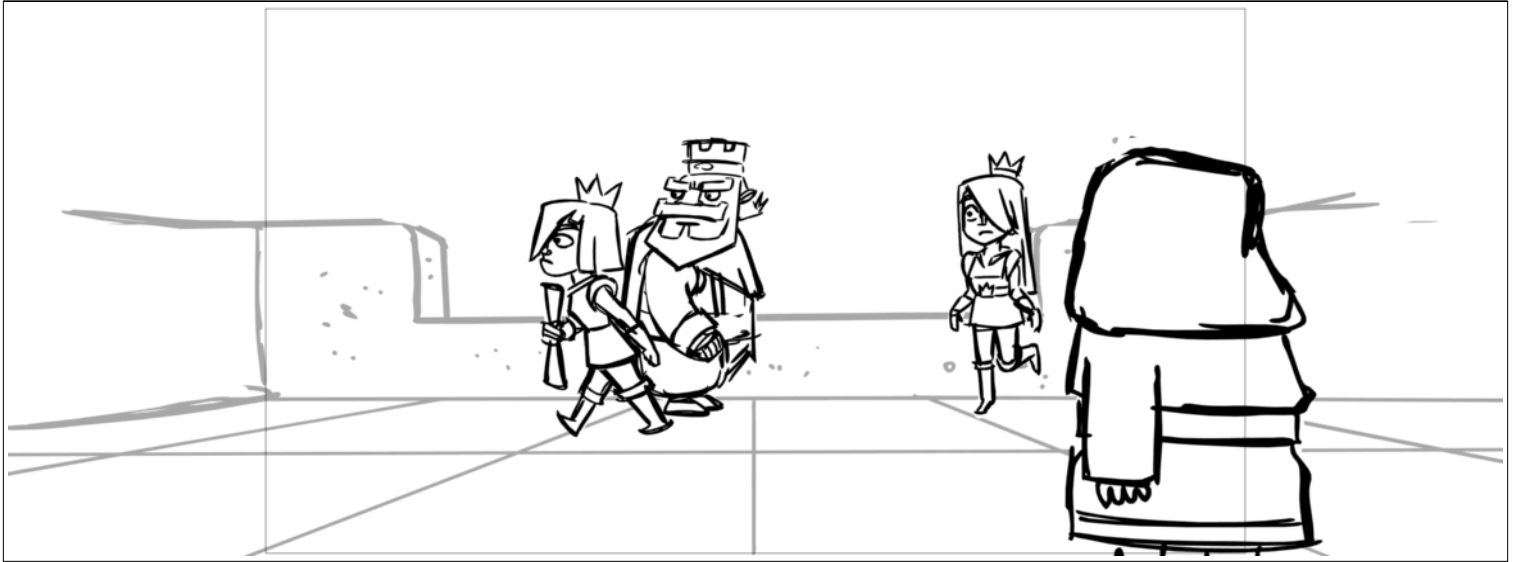

Scene	Duration	Panel	Duration
16	03:18	7	00:06

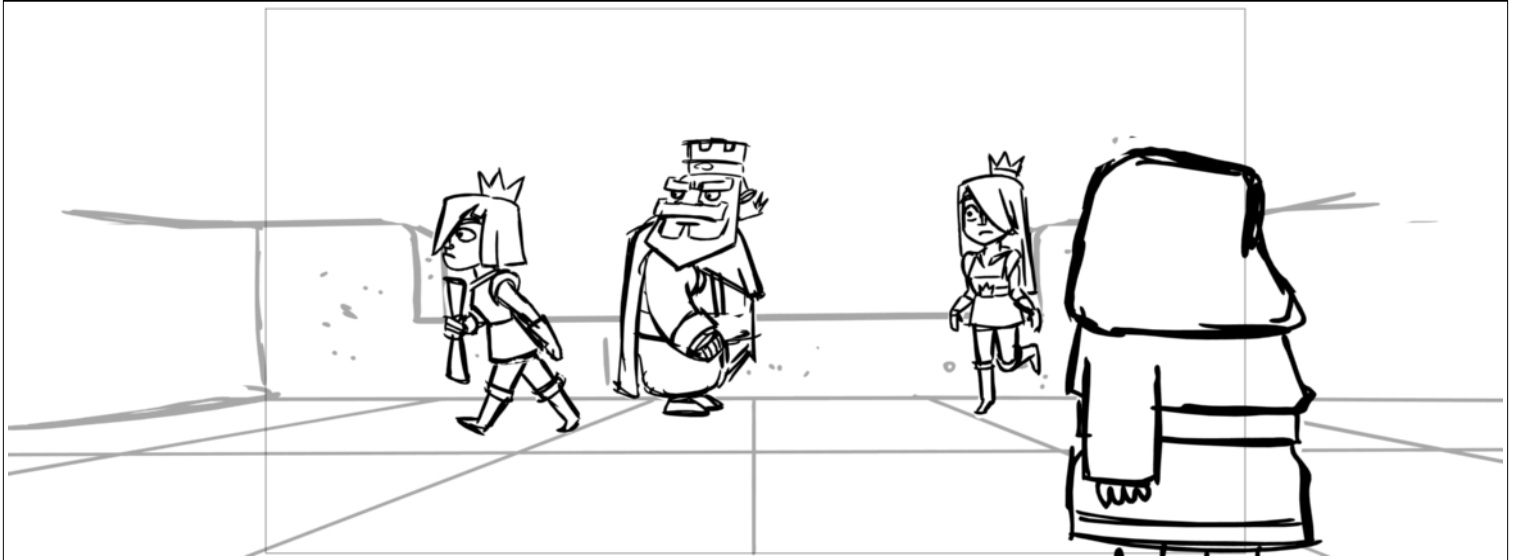

Scene	Duration	Panel	Duration
16	03:18	8	00:06

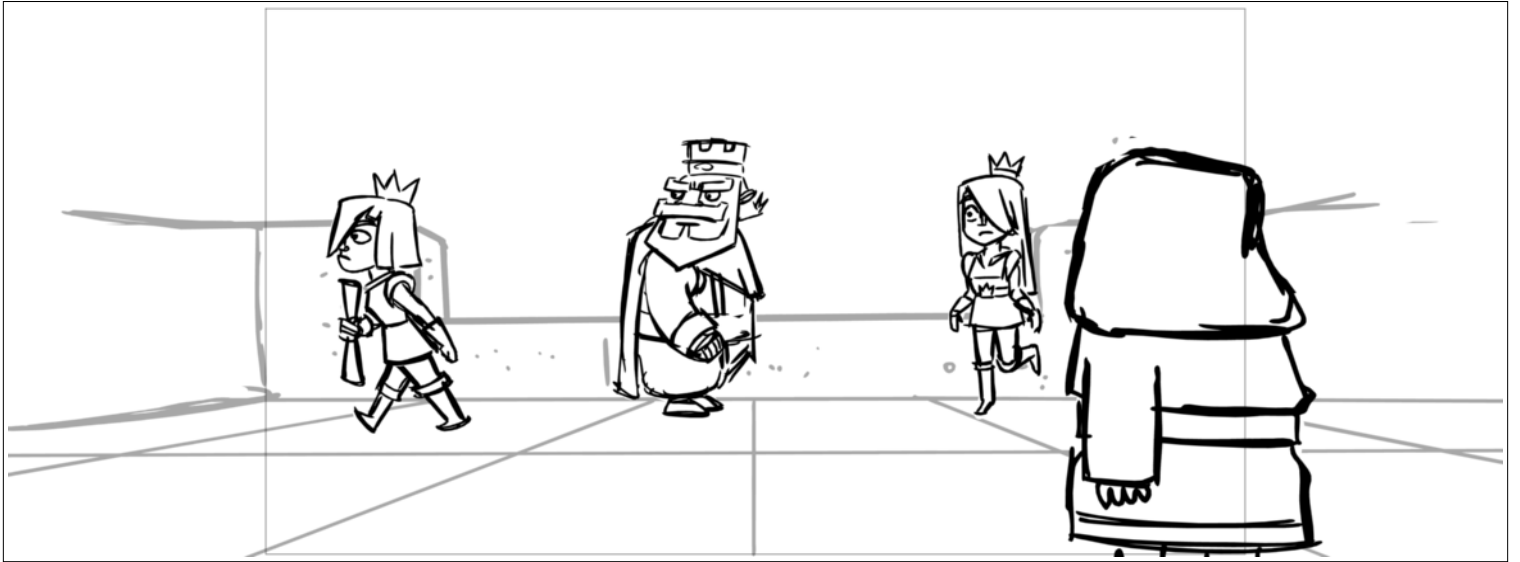

Scene	Duration	Panel	Duration
16	03:18	9	00:07

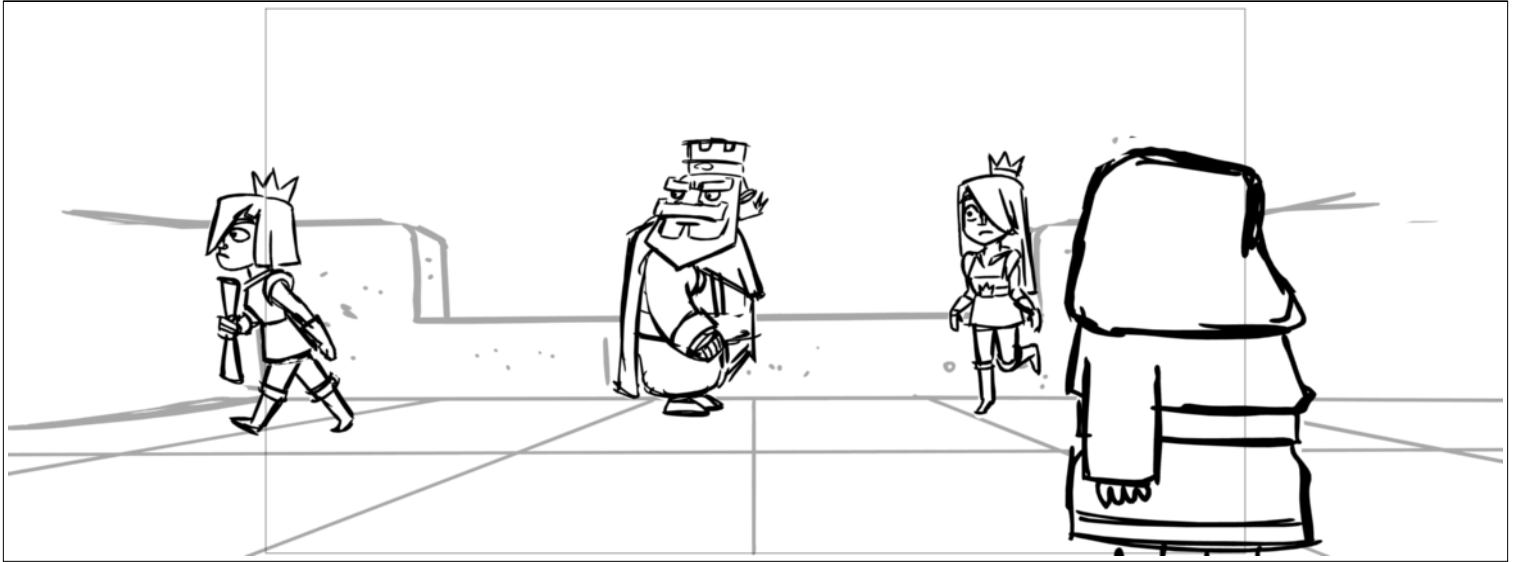

Scene	Duration	Panel	Duration
16	03:18	10	00:23

