

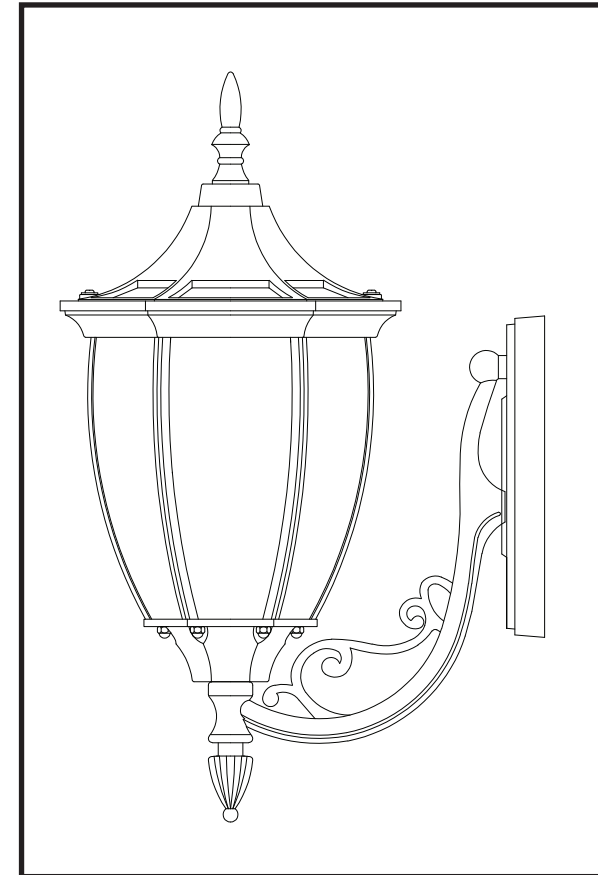

Crestmont Wall Mount Solar Lantern Instruction Manual



Model No. 302079

Read the instructions and precautions before use of this product

Please keep this instruction manual for future reference

For warranty information, please refer to the back page of this instruction manual.

Limited Warranty

J & J Global LLC. Products for Home Use

J & J Global LLC. (Seller) warrants to the original Buyer only, that this Sunray Product will be free from defects in material and workmanship for a period of one (1) year from date of purchase. SELLER'S SOLE OBLIGATION AND BUYER'S EXCLUSIVE REMEDY UNDER THIS LIMITED WARRANTY SHALL BE THE REPAIR OR REPLACEMENT OF PARTS, WITHOUT CHARGE, WHICH ARE DEFECTIVE IN MATERIAL OR WORKMANSHIP. ANY PARTS AS DETERMINED BY THE SELLER WHICH HAVE BEEN MISUSED; ABUSED OR DAMAGED EITHER DIRECTLY OR INDIRECTLY FROM REPAIRS OR ALTERATIONS ATTEMPTED BY UNAUTHORIZED PERSONS; IMPROPER MAINTENANCE, NEGLIGENCE OR ACCIDENT ARE NOT COVERED BY THIS LIMITED WARRANTY. This warranty does not apply to damage, heat-induced coloration changes, scratching or alteration due to normal use or weathering. To make a claim under this Limited Warranty, you must return the complete product with proof of purchase, transportation prepaid, to any World Factory, Inc. authorized service center. Call 1-888-422-7800 for the location of the nearest authorized service center.

Additional Limitations

THIS LIMITED WARRANTY DOES NOT APPLY TO ACCESSORY OR CONSUMABLE ITEMS, INCLUDING BATTERIES, RELATED TO THIS PRODUCT. ALL IMPLIED WARRANTIES SHALL BE LIMITED IN DURATION TO TWO YEAR FROM DATE OF PURCHASE. IN NO EVENT SHALL SELLER BE LIABLE FOR ANY INCIDENTAL OR CONSEQUENTIAL DAMAGES, INCLUDING BUT NOT LIMITED TO LIABILITY FOR LOSS OF PROFITS, ARISING FROM THE SALE OR USE OF THIS PRODUCT.

If any provision of this Limited Warranty is for any reason held to be invalid or unenforceable, such provision shall not affect any other provision herein, this Limited Warranty shall be construed as if such invalid and/or unenforceable provision had never been contained herein.

This warranty gives you special legal rights, and you may also have other rights which vary from state to state.

This Warranty contains the entire agreement between Seller and Buyer and supersedes any and all prior agreements, arrangements, or understandings between the parties relating to product warranty.

Due to ongoing product development
the actual product or products may vary from
the illustrations or photos shown within this manual.

For Manuals, Replacement Parts or Customer Service visit:
www.ezreplacement.com

Made in China

©2017 J & J Global LLC.

Distributed by:

J & J Global LLC.

Carrollton, TX 75006

Battery Replacement

NOTE: The batteries in your solar lantern come preinstalled from the factory. Remove the plastic battery protective tabs before first use.

1. (SEE FIGURE 7) Remove the screws from the top of the solar lamp head (A) as shown in figure 7.
2. Carefully lift the top off the housing. Remove the 2 screws from the bottom of the lantern top. Separate the top housing from the solar light panel. Batteries compartment is located on underside of the lantern as shown in figure 7.
3. Remove the old batteries.
4. Replace with 3 AA rechargeable type Ni-Mh batteries. Reference polarity direction inside the battery compartments.
5. Replace the solar light panel to the top housing and secure with 2 screws retained from step 2.
6. Replace the top on the lantern body and secure with 2 screws retained from step 1.

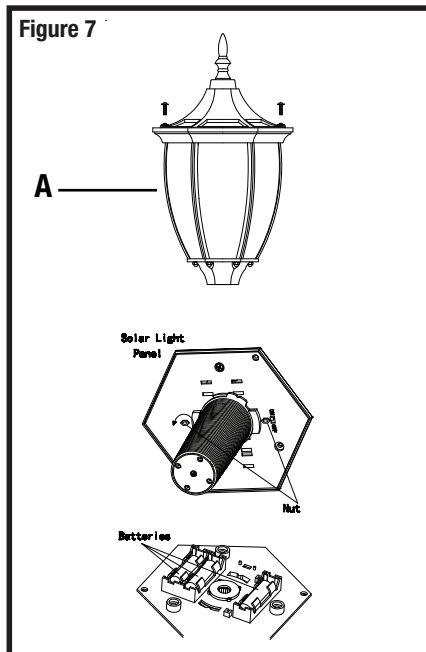

Installation Instructions

1. (SEE FIGURE 2) Screw the wall mount bracket (C) to a flat, vertical surface by drilling two holes and inserting the wall anchors. (use wall mount bracket as a template to determine hole location). Then align the wall anchors with the holes on the wall mount bracket and twist the screws in to hold in place.

2. Make sure the bracket is level, then tighten the center bracket screw.

3. Attach the lantern head onto the wall mount bracket. Use acorn nuts (D) to secure the lantern.

Figure 2

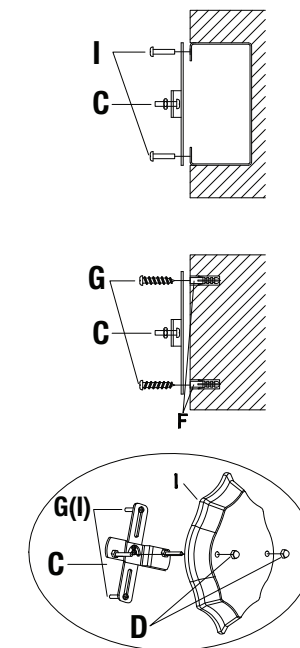

OPERATING SOLAR LIGHT

Instructions For First Time Use

Allow lantern to charge for at least 8 hours in full sunlight with the ON/OFF switch in the OFF position. The ON/OFF switch is located under the solar panel (See Figure 7, page 5). Once the batteries are fully charged, set the ON/OFF switch to ON. If the lantern doesn't turn on after initial charging, ensure batteries are making contact with the terminals.

Where To Place the Solar Light

Place the solar light in an area where it will receive direct sunlight for at least 8 hours per day. The number of hours light is illuminated is directly proportional to the number of hours of sunlight it receives. If the light is placed in a shaded area, it will not be able to fully charge and its burn time will be limited. Do not place the light near other outdoor lighting like porch or streetlights. These may fool the sensor and keep the light from coming on, or cause it to turn off automatically.

