

CHIRP

Upgrade Your Sounder to a Serious Fishfinding Machine!
Only possible with the use of an AIRMAR broadband transducer.

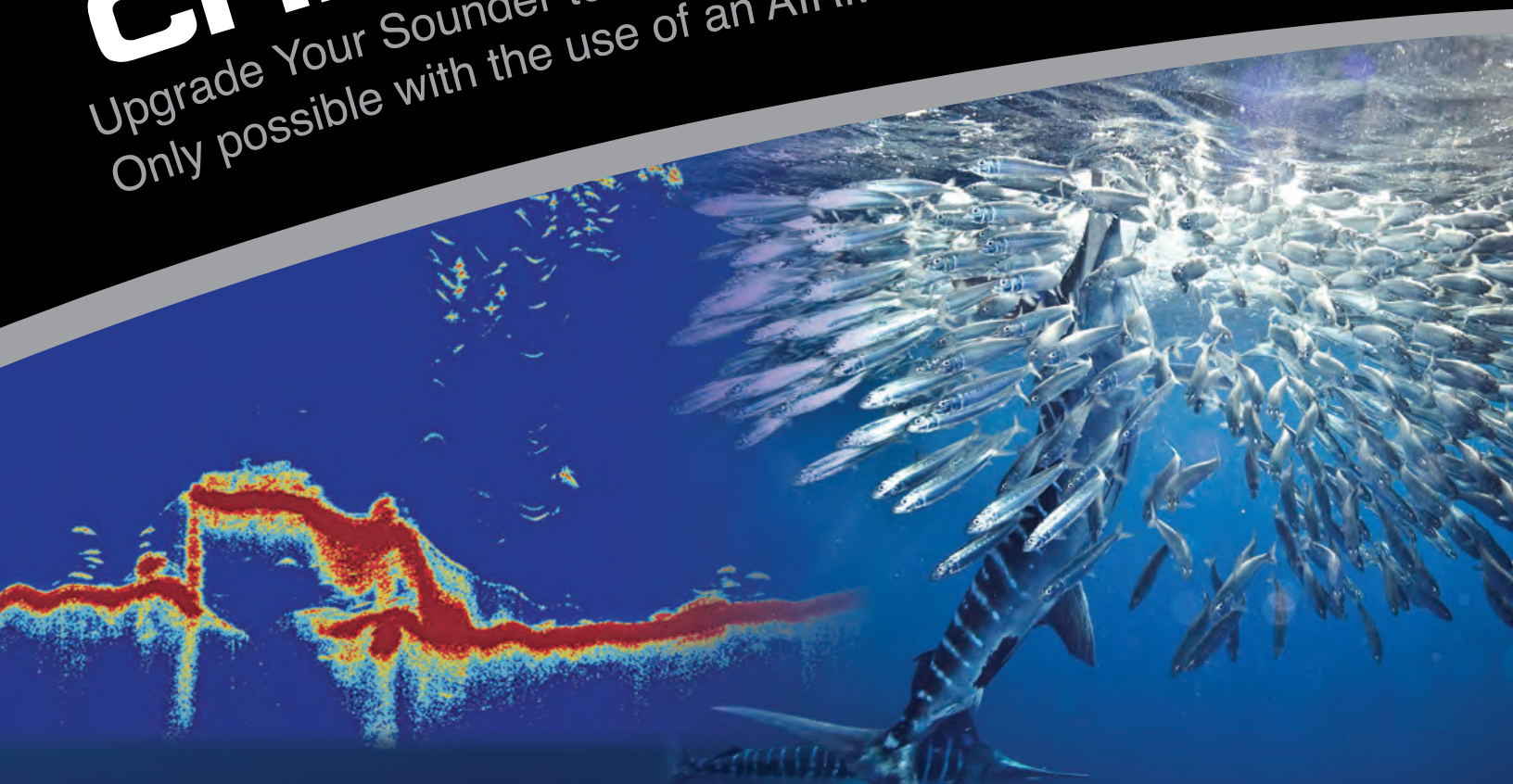

CHIRP TECHNOLOGY

- 5 to 10 times greater detail and resolution
- 10 to 1,000 times more energy on targets
- Accuracy down to 3,000 m (10,000')
- Precise separation between baitfish and game fish
- Superior performance in noisy environments
- Improved bottom tracking at high boat speeds

**DEEPER.
BROADER.
CLEARER.**

GAME CHANGING TECHNOLOGY.

AIRMAR[®]
TECHNOLOGY CORPORATION

Sensing Technology

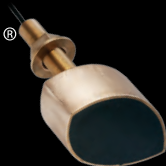

Thru-Hull

Screen shot courtesy of Garmin[®].

Broadband / CHIRP Transducers

When Your Living Depends on Finding Fish...

Rely on Airmar's new broadband transducers for the ultimate fishing mission. Whether you're a commercial fisherman, charter captain, or tournament angler, there's a new game in town! CHIRP transducers enable bottom detection down to 3,000 m (10,000') with 5 to 10 times greater detail and resolution so precise it's possible to distinguish between individual baitfish, game fish, and underwater structures. One transducer delivers up to 117 kHz of total bandwidth in just one installation, saving customers time and money.

Airmar...it's what's under your boat.

The CHIRP Difference

Traditional marine fishfinders operate at discrete frequencies such as 50 kHz and 200 kHz, use relatively short-duration transmit pulses, and use narrowband sonar transducers. In contrast, CHIRP (compressed high-intensity radar pulse) uses a precise sweep pattern of many frequencies within a long-duration transmit pulse from a broadband transducer, so the equivalent sound energy transmitted into the water is 10 to 1,000 times greater than a conventional marine fishfinder. The echo energy returning to the transducer, superior to that generated by a conventional transducer, is then processed by the fishfinder's DSP (digital signal processing) computer and displayed in ultra-sharp detail on the display. The combination of CHIRP, a broadband transducer, and the fishfinder's DSP, results in dramatically better fish and bottom detection, superior depth capability, and significantly better performance at speed.

Does YOUR Fishfinder CHIRP?

Only CHIRP/Spread Spectrum sounders using Airmar broadband transducers can operate as a CHIRP fishfinder system. When Airmar's new transducer is paired with a broadband fishfinder, the result is 5 to 10 times greater sensitivity and performance than current fishfinder technology. Packed with exclusive technology like Transducer ID® and newly engineered piezoceramic elements, Airmar transducers are über sensitive and designed to automatically sweep frequency bands from 28 kHz to 210 kHz with no tuning necessary. As a result, all targets detected in the entire bandwidth will be seen on the display rather than only what is identified in traditional frequencies at 50 kHz and 200 kHz.

Airmar's complete line of twenty-four (24) CHIRP transducers are available in seven (7) different mounting options to accommodate almost any hull design. CHIRP transducers are available at Gemeco Marine Accessories www.gemeco.com and Airmar EMEA www.airmar.com/emea. Visit www.AIRMAR.com for a list of CHIRP-ready transducers.

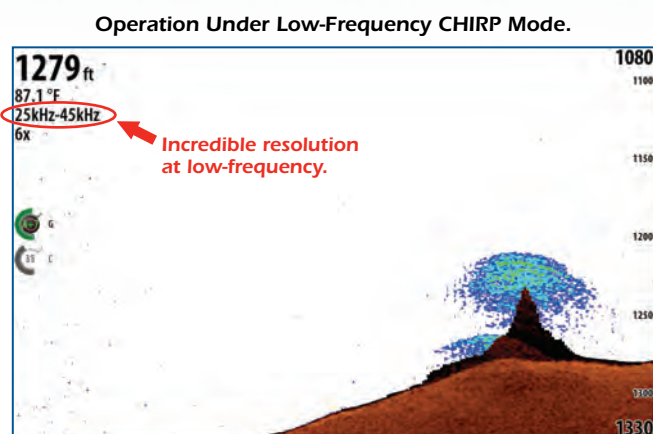
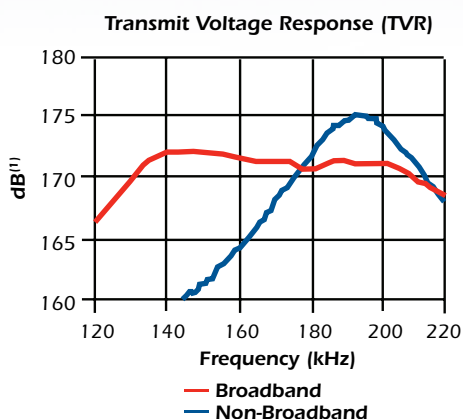

Screen shot courtesy of Simrad®.

CORE

Thru-Hull

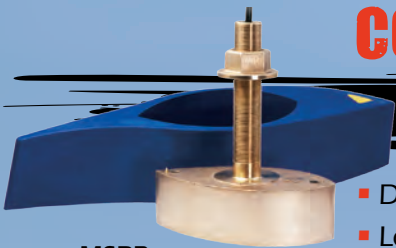

B265LH (Low & High-Frequency)

MSRP
\$1,700.00
€1,400.00

- Depth & fast-response water-temperature sensor
- Low—CHIRPS from 42 kHz to 65 kHz
25° to 16° beamwidth
- High—CHIRPS from 130 kHz to 210 kHz
10° to 6° beamwidth
- 103 kHz of total bandwidth from one transducer
- Covers popular fishing frequencies of 50 and 200 kHz plus everything else in the bandwidth
- Fishing Profile: Commercial and recreational inshore and offshore fishing (deep-water canyon and sea-mount tracking)
- Bronze transducer housing with High-Performance Fairing
- Boat Size: 8 m (25') and above
- Hull Type: Fiberglass or wood

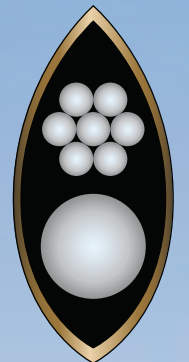

8-Internal Broadband Ceramic Assemblies

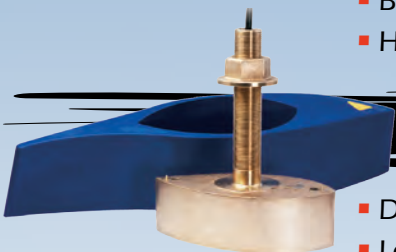

B265LM (Low & Medium-Frequency)

MSRP
\$1,885.00
€1,538.00

Medium-frequency benefits include the ability to sound deeper than the high-frequency, along with better target resolution than the low-frequency.

- Depth & fast-response water-temperature sensor
- Low—CHIRPS from 42 kHz to 65 kHz
25° to 16° beamwidth
- Medium—CHIRPS from 85 kHz to 135 kHz
16° to 11° beamwidth
- 73 kHz of total bandwidth from one transducer
- Covers popular fishing frequencies of 50, 88, and 107 kHz plus everything else in the bandwidth
- Fishing Profile: Commercial and recreational inshore and offshore fishing (deep-water canyon and sea-mount tracking)
- Bronze transducer housing with High-Performance Fairing
- Boat Size: 8 m (25') and above
- Hull Type: Fiberglass or wood

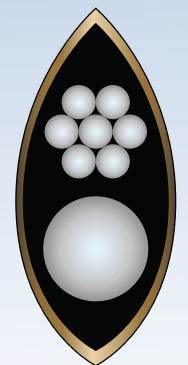

8-Internal Broadband Ceramic Assemblies

DIMENSIONS

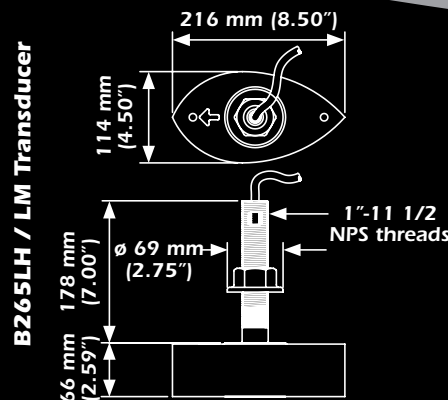
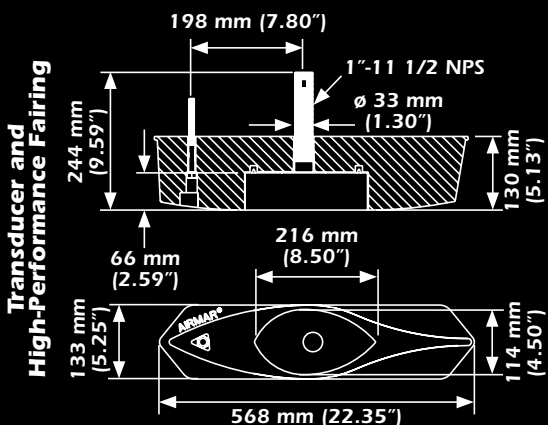

HARD-CORE

Thru-Hull



R109LH (Low & High-Frequency)

MSRP
\$3,060.00
€2,620.00

- Depth & fast-response water-temperature sensor
- Low—CHIRPS from 38 kHz to 75 kHz
19° to 10° beamwidth
- High—CHIRPS from 130 kHz to 210 kHz
8° to 4° beamwidth
- 117 kHz of total bandwidth from one transducer
- Covers popular fishing frequencies of 38, 50, and 200 kHz plus everything else in the bandwidth
- Fishing Profile: Commercial and recreational inshore and offshore fishing (deep-water canyon and sea-mount tracking)
- Urethane transducer housing with High-Performance Fairing
- Boat Size: 12 m (40') and above
- Hull Type: Fiberglass, wood, or metal

16-Internal
Broadband Ceramic
Assemblies

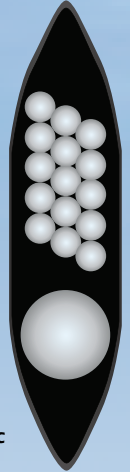

R109LM (Low & Medium-Frequency)

MSRP
\$3,250.00
€2,780.00

Medium-frequency benefits include the ability to sound deeper than the high-frequency, along with better target resolution than the low-frequency.

- Depth & fast-response water-temperature sensor
- Low—CHIRPS from 38 kHz to 75 kHz
19° to 10° beamwidth
- Medium—CHIRPS from 80 kHz to 130 kHz
13° to 8° beamwidth
- 87 kHz of total bandwidth from one transducer
- Covers popular fishing frequencies of 38, 50, 88, and 107 kHz plus everything else in the bandwidth
- Fishing Profile: Commercial and recreational inshore and offshore fishing (deep-water canyon and sea-mount tracking)
- Urethane transducer housing with High-Performance Fairing
- Boat Size: 12 m (40') and above
- Hull Type: Fiberglass, wood, or metal

16-Internal
Broadband Ceramic
Assemblies

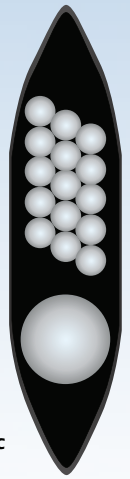

DIMENSIONS

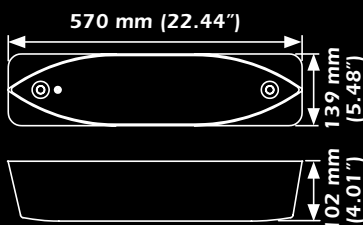

R109LH / LM
Transducer

Installing the
Transducer

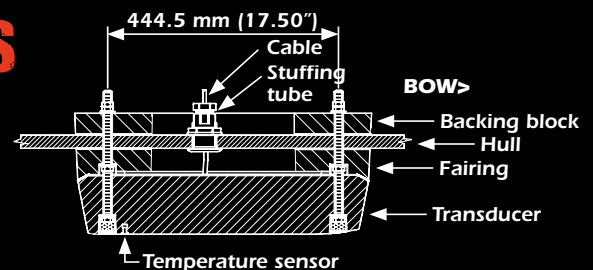

ELITE

Thru-Hull



R509LH (Low & High-Frequency)

MSRP
\$4,299.00
€3,620.00

- Depth & fast-response water-temperature sensor
- Low—CHIRPS from 28 kHz to 60 kHz
23° to 9° beamwidth
- High—CHIRPS from 130 kHz to 210 kHz
8° to 4° beamwidth
- 112 kHz of total bandwidth from one transducer
- Covers popular fishing frequencies of 28, 38, 50, and 200 kHz plus everything else in the bandwidth
- Fishing Profile: Commercial and recreational inshore and offshore fishing (deep-water canyon and sea-mount tracking)
- Epoxy transducer housing with High-Performance Fairing
- Boat Size: 12 m (40') and above
- Hull Type: Fiberglass, wood, or metal

25-Internal
Broadband Ceramic
Assemblies

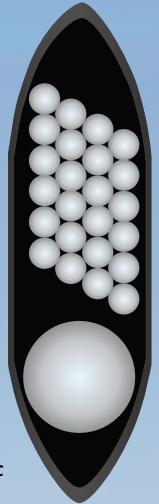

R509LM (Low & Medium-Frequency)

MSRP
\$4,495.00
€3,937.00

Medium-frequency benefits include the ability to sound deeper than the high-frequency, along with better target resolution than the low-frequency.

- Depth & fast-response water-temperature sensor
- Low—CHIRPS from 28 kHz to 60 kHz
23° to 9° beamwidth
- Medium—CHIRPS from 80 kHz to 130 kHz
13° to 8° beamwidth
- 82 kHz of total bandwidth from one transducer
- Covers popular fishing frequencies of 28, 38, 50, 88, and 107 kHz plus everything else in the bandwidth
- Fishing Profile: Commercial and recreational inshore and offshore fishing (deep-water canyon and sea-mount tracking)
- Epoxy transducer housing with High-Performance Fairing
- Boat Size: 12 m (40') and above
- Hull Type: Fiberglass, wood, or metal

25-Internal
Broadband Ceramic
Assemblies

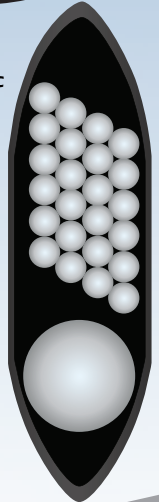

DIMENSIONS

R509LH / LM
Transducer

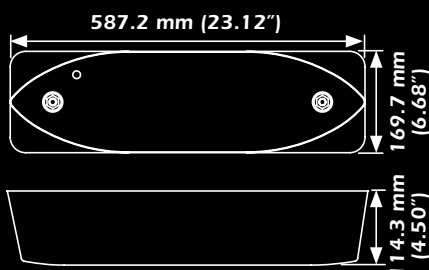

Installing the Transducer

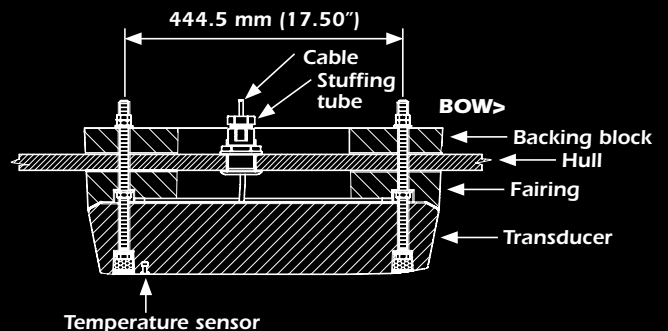

Technical Information

Advantages of Thru-Hull Transducers

Best performance, minimal drag, designed for larger boats, works with any hull material.

When external thru-hull transducers are installed with a High-Performance Fairing, the transducer face is parallel to the waterline resulting in a beam that is vertically oriented for maximum echo returns and the best possible performance. The fairing compensates for hull deadrise and reduces turbulence over the transducer face, which allows tracking at speeds over 30 knots (35 MPH). This installation, when mounted in “clean water” (forward of propellers and running gear), produces the most effective signal return since nothing on the vessel interferes with the transducer’s active surface. Thru-hull transducers will work with any engine type: inboard, outboard, or I/O.

See *Guide to Transducer Technology* to compare Thru-Hull, In-Hull, Pocket / Keel-Mount, and Transom-Mount options. www.airmar.com

Unique Transducer ID®

Airmar’s Transducer ID feature measures and stores the operating parameters for each transducer. This enables the fishfinder to automatically configure itself to the transducer being used. The embedded microcontroller continuously monitors ceramic operating temperatures inside the transducer, enabling closed loop control of power output. The transducer’s profile can be presented on the display showing beamwidth coverage as a function of frequency. Stored data also assists with troubleshooting, warranty or any required information about the transducer.

Quality “Q” Value

Q is a measure of bandwidth and the rise and fall times of target echoes. Airmar Q values range from 1.6 to 30, depending on the model. Competitive transducers have an average Q of 25 to 30. The lower the “Q” number, the less ringing in the transducer and the better the performance—improved individual fish separation along with bottom imaging in rapidly changing water depths such as ledges and offshore canyons.

All Airmar CHIRP transducers have a Q of 3 or less.

Model	Q / Bandwidth		Roundtrip Sensitivity*	
	LF	HF	LF	HF
B45 (baseline)**	28 / 1.8 kHz	30 / 6.7 kHz	1 times	1 times
B260**	9 / 6 kHz	8 / 25 kHz	250 times	50 times
B265	2.2 / 23 kHz	2 / 80 kHz	1,000 times	120 times
R109	1.6 / 37 kHz	2 / 80 kHz	4,100 times	225 times
R509	1.6 / 37 kHz	2 / 80 kHz	6,100 times	240 times

*All roundtrip sensitivity data is based on the Figure of Merit (FOM) and the transducer bandwidth relative to the B45 model.

**Commonly used non-CHIRP transducers.

See *Theory of Operation* for a complete understanding of transducer terminology and operation. www.airmar.com