

## Dehumidifier Consorb **CS-5, 5L**



*Dehumidifying capacity at 20°C / 60%RH*

**0,35 - 0,4 kg/h**

*Dry air flow*

**65 - 90 m<sup>3</sup>/h**

- ✓ Easy to place
- ✓ Very low sound-level
- ✓ Low weight
- ✓ Washable rotor
- ✓ No desiccant carry-over
- ✓ Stainless steel chassis
- ✓ Self-regulating heater
- ✓ Easy to maintain
- ✓ Long lifetime

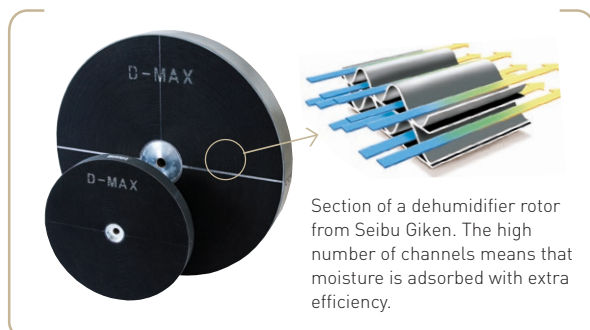

TECHNICAL DATA

Dehumidifier model	CS-5	CS-5L
Nominal capacity <sup>1</sup> (kg/h)	0,35	0,4
Dry air flow <sup>2</sup> (m <sup>3</sup> /h)	65	90
at external static pressure (Pa)	50	100
Wet air flow <sup>2</sup> (m <sup>3</sup> /h)	30	50
at external static pressure (Pa)	30 <sup>3</sup>	30 <sup>3</sup>
Heater current <sup>3</sup> [A]	2,8	3,5
Total power (kW)	0,7	0,85
Supply fuse 230V / 50Hz (A)	10	10
Weight (kg)	9	9

<sup>1</sup> Valid for inlet conditions 20°C / 60%RH.

<sup>2</sup> Volume flow for density 1,20 kg/m<sup>3</sup>.

<sup>3</sup> The design of the PTC heater enables the power to be regulated by controlling the wet air flow.

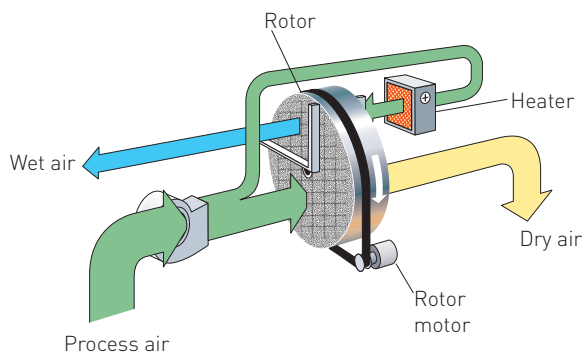

DIMENSIONS

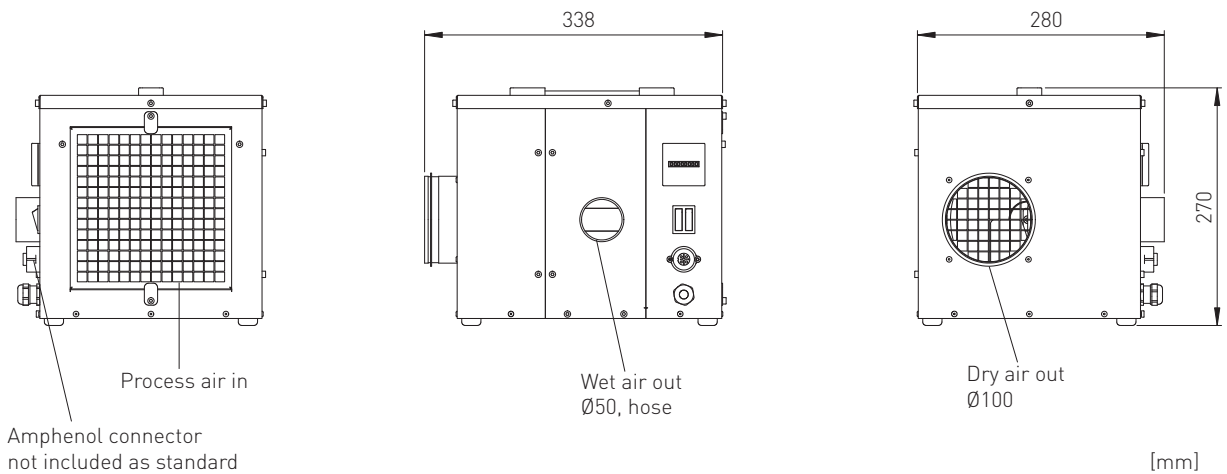

Subject to change without notice. Download installation drawing at [www.dst-sg.com](http://www.dst-sg.com)

Seibu Giken DST AB

Avestagatan 33 | 163 53 Spånga, Sweden

Tel +46 8 445 77 20 | Fax +46 8 445 77 39

[www.dst-sg.com](http://www.dst-sg.com) | [info@dst-sg.com](mailto:info@dst-sg.com)

CONTACT US

(+52) 55 4324 7603 / 777 380 2414 / 777 420 2408

Rio Mayo 1477, Int. 11  
Cuernavaca, Morelos 62290 - Mexico