

Dehumidifier Consorb
DC-10



Dehumidifying capacity at 20°C / 60%RH

0,6 kg/h

Dry air flow

190 m³/h

- ↘ Washable rotor
- ↘ No desiccant carry-over
- ↘ Stainless steel chassis
- ↘ Self-regulating heater
- ↘ Easy to maintain
- ↘ Long lifetime

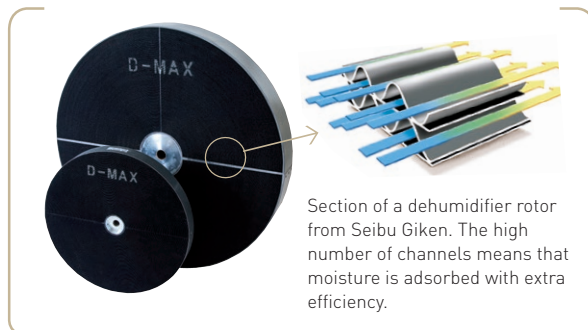

TECHNICAL DATA

Dehumidifier model	DC-10
Nominal capacity ¹ (kg/h)	0,6
Dry airflow ² (m ³ /h)	190
Normal wet air flow ² (m ³ /h)	60
Heater current ³ (A)	4,5
Maximum electric consumption (kW)	1,3
Supply fuse 230V / 50Hz (A)	10
Weight (kg)	15

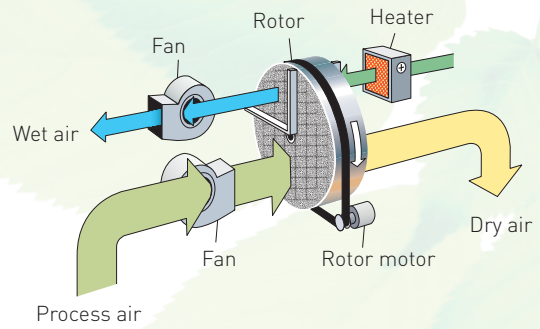

- ¹ Valid for inlet conditions 20°C/60%RH. For other inlet conditions the capacity can be calculated by using the correction factor from the diagram shown below.
- ² Volume flow for density 1,20 kg/m³. Free blowing.
- ³ The design of the PTC heater enables the power to be regulated by controlling the wet air flow.

CORRECTION DIAGRAM

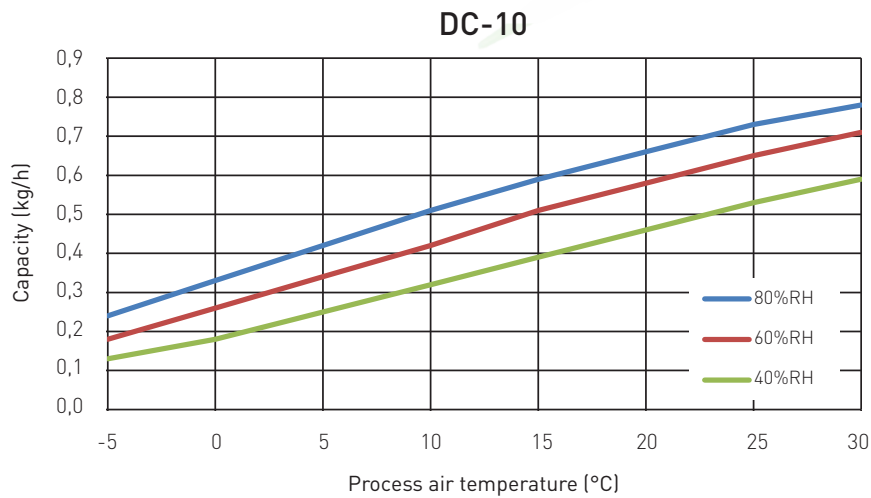

DIMENSIONS

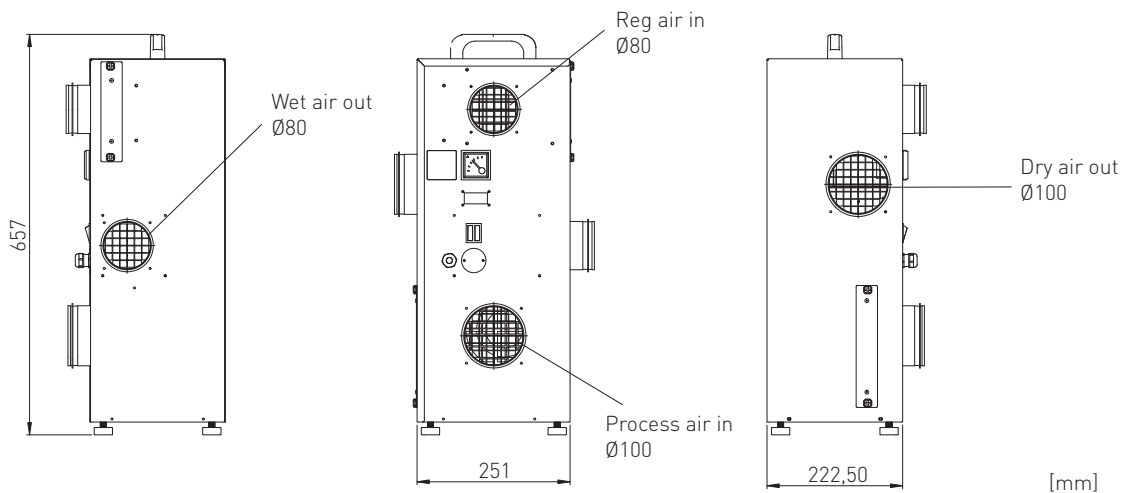

Subject to change without notice. Download installation drawing at www.dst-sg.com.

Seibu Giken DST AB

Avestagatan 33 | 163 53 Spånga, Sweden

Tel +46 8 445 77 20 | Fax +46 8 445 77 39

www.dst-sg.com | info@dst-sg.com

CONTACT US

(+52) 55 4324 7603 / 777 380 2414 / 777 420 2408

Rio Mayo 1477, Int. 11
Cuernavaca, Morelos 62290 - Mexico