

REVISIONS			
REV.	DESCRIPTION	DATE	APPROVED
01	Recommended reduction added	2013-10-31	KS
02	Reg fan with outlet on opposite side added	2016-09-08	AD

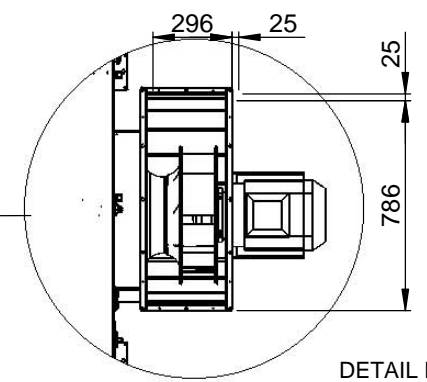

DETAIL B
SCALE 1 : 20

This document and its contents are the exclusive property of DST Seibu Giken and must not be copied, reproduced, transmitted or communicated to any other party or used for purposes not expressly permitted by us.

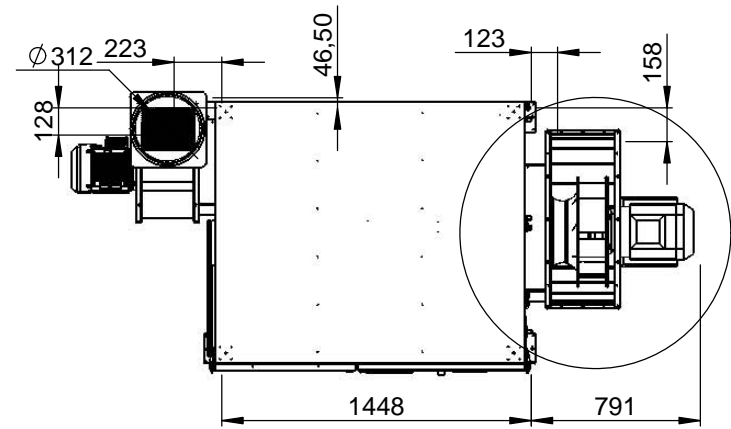
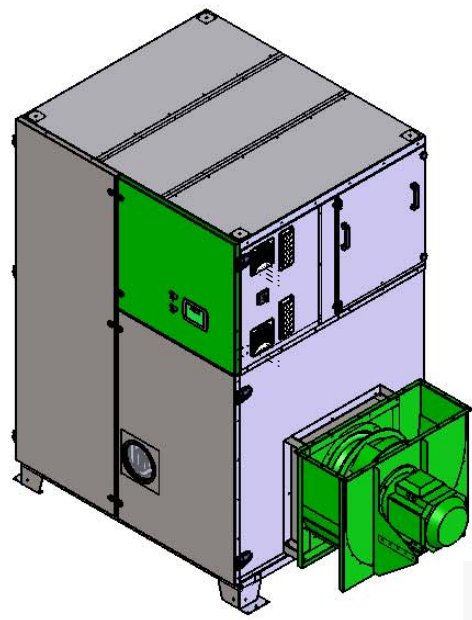
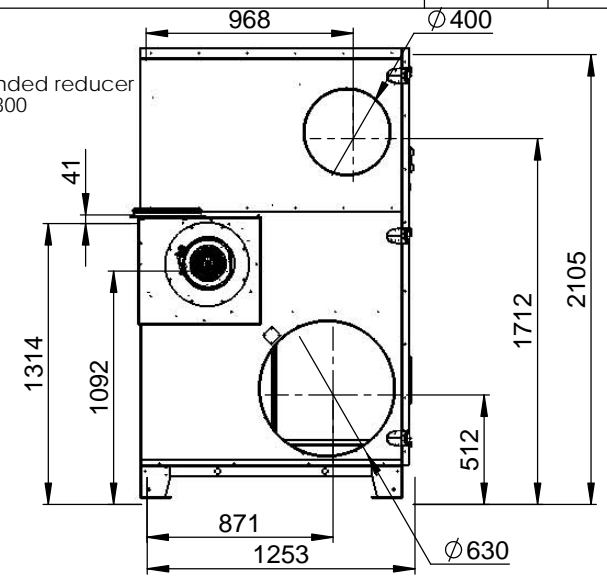
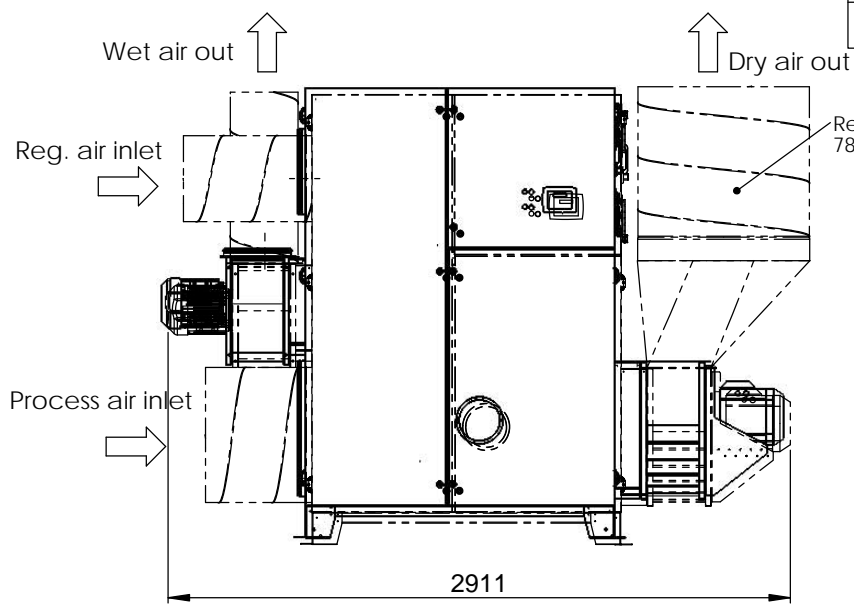
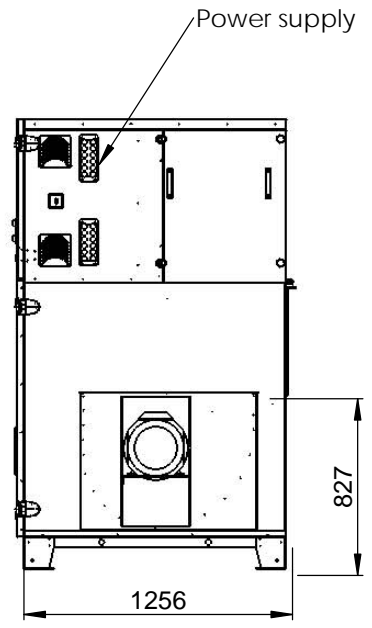

CONTACT US

(+52) 55 4324 7603 / 777 380 2414 / 777 420 2408
Rio Mayo 1477, Int. 11
Cuernavaca, Morelos 62290 - Mexico



Seibu Giken DST AB
+46 8 445 77 20
www.dst-sg.com

Designed by	Catarina S	Date	2011-03-03
Drawn by	Catarina S	Date	2011-03-03
Approved by	-	Date	-
Material	-	Thickness	t=
Status	Construction	Tolerance	ISO 2768-1m
Scale	1:25	Format	A3
Sheets/Sheet	1/1	Rev Part	02+
Weight (Kg)	560		

Title/Description	
Installationsritning CZ-104 Installation drawing	
CZ-104	
Drawing no	Rev
DST02572	02+