

TECHNICAL REQUIREMENTS

- 1.The connection standard conforms to AWWA C606 and other groove connection standards
- 2.Working pressure is 365PSI

	DN50	DN65	DN80	DN100	DN125	DN150	DN200	DN250	DN300
A	85	95	108	122	140	158	269	297	372
B	65	68	80	90	105	120	150	170	195
L	169	203	213	245	267	292	356	432	495
ØD	Ø60.3	Ø73	Ø88.9	Ø114.3	Ø141.3	Ø168.3	Ø219.1	Ø273	Ø323.85
		Ø76.1			Ø139.7	Ø165.1			

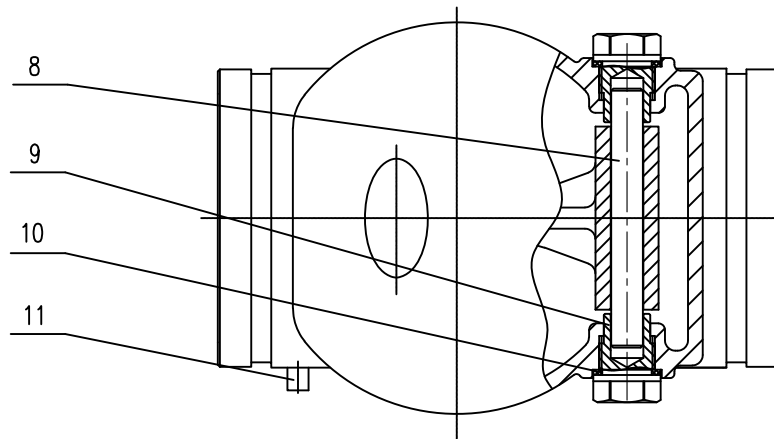

12	Eyebolt (8" and above)	SS304
11	Plug	SS304
10	Plug the gasket	EPDM
9	Shaft hole plug	SS304
8	Shaft	SS304
7	Split pin	SS304
6	Hexagonal slot thin nut	SS304
5	Washer	SS304
4	Swing arm	A351 CF8
3	Disc	Q235+SS304+EPDM
2	Seat	C83600
1	Body	A536
NO.	NAME	MATERIAL

Manufacture/Supplier:

SHOP DRAWING

FIG NO. 7200

SENTRY SPRINKLERS

REV.	BY	APP.	Description	Date

DRAWN		Date	
Checked		Date	
Approved		Date	
Projection		ALL DIM'S IN: mm DO NOT SCALE FROM DRAWING	

TITLE:	SWING CHECK VALVE GROOVED-END 2"-12"(DN50-DN300)
DRAWING NO. :	