

# PFA151

## Corner Mount Bracket

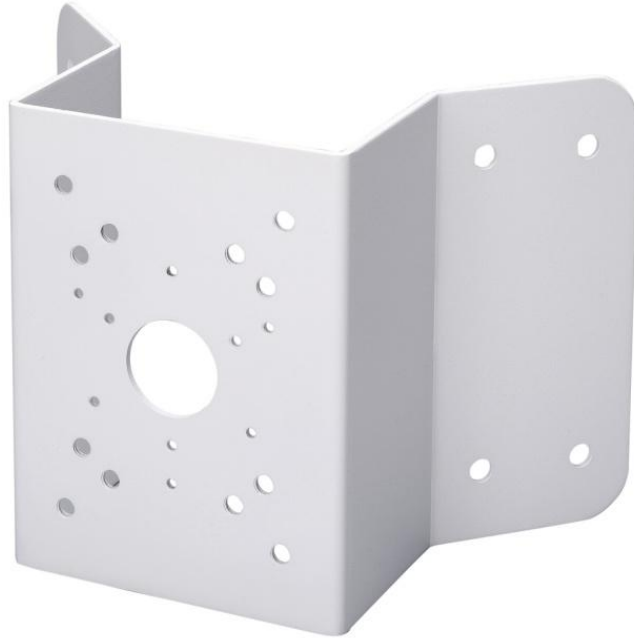

### Features

- Material: SECC
- Corner Mount Bracket
- Neat & Integrated design

### Specifications

Model	PFA151
<b>General</b>	
Material	SECC
Dimension (W x H x D)	243mm x 170mm x 138mm
Pipe Thread	N/A
Operating Temperature	-40°C ~60°C
Humidity	0~90% RH
Load Bearing	10.0Kg
Weight	1.7Kg

# PFA151

## Dimensions (mm)

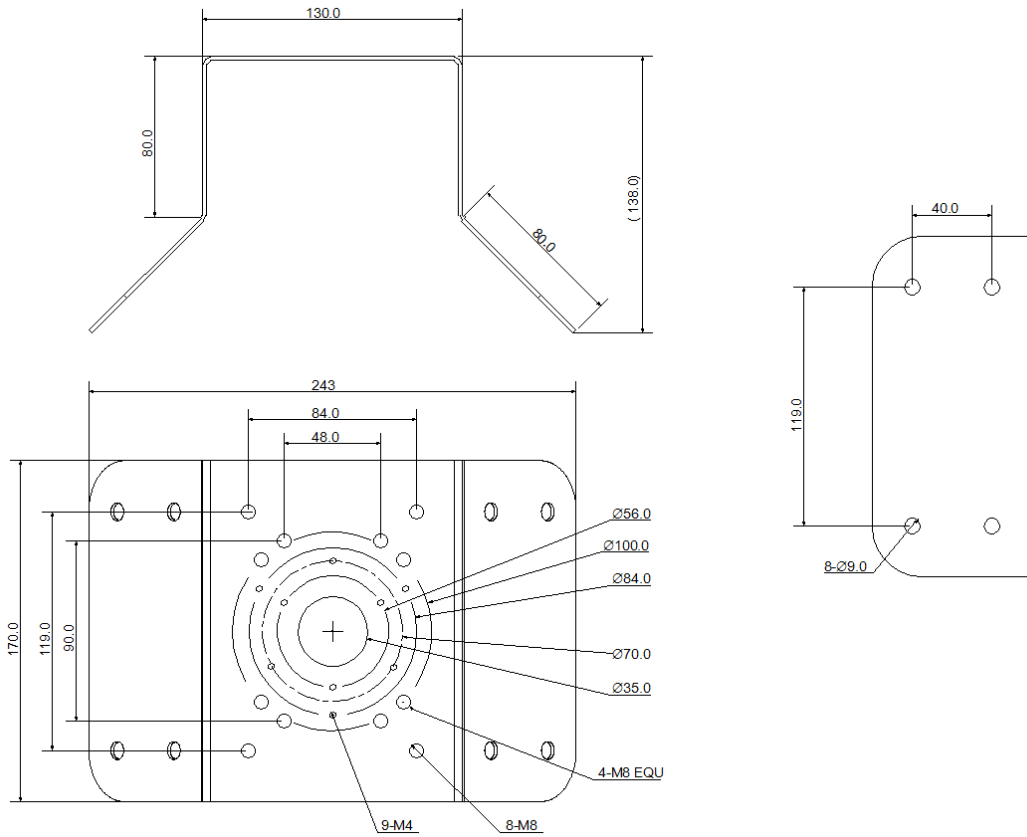

## Application

