

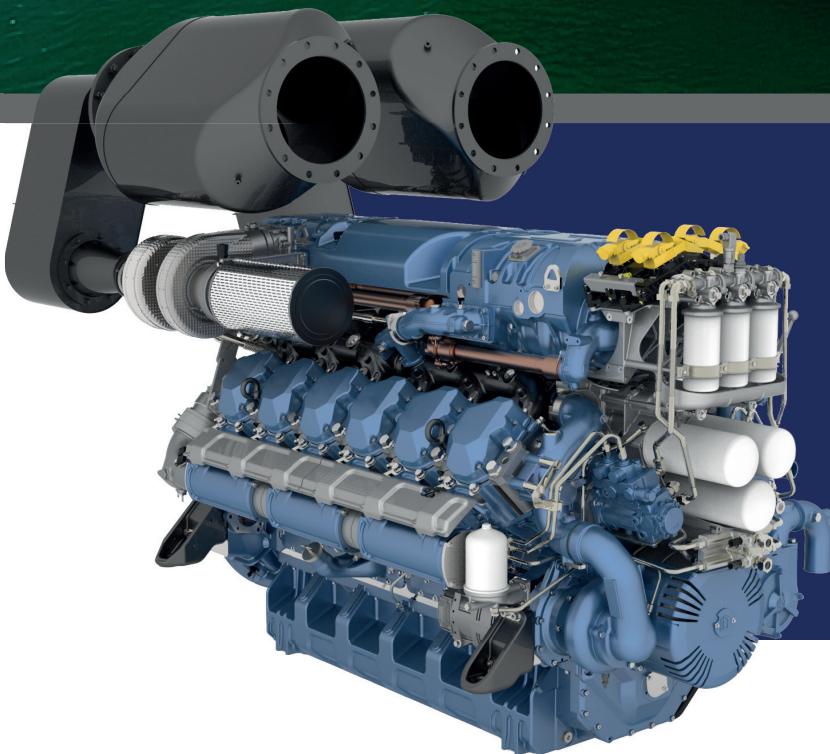

Marine Advanced Emissions Technology



**IMO III & EPA IV
Certified Solutions**

Meeting Higher Emission Standards

Marine engines are subject to ever-increasing exhaust gas emissions restrictions. Baudouin is proud to be one of only a few high speed engine manufacturers offering an IMO III and EPA Tier IV Certified Solution. Our advanced engines comply with the latest standards defined for international seas, US coasts and recreational crafts.

In 2016, the International Maritime Organisation (IMO) introduced the Tier III norm, requiring a reduction of NOx emissions. Already active in Canada for new build and repowered vessels over 750 kW, the IMO III regulation will be extended to Northern Europe in 2021 for vessels over 130 kW (new build and repowered).

In the the USA, EPA Tier IV has required a reduction of NOx emissions of 70% and a reduction of particulates of 40% below the Tier III standard.

Uncompromising Technology

Our Advanced M26.3 engines meet the IMO III and EPA Tier IV requirements, delivering superior fuel economy without compromising engine power.

We have completely redesigned the combustion cycle by reworking the injection system and the combustion chamber, and recalibrating the injection parameters. This achieves a cleaner engine with improved performance without sacrificing reliability. We developed an optimized Selective Catalyst Reduction System (SCR) to meet the stringent requirements of IMO III and EPA Tier IV standards.

The SCR system is smaller, lighter and more flexible than most solutions available today on the market, reducing costs and space requirements for our customers while maximizing product reliability.

Superior Installation Flexibility

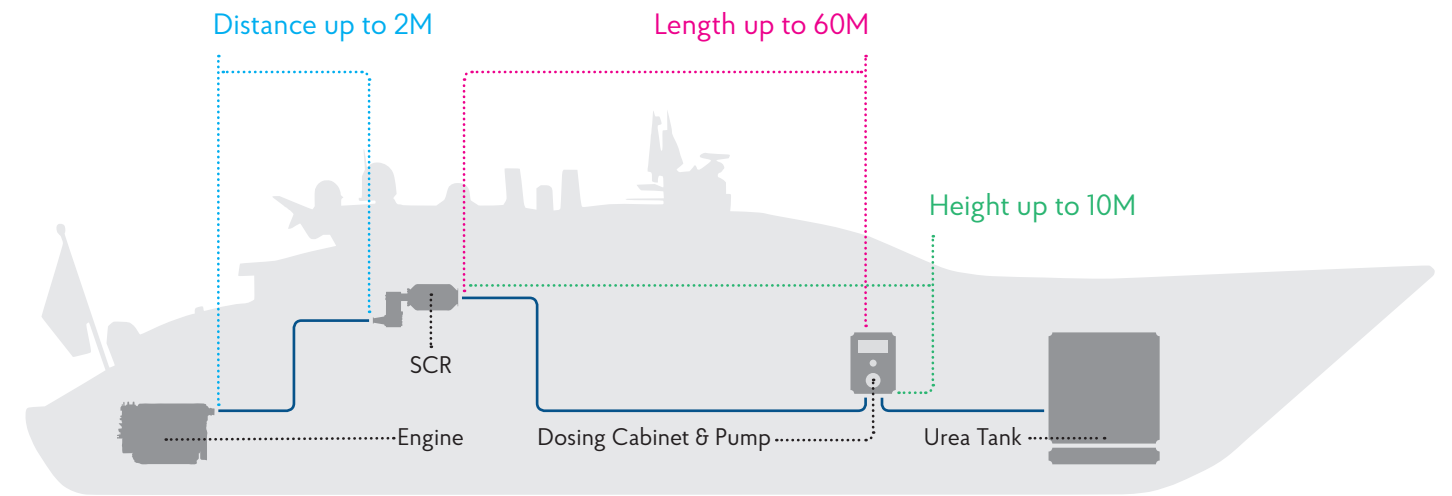

Advanced Engines with SCR

6 M26.3

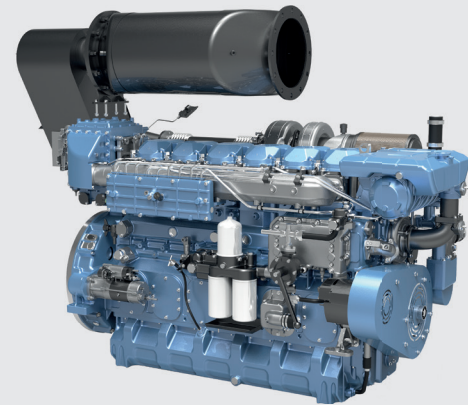

Number of cylinders:	6 in line
Bore and stroke:	150 x 150 mm
Total displacement:	15.90 L
Dry Weight:	2185 kg

Common-rail injection

Rating	kW	Hp	rpm
Continuous Duty	441	600	1800
Heavy Duty	515	700	2000
Heavy Duty	551	750	2100
Light Duty	599	815	2100

Genset

Model	Hz	kWm	kWe	KVA
PRP	50	440	416	520
PRP	60	501	472	590

12 M26.3

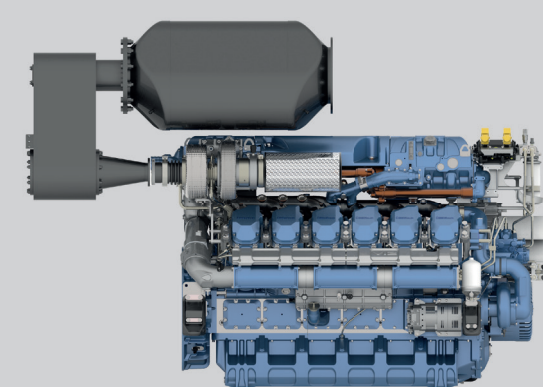

Number of cylinders:	12 V @ 90°
Bore and stroke:	150 x 150 mm
Total displacement:	31.80 L
Dry Weight:	3615 kg

Common-rail injection

Rating	kW	Hp	rpm
Continuous Duty	883	1200	1800
Heavy Duty	1030	1400	2100
Heavy Duty	1104	1500	2200
Light Duty	1214	1650	2300

Genset

Model	Hz	kWm	kWe	KVA
PRP	50	880	840	1050
PRP	60	1002	955	1195

A Compact, Flexible System

Designed with our customers' individual needs in mind, the compact Baudouin SCR system can be installed in a variety of configurations to suit every vessel design.

The system provides the freedom to place the tank, pump and cabinet up to 60 meters away from the catalyst. Plus, the system itself can be mounted up to 2 meters away from the engine. This means you are not restricted to placing the whole system in the engine room, but can create a bespoke solution for your individual vessel's layout.

- + Easily integrated into the propulsion line
- + Repower and new build vessels
- + Generous system component layouts
- + Adaptable SCR mounting configurations
- + A compact 'airless' urea dosing system means no additional installation is required

A Dynamic Catalyst

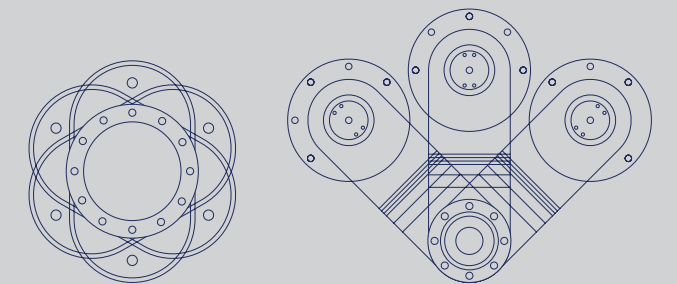

The Baudouin SCR catalyst adapts to any vessel layout. The system can rotate 360° on its axis to allow maximum mounting flexibility. In addition, the catalyst is 1m³ in volume, one of the smallest available on the market.

Adaptable Configurations

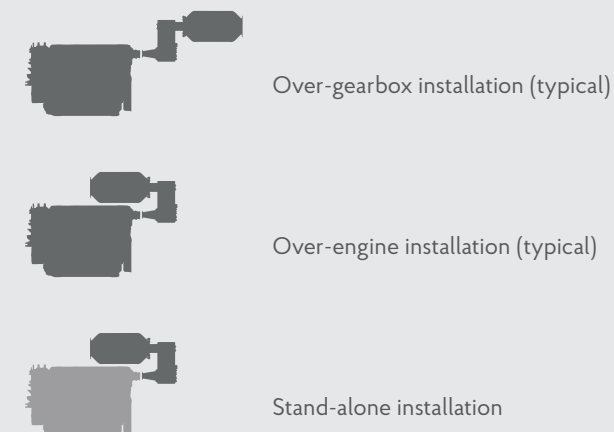

Our Advanced Engines Deliver

- + A cleaner engine with the same power
- + Up to 5% reduction in average fuel consumption
- + An extremely compact, modular design
- + Superior installation flexibility
- + Up to 25 dB noise reduction
- + Optimized maintenance schedule in line with the engine



Full Design Support

We offer full design support, to help you integrate the Baudouin SCR System into your vessel design, whether it is a new or repowering project.

Our experts can advise on mounting, storage, maintenance, and dimensioning of the urea storage tank volume. They can also provide 3D models and drawings to assist, so the system is perfectly installed and ready to use

Count on Baudouin to help you navigate your transition to IMO III and EPA IV.

Contact your distributor for more information:
www.baudouin.com/our-network

 **MOTEURS**
Baudouin

