

Set-up Instructions

COPY

1979-1982 Models ATC70



AMERICAN HONDA MOTOR CO., INC.
100 WEST ALONDRA BOULEVARD, GARDENA, CALIFORNIA 90247

JUL 23 1981

WARNING

WARNING

WARNING

WARNING

SET-UP AND PRE-DELIVERY SERVICE MUST BE PERFORMED BY AN AUTHORIZED HONDA MOTORCYCLE DEALER. Proper set-up and pre-delivery service is essential to rider safety and reliability of the motorcycle. When a customer takes delivery of his brand new motorcycle, he expects it to be in excellent running condition. There are few things that will cause greater customer dissatisfaction than poor preparation of a new motorcycle. An error or oversight made by the mechanic assembling and servicing a new unit can easily result in faulty operation, damage to the machine, or even injury to the rider.

THIS ISSUE OF THE ATC70 SET-UP INSTRUCTIONS REPLACES THE 1979-1981 MODELS ATC70 SET-UP INSTRUCTIONS DATED 7/80. REMOVE AND DESTROY SUPERSEDED SET-UP INSTRUCTIONS.

1982 Model shown; 1979, 1980, and 1981 Models similar



NOTE:

- All steps apply to the 1979 through 1982 Models unless otherwise noted.
- Right and left are determined from the rider's view.

SET-UP INSTRUCTION REVISED PAGES

Pages Affected	Orig. Issue Date	Rev. Date
1 through 13	7/81	Original

Remove and destroy superseded pages.

Pay special attention to warnings, cautions, and notes.

WARNING means hazards or unsafe practices which could cause severe personal injury or death.

CAUTION: means hazards or unsafe practices which could cause minor personal injury or product or property damage.

NOTE: gives helpful information.

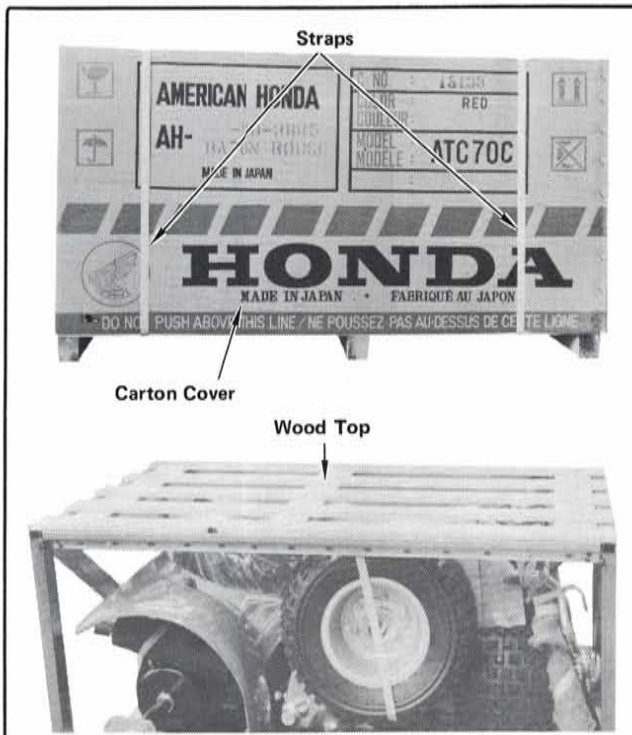

STEP 1—Cut straps and carefully lift off carton cover. Remove crate wood top.

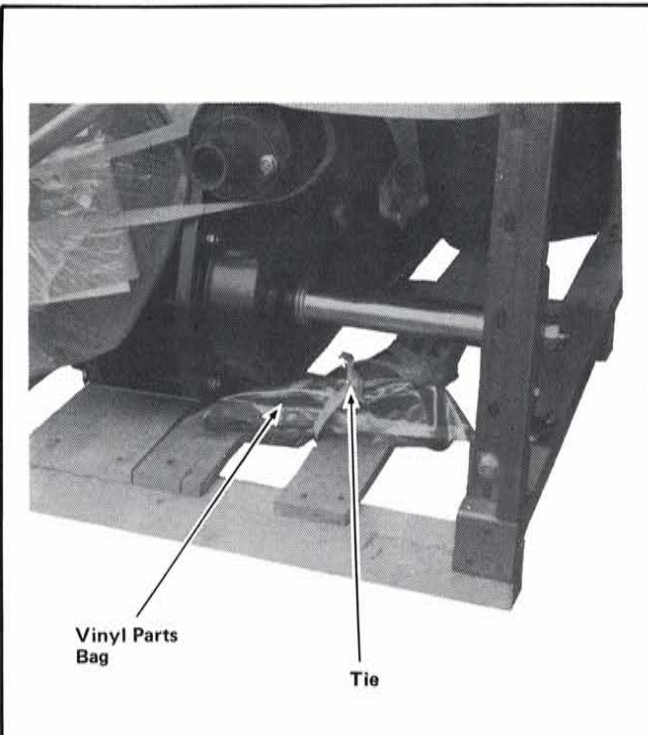

STEP 2—Remove tie holding vinyl parts bag to crate base.

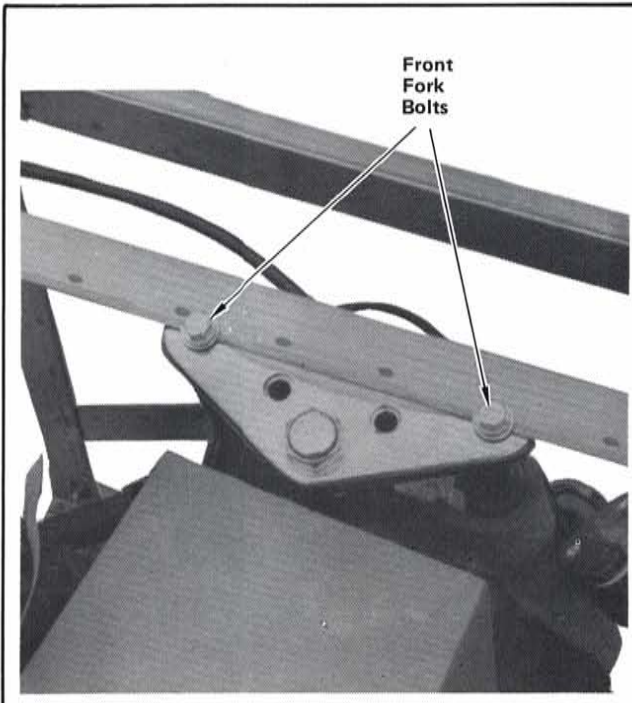

STEP 3—Loosen two front fork bolts.

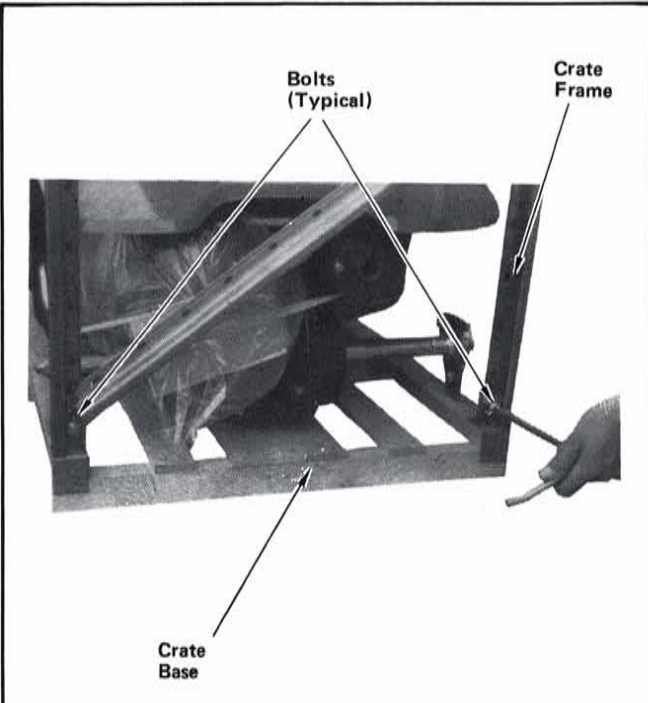

STEP 4—Remove four bolts (two on each end) attaching steel crate frame to crate base and carefully lift off crate frame.

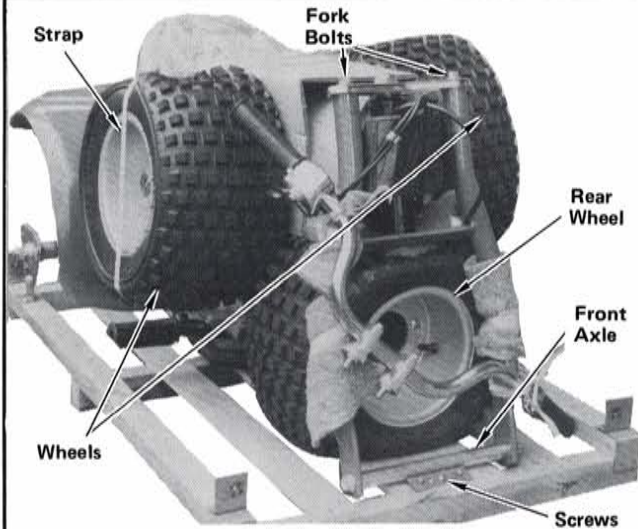

STEP 5—Cut strap holding front and rear wheels. Remove wheels. Retighten front fork bolts to specified torque.

Torque specification:
 4.5 kg-m (32 lb-ft)

Remove three screws attaching front axle to crate base. Discard screws. Remove rear wheel from behind front forks.

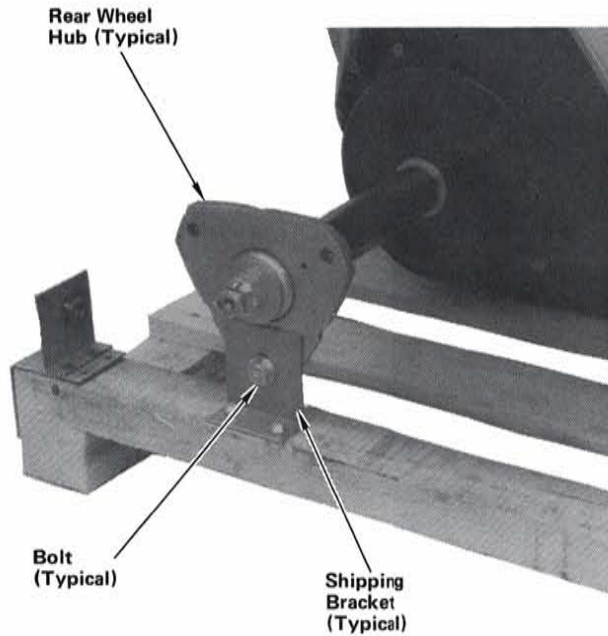

STEP 6—Remove two bolts (one on each side) attaching rear wheel hubs to lower shipping brackets. Discard bolts.

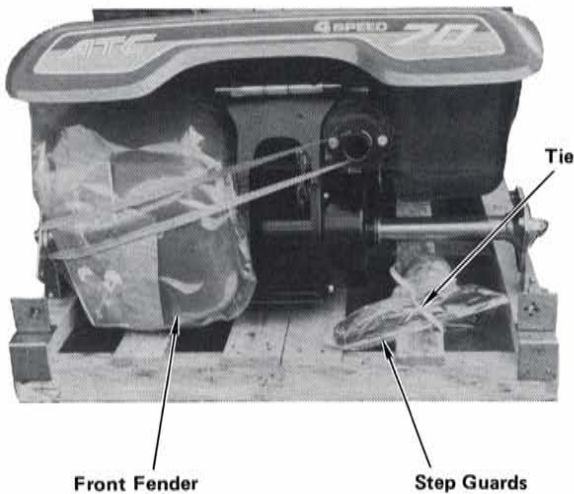

STEP 7—Remove front fender from under rear fender by removing rubber band. On 1982 Model, remove step guards by removing tie.

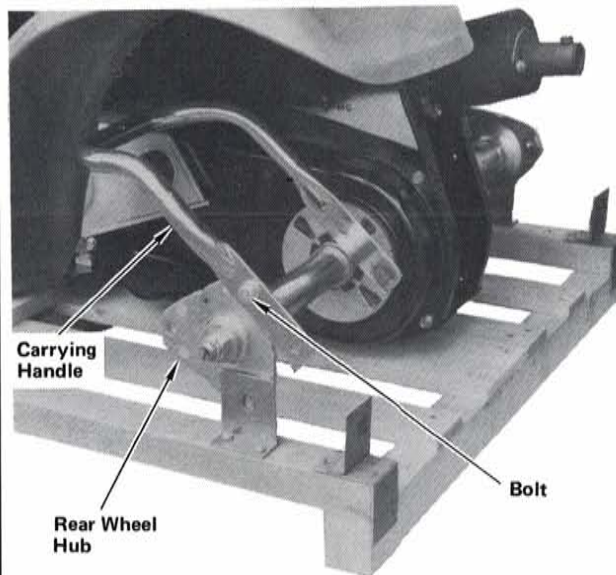

STEP 8—Remove bolt attaching carrying handle to wheel hub and remove carrying handle. Discard bolt.

1979, 1980 Parts Shown, 1981 and 1982 Similar

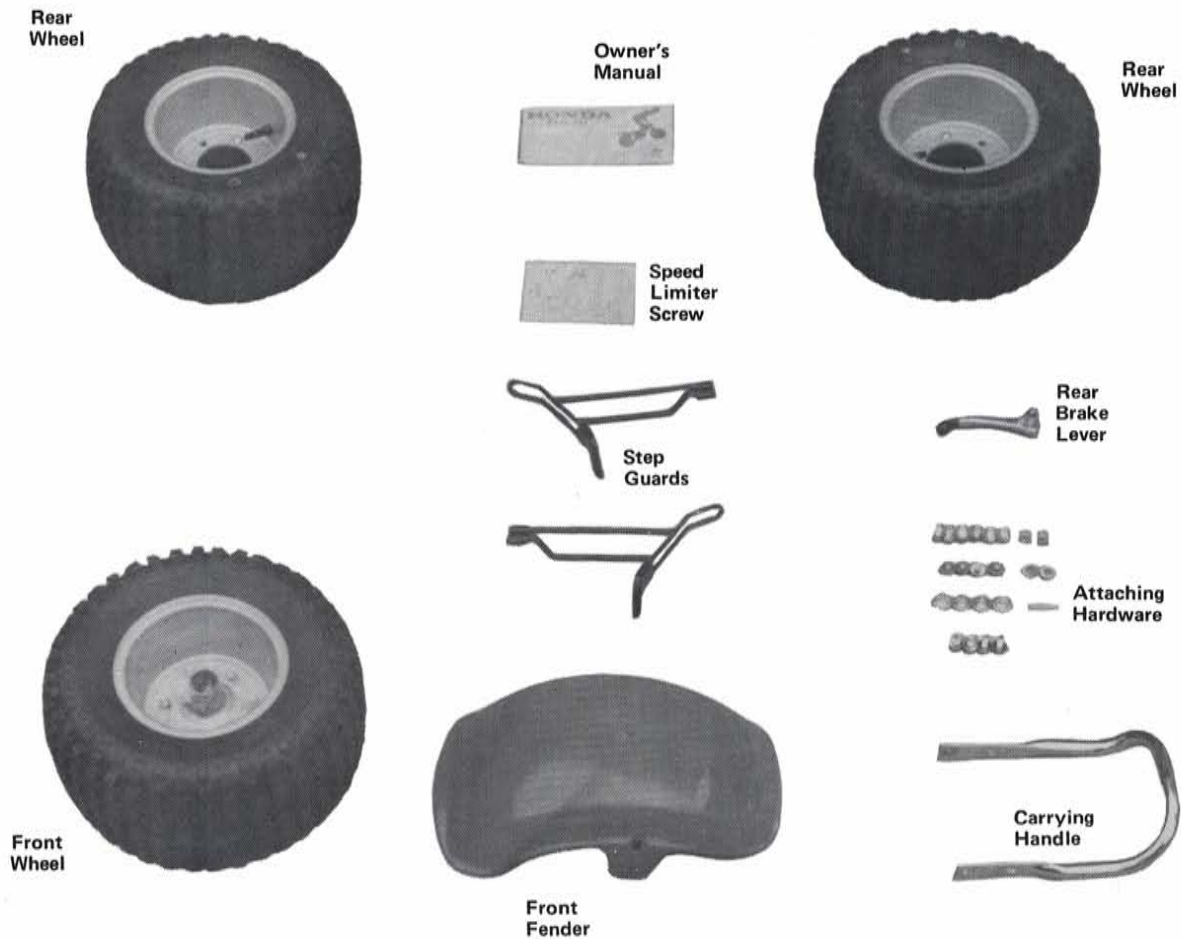

STEP 9—Unpack remaining loose parts and check against this illustration. Report any damaged or missing parts immediately to American Honda Motor Co., Inc., 100 West Alondra Blvd., Gardena, California 90247.

Damaged or Missing Parts

Identify missing parts by referring to the "Loose Parts List" at the end of the set-up. Order parts through normal parts ordering procedures.

It is necessary to differentiate between parts lost or damaged in transit, and parts left out by the factory.

- For parts lost or damaged in transit, file a SHIPPING DAMAGE CLAIM.
- For parts left out by the factory, file a WARRANTY CLAIM W.O.2.

Refer to the Warranty Policy and Procedures Manual (SO 945) under **Shipping Damage and Crate Shortage** for further information.

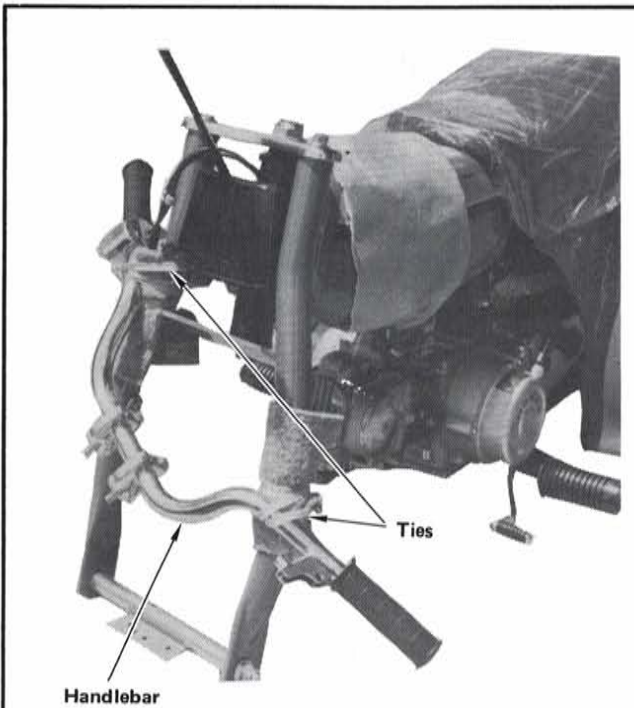

STEP 10—Remove ties holding handlebar to front fork legs.



STEP 11—Install handlebar on upper fork bridge as shown using two 10mm lock washers and nuts. Tighten nuts to specified torque.

Torque specification:
4.5 kg-m (32 lb-ft)

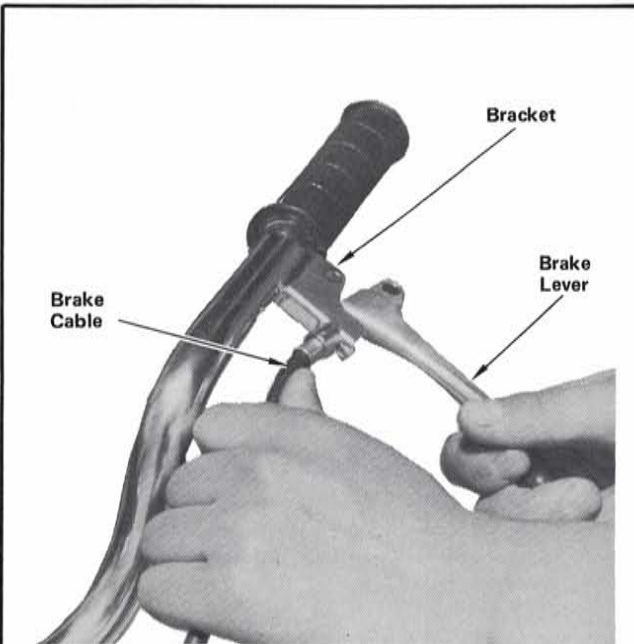

STEP 12—Route brake cable in front of throttle cable and insert end of rear brake cable into slot in brake lever. Pull cable back through slot in brake lever bracket.

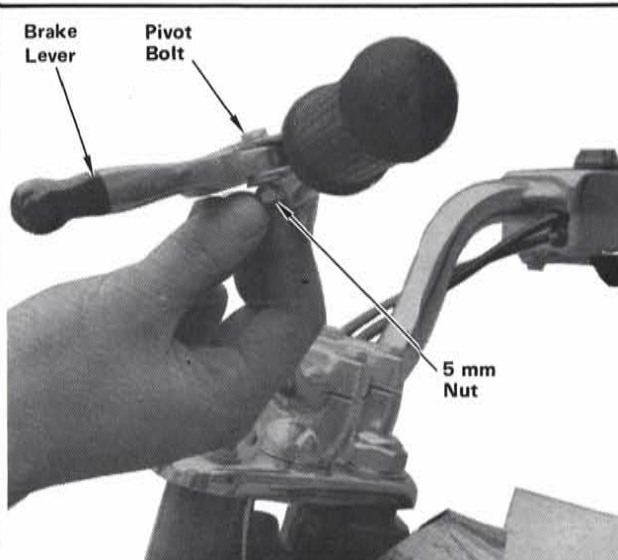

STEP 13—Install rear brake lever on bracket using a brake lever pivot bolt and 5mm nut. Tighten nut securely.

CAUTION: Check that brake lever operates freely.

Adjust rear brake as described in owner's manual or shop manual.

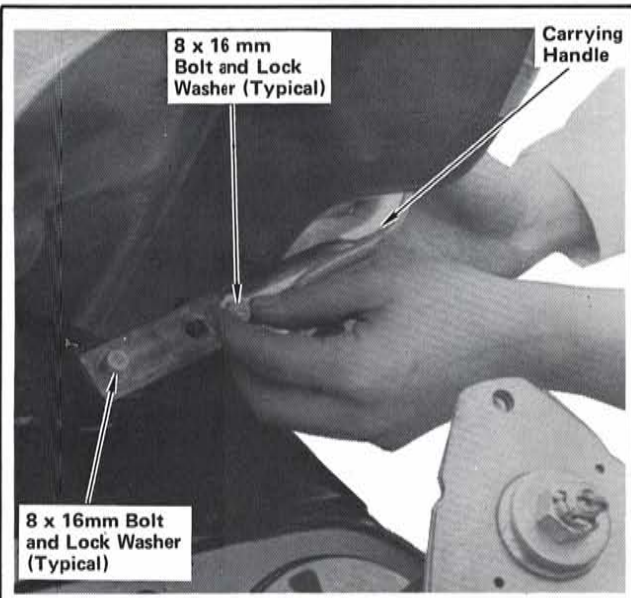

STEP 14—Install carrying handle on frame, with curved end up, using two 8 x 16mm bolts and lock washers through front holes, and two 8 x 16mm bolts and lock washers through rear holes. Tighten bolts to specified torque.

Torque specification:
2.2 kg-m (16 lb-ft)

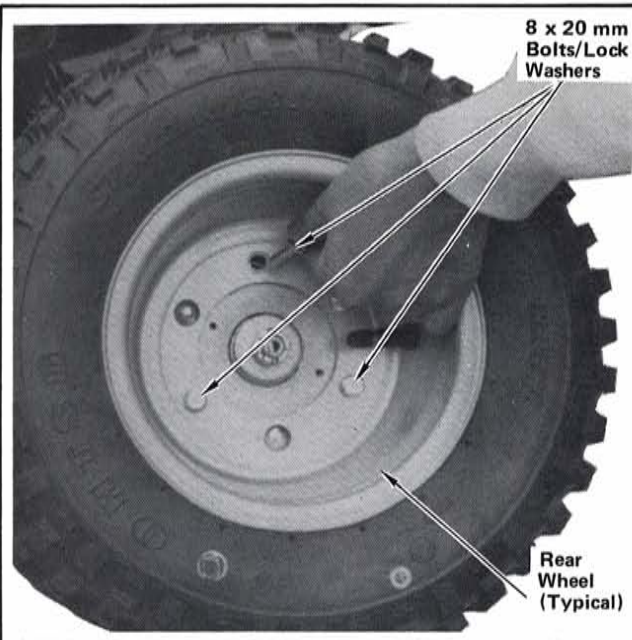

STEP 15—Inflate rear tires to 2.2 psi. Install rear wheels as shown using three 8 x 20mm bolts/lock washers for each. Tighten bolts to specified torque.

Torque specification:
2.2 kg-m (16 lb-ft)

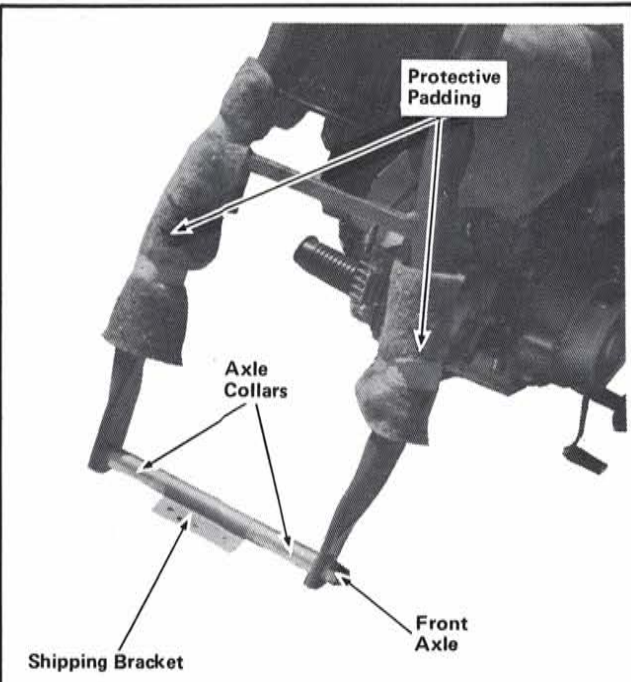

STEP 16—Remove all protective padding from front forks. Remove and clean front axle and axle collars. Discard shipping bracket. Place a padded block under engine so front forks are raised.

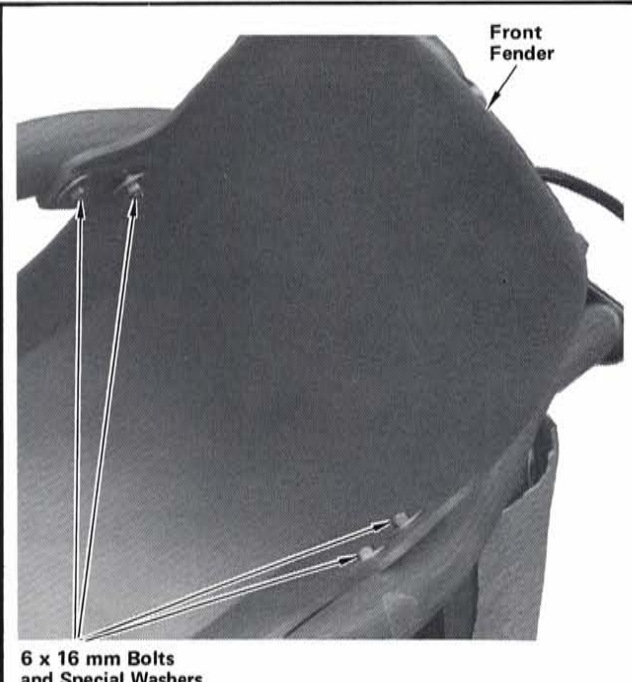

STEP 17—Position front fender between fork legs with short end forward. Install front fender using four 6 x 16mm bolts and special washers. Tighten bolts securely.

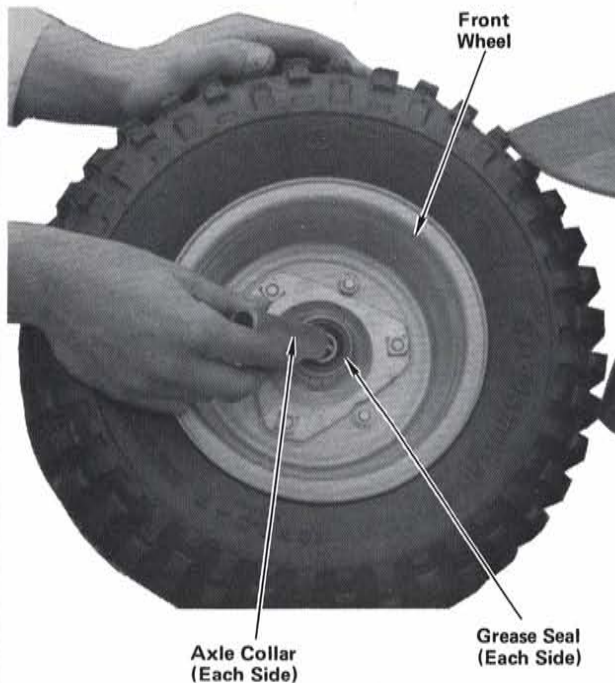

STEP 18— Insert axle collars into front wheel grease seals. Inflate front tire to 2.2 psi.

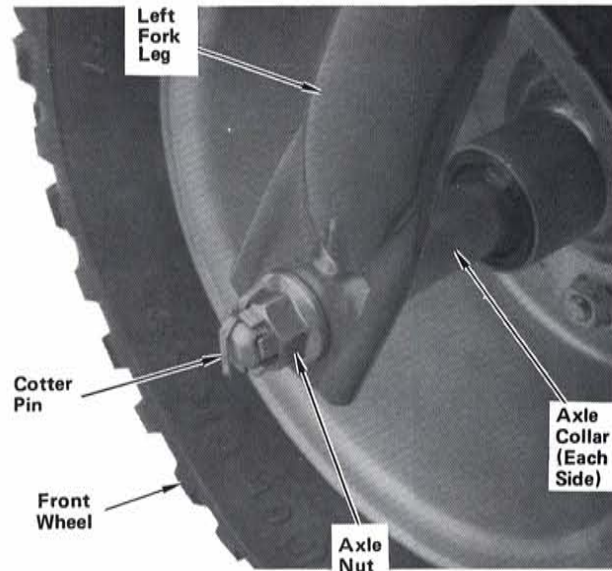

STEP 19— Position front wheel between fork legs with valve stem on left side. Insert axle from right side, through right fork leg, axle collar, wheel hub, axle collar, and left fork leg. Install axle nut and tighten nut to specified torque.

Torque specification:
7 kg-m (51 lb-ft)

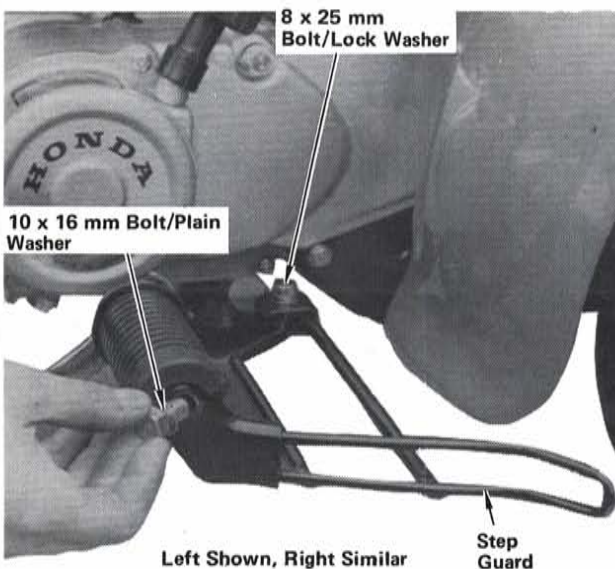

STEP 20— Install right and left step guards as shown using a 10 x 16 mm bolt/plain washer and an 8 x 25 mm bolt/lock washer for each. Tighten bolts to specified torque.

Torque specifications:
8 mm bolts: 2.2 kg-m (16 lb-ft)
10 mm bolts: 4.5 kg-m (32 lb-ft)



STEP 21— Remove crankcase drain plug and drain engine oil. Reinstall and tighten drain plug.

NOTE: Not required if less than 4 months have elapsed since date of manufacture shown on identification plate on steering head.

Refill crankcase with recommended oil as described in owner's manual or shop manual.

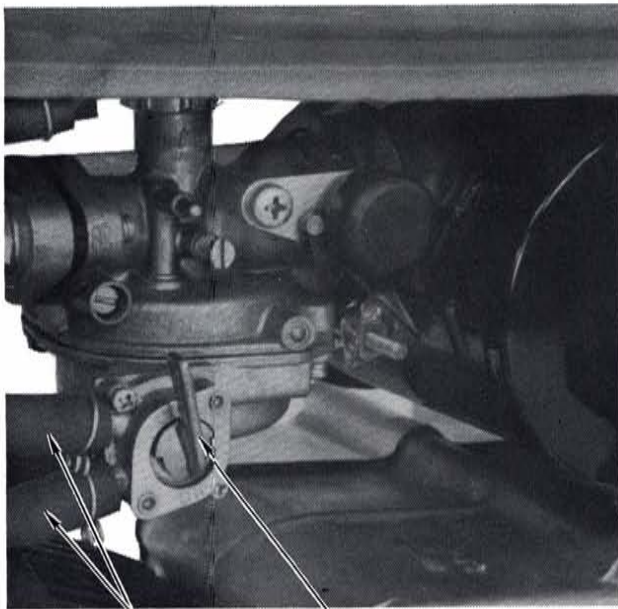

Fuel Lines Fuel Petcock

STEP 22—Inspect fuel tank. If necessary, drain and flush fuel tank by removing fuel lines. Reconnect fuel lines, fill tank, turn on fuel petcock and check for leaks.

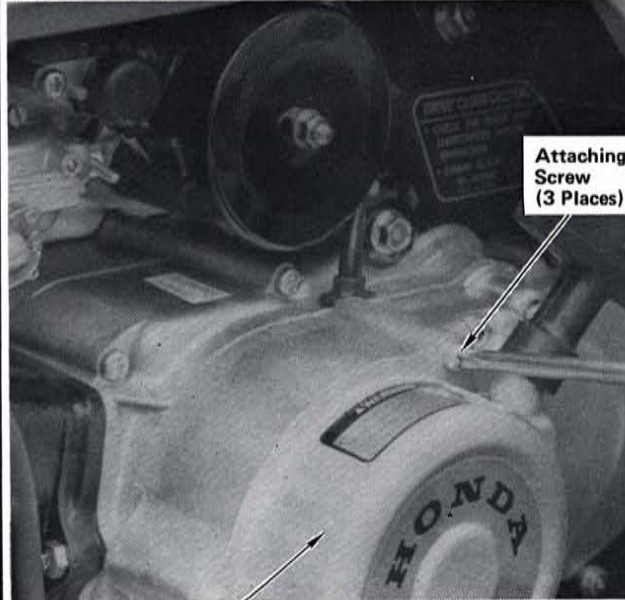

Attaching Screw (3 Places)

Recoil Starter

STEP 23—Remove recoil starter by removing three screws. Retain screws for reinstallation.

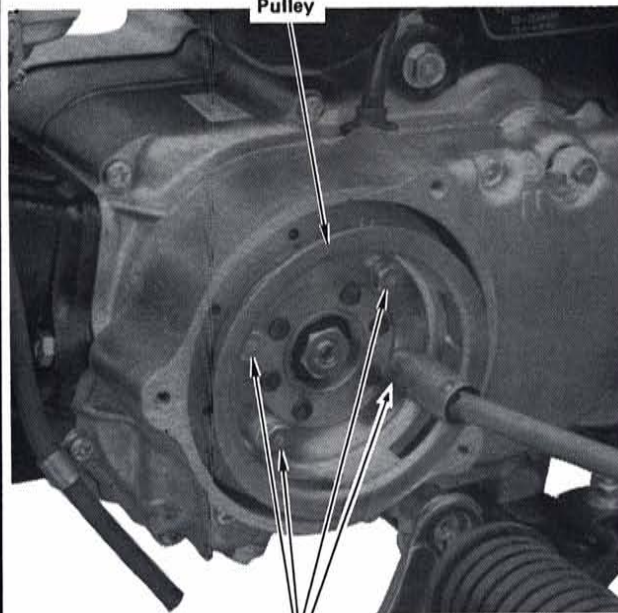

Starter Pulley

Attaching Bolts

STEP 24—Remove starter pulley by removing four 6mm hex bolts and lock washers. Retain bolts for reinstallation.

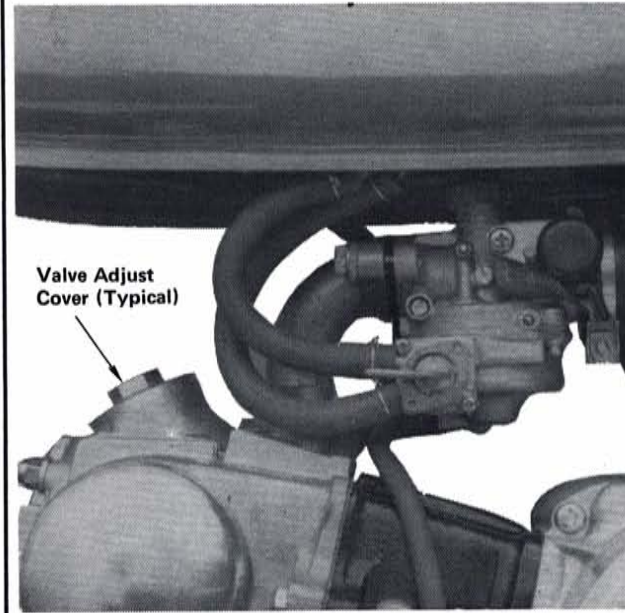

Valve Adjust Cover (Typical)

STEP 25—Remove valve adjust covers.

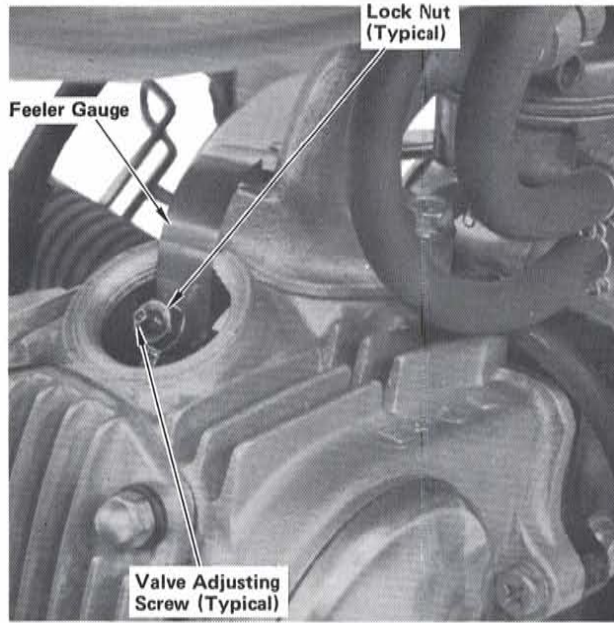
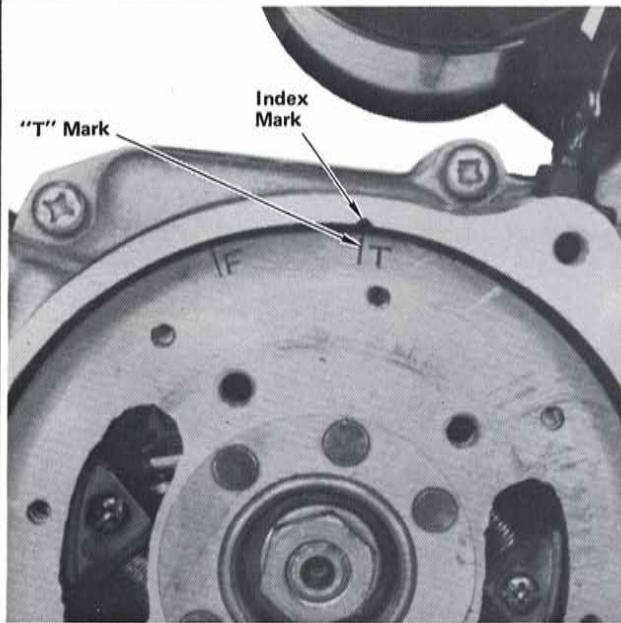

STEP 26—Turn flywheel counterclockwise to the “T” mark with piston on compression. Check valve clearance, and if necessary, adjust valve clearance as described in owner’s manual or shop manual. Reinstall tappet covers.

Intake and exhaust valves: 0.05 mm (0.002 in.)

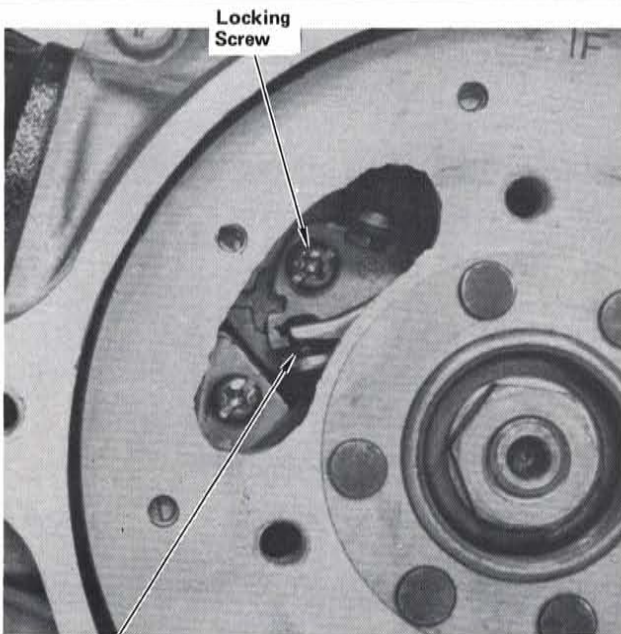

STEP 27—Check point gap. Adjust if necessary, as described in owner’s manual or shop manual.

Point gap: 0.3-0.4 mm (0.012-0.016 in.)

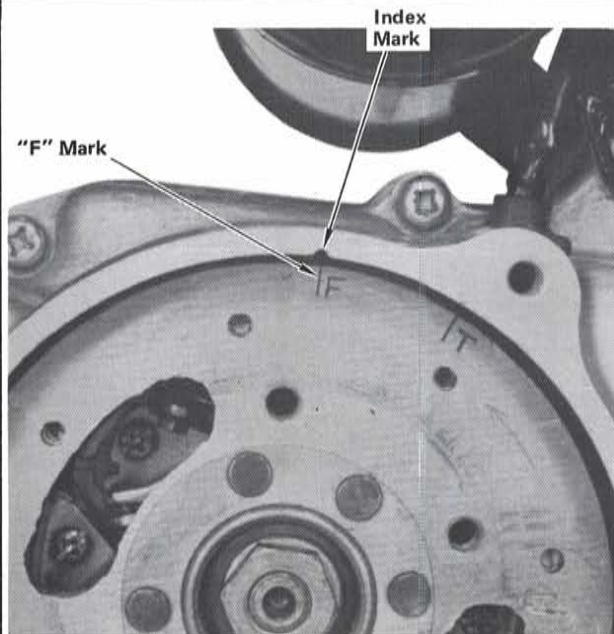

STEP 28—Turn flywheel counterclockwise to the “F” mark. Check that points are just beginning to open. Adjust if necessary, as described in owner’s manual.

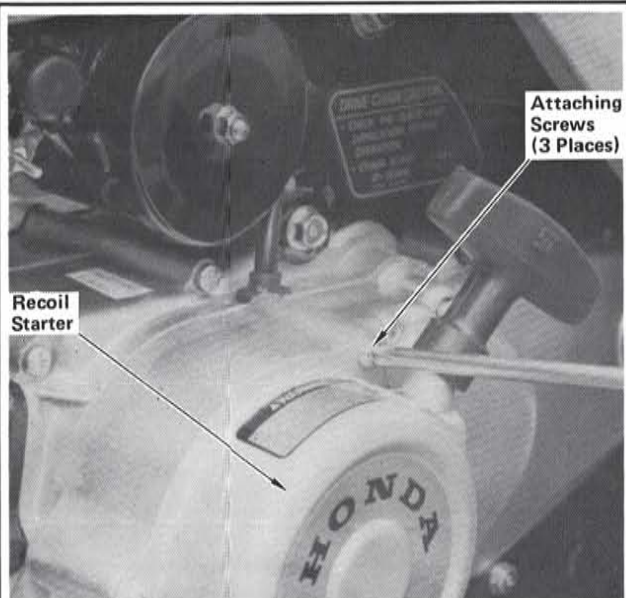

STEP 29— Reinstall starter pulley (four 6 mm hex bolts and lock washers) and recoil starter (three pan head screws). Tighten starter pulley bolts to specified torque. Tighten screws securely.

Torque specification:
1.0 kg-m (8 lb-ft)

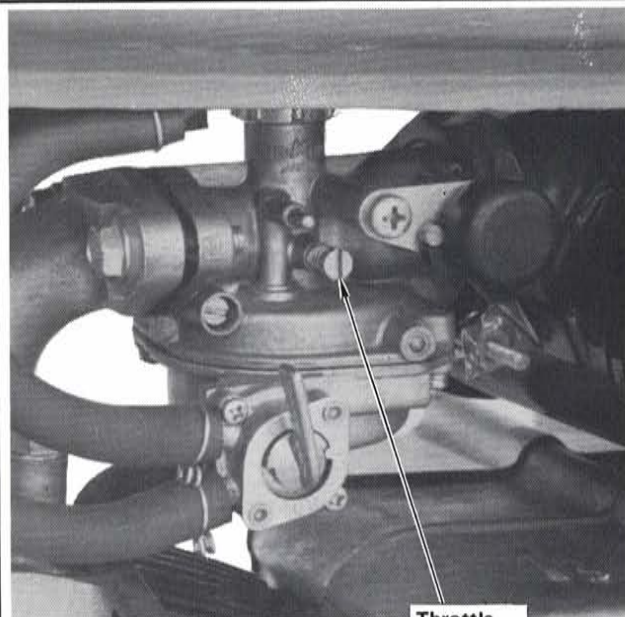

STEP 30— Adjust throttle stop screw and the throttle lever free play, if necessary, as described in owner's manual or shop manual. Refer to owner's manual for use of the speed limiter screw.

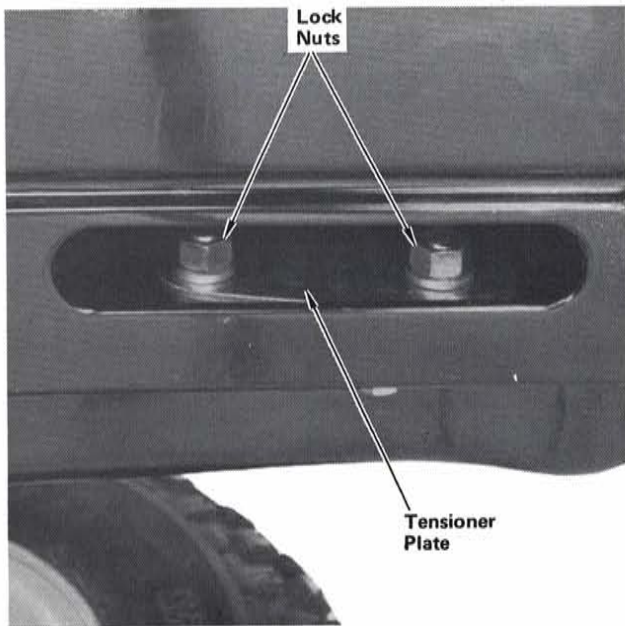
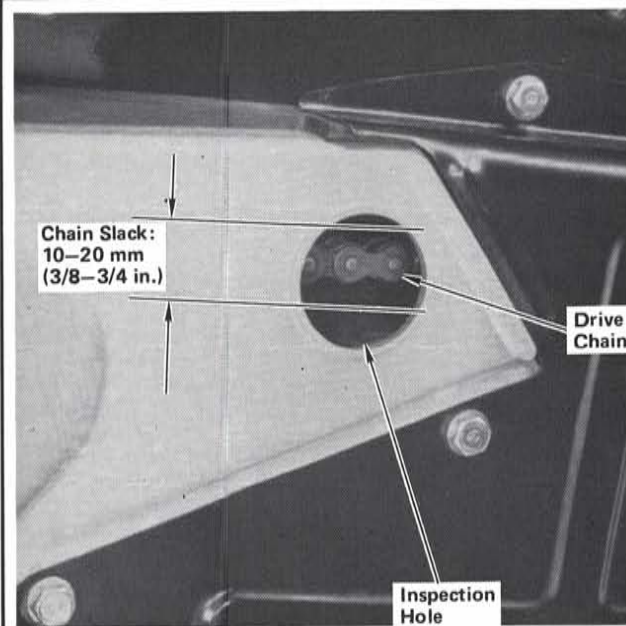

STEP 31— Remove drive chain inspection hole cover and check for a drive chain slack of 10-20 mm (3/8-3/4 in.). Adjust drive chain slack as follows, if necessary. Stop engine and position vehicle to obtain access to chain tensioner plate through hole in skid plate. Loosen the two lock nuts and move tensioner plate to obtain correct chain slack. Tighten both lock nuts securely. Lubricate drive chain using a commercially prepared chain lubricant, and reinstall inspection hole cover.

TORQUE TABLE

ITEM	SIZE	TORQUE
Front fork bolts	-----	4.5 kg-m (32 lb-ft)
Handlebar holder nuts	10 mm	4.5 kg-m (32 lb-ft)
Carrying handle bolts	8 x 16 mm	2.2 kg-m (16 lb-ft)
Rear wheel bolts	8 x 20 mm	2.2 kg-m (16 lb-ft)
Front axle nut	-----	7 kg-m (51 lb-ft)
Step guard bolts	8 x 25 mm	2.2 kg-m (16 lb-ft)
	10 x 16 mm	4.5 kg-m (32 lb-ft)
Recoil starter pulley bolts	6 mm	1.0 kg-m (8 lb-ft)

NOTE: Check all items listed on the following Pre-delivery Service Check List. Refer to owner's manual or shop manual for specifications and detailed procedures. Always test ride the unit to make sure that it is functioning properly.

PRE-DELIVERY SERVICE CHECK LIST

- | | |
|---|--|
| <ul style="list-style-type: none"> <input type="checkbox"/> Adjust rear brake, check cable routing and check operation. <input type="checkbox"/> Drain oil from crankcase (if necessary). Re-fill with recommended oil. <input type="checkbox"/> Inspect fuel tank, drain and flush, if necessary. <input type="checkbox"/> Check valve clearance; adjust if necessary. <input type="checkbox"/> Fill fuel tank, turn on petcock and check for leaks. <input type="checkbox"/> Clean and check contact points and ignition timing; and adjust if necessary. <input type="checkbox"/> Adjust idle speed. <input type="checkbox"/> Check throttle lever free play, cable routing, and operation in all steering positions. <input type="checkbox"/> Adjust and lubricate drive chain. <input type="checkbox"/> Check tire pressure. | <ul style="list-style-type: none"> <input type="checkbox"/> Inspect electrical component for proper operation. <ul style="list-style-type: none"> • Engine stop switch. <input type="checkbox"/> Check security of all nuts, bolts, and other fasteners. <input type="checkbox"/> Check to ensure all applicable recall and product update campaigns are complied with. <input type="checkbox"/> TEST RIDE: Check performance, handling, and operation. <ul style="list-style-type: none"> • Transmission and clutch: Ease of shifting, clutch operation, etc. • Acceleration: Smoothness, etc. • Cruising: Smoothness, etc. • Handling: Stability and cornering. • Brake: Smoothness and stopping power. • Idling: Smoothness, throttle response, return to idle. • Recheck idle speed after 10 minutes of stop and go operation. • Upon completion of test ride, check for fuel and oil leaks. |
|---|--|

LOOSE PARTS

The following is a list of loose parts contained in the crate:

DESCRIPTION	H/C	PART NUMBER
Rear brake lever	046510	53178-147-0000
Screw, rear brake lever pivot	016914	90114-063-0000
Nut, hex head, 5 mm	015688	94001-0500-0S
Washer, lock, 10 mm (2 reqd.)	033092	94111-10800
Nut, hex head, 10 mm (2 reqd.)	034137	94001-10080-0S
Step guard, right	067395	50620-957-0000
Step guard, left	067396	50630-957-0000
Bolt-washer, 10 x 16 mm (2 reqd.), step guard	067489	93492-10016-08
Bolt-washer, 8 x 25 mm (2 reqd.), step guard	067491	93493-08025-08
Front fender	067406	61100-957-000AZ
Bolt, tapping (4 reqd.), front fender	067420	90202-957-000
Washer, (4 reqd.), front fender	029937	64348-086-000
Pin, cotter, 3 x 25 mm, front axle nut	005842	94201-30250
Carrying handle	067411	81200-957-000
Bolt-washer, 8 x 16 mm (4 reqd.), carrying handle	067490	93493-08016-08
Bolt-washer, 8 x 20 mm (6 reqd.), rear wheel	067488	93492-08020-00
Front wheel	-----	4430Z-957-000
Rear wheel (2 reqd.)	-----	4230Z-957-000
Screw, speed limiter, 5 x 14 mm	017179	93500-05018-0A
Nut, hex head, 5 mm, speed limiter	015688	94001-05000-0S
Owner's manual (1979)	074539	3195702
Owner's manual (1980)	093854	3195703
Owner's manual (1981)	094853	3195704
Owner's manual (1982)	106995	3195705

(

(

(

(

(

(

(

(

(

(

(

(

(

(

READ THIS READ THIS READ THIS

HONDA

MODIFICATIONS WHICH YOU HAVE MADE, OR SHOULD MAKE IN THE FUTURE, TO ANY HONDA MOTORCYCLE, SHALL BE DEEMED BY OUR COMPANY TO HAVE BEEN PERFORMED AT YOUR SOLE RISK AND RESPONSIBILITY, AND WITHOUT OUR COMPANY'S OR THE MANUFACTURER'S APPROVAL OR CONSENT, IMPLIED OR EXPRESSED. WE FURTHER DISCLAIM ANY AND ALL LIABILITY, OBLIGATION, OR RESPONSIBILITY FOR ANY DEFECTS OF MODIFIED PARTS OR OF THE MODIFIED MOTORCYCLE, AND FOR ANY CLAIMS, DEMANDS, OR CAUSES OF ACTION FOR DAMAGE TO PROPERTY OR FOR PERSONAL INJURIES RESULTING FROM THE MODIFICATION OF SAID HONDA MOTORCYCLE.

READ THIS READ THIS READ THIS

READ THIS READ THIS READ THIS