

Set-up Instructions



MPD 6167 8308

AMERICAN HONDA MOTOR CO., INC.
100 WEST ALONDRA BOULEVARD, GARDENA, CALIFORNIA 90247

1984 Model ATC125M

WARNING**WARNING****WARNING****WARNING**

SET-UP AND PRE-DELIVERY SERVICE MUST BE PERFORMED BY AN AUTHORIZED HONDA MOTORCYCLE DEALER. Proper set-up and pre-delivery service is essential to rider safety and reliability of the ATC. When a customer takes delivery of his brand new ATC, he expects it to be in excellent running condition. There are few things that will cause greater customer dissatisfaction than poor preparation of a new unit. An error or oversight made by the mechanic assembling and servicing a new unit can easily result in faulty operation, damage to the machine, or even injury to the rider.



NOTE: Right and left are determined from the rider's view.

Date of Issue: 8/83

SET-UP INSTRUCTION REVISED PAGES

Pages Affected

1 through 25

Orig. Issue Date

8/83

Rev. Date

Original

Remove and destroy superseded pages.

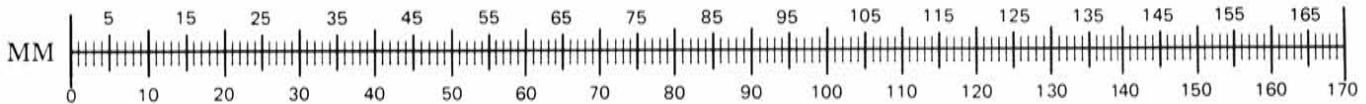

METRIC SCALE FOR DETERMINING BOLT LENGTHS/DIAMETERS

Pay special attention to warnings, cautions, and notes.

WARNING means hazards or unsafe practices which could cause severe personal injury or death.

CAUTION: means hazards or unsafe practices which could cause minor personal injury or product or property damage.

NOTE: gives helpful information.

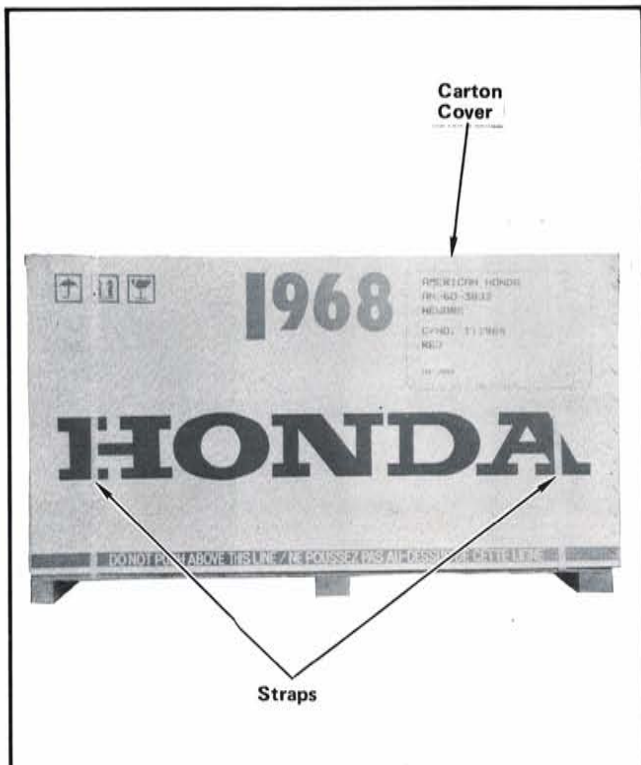

STEP 1—Cut straps and remove carton cover by lifting it up.

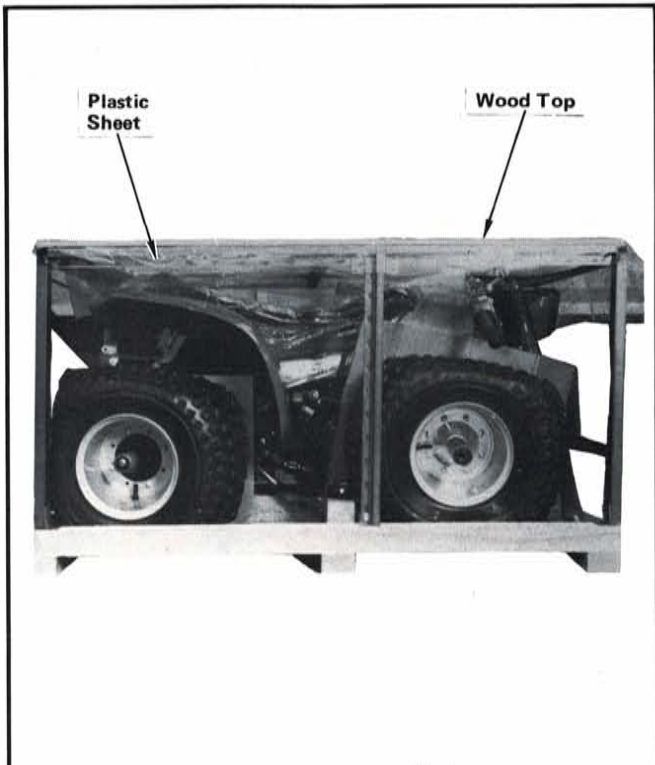

STEP 2—Remove crate wood top and plastic sheet.

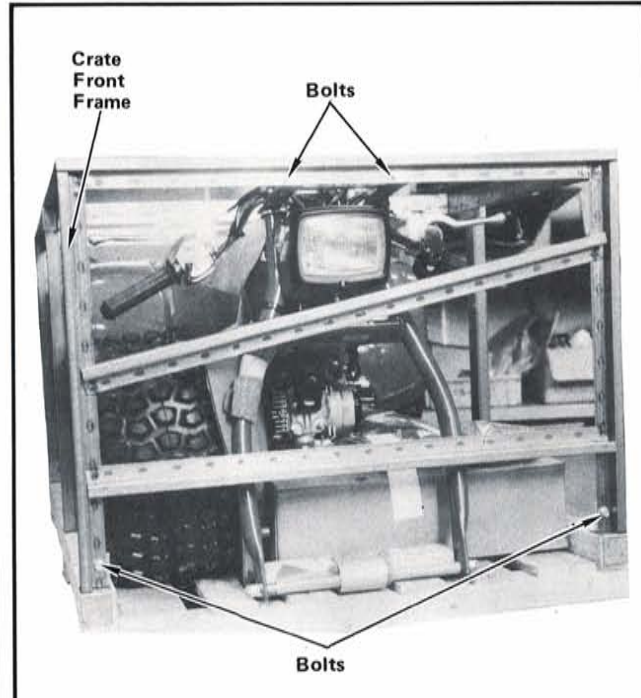

STEP 3—Remove two bolts attaching crate front frame to front shipping bracket. Remove two bolts attaching crate front frame to crate base. Discard bolts.

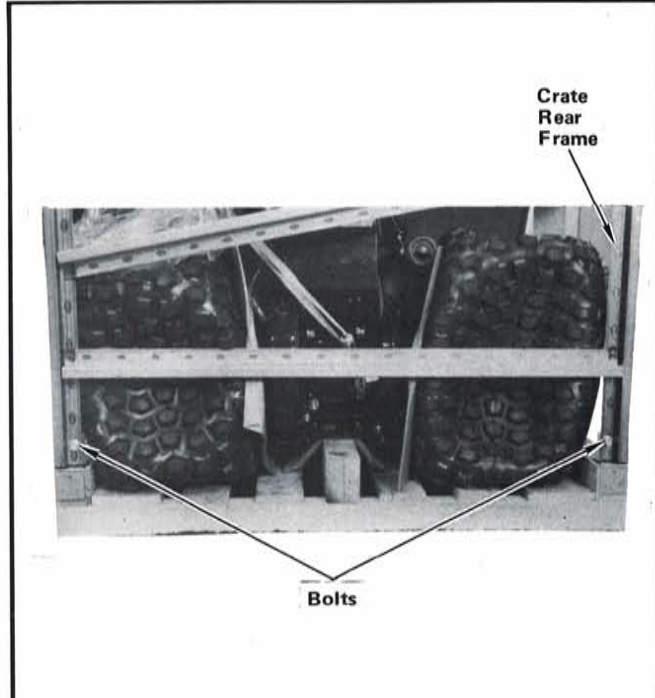

STEP 4—Remove two bolts attaching crate rear frame to crate base.

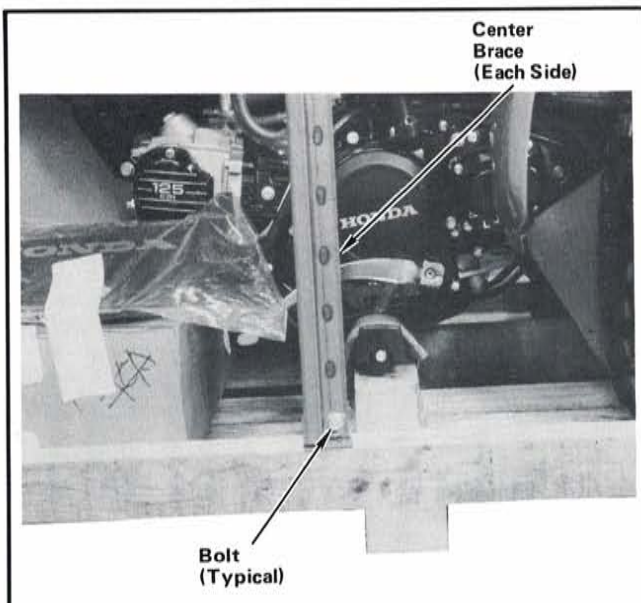

STEP 5—Remove bolts attaching center braces to crate base. Carefully lift off crate frame using two people. Discard bolts and crate frame.

CAUTION: Use extreme care not to damage ATC with crate frame.

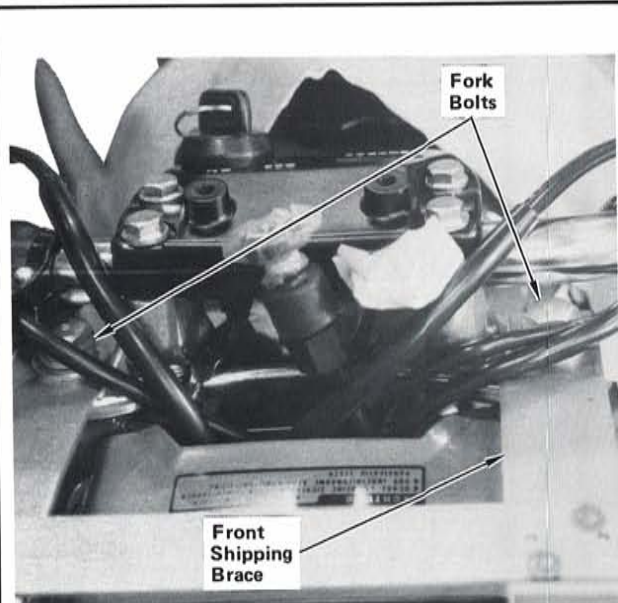

STEP 6—Loosen fork bolts and remove front shipping brace. Retighten fork bolts to specified torque. Discard shipping brace.

Torque specification:
6 kg-m (44 lb-ft)

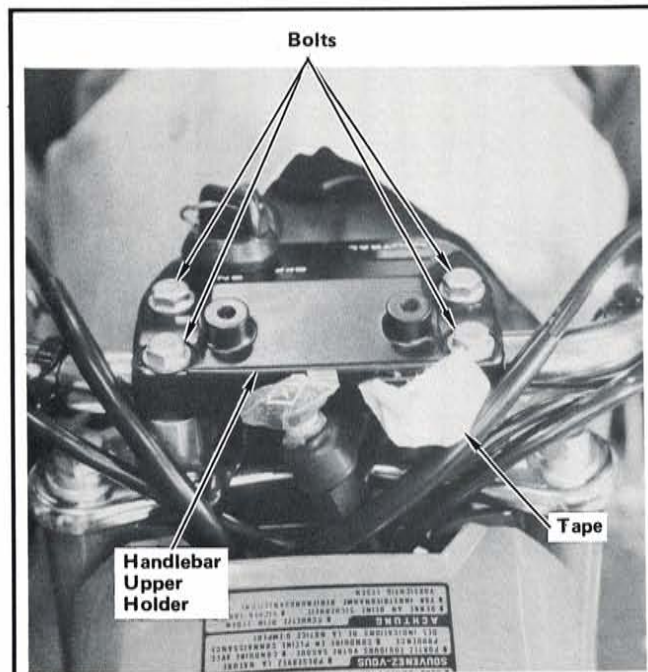

STEP 7—Loosen four bolts attaching upper handlebar holder. Remove protective tape from choke knob bracket.

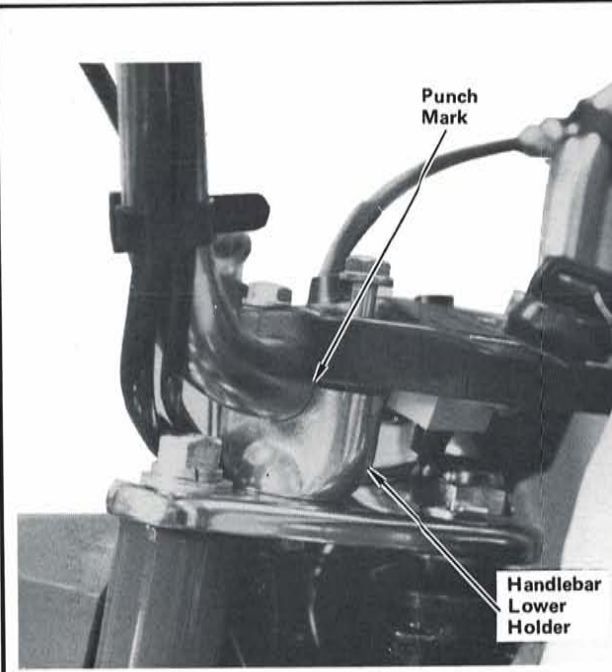

STEP 8—Raise handlebar grips until punch mark on handlebar is aligned with top of lower holder and serrations are aligned with lower holders.

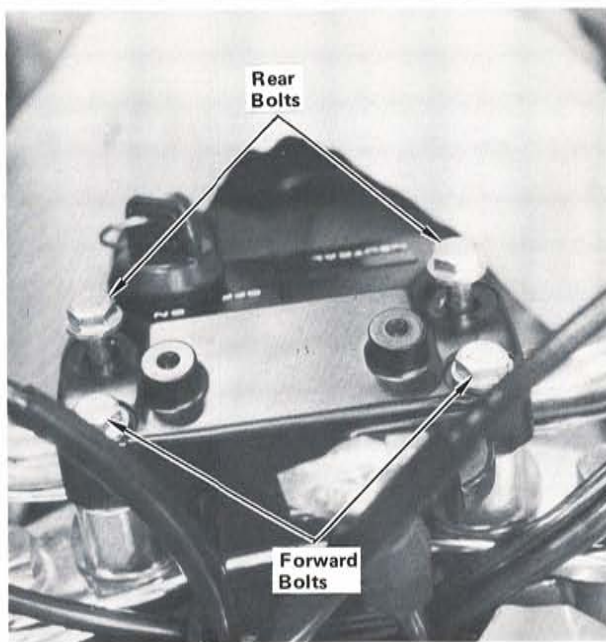

STEP 9—Tighten forward bolts to specified torque first, then tighten rear bolts to same torque.

Torque specification:
2.4 kg-m (18 lb-ft)

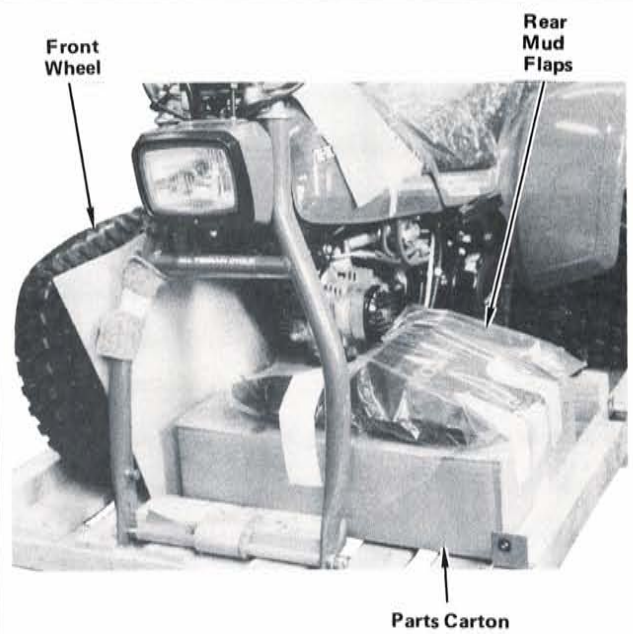

STEP 10—Remove front wheel, parts carton, and rear mud flaps from crate base.

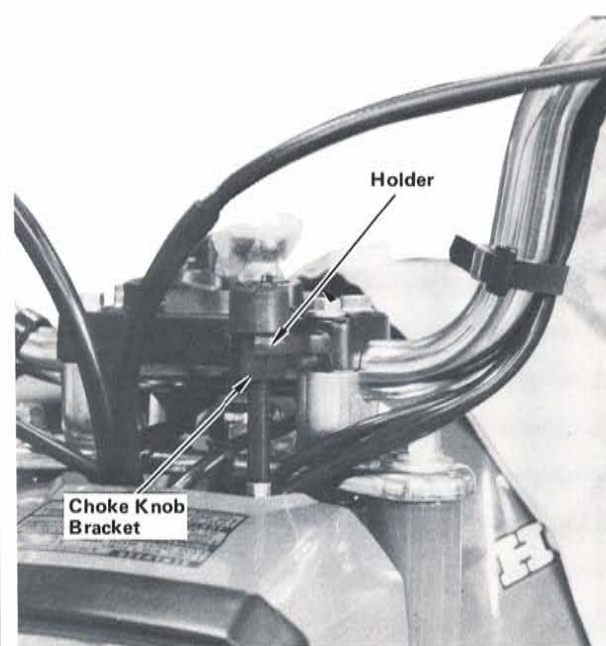

STEP 11—Insert choke knob bracket into holder, with flat on bracket aligned with flat on holder. Tighten retaining nut securely.

CAUTION: Do not overtighten retaining nut.



STEP 12—Press emblem out of handlebar cover.

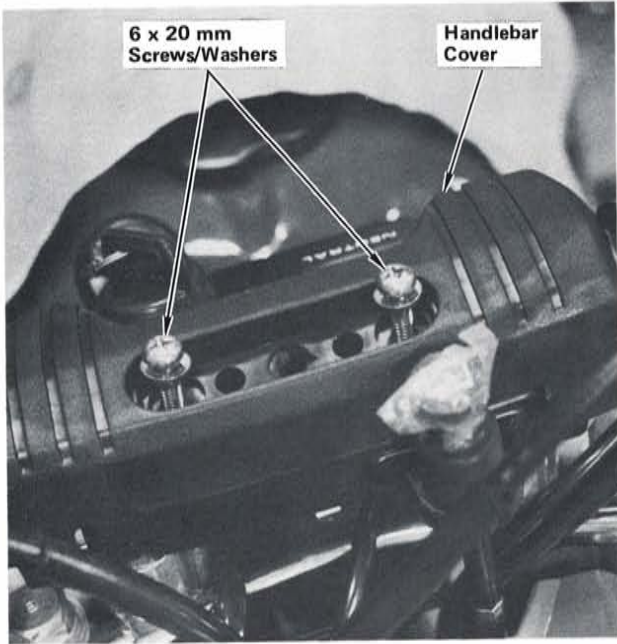

STEP 13—Position handlebar cover over handlebar upper holder as shown and install using two 6 x 20 mm screws/washers. Tighten screws securely and reinstall emblem as shown.

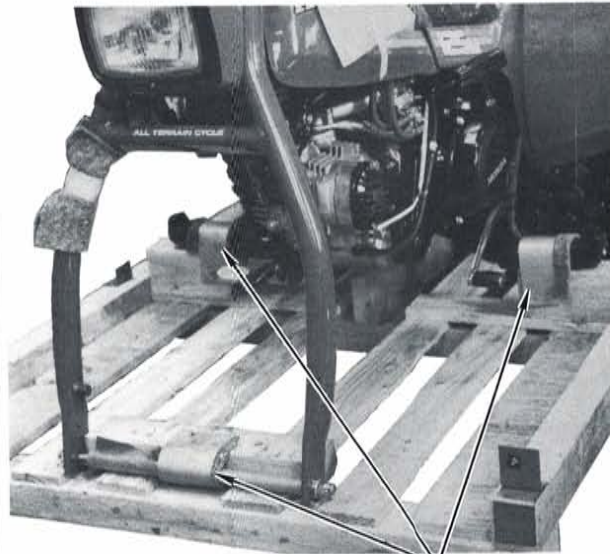

STEP 14—Remove straps holding front axle and foot pegs to crate base by removing nails.

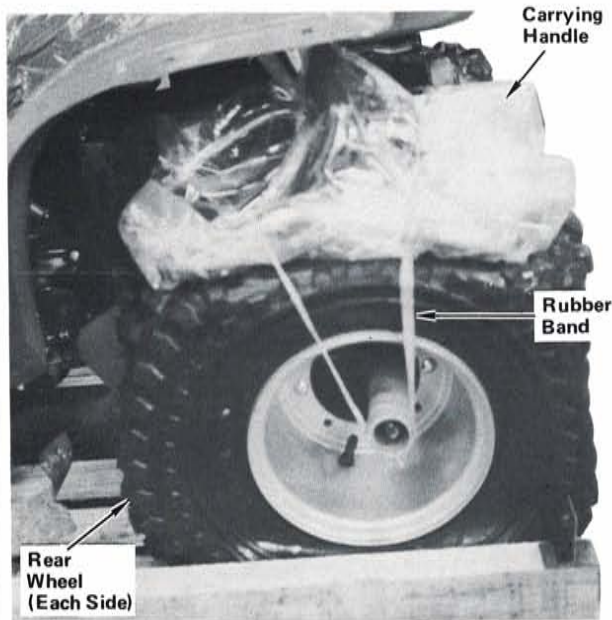

STEP 15—Remove rear carrying handle by removing rubber band. Raise rear of ATC up and remove rear wheels.

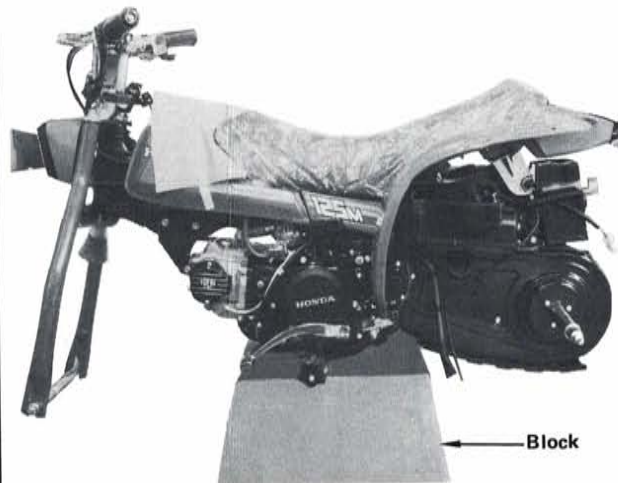

STEP 16—Place ATC on a padded block centered under engine as shown.

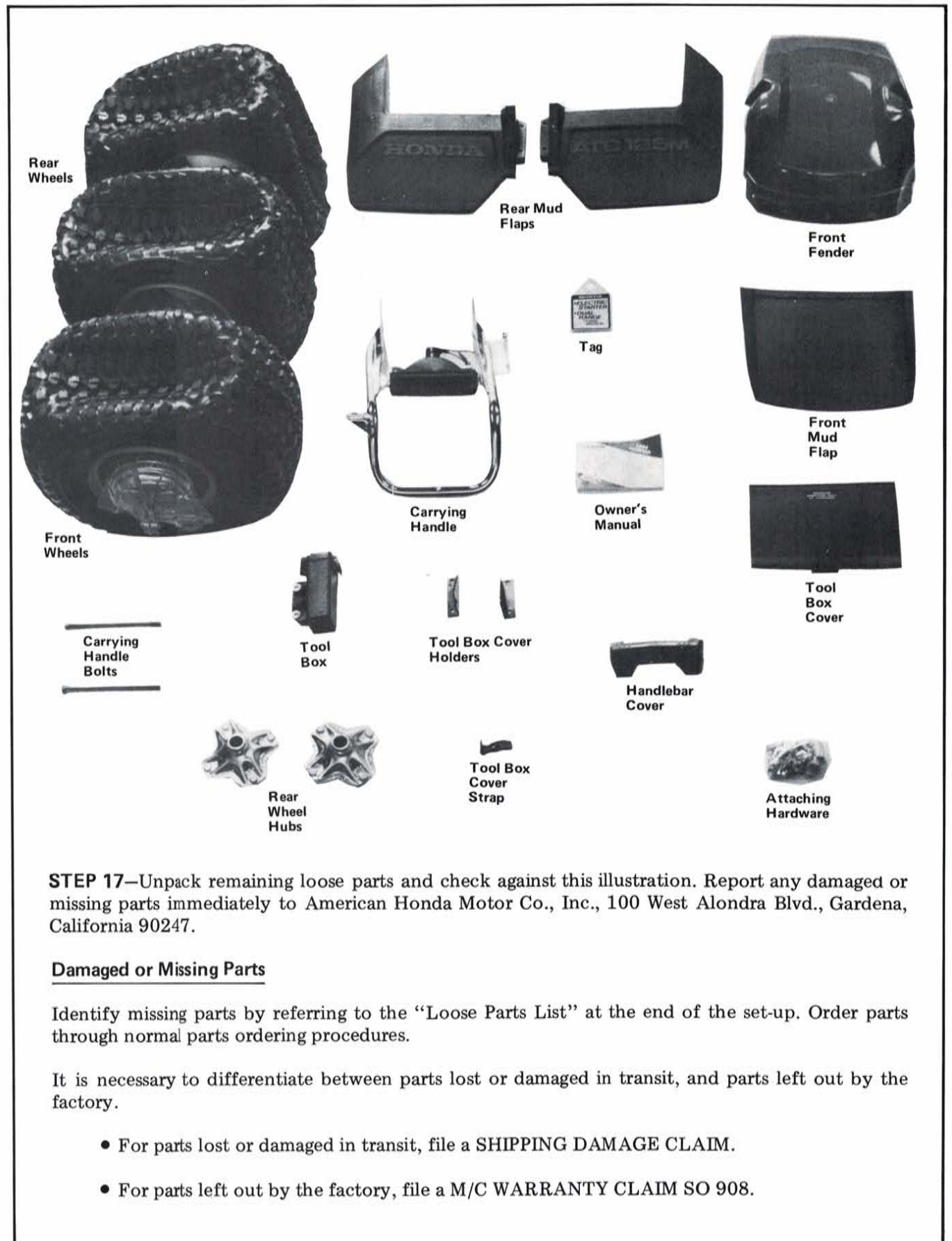

STEP 17—Unpack remaining loose parts and check against this illustration. Report any damaged or missing parts immediately to American Honda Motor Co., Inc., 100 West Alondra Blvd., Gardena, California 90247.

Damaged or Missing Parts

Identify missing parts by referring to the "Loose Parts List" at the end of the set-up. Order parts through normal parts ordering procedures.

It is necessary to differentiate between parts lost or damaged in transit, and parts left out by the factory.

- For parts lost or damaged in transit, file a SHIPPING DAMAGE CLAIM.
- For parts left out by the factory, file a M/C WARRANTY CLAIM SO 908.

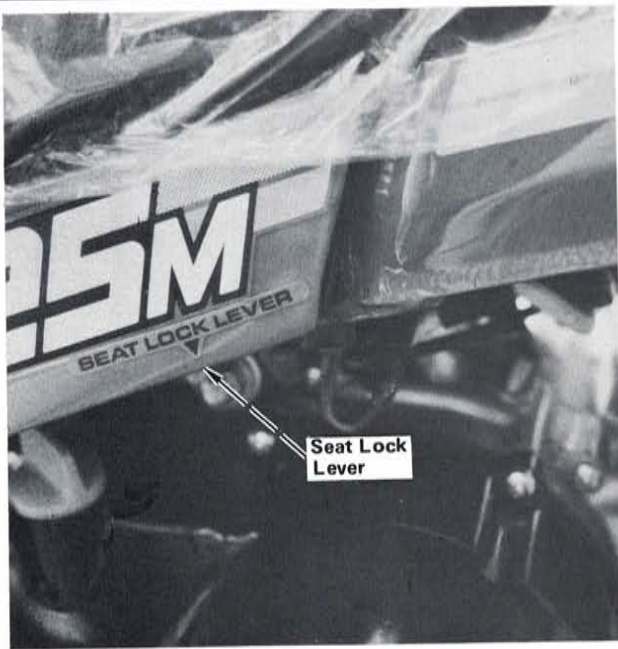

STEP 18—Remove fender/seat by pulling seat lock lever towards the rear.

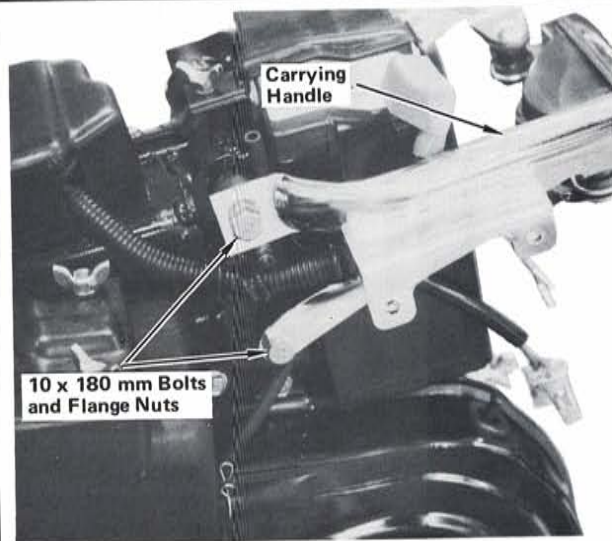

STEP 19—Position carrying handle with curve up as shown and install using two 10 x 180 mm bolts inserted from right side, with flange nuts on left. Tighten nuts to specified torque.

CAUTION: Check that taillight wires are not pinched between handle and frame.

Torque specification:
4.4 kg-m (32 lb-ft)

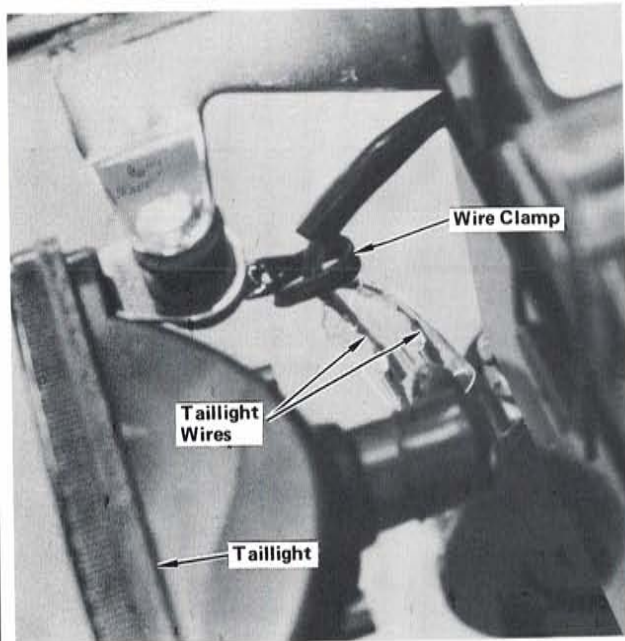

STEP 20—Connect taillight wires to wire harness color-to-color. Secure wires to left taillight mount as shown using wire clamp provided.

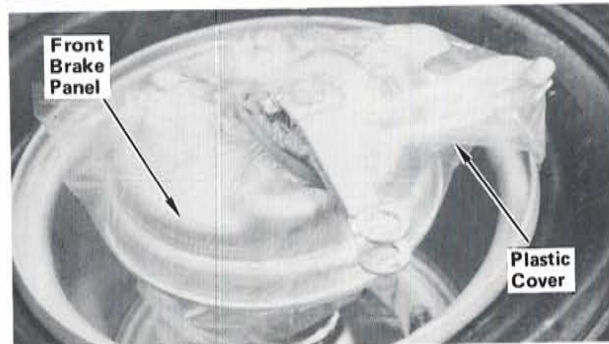
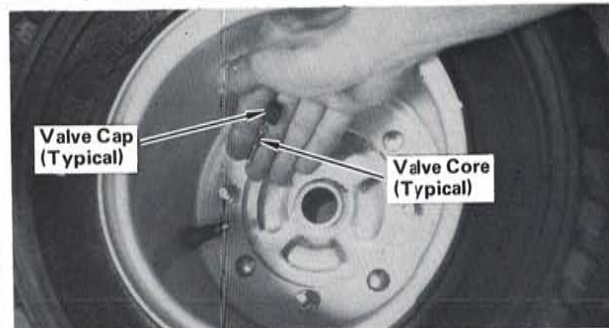

STEP 21—Remove valve cap from each tire and tighten valve core. Inflate all tires to 2.2 psi. and reinstall valve caps. Remove and discard plastic cover over front brake panel.



STEP 22—Insert studs of rear wheel hubs through rear wheels from side opposite valve stem.

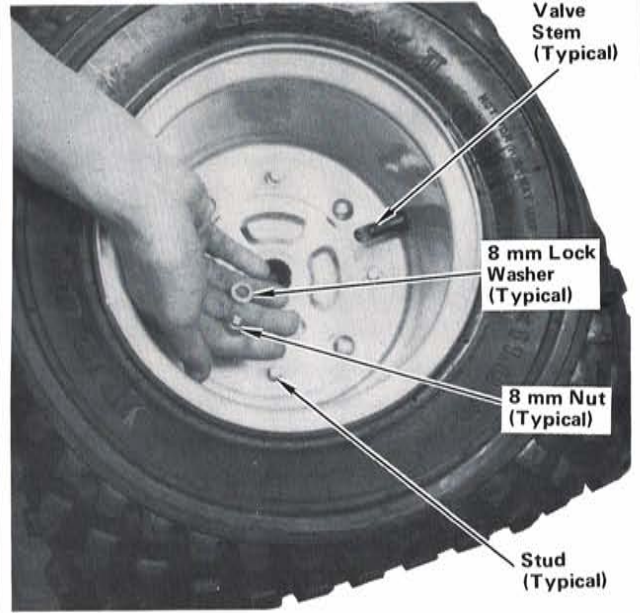

STEP 23—Install each rear wheel hub using four 8 mm lock washers and nuts on side of wheel having valve stem. Repeat step for other wheel. Tighten nuts to specified torque.

Torque specification:
2.2 kg-m (16 lb-ft)

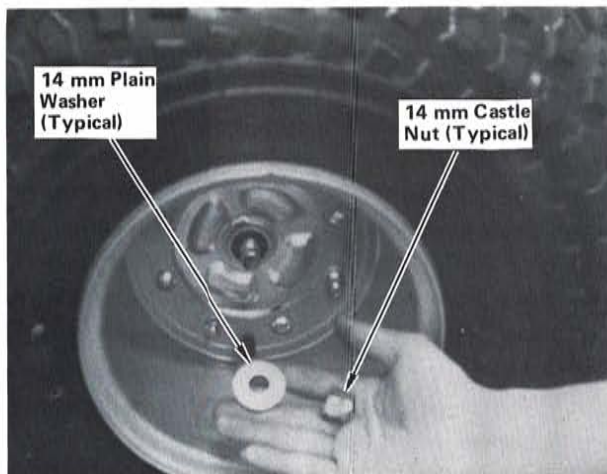

STEP 24—Grease rear axle splines and install rear wheels, with valve stems to the outside, using a 14 mm plain washer and castle nut for each.

NOTES:

- Install rear wheels so tire tread directional pattern will be same as front tire.
- Install 14 mm plain washers with "OUT-SIDE" marking facing out.

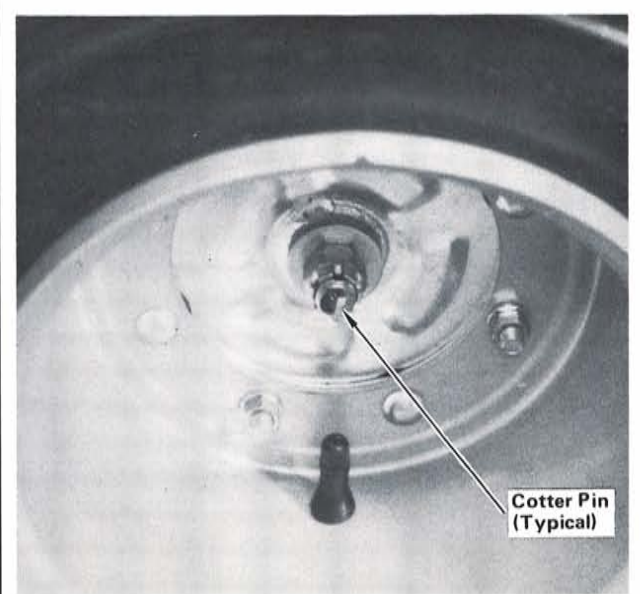

STEP 25—Tighten both rear axle nuts to specified torque and install a cotter pin in each. Spread ends of cotter pin as shown.

Torque specification:
7.0 kg-m (51 lb-ft)

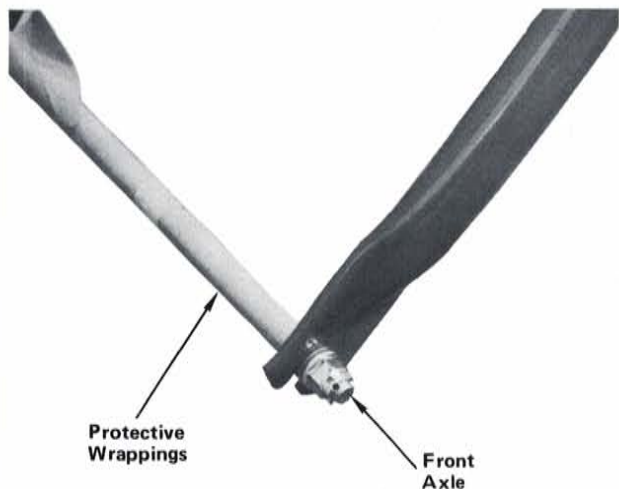

STEP 26—Remove front axle from fork legs. Remove protective wrappings from front axle and right fork leg.

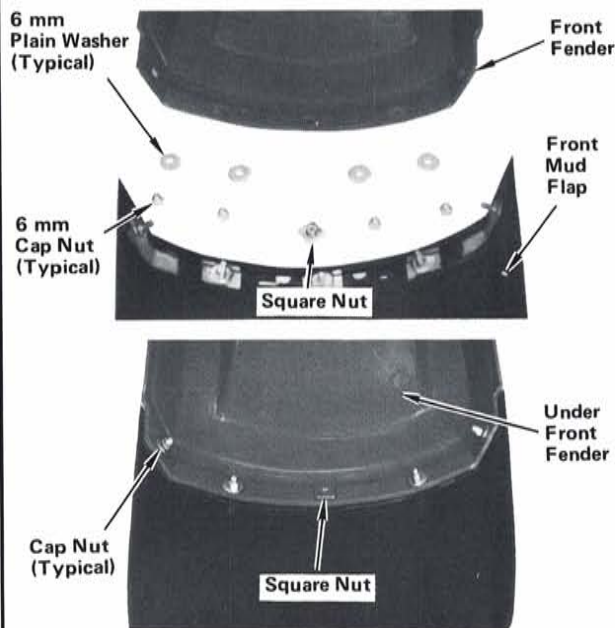

STEP 27—Install front fender mud flap using four 6 mm plain washers, cap nuts and a square nut. Tighten nuts to specified torque.

Torque specification:
0.8 kg-m (6 lb-ft)

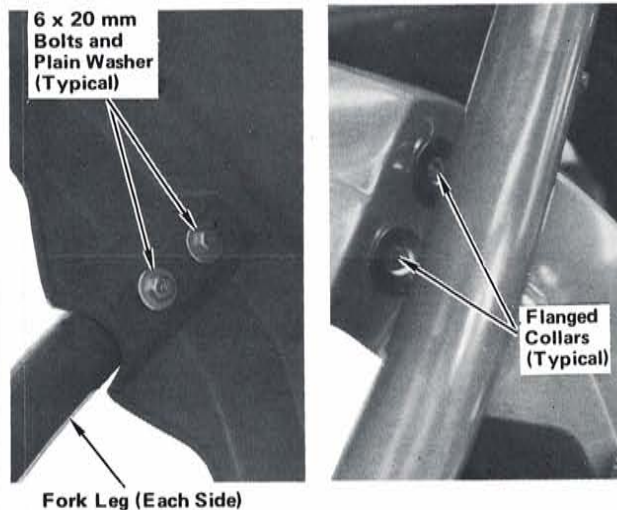

STEP 28—Position front fender between fork legs as shown and install using four 6 x 20 mm bolts, flanged collars, and plain washers as shown. Tighten bolts to specified torque.

Torque specification:
1.0 kg-m (8 lb-ft)

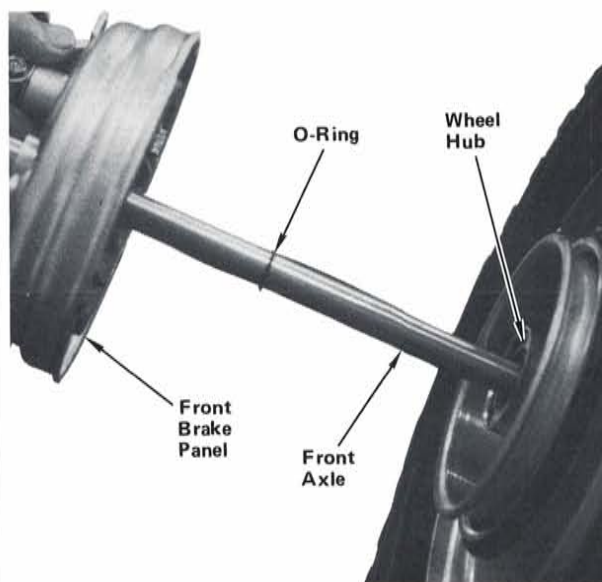

STEP 29—Remove brake panel from front wheel hub. Check that grease seal in wheel hub is clean and full of grease. Insert front axle through brake panel and slip an O-ring over end of axle. Push front axle through grease seals in wheel hub.

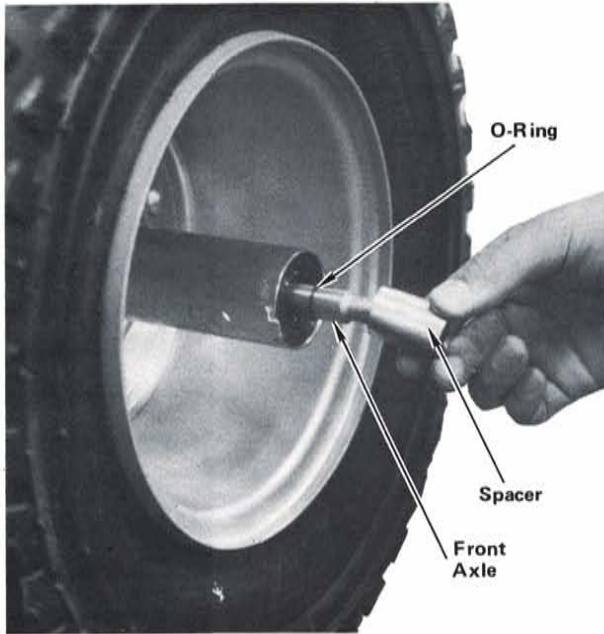

STEP 30—Slip an O-ring and spacer over end of front axle as shown.

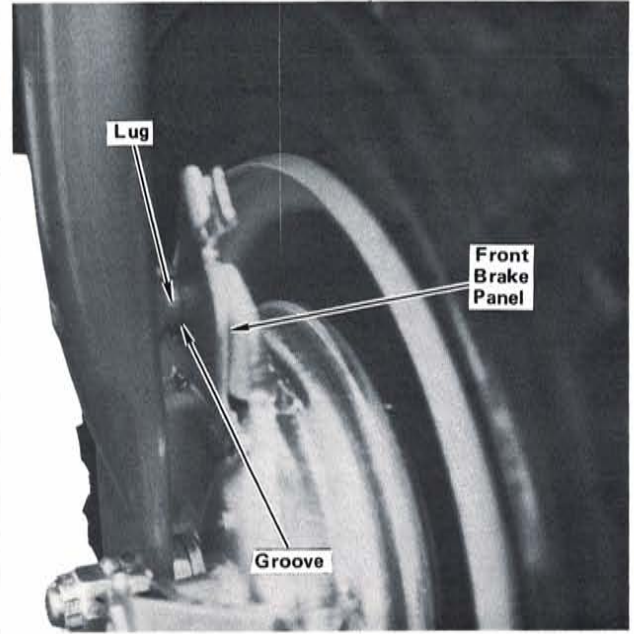

STEP 31—Position front wheel between fork legs, with front brake panel on right side, and align lug on right fork leg with groove in brake panel.

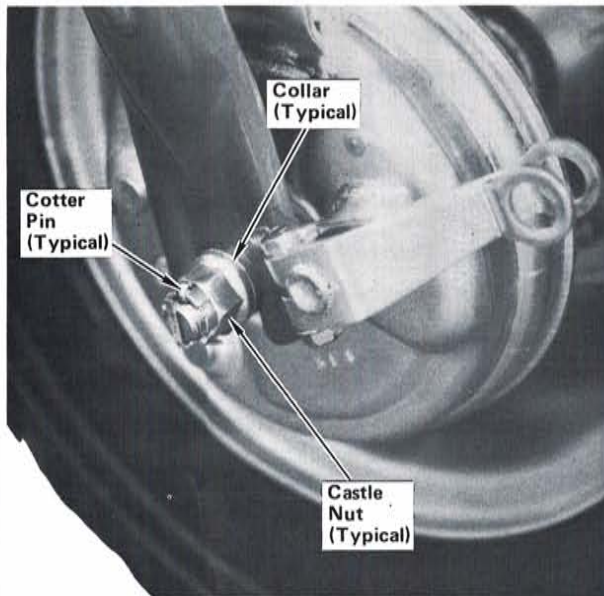

STEP 32—Install front wheel, using two collars and castle nuts. Tighten both axle nuts to specified torque and install a cotter pin in each. Spread ends of cotter pins as shown.

Torque specification:
6.0 kg-m (43 lb-ft)

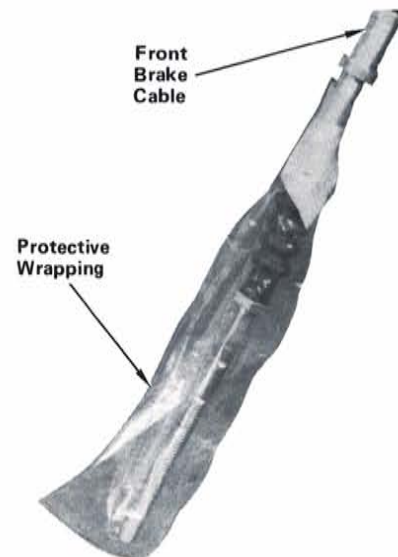

STEP 33—Remove protective wrapping from front brake cable.

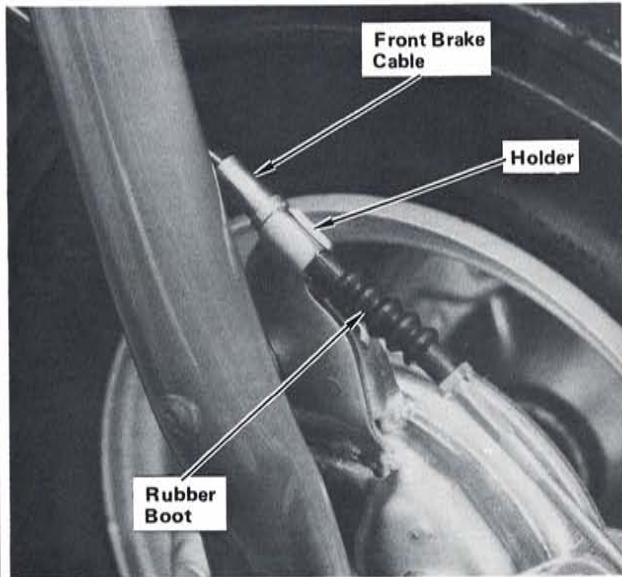

STEP 34—Insert front brake cable into holder on brake panel. Slip rubber boot over cable housing as shown.

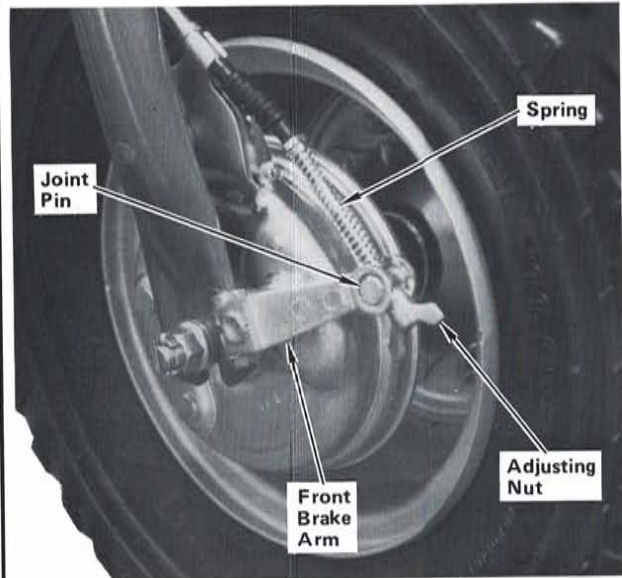

STEP 35—Insert a brake arm joint pin into hole in brake arm and slip a brake return spring over end of brake cable. Insert end of brake cable through joint pin and install cable adjusting nut. Adjust front and rear brakes as described in Steps 46, 47, and 48.

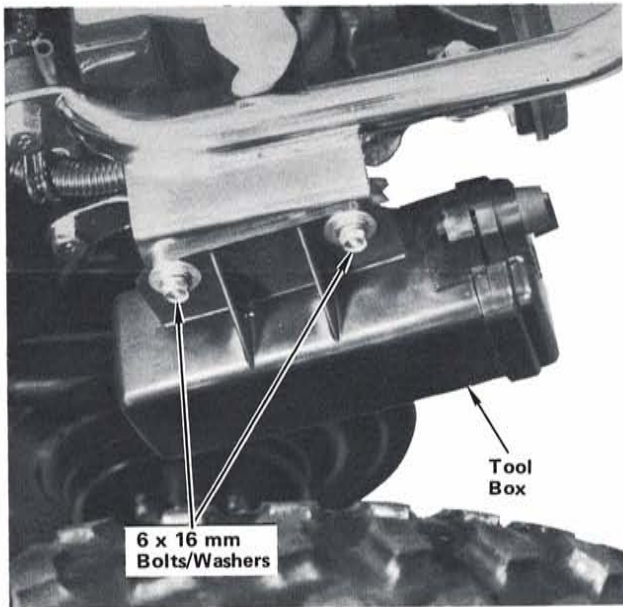

STEP 36—Position tool box on rear carrying handle as shown and install using two 6 x 16 mm bolts/washers. Tighten bolts securely.

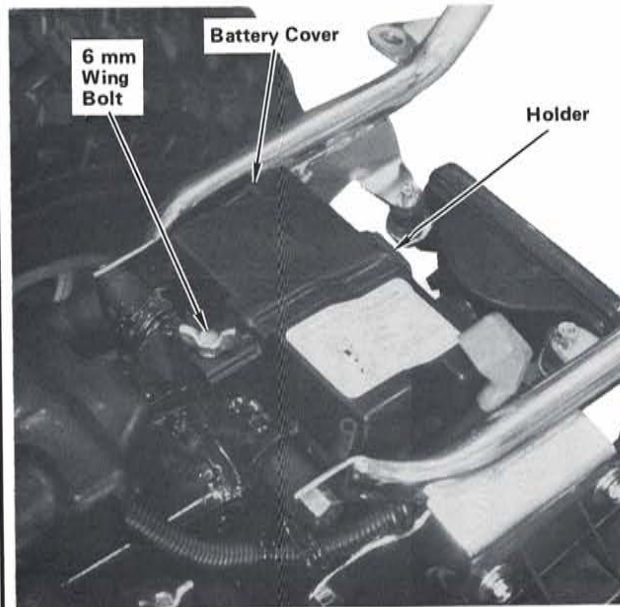

STEP 37—Remove battery cover and holder by removing a 6 mm wing bolt. Remove battery from battery compartment and service as described in shop manual or battery preparation booklet packed with battery.

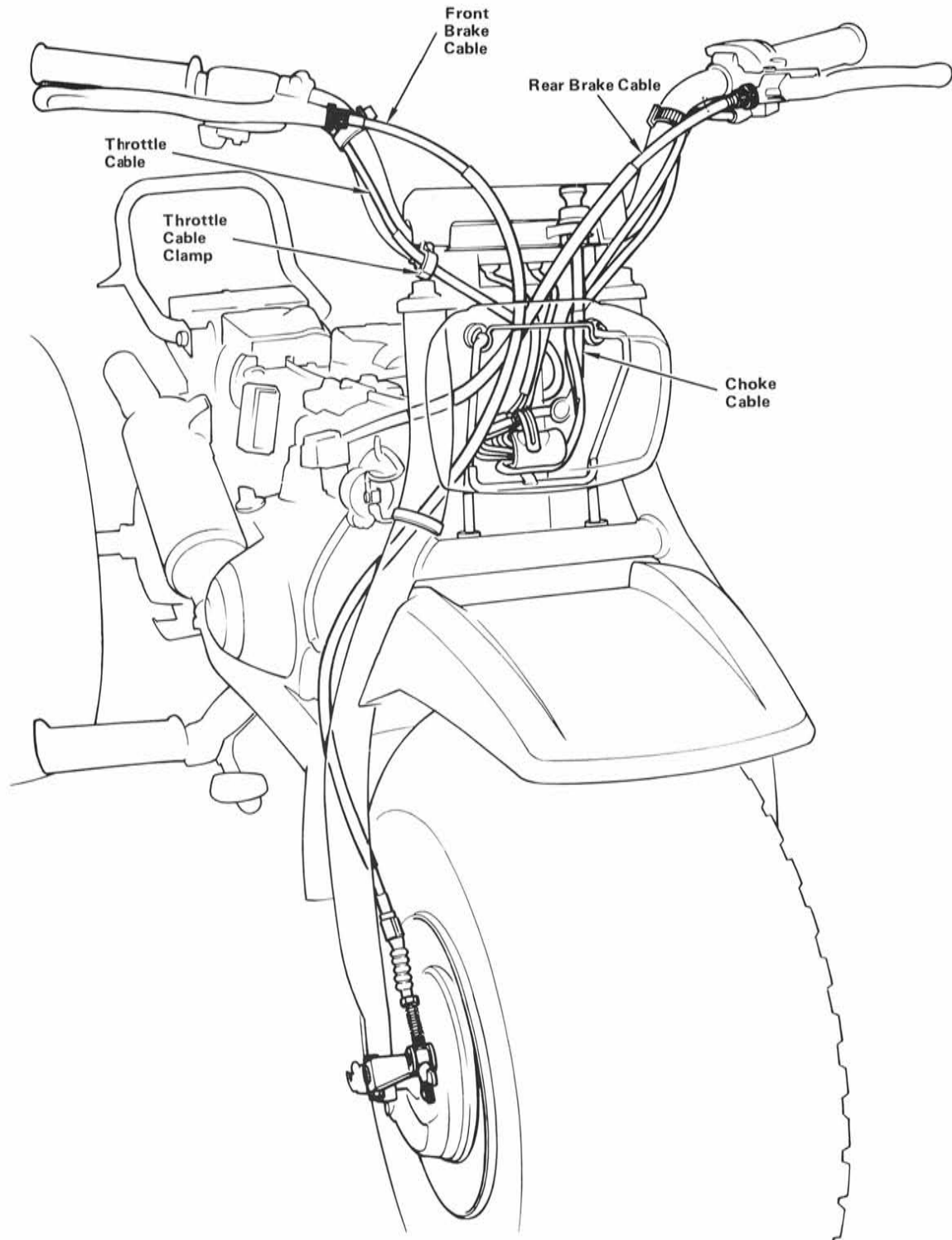

STEP 38—Check routing of front brake cable, throttle cable, engine stop switch wire, headlight switch wire, and wire harness as shown.

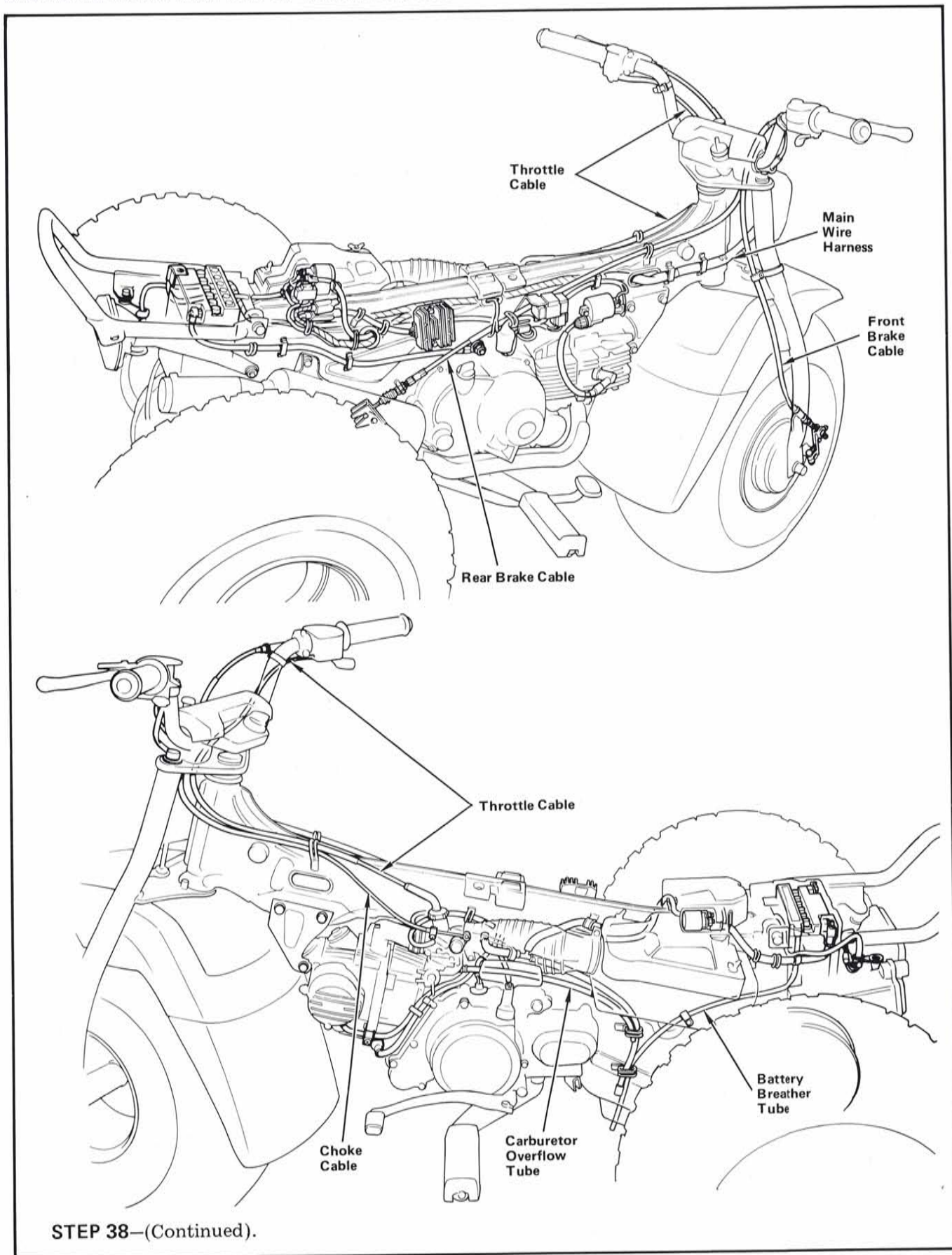

STEP 38—(Continued).

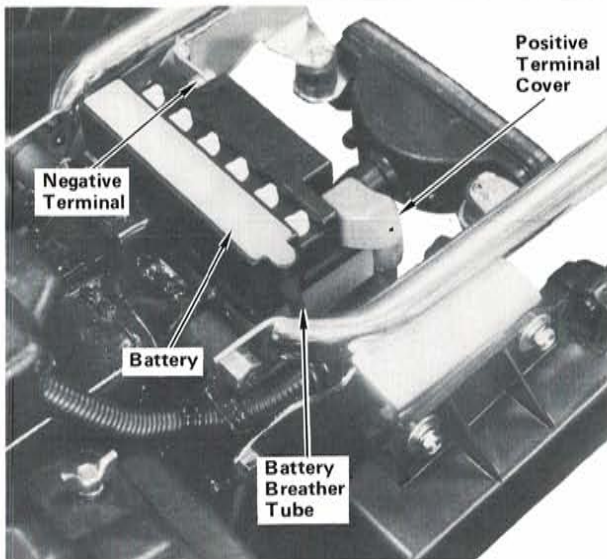

STEP 39—Install battery in battery compartment. Connect battery breather tube to battery breather elbow. Connect positive (+) battery cable to battery terminal first, then connect negative (-) battery cable. Tighten screws securely and coat battery terminals with clean grease. Slip terminal cover over battery positive terminal as shown.

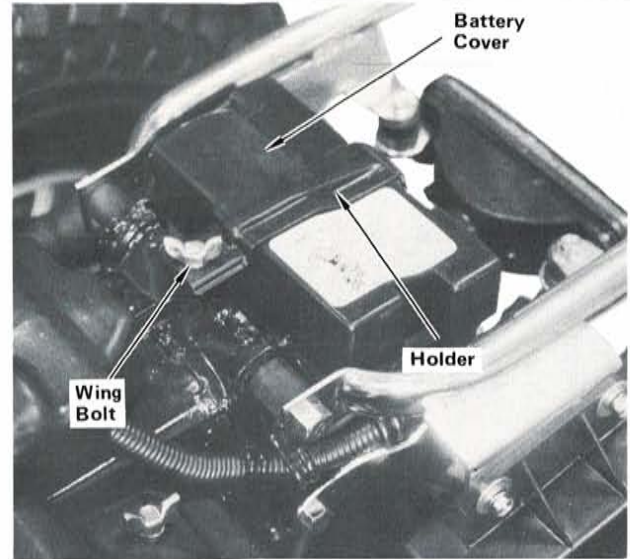

STEP 40—Reinstall battery cover and holder as shown, using 6 mm wing bolt removed in Step 37. Tighten wing bolt securely.

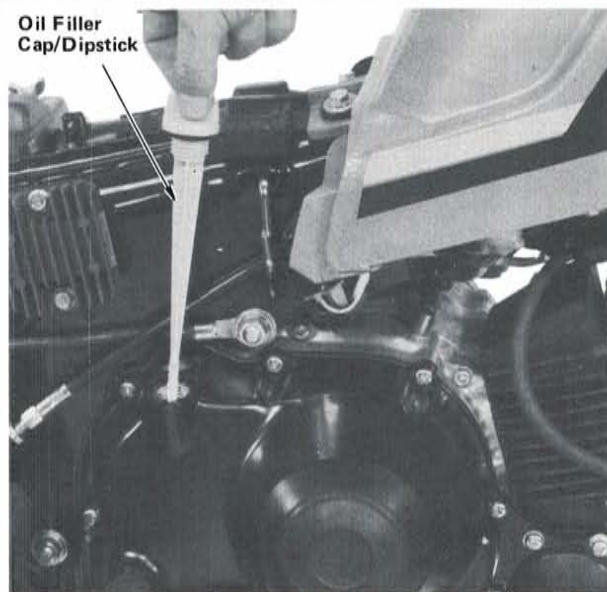

STEP 41—Remove oil filler cap/dipstick and fill crankcase with recommended oil as described in owner's manual. Reinstall and tighten cap.

NOTE: Do not drain oil until break-in period has been completed.

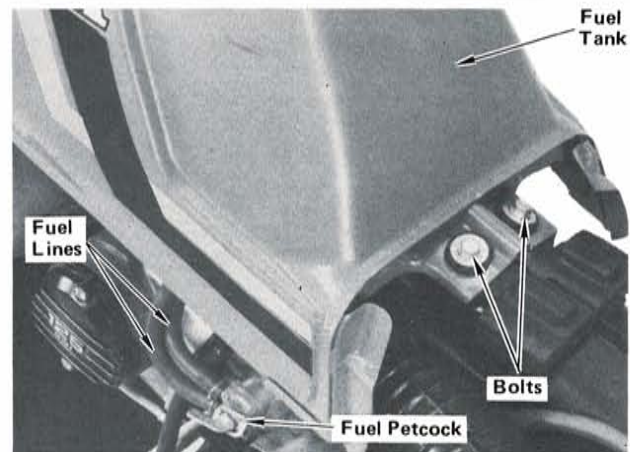

STEP 42—Drain fuel tank as described in owner's manual. Remove fuel tank by disconnecting fuel lines and removing two bolts at rear of the tank. Inspect and flush tank. Reinstall fuel tank using the two bolts removed, and reconnect fuel lines. Tighten bolts securely. Drain residual fuel from carburetor.

WARNING Fuel must be drained into a proper container. Gasoline is flammable and explosive under certain conditions. Do not smoke or allow flames or sparks near while draining fuel.

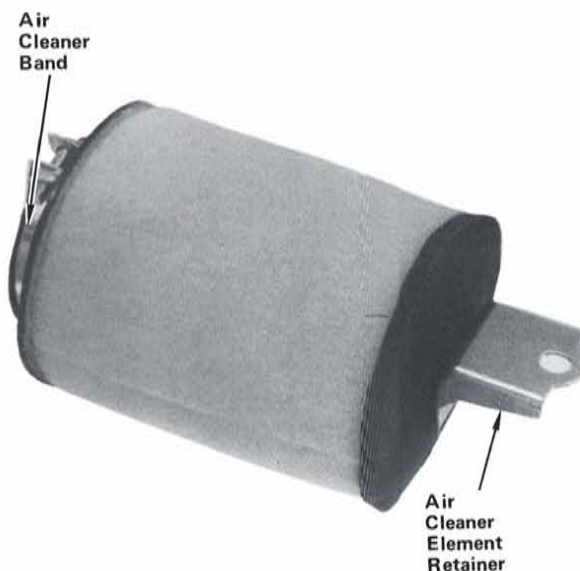
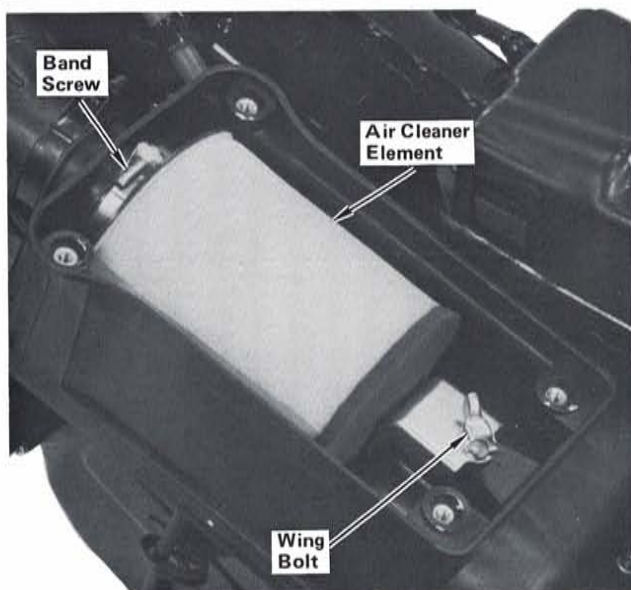

STEP 43—Remove wing bolts attaching air cleaner cover and retainer. Loosen air cleaner band screw. Remove air cleaner element assembly from air cleaner case. Remove retainer from air cleaner core and remove air cleaner element. Check condition of element. If necessary, clean element as described in owner's manual or shop manual. Reinstall element, retainer, and assembly into air cleaner case. Tighten air cleaner band screw. Reinstall air cleaner cover and tighten wing bolts securely.

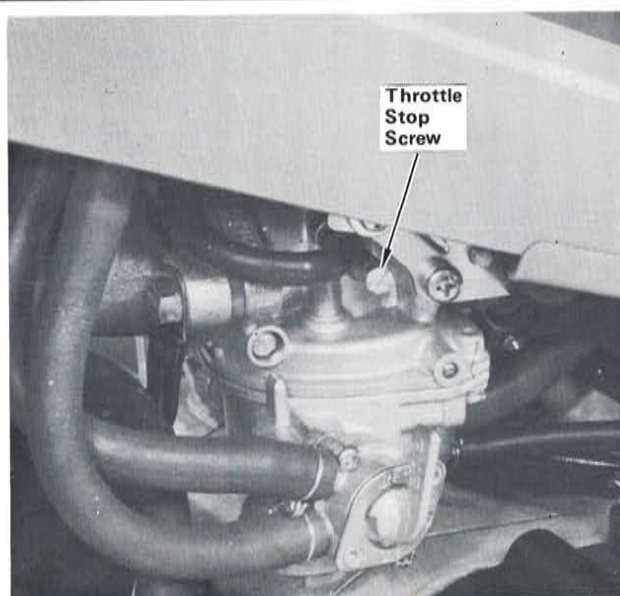

STEP 44—Connect a tachometer. Start engine and warm it up to operating temperature. Adjust idle speed to 1,700 rpm using throttle stop screw. Stop engine and disconnect the tachometer.

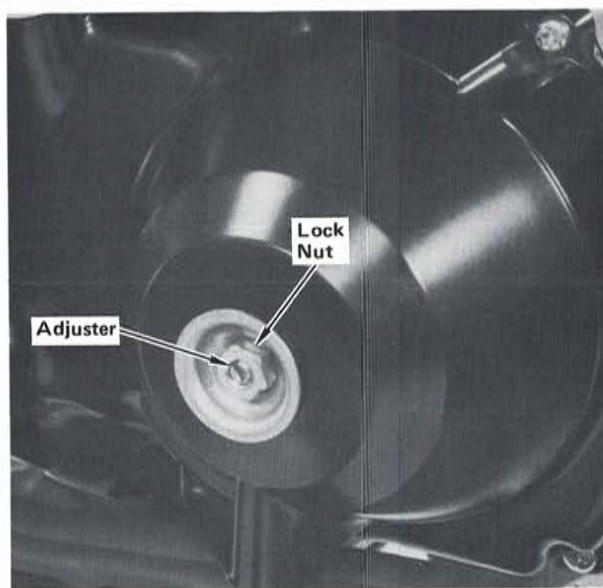

STEP 45—Check clutch operation. If adjustment is necessary, use the following procedure. Remove rubber cap. Loosen lock nut and turn clutch adjuster counterclockwise until resistance is felt, then turn clutch adjuster 1/8 turn clockwise and tighten lock nut. Recheck clutch operation. Reinstall rubber cap.

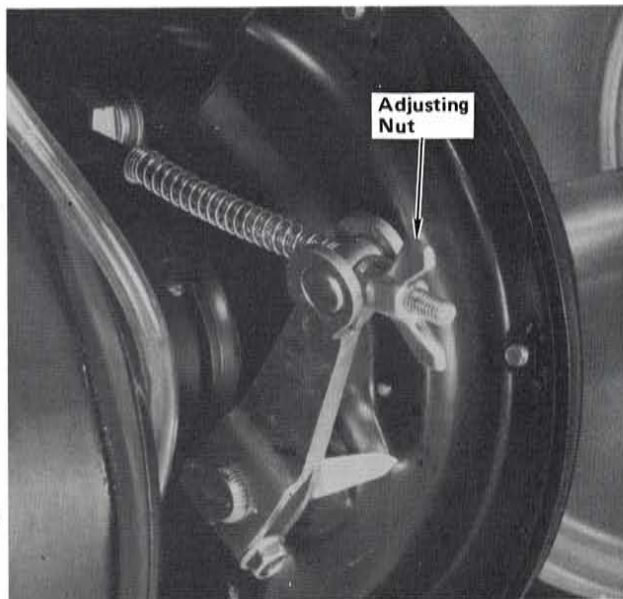
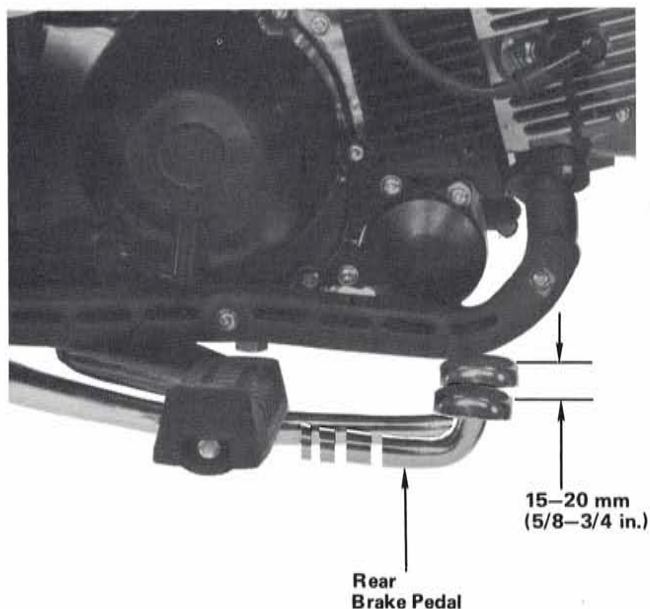

STEP 46—Check brake pedal free play. If adjustment is necessary, turn adjusting nut on brake rod at rear of frame.

Free Play: 15-20 mm (5/8-3/4 in.)

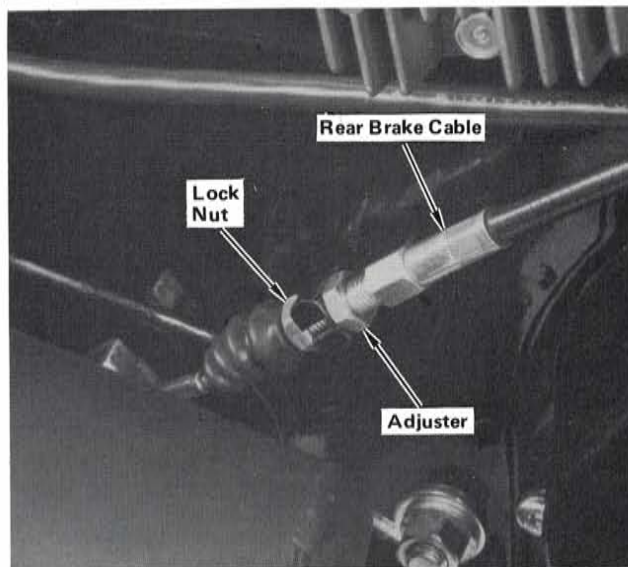
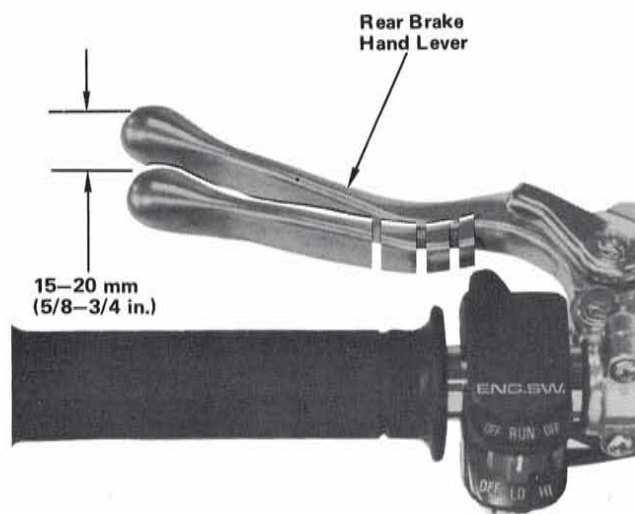

STEP 47—Place a block under ATC. Spin rear wheels by hand and measure free play of rear brake hand lever before brake starts to engage. Free play, measured at tip of rear brake hand lever should be between 15 and 20 mm (5/8-3/4 in.). Use adjusting nuts on rear brake arm to make large adjustments. Small adjustments are made at rear brake hand lever by loosening knurled nut and turning cable adjuster. After adjustment, tighten knurled nut. Remove block from under ATC.

Free Play: 15-20 mm (5/8-3/4 in.)

NOTE: Adjust brake pedal free play before adjusting rear brake hand lever free play.

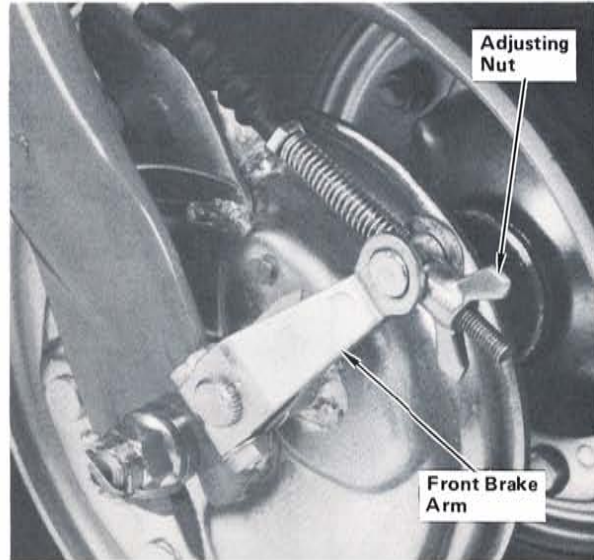
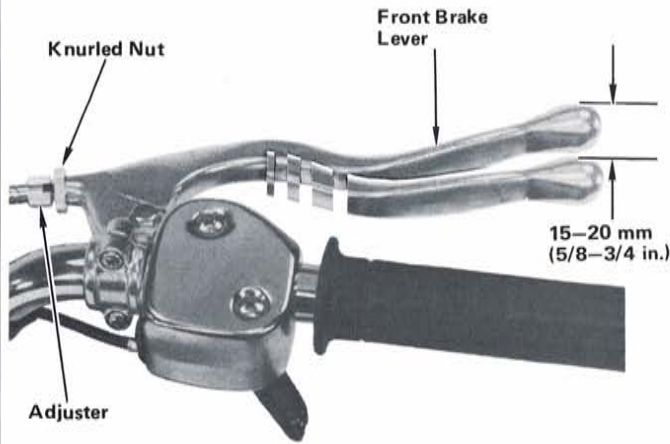

STEP 48—Place a block under ATC. Spin front wheel by hand and measure free play of front brake lever before brake starts to engage. Free play, measured at tip of brake lever should be between 15 and 20 mm (5/8–3/4 in.). Use adjusting nut on front brake arm to make large adjustments. Small adjustments are made at front brake lever by loosening knurled nut and turning cable adjuster. After adjustment, tighten knurled nut. Remove block from under ATC.

Free Play: 15–20 mm (5/8–3/4 in.)

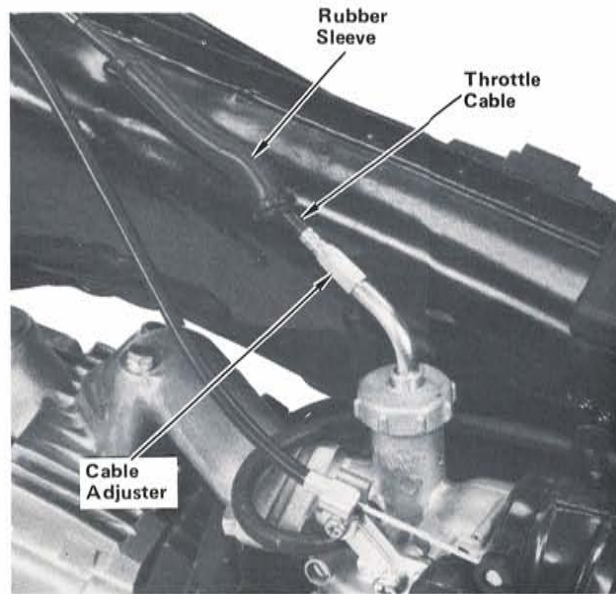
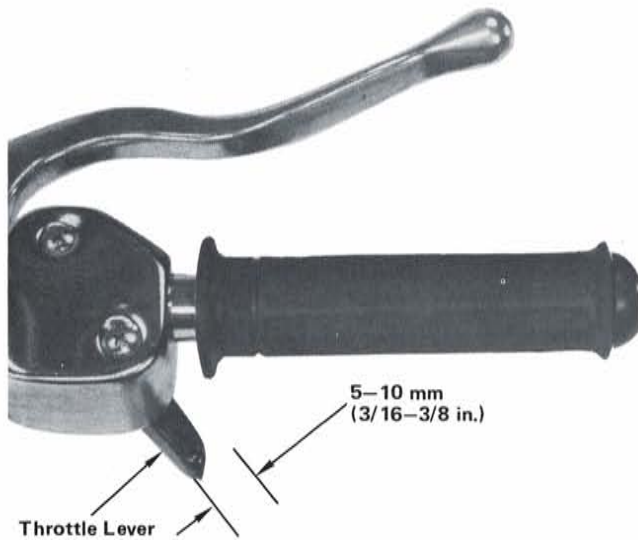

STEP 49—Check throttle lever free play. If adjustment is necessary, slide rubber sleeve on carburetor forward and turn throttle cable adjuster as necessary. Slide rubber sleeve back over adjuster.

Throttle lever free play: 5–10 mm (3/16–3/8 in.)

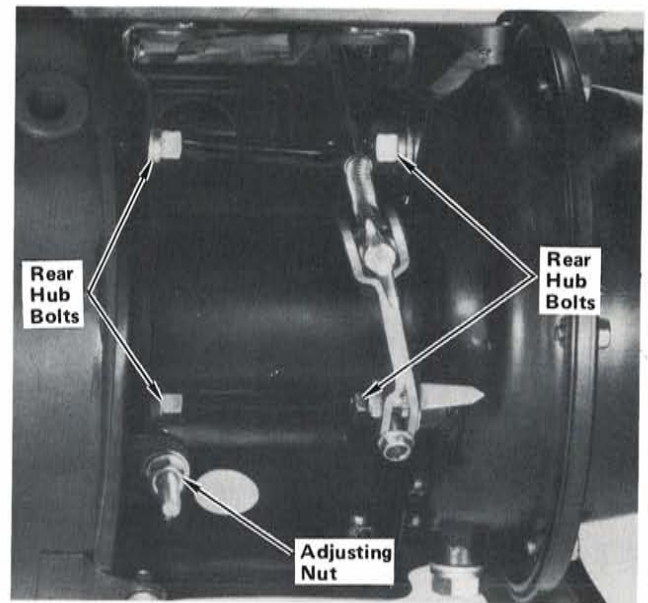
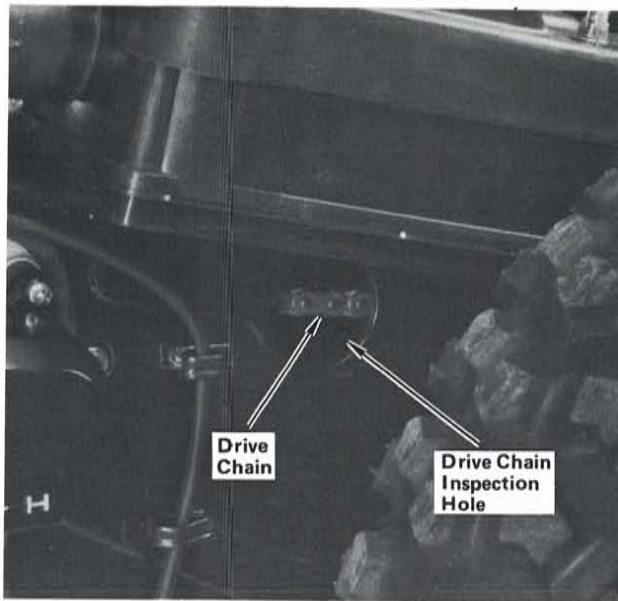

STEP 50—Remove drive chain inspection cap and check drive chain slack. If adjustment is necessary, loosen four rear hub bolts and turn adjusting nut as required. After adjustment, tighten rear hub bolts securely and reinstall drive chain inspection cap. Lubricate drive chain if necessary, as described in owner's manual.

Drive chain slack: 10–20 mm (3/8–3/4 in.)

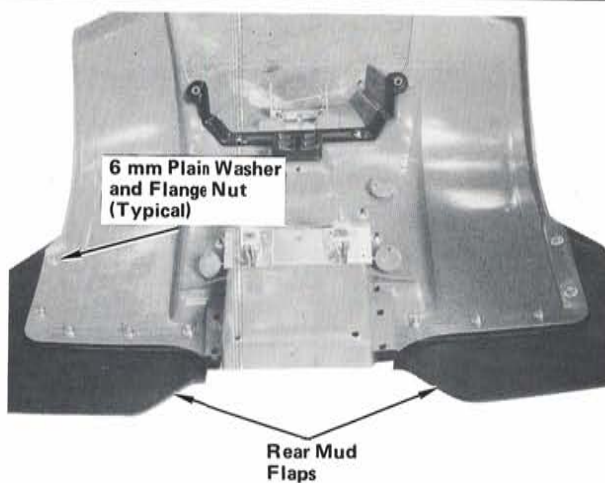

STEP 51—Install right and left rear mud flaps on rear fender by inserting studs on mud flaps down through fender with 6 mm plain washers and flange nuts under fender. Tighten nuts to specified torque.

Torque specification:
0.8 kg-m (6 lb-ft)

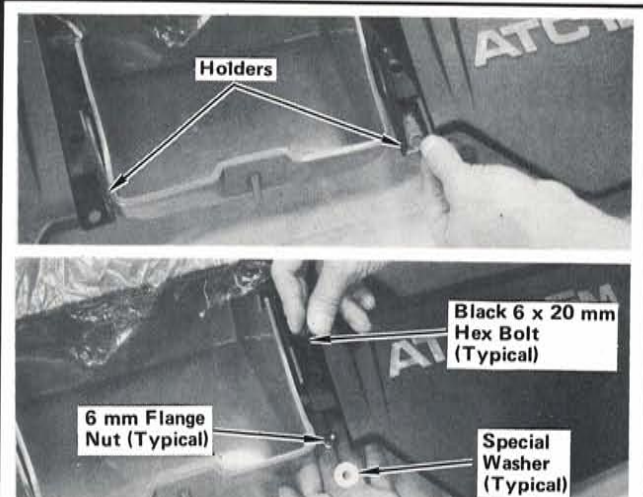

STEP 52—Position tool box cover holders (one on each side) between mud flap and rear fender and align the holes. Install holders using four 6 x 20 mm black hex bolts and collars down through holes, and four 6 mm special washers and flange nuts under fender. Tighten nuts securely.

NOTE: Right and left cover holders are identified by letters "R" and "L" on the inner surfaces.

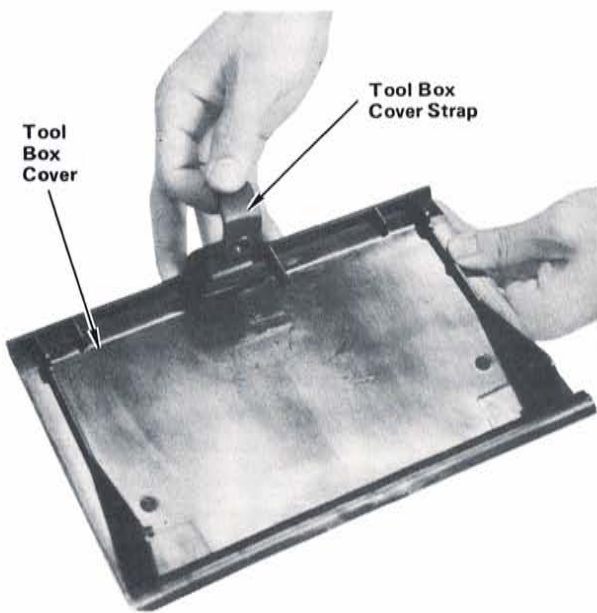

STEP 53—Install tool box cover strap as shown by coating end of rubber with soapy water and inserting end into slot in tool box cover.

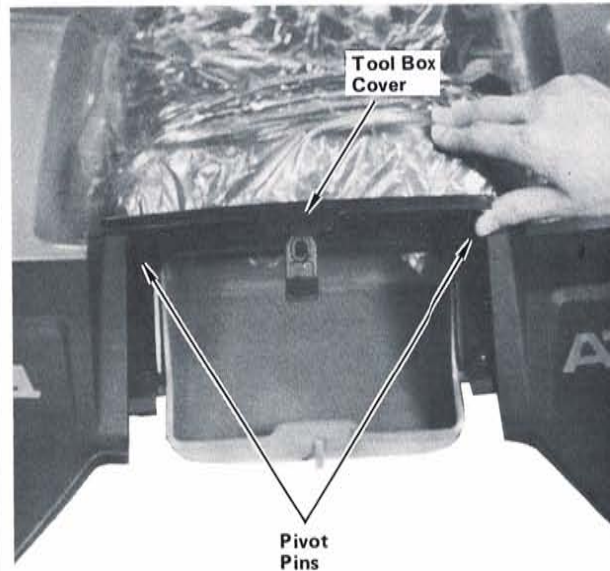

STEP 54—Snap tool box cover pivot pins into holes of cover holders as shown. Close cover and hook cover strap onto lug on tool box.

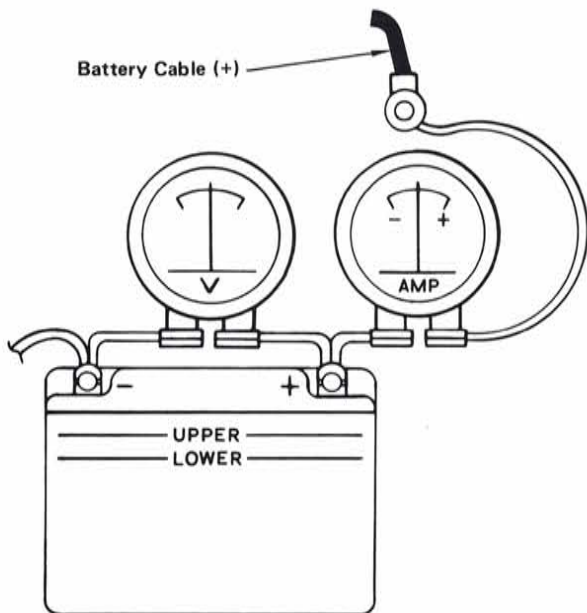

STEP 55—Check battery charging system (volts and amperes) at the battery, as described in the shop manual.

CAUTION

REMOVE BATTERY AND MAINTAIN IN FULLY CHARGED CONDITION UNLESS ATC IS TO BE DELIVERED IMMEDIATELY. REFER TO SERVICE BULLETIN SL NO. 48. DO NOT USE ELECTRIC STARTER IMMEDIATELY AFTER INSTALLATION OF A FRESHLY CHARGED BATTERY. SOME TIME IS REQUIRED FOR BATTERY TO ATTAIN FULL CAPACITY.

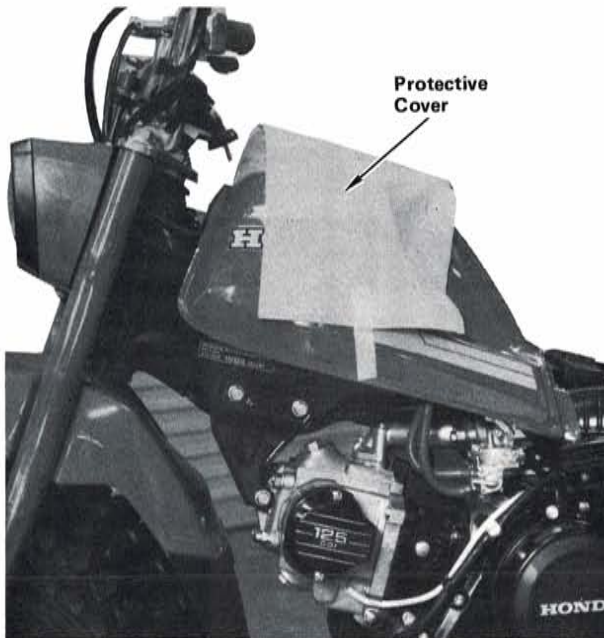

STEP 56—Remove protective cover from fuel tank.

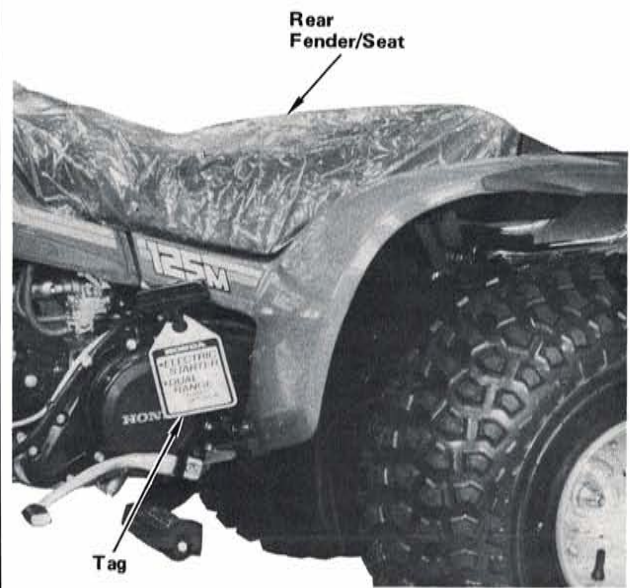

STEP 57—Install and latch rear fender/seat. Hang recoil starter/dual range transmission tag onto recoil starter handle.

TORQUE TABLE

ITEM	SIZE	TORQUE
Front fork bolts	-----	6.0 kg-m (44 lb-ft)
Handlebar holder bolts		2.4 kg-m (18 lb-ft)
Carrying handle bolts	10 x 180 mm	4.4 kg-m (32 lb-ft)
Rear wheel flange nuts	8 mm	2.2 kg-m (16 lb-ft)
Rear axle nuts	14 mm	7.0 kg-m (51 lb-ft)
Front fender bolts	6 x 20 mm	1.0 kg-m (8 lb-ft)
Front axle nuts	12 mm	6.0 kg-m (43 lb-ft)
Mud flap nuts	6 mm	0.8 kg-m (6 lb-ft)

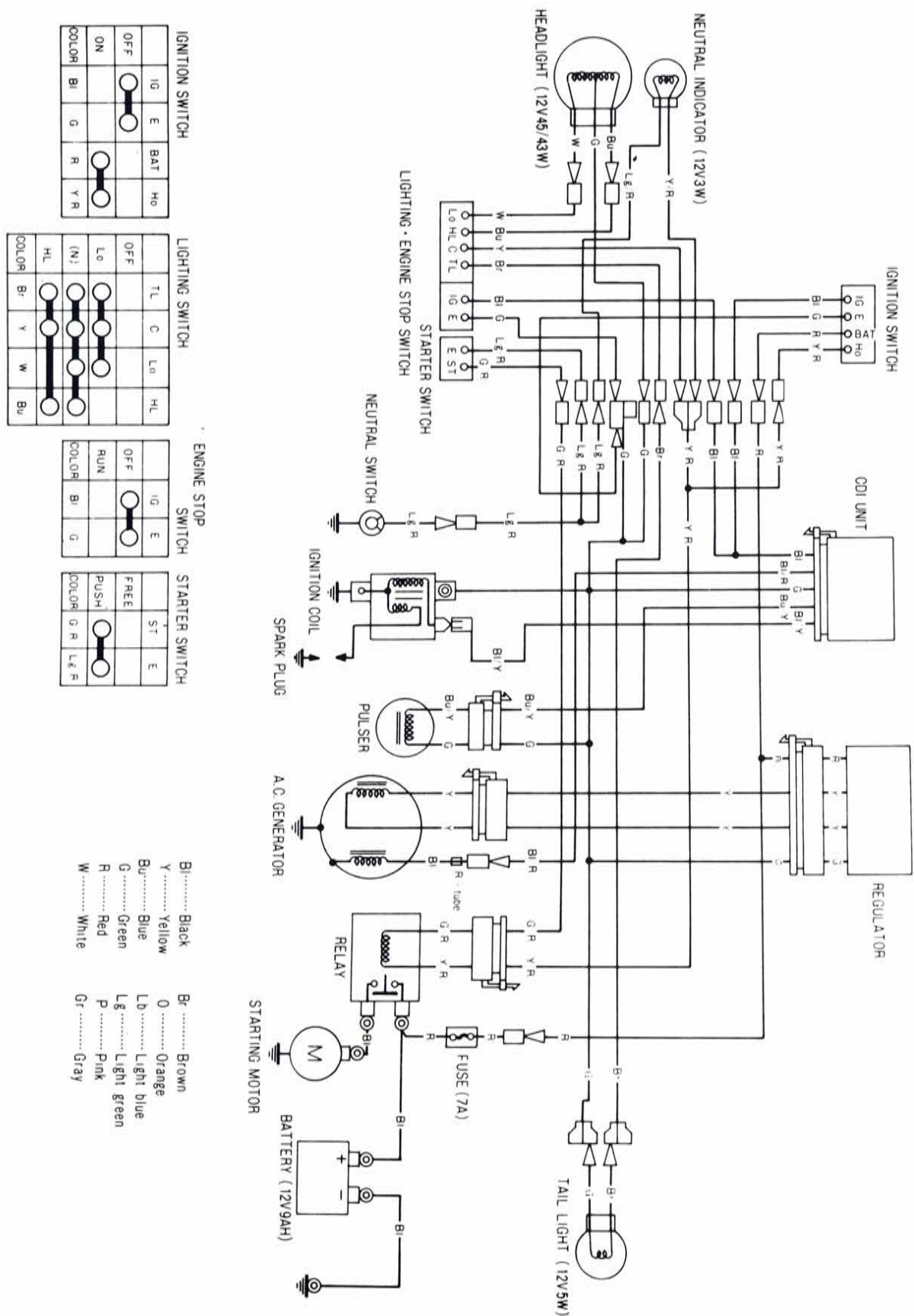

IGNITION SWITCH

	IG	E	BAT	HO
OFF	○	○	○	○
ON	○	○	○	○
COLOR	Bl	G	R	Y R

LIGHTING SWITCH

	TL	C	Lo	HL
OFF	○	○	○	○
Lo	○	○	○	○
(N)	○	○	○	○
HL	○	○	○	○
COLOR	Br	Y	W	Bu

ENGINE STOP SWITCH

	IG	E
OFF	○	○
RUN	○	○
COLOR	Bl	G

STARTER SWITCH

	ST	E
FREE	○	○
PUSH	○	○
COLOR	G R	L & R

- Bl.....Black
- Y.....Yellow
- Bu.....Blue
- G.....Green
- R.....Red
- W.....White
- Br.....Brown
- O.....Orange
- Lb.....Light blue
- Lg.....Light green
- P.....Pink
- Gr.....Gray

NOTE: Check all items listed on the following Pre-delivery Service Check List. Refer to owner's manual for specifications and detailed procedures. Always test ride the unit to make sure that it is functioning properly.

PRE-DELIVERY SERVICE CHECK LIST

- | | |
|---|---|
| <input type="checkbox"/> Adjust front and rear brakes, check cable routing and check operation. | <input type="checkbox"/> Check security of all nuts, bolts, and other fasteners. |
| <input type="checkbox"/> Fill crankcase with recommended oil, if necessary. | <input type="checkbox"/> Check to ensure that all applicable recall and product update campaigns are complied with. |
| <input type="checkbox"/> Remove and inspect fuel tank, drain and flush. | <input type="checkbox"/> TEST RIDE: Check performance, handling, and operation. |
| <input type="checkbox"/> Drain residual fuel from carburetor. | <ul style="list-style-type: none">• Transmission: high-low gear range selector, and clutch: Ease of shifting, clutch operation, etc.• Acceleration: Smoothness, etc.• Cruising: Smoothness, etc.• Handling: Stability and cornering.• Brakes: Smoothness and stopping power.• Idling: Smoothness, throttle response, and return to idle.• Recheck idle speed after 10 minutes of stop and go operation.• Upon completion of test ride, check for fuel and oil leaks. |
| <input type="checkbox"/> Reinstall fuel tank, fill, turn on petcock, and check for leaks. | |
| <input type="checkbox"/> Adjust idle speed. | |
| <input type="checkbox"/> Check throttle lever free play, cable routing, and operation in all steering positions. | |
| <input type="checkbox"/> Adjust and lubricate drive chain. | |
| <input type="checkbox"/> Check tire pressure. | |
| <input type="checkbox"/> Inspect electrical components for proper operation and adjustment. | |
| <ul style="list-style-type: none">• Headlight switch.• Headlight: Adjust high beam aim.• Taillight.• Engine stop switch.• Starter• Battery charging. | |

LOOSE PARTS LIST

The following is a list of items contained in the parts carton and loose parts in the crate.

DESCRIPTION	QTY	H/C	PART NUMBER
Front wheel assy	1	-----	-----
Rear wheel assy	2	-----	-----
Front axle	1	1495985	44301-943-000
Front axle collar	2	1510460	44302-968-000
Front axle side collar	1	1508548	44312-968-000
12 mm axle nut	2	0955625	90305-169-000
3.0 x 25 mm cotter pin	2	0058420	94201-30250
Handle cover	1	1519461	53205-958-682
Handle cover mark	1	1274760	53206-958-003
6 x 20 mm screw washer	2	0878538	93891-06020-08
Front fender	1	-----	61110-943-023
Front mud guard	1	1536580	61111-943-033
Front fender collar	4	-----	92002-957-000
6 x 20 mm hex bolt	4	0442103	92000-06020-0H
6 mm cap nut	4	0203620	94021-06000-0S
6 mm plain washer	8	0629824	94103-06800
Brake lock spring A	1	0271056	95014-73100
Brake arm joint B	1	0400945	95015-32001
Brake adjust nut	1	0710921	43459-434-000
13.5 x 1.4 mm O-ring	2	0347906	91307-611-000
Rear wheel hub comp.	2	1275163	42410-958-671
8 mm hex nut	8	0167338	94001-08000-0S
8 mm lock washer	8	0058982	94111-08000
14 mm washer	2	1074327	42322-950-000
14 mm castle nut	2	0234021	94011-14000-0S
3.0 x 25 mm cotter pin	2	0058420	94201-30250
10 mm flange nut	2	0623405	94050-10080
Carrying handle	1	-----	-----
10 x 180 mm hex bolt	2	0263079	90196-918-000
Tool kit	1	0709287	89000-943-000
6 x 20 mm washer	2	0191494	90512-300-000
Tool box assy	1	-----	83500-968-000
6 x 16 mm bolt/washer	2	0665133	93493-06016-08
Rear fender with seat	1	-----	-----
Tool box cover holder	1	1412980	80251-943-013
Tool box cover holder	1	1405356	80256-943-013
6 x 20 mm hex bolt	4	1304484	92000-06020-0G
Rear mud guard collar	4	1520881	80117-943-010
6 mm plain washer	14	0629824	94103-06800
Right rear mud guard	1	1508829	80111-968-000
Left rear mud guard	1	1508845	80116-968-000
6 mm flange nut	14	0612689	94050-06080
Battery breather tube	1	1508126	31502-968-000
Tool box lid	1	1494855	80211-943-023
Tool box band	1	1304401	80214-943-000
Owner's manual	1	1509231	31968600

(

(

(

(

(

(

(

READ THIS READ THIS READ THIS

HONDA

MODIFICATIONS WHICH YOU HAVE MADE, OR SHOULD MAKE IN THE FUTURE, TO ANY HONDA MOTORCYCLE, SHALL BE DEEMED BY OUR COMPANY TO HAVE BEEN PERFORMED AT YOUR SOLE RISK AND RESPONSIBILITY, AND WITHOUT OUR COMPANY'S OR THE MANUFACTURER'S APPROVAL OR CONSENT, IMPLIED OR EXPRESSED. WE FURTHER DISCLAIM ANY AND ALL LIABILITY, OBLIGATION, OR RESPONSIBILITY FOR ANY DEFECTS OF MODIFIED PARTS OR OF THE MODIFIED MOTORCYCLE, AND FOR ANY CLAIMS, DEMANDS, OR CAUSES OF ACTION FOR DAMAGE TO PROPERTY OR FOR PERSONAL INJURIES RESULTING FROM THE MODIFICATION OF SAID HONDA MOTORCYCLE.

READ THIS READ THIS READ THIS

READ THIS READ THIS READ THIS