

# Set-up Instructions

# 1986 Model ATC350X



MPD 9315 8509

AMERICAN HONDA MOTOR CO., INC.  
100 WEST ALONDRA BOULEVARD, GARDENA, CALIFORNIA 90247

**WARNING**

**WARNING**

**WARNING**

**WARNING**

**SET-UP AND PRE-DELIVERY SERVICE MUST BE PERFORMED BY AN AUTHORIZED HONDA ALL TERRAIN VEHICLE (ATV) DEALER.** Proper set-up and pre-delivery service is essential to rider safety and reliability of the vehicle. When a customer takes delivery of his brand new vehicle he expects it to be in excellent running condition. There are few things that will cause greater customer dissatisfaction than poor preparation of a new vehicle. An error or oversight made by the mechanic assembling and servicing a new unit can easily result in faulty operation, damage to the vehicle, or even injury to the rider.



*NOTE: Right and left are determined from the rider's view.*

Date of Issue: 9/85

© American Honda Motor Co., Inc. 1985 - All Rights Reserved

1 of 25

# SET-UP INSTRUCTION REVISED PAGES

**Pages Affected**

1 through 25

**Rev. Date**

Original

Remove and destroy superseded pages.

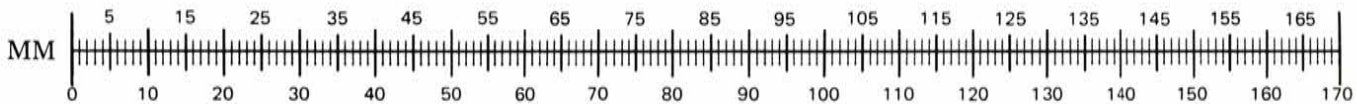

METRIC SCALE FOR DETERMINING BOLT LENGTHS/DIAMETERS

Pay special attention to warnings, cautions, and notes.

**WARNING** means hazards or unsafe practices which could cause severe personal injury or death.

**CAUTION:** means hazards or unsafe practices which could cause minor personal injury or product or property damage.

*NOTE:* gives helpful information.

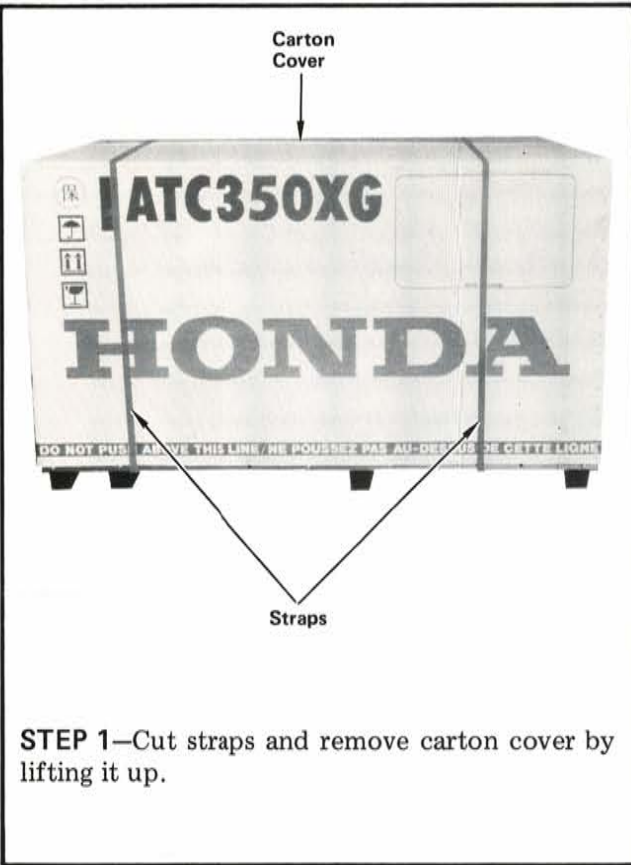

**STEP 1**—Cut straps and remove carton cover by lifting it up.

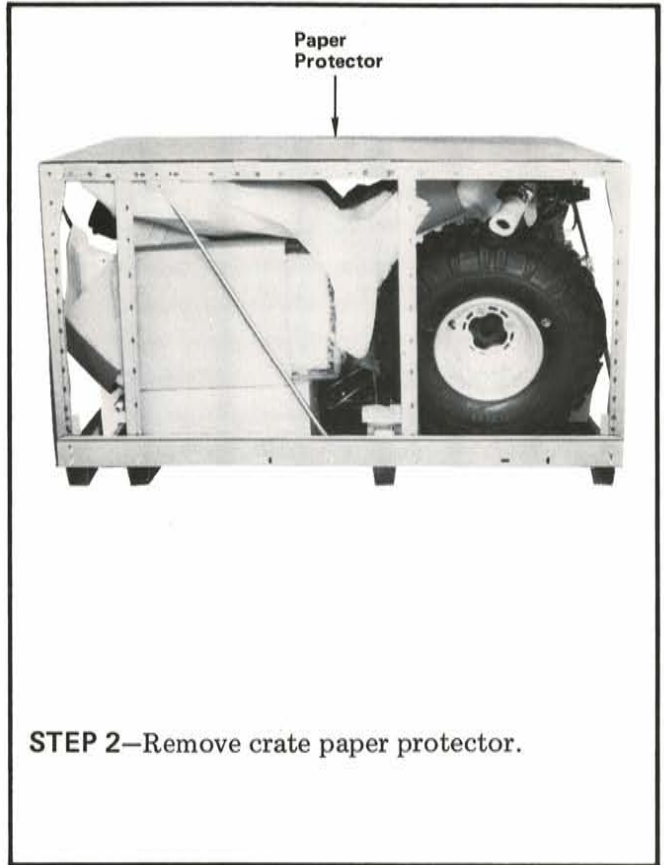

**STEP 2**—Remove crate paper protector.

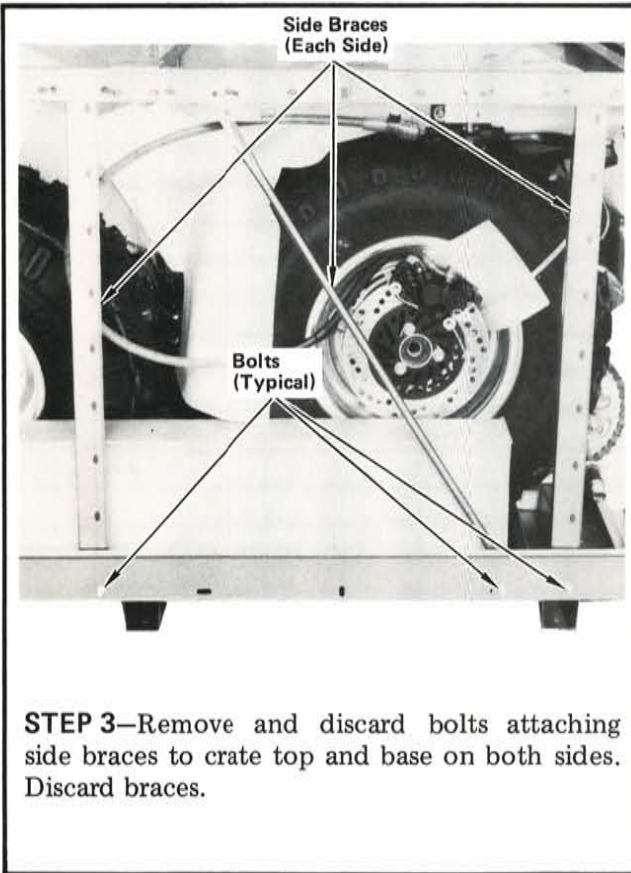

**STEP 3**—Remove and discard bolts attaching side braces to crate top and base on both sides. Discard braces.

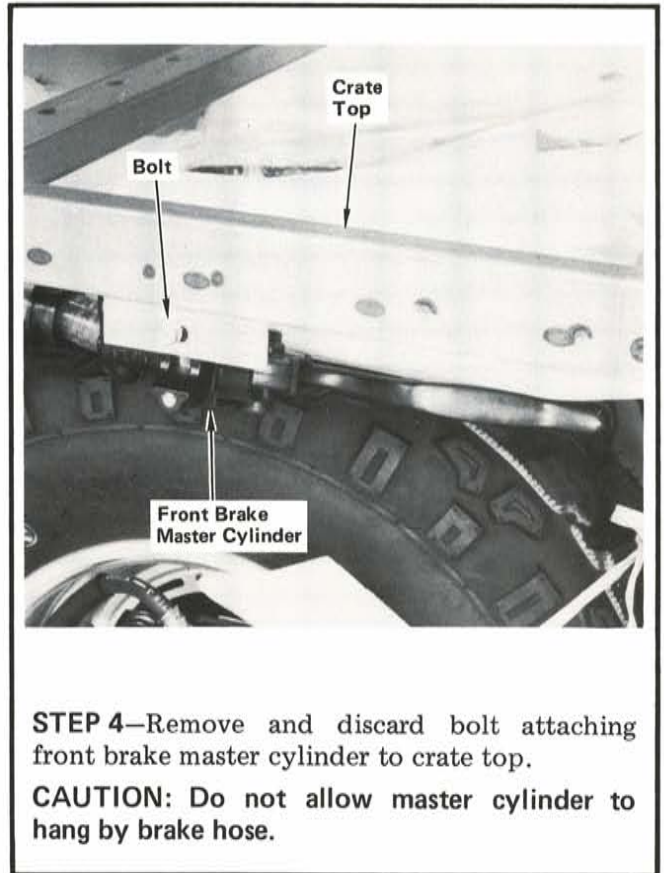

**STEP 4**—Remove and discard bolt attaching front brake master cylinder to crate top.

**CAUTION:** Do not allow master cylinder to hang by brake hose.

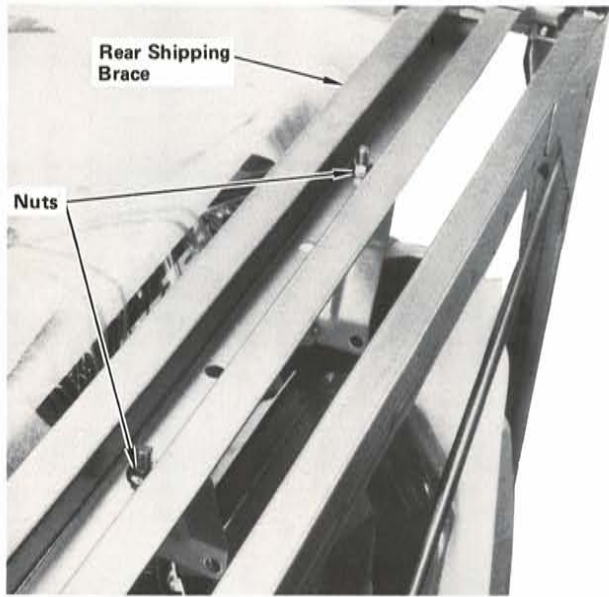

**STEP 5**—Remove and discard nuts attaching rear frame bracket to rear shipping brace.

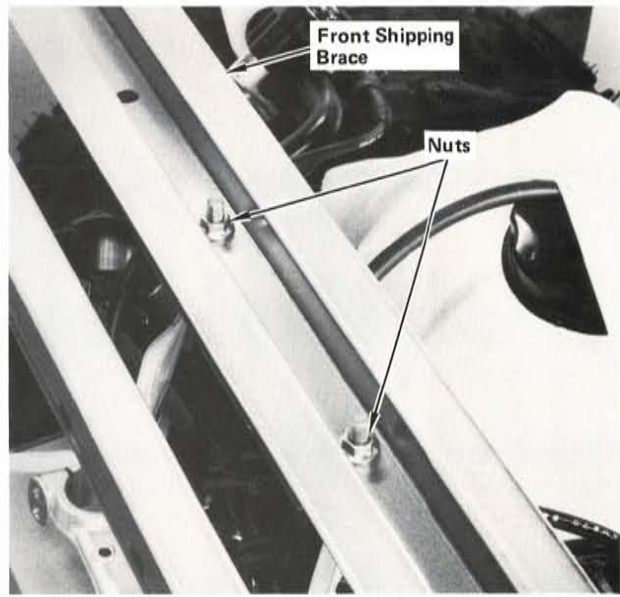

**STEP 6**—Remove and discard nuts attaching upper fork bridge to front shipping brace.

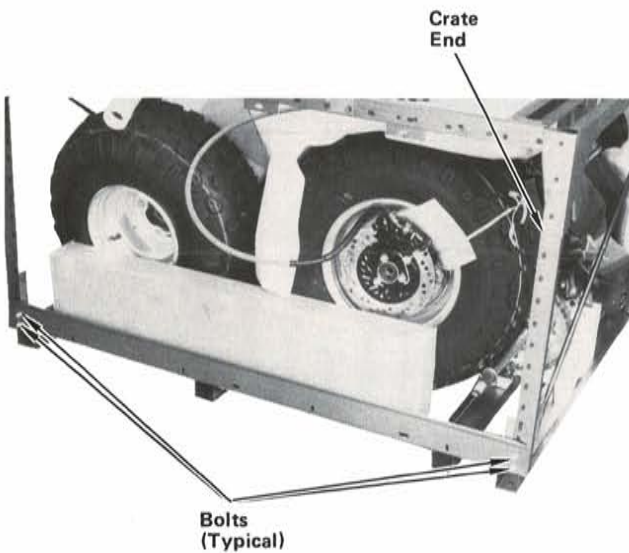

**STEP 7**—Remove and discard bolts attaching crate ends to crate base. Carefully lift off metal crate frame using two people. Discard side braces and crate frame.

**CAUTION:** Use extreme care not to damage vehicle with crate frame.

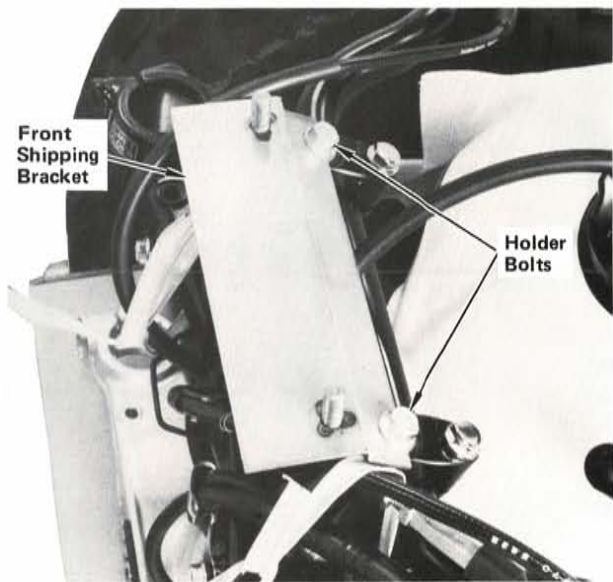

**STEP 8**—Remove handlebar holder bolts and remove front shipping bracket. Retain bolts.

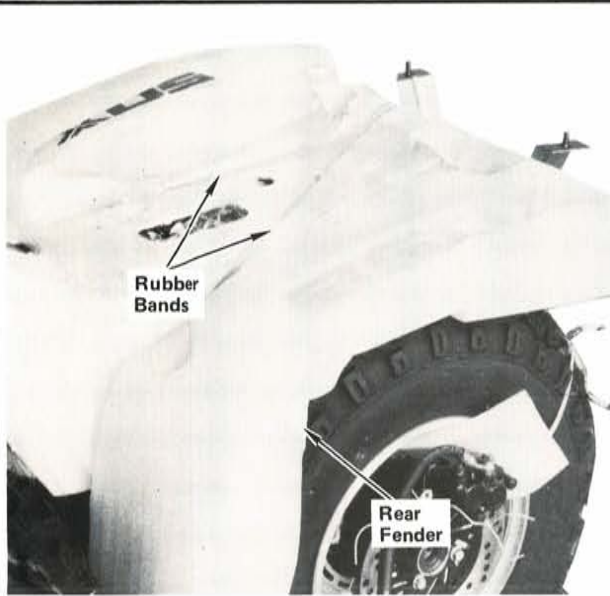

**STEP 9**—Remove rear fender by removing rubber bands.

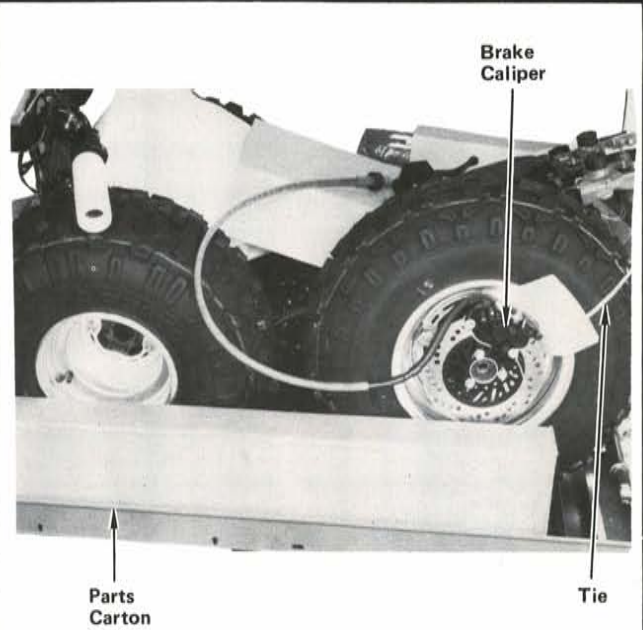

**STEP 10**—Remove parts carton from crate base. Remove and discard strap attaching front wheel to frame. Remove tie and protector attaching front brake caliper to front wheel. Remove wheels from crate base.

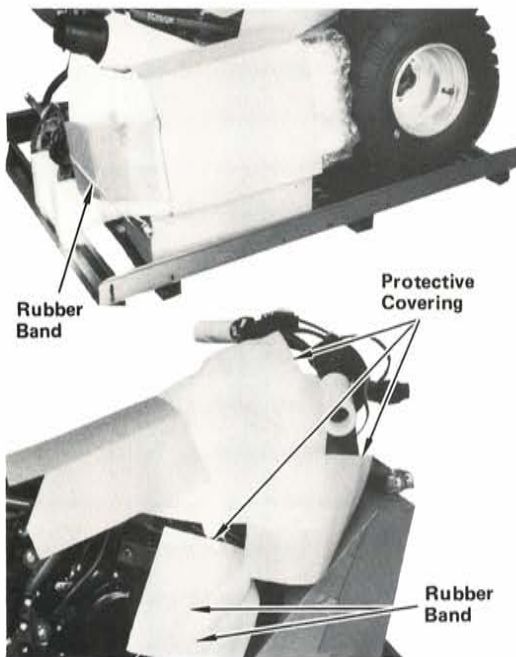

**STEP 11**—Remove the other wheel and parts carton from crate base. Remove and discard protective covering by removing rubber band. Remove parts carton from base.

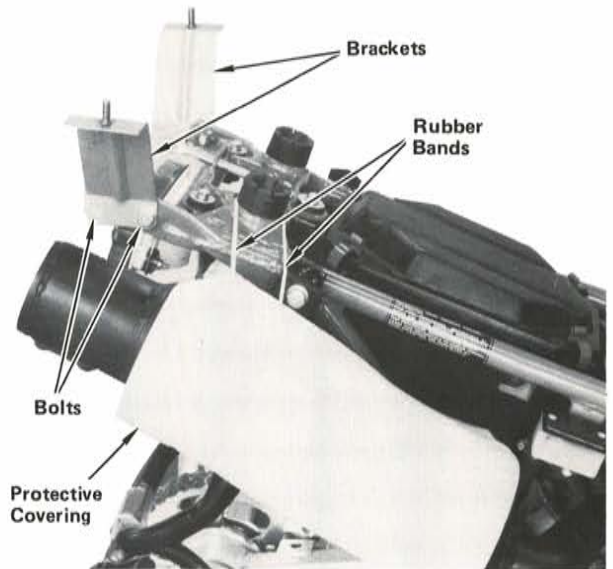

**STEP 12**—Remove and discard bolts attaching rear shipping brackets to frame. Remove and discard rubber bands and protective covering.



**STEP 13**—Unpack remaining loose parts and check against this illustration. Report any damaged or missing parts immediately to American Honda Motor Co., Inc., 100 West Alondra Blvd., Gardena, California 90247.

#### Damaged or Missing Parts

Identify missing parts by referring to the "Loose Parts List" on the following pages. Order parts through normal parts ordering procedures.

It is necessary to differentiate between parts lost or damaged in transit, and parts left out by the factory.

- For parts lost or damaged in transit, file a SHIPPING DAMAGE CLAIM.
- For parts left out by the factory, file a M/C WARRANTY CLAIM SO908.

## LOOSE PARTS LIST

PART NAME	QTY	H/C	PART NUMBER
1. Rear wheel assembly	2	-----	-----
2. Front wheel	1	-----	-----
3. Front fender	1	-----	-----
4. Seat	1	2149391	77100-HA5-670
5. Rear fender	1	-----	-----
6. Right front fork	1	2155299	51400-HA5-671
Left front fork	1	2022051	51500-HA5-003
7. Tool box	1	2078228	83500-VM6-680
8. Engine guard	1	2149169	50360-HA5-670
9. Front axle	1	1828060	44301-HA2-000
Front axle collar "A"	1	1828078	44311-HA2-000
Front axle collar "B"	1	1828086	44312-HA2-000
10. Skid plate	1	2149151	50355-HA5-670
11. Attaching hardware			
Wire band	2	0468819	32161-404-000
6 mm flange nut, support bracket, fender bracket	10	0612689	94050-06080
8 x 16 mm flange bolt, carrying handle	1	1947167	96500-08016-00
Front brake			
6 x 20 mm flange bolt	1	2024222	96500-06020-00
Front brake hose clamp "A"	1	2021319	45461-HA5-000
Front brake hose clamp "B"	1	2021327	45462-HA5-000
Front brake clamp	1	2021335	45463-HA5-000
Brake hose guide	1	1828219	45468-HA2-000
Brake hose guide	1	2149060	45469-HA2-670
6 x 16 mm flange bolt	2	2028942	96500-06016-00
Engine guide			
8 x 20 mm flange bolt	1	2000065	90116-VM0-770
8 x 12 mm flange bolt	2	1455377	90190-MG3-000
8 mm plain washer	3	0059097	94101-08000
8 mm spring washer	1	0058982	94111-08000
4.0 x 40 mm cotter pin	2	1047679	94201-40400
8 x 40 mm flange, fork top, stem comp	8	1419258	90107-KF0-000
Rear side collar	2	1827757	42316-HA2-000
Skid Plate			
8 x 12 mm flange bolt	3	1455377	90190-MG3-000
8 mm plain washer	1	0876896	94103-08000
Front fender			
6 x 25 mm flange bolt	4	2024123	96400-06025-08
6.5 x 25 x 1.5 mm washer	4	1044288	90404-680-000
Helmet holder	1	2149235	50715-HA5-670

STEP 13—(Continued)

## LOOSE PARTS LIST ( Continued)

PART NAME	QTY	H/C	PART NUMBER
5 x 14 mm bolt/washer	1	2155497	90111-HA2-670
Master cylinder holder	1	1046374	45517-961-000
8 x 36 mm flange bolt, top bridge	2	0338293	90111-362-000
20 mm rear axle nut	2	2149649	90305-HA5-670
6 x 25 mm oval head screw	2	0420521	93700-06025-0B
8 x 50 mm flange bolt, front brake	3	2024164	96400-08050-00
Tool box collar	2	2078251	83511-VM6-680
Tool box stay "A"	1	2149458	83513-HA5-670
Tool box stay "B"	1	2149466	83514-HA5-670
12. Owner's manual bag	1	2088383	83642-HA0-680
13. Headlight assembly	1	-----	-----
14. Rear fender bracket	1	2022895	80101-HA5-000
15. Fender support bracket	1	2022945	80106-HA5-000
16. Seat latch plate	1	-----	-----
17. Tool set	1	2149540	89010-HA5-670
18. Starting procedure label "B"	1	2155430	87134-HA5-670
19. Owner's manual	1	-----	-----
20. Chain slider	1	1828680	52156-HA2-000

STEP 13—(Continued)



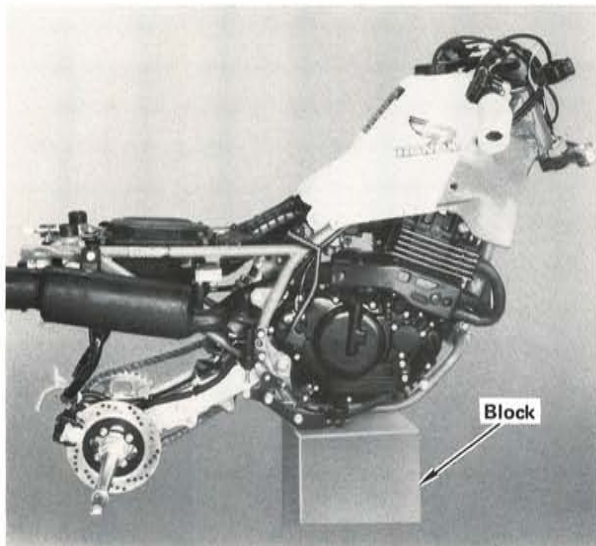

**STEP 14**—Carefully remove vehicle from crate base using a hoist or several people, and support on a padded block centered under engine as shown.

**CAUTION:** The vehicle can easily be tipped over until it is resting on the front and rear wheels.

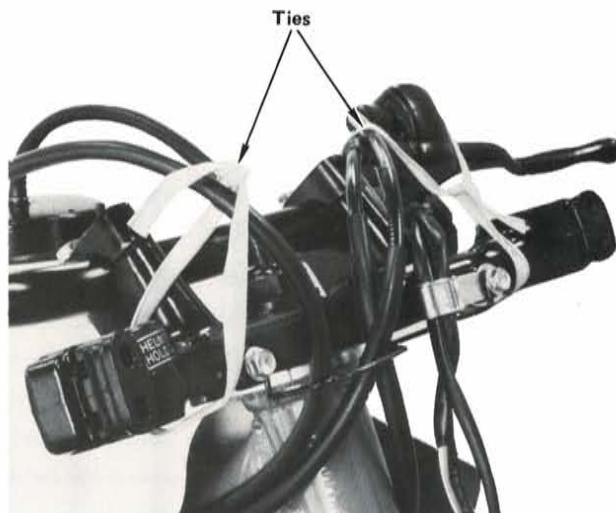

**STEP 15**—Release cables from upper fork bridge by removing ties.

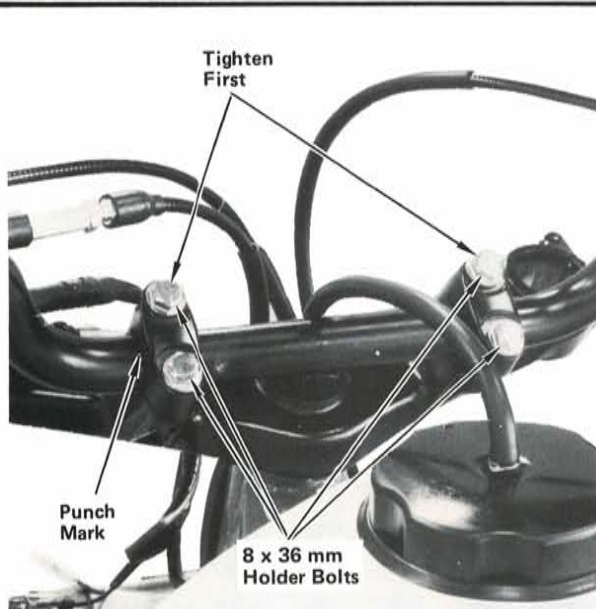

**STEP 16**—Lift handlebar grips up until punch mark on handlebar is aligned with top of lower holder. Tighten front bolts to specified torque first, then tighten rear bolts to same torque.

**Torque specification:**  
2.4 kg-m (18 lb-ft)

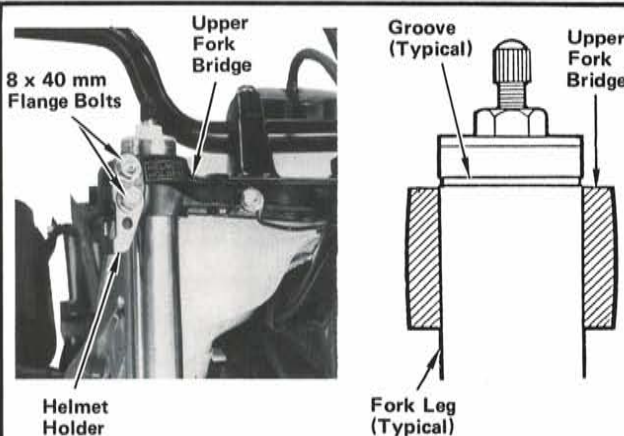

**STEP 17**—Slide right fork leg (leg with axle holder) up through lower and upper fork bridges. Align groove near upper end of fork tube with top of upper fork bridge. Position fork boot so upper boot band screw faces inward and axle holder faces forward. Insert two 8 x 40 mm flange bolts through helmet holder and into upper fork brace from the front side. Insert two 8 x 40 mm flange bolts into lower fork brace from the front side. Tighten bolts to specified torque.

**Torque specification:**  
2.1 kg-m (16 lb-ft)

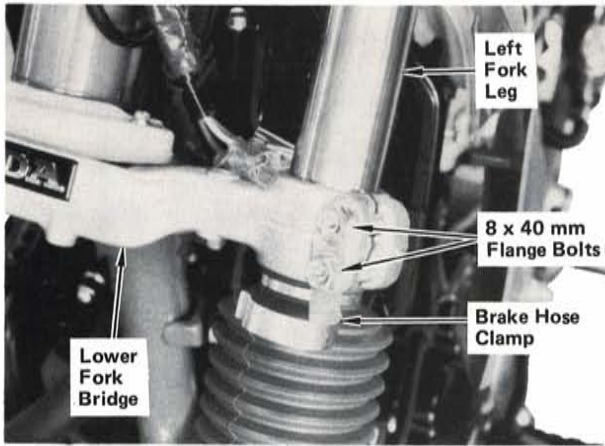

**STEP 18**—Slide left fork leg up through lower and upper fork bridges. Align groove near upper end of fork tube with top of upper fork bridge. Position fork boot so upper band screw faces inward, and axle boss faces forward. Insert two 8 x 40 mm flange bolts through brake hose clamp and into lower fork bridge from front to rear. Tighten bolts to specified torque.

**Torque specification:**  
2.1 kg-m (16 lb-ft)

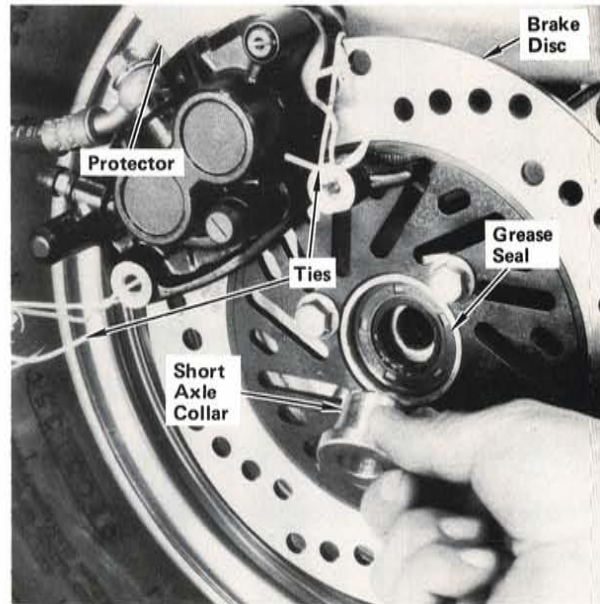

**STEP 19**—Insert left axle collar (short) into grease seal on brake disc side of front wheel. Remove ties attaching front brake caliper to front brake disc. Remove and discard protector between brake pads and disc.

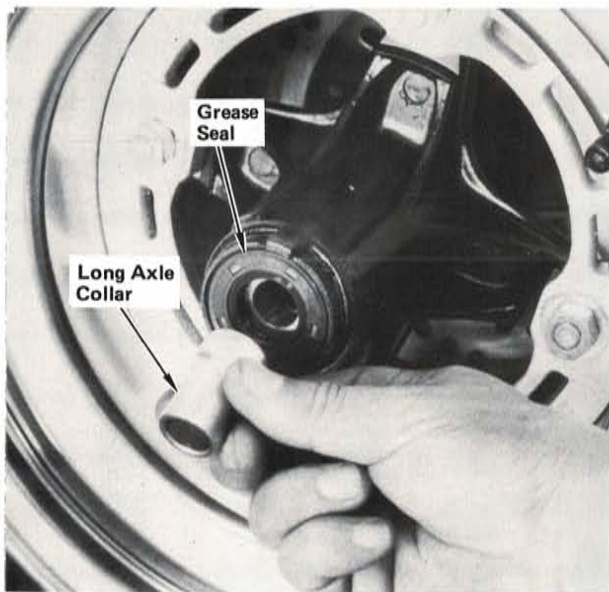

**STEP 20**—Insert right axle collar (long) into grease seal of front wheel on side opposite brake disc.

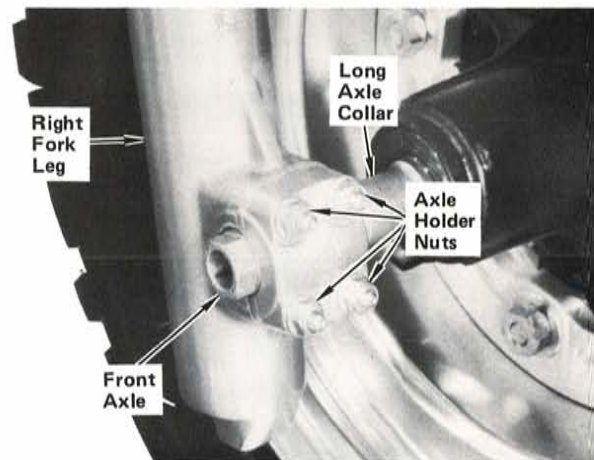

**STEP 21**—Position front wheel between fork legs with brake disc on left. Insert front axle from right side, through axle holder, long axle collar, wheel hub, short axle collar, and screw axle into left fork leg. Tighten axle to specified torque, then tighten axle holder nuts to specified torque.

**Torque specifications:**  
Front axle: 6.0 kg-m (44 lb-ft)  
Axle holder nuts: 1.2 kg-m ( 9 lb-ft)

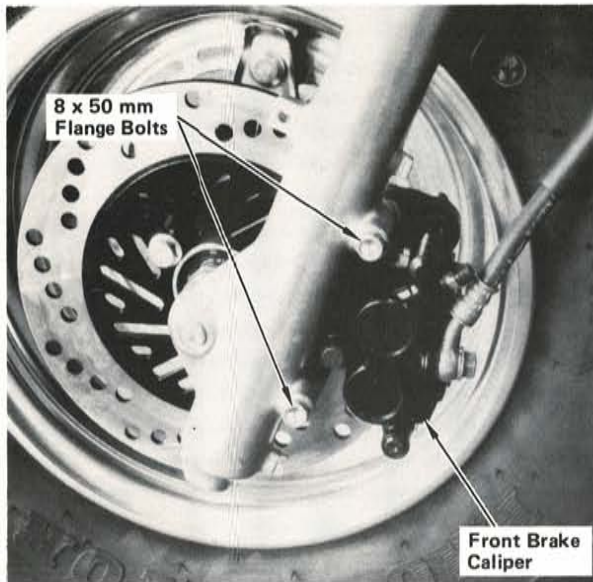

**STEP 22**—Carefully slip caliper over front brake disc. Align holes of caliper with holes in left fork leg. Install caliper using two 8 x 50 mm flange bolts. Tighten bolts to specified torque.

**Torque specification:**  
2.5 kg-m (18 lb-ft)

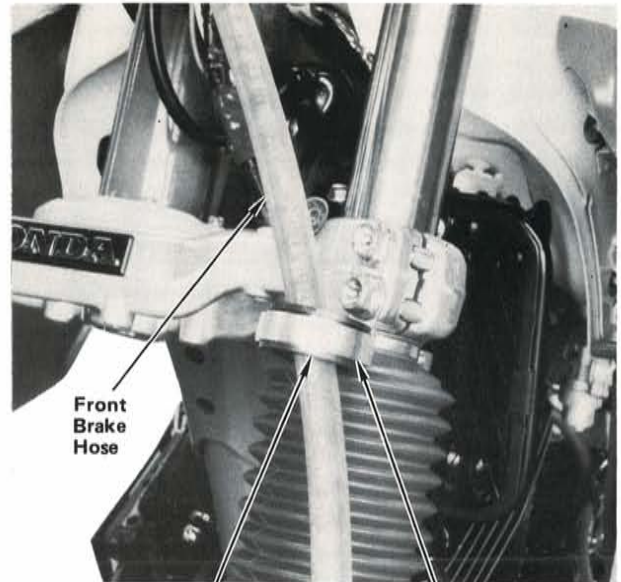

**STEP 23**—Press front brake hose plastic grommet into brake hose clamp on lower fork bridge.

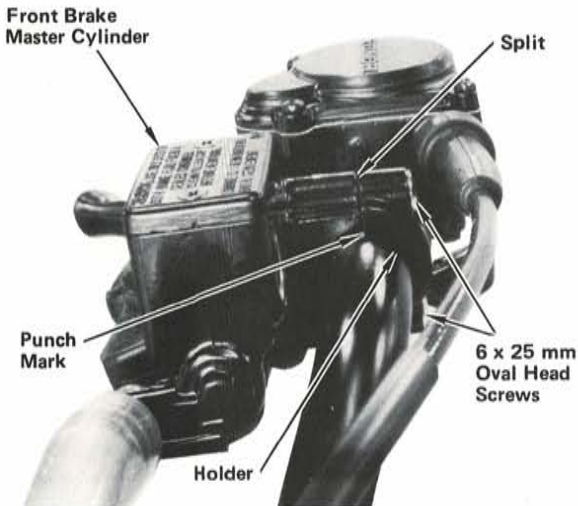

**STEP 24**—Assemble front brake master cylinder and holder, with “UP” arrow on holder pointing up. Loosely install two black 6 x 25 mm oval head screws. Position master cylinder so split aligns with punch mark on top of handlebar. Tighten upper holder screw to specified torque first, then tighten lower screw to same torque.

**Torque specification:**  
0.9 kg-m (7 lb-ft)

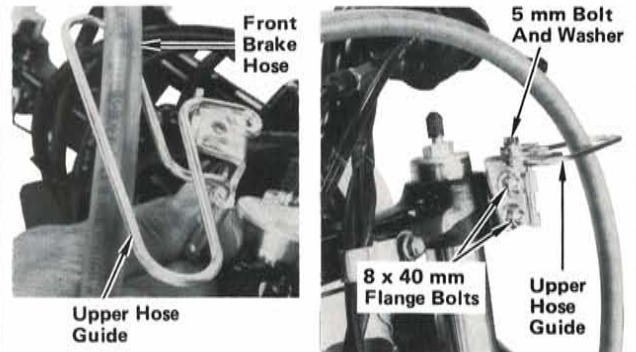

**STEP 25**—Slip upper brake hose guide over front brake hose. Position guide on upper fork bridge as shown and install using two 8 x 40 mm flange bolts inserted from front to rear through guide and into upper fork bridge. Tighten bolts to specified torque.

**Torque specification:**  
2.1 kg-m (16 lb-ft)

Secure end of guide using a 5 x 12 mm hex bolt and plain washer down through guide and into bracket. Tighten bolt to specified torque.

**Torque specification:**  
0.5 kg-m (4 lb-ft)

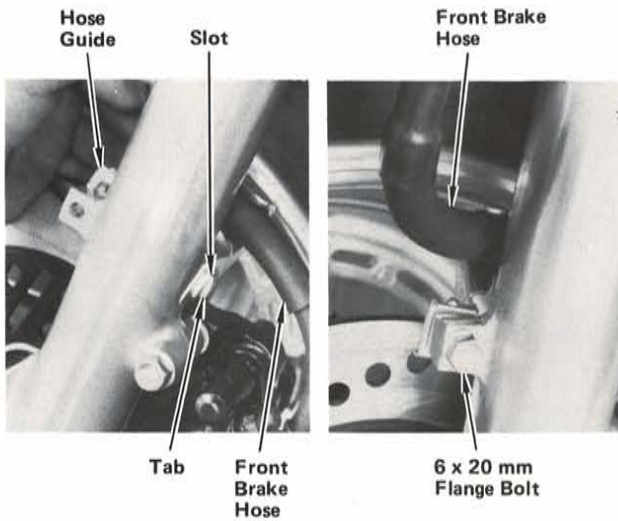

**STEP 26**—Position lower brake hose guide over brake hose inside of left fork leg. Hook slotted end of guide over tang on rear of fork leg and install using a 6 x 20 mm flange bolt through boss on front of fork leg. Tighten bolt to specified torque.

**Torque specification:**  
1.2 kg-m (9 lb-ft)

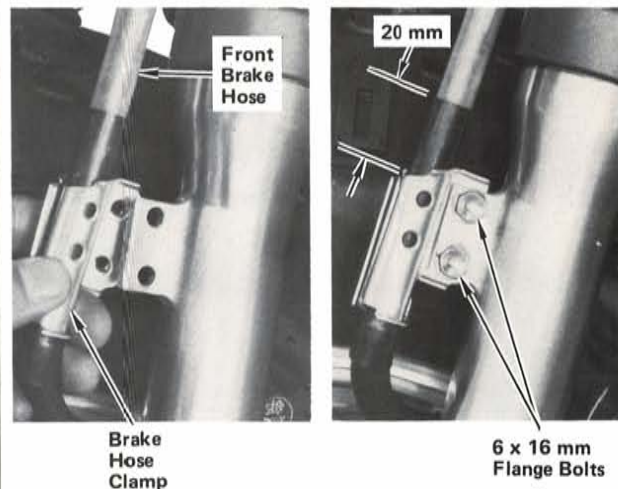

**STEP 27**—Insert brake hose into lower brake hose guide, then place front brake hose in brake hose clamp. Position upper end of brake hose protective tube 20 mm above brake hose clamp. Install clamp as shown using two 6 x 16 mm flange bolts. Tighten bolts to specified torque.

**Torque specification:**  
1.2 kg-m (9 lb-ft)

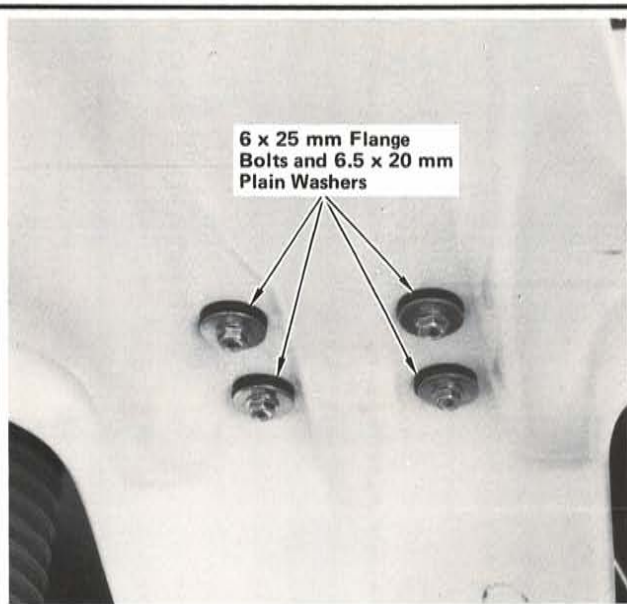

**STEP 28**—Position front fender between fork legs and install using four 6 x 25 mm flange bolts and special 6.5 x 20 mm plain washers. Tighten bolts to specified torque.

**Torque specification:**  
1.2 kg-m (9 lb-ft)

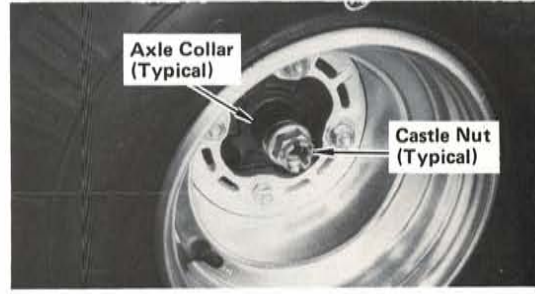
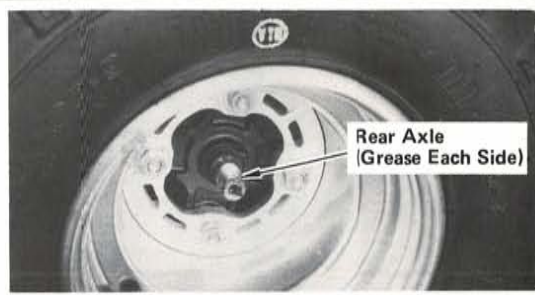

**STEP 29**—Grease rear axle splines and slip rear wheels onto axle with tire valves towards the outside as shown. Install rear wheels using an axle collar and castle nut for each.

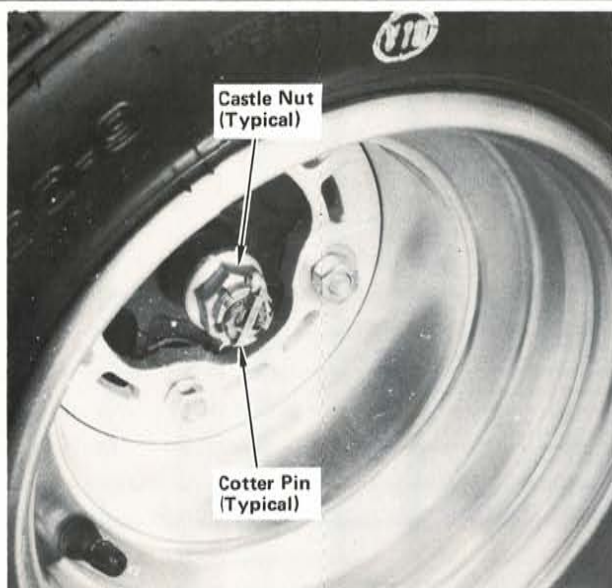

**STEP 30**—Tighten both castle nuts to specified torque equally, and install a cotter pin in each. Spread ends of cotter pins as shown.

**Torque specification:**  
14.5 kg-m (105 lb-ft)

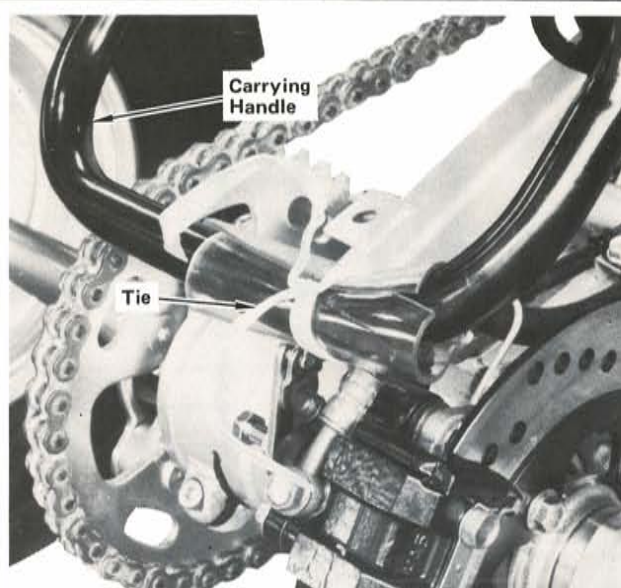

**STEP 31**—Remove tie holding carrying handle.

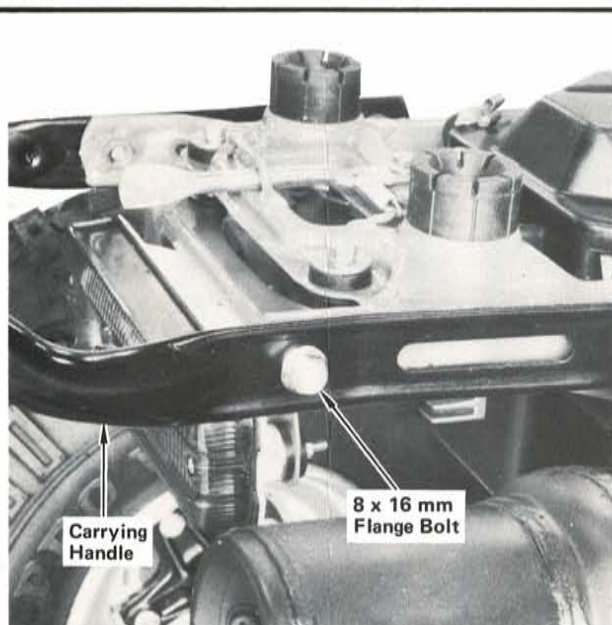

**STEP 32**—Loosely attach right side of carrying handle using an 8 x 16 mm flange bolt through collar into frame.



**STEP 33**—Remove and retain 8 x 50 mm flange bolt attaching left end of carrying handle.

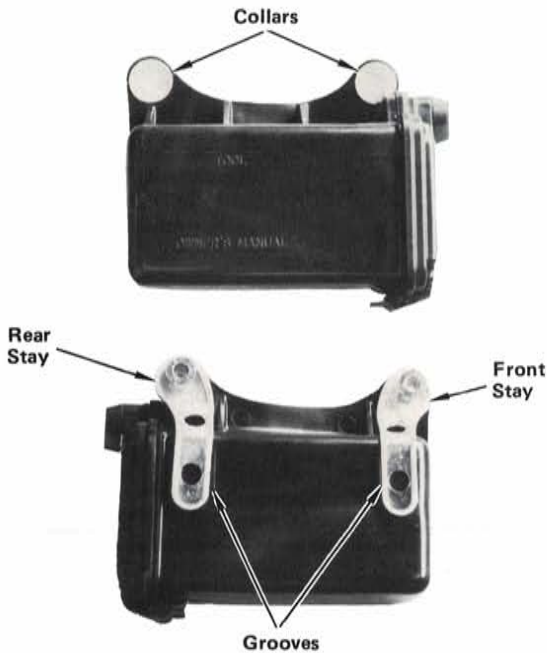

**STEP 34**—Check that stays are aligned with grooves in tool box.

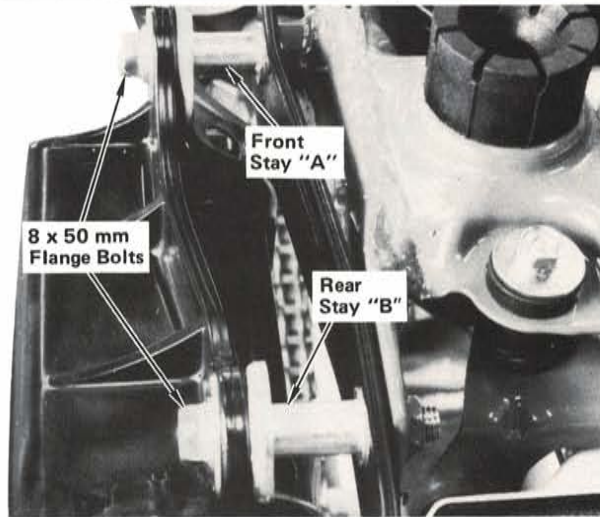

**STEP 35**—Install tool box on left side, positioned as shown, using front stay “A”, rear stay “B” between tool box tabs and carrying handle. Insert an 8 x 50 mm flange bolt (removed in Step 33) through forward tab and an 8 x 50 mm flange bolt through rear tab. Tighten four carrying handle bolts to specified torque.

**Torque specification:**  
2.7 kg-m (19 lb-ft)

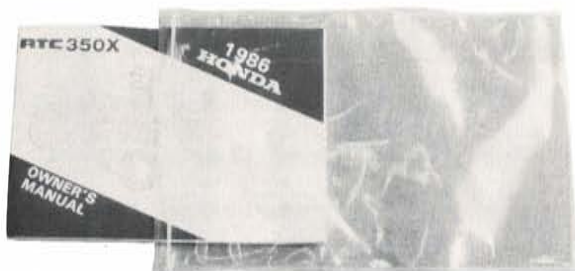

**STEP 36**—Insert owner’s manual in bag.

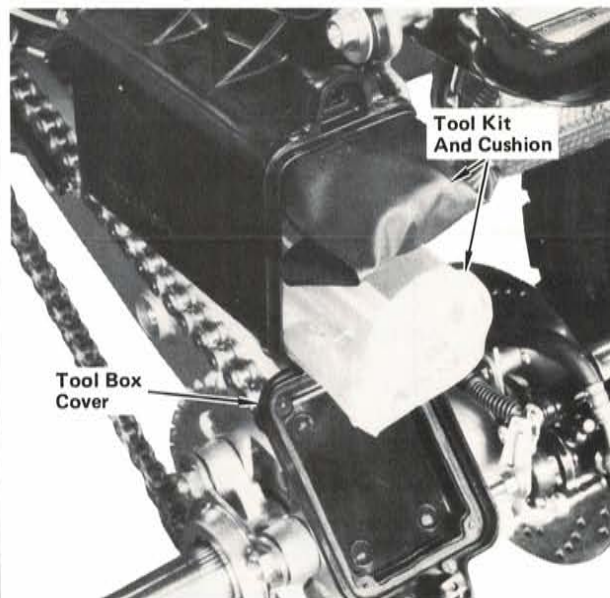

**STEP 37**—Open tool box cover and place tool kit and tool kit cushion in tool box. Close and lock tool box cover.

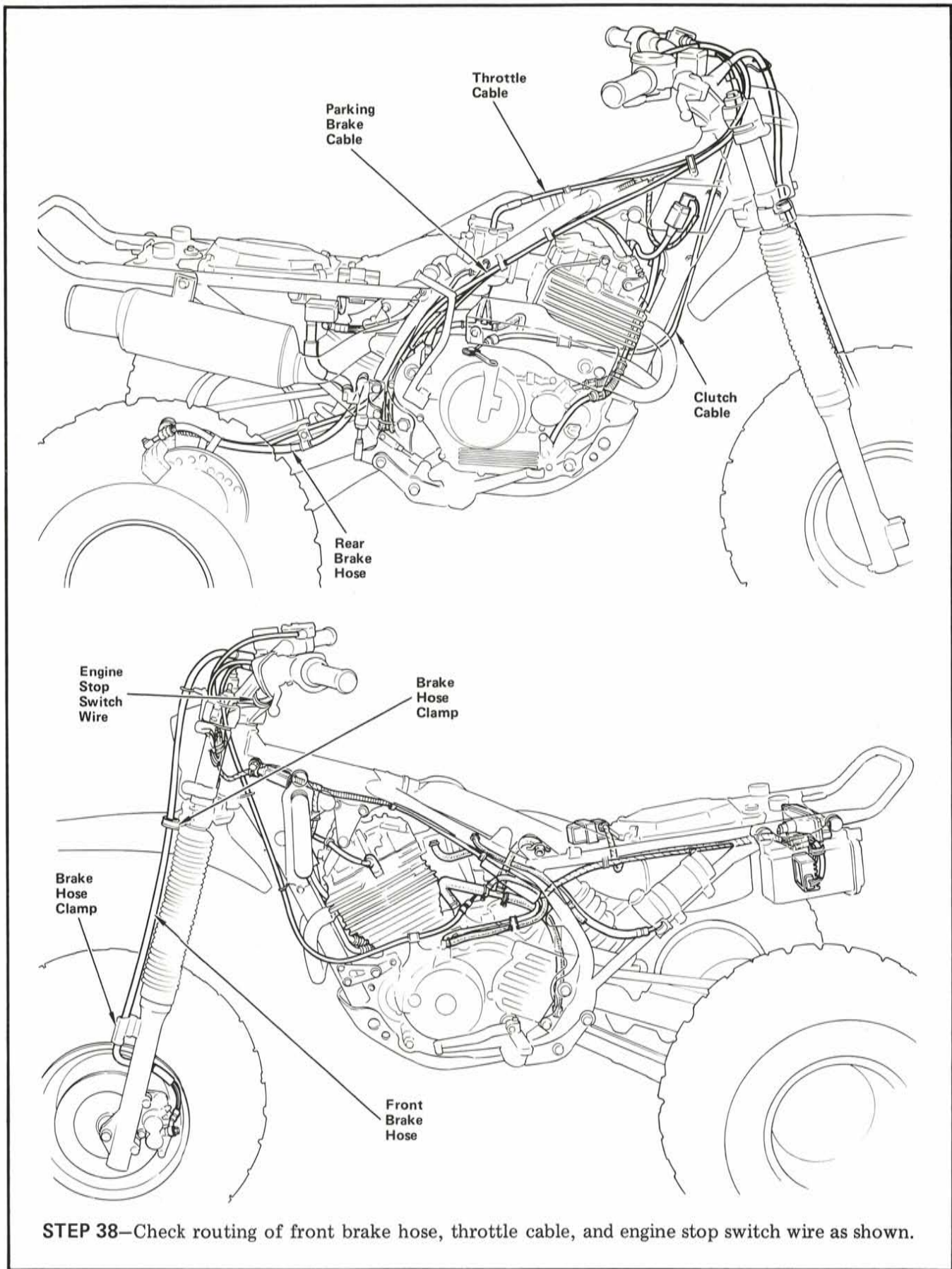

**STEP 38**—Check routing of front brake hose, throttle cable, and engine stop switch wire as shown.

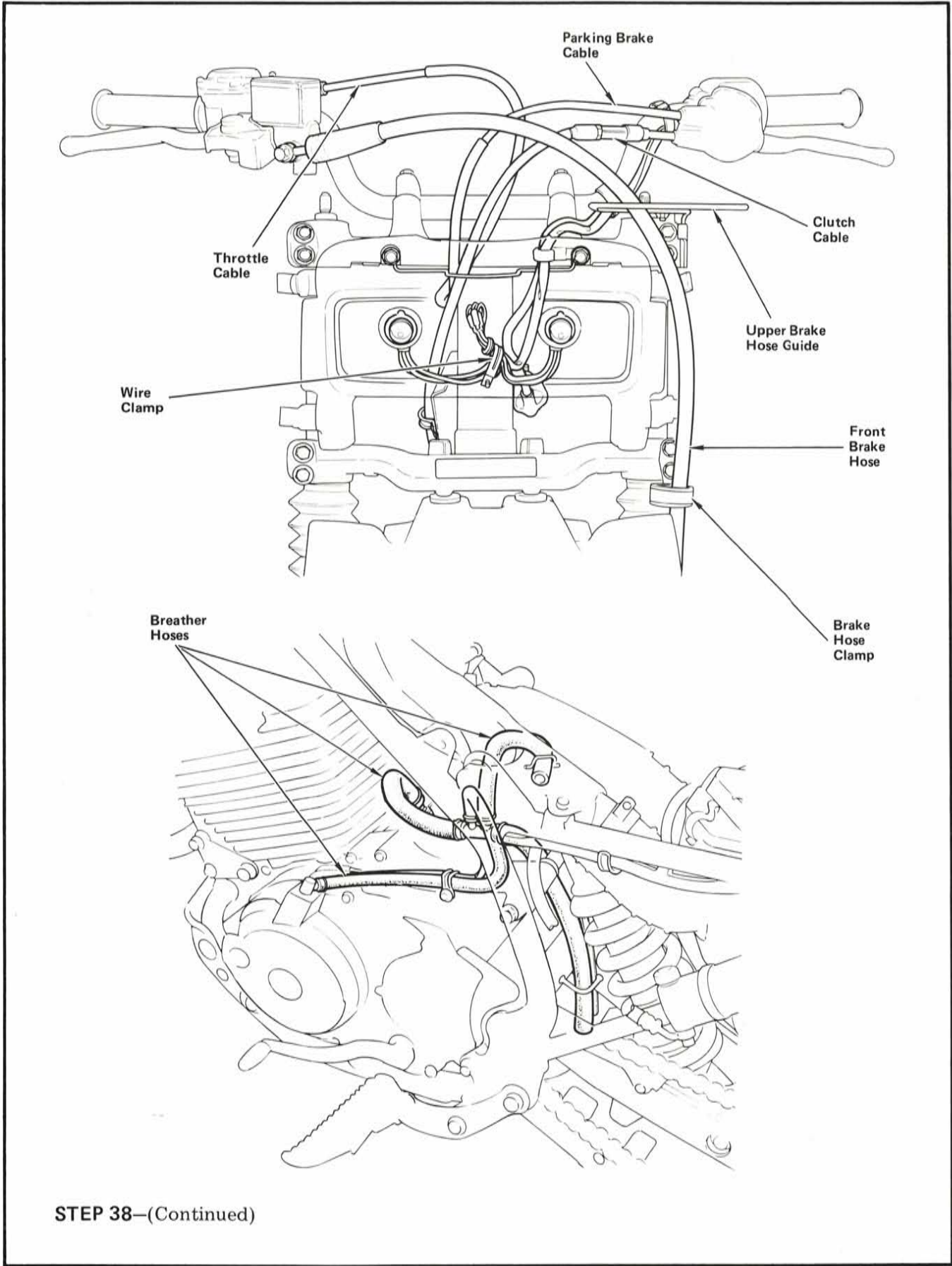



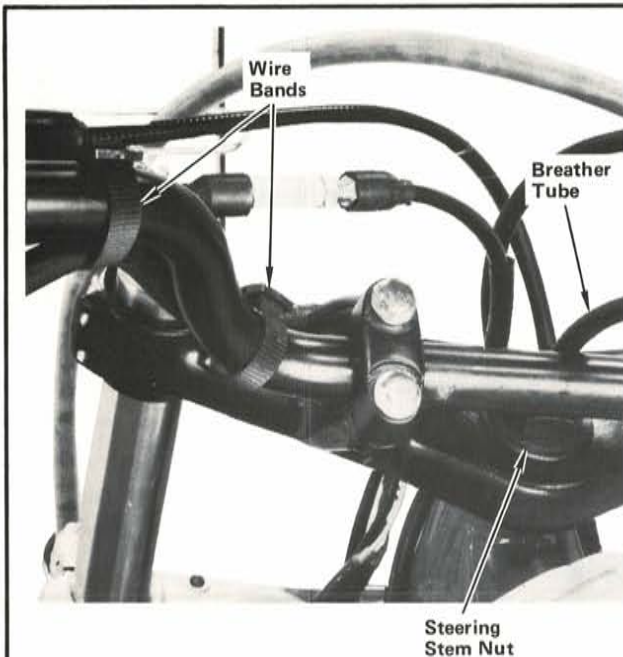

**STEP 39**—Attach handlebar wire harnesses to handlebar using two wire bands positioned where shown. Insert end of fuel tank cap breather tube into hole in steering stem nut as shown.

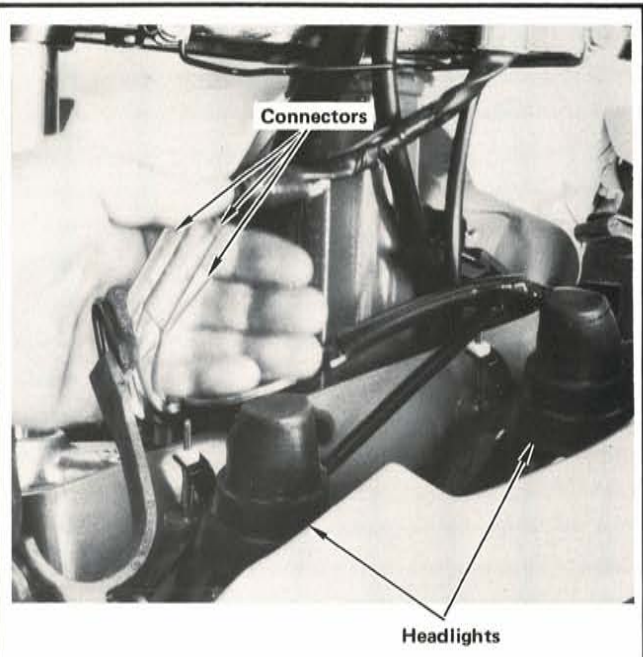

**STEP 40**—Connect headlight wires to wire harness color-to-color.

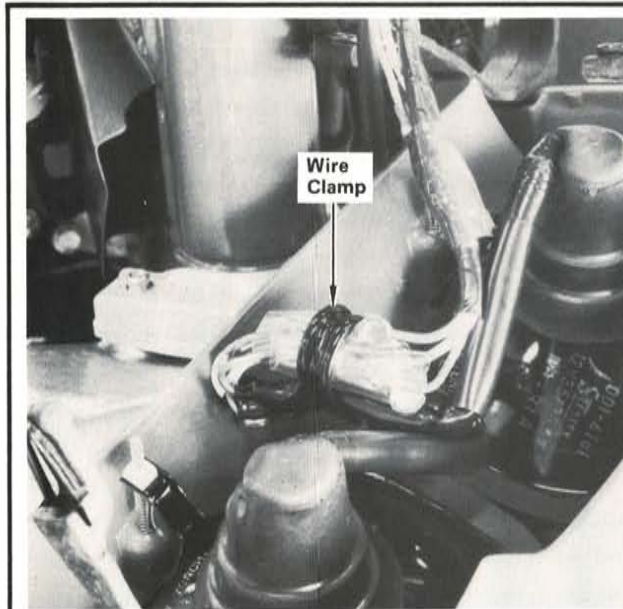

**STEP 41**—Squeeze wire clamp around headlight wires as shown.

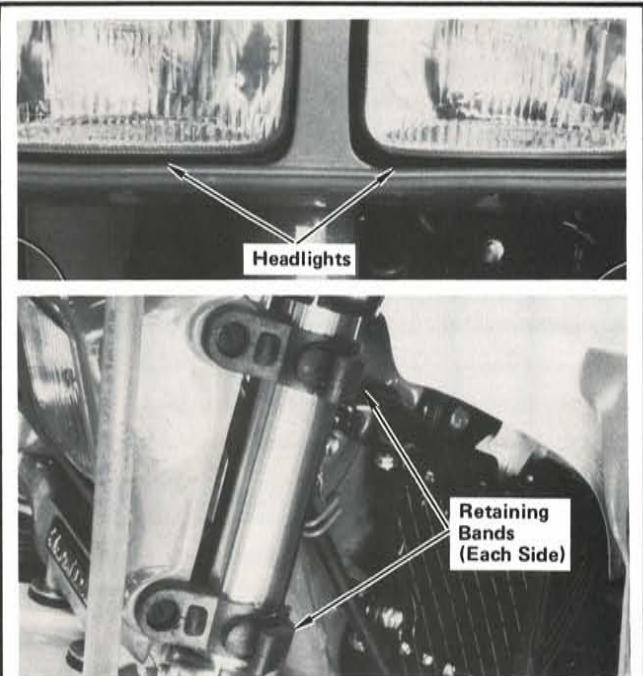

**STEP 42**—Position headlight in front of fork legs as shown, and secure with four headlight retaining bands as shown.

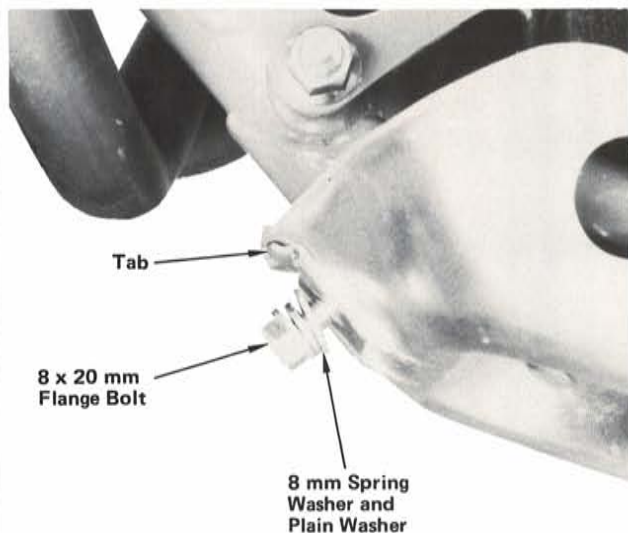

**STEP 43**—Hook tab on front of frame into slot in front of engine guard. Install front of skid plate using an 8 x 20 mm flange bolt and plain washer.

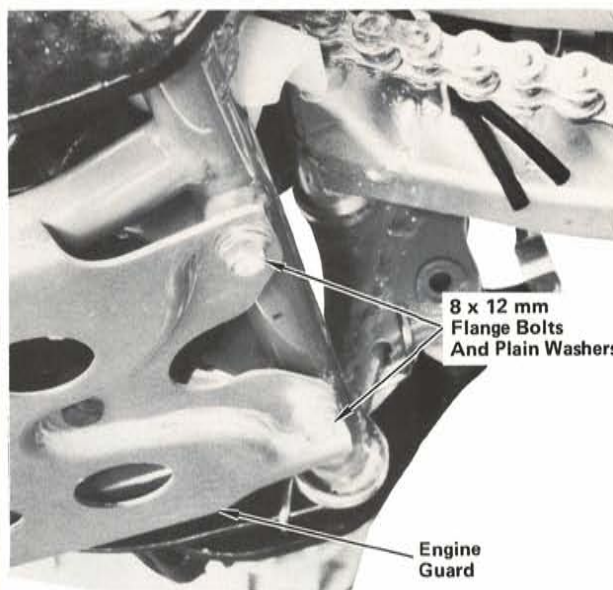

**STEP 44**—Install rear of engine guard using two 8 x 12 mm flange bolts and plain washers. Tighten all three attaching bolts to specified torque.

Torque specification:  
2.7 kg-m (19 lb-ft)

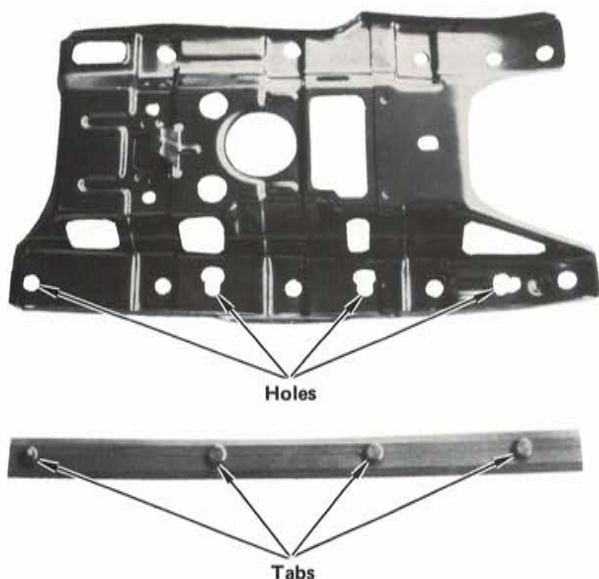

**STEP 45**—Press tabs of chain slider into holes in rear skid plate from the inside.

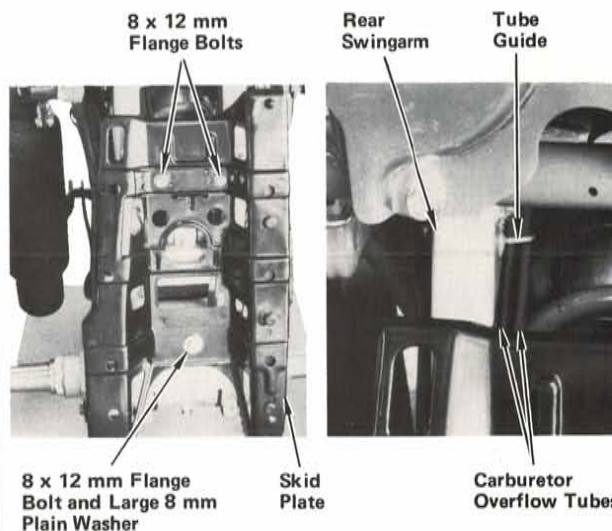

**STEP 46**—Position rear skid plate on frame as shown and install using three 8 x 12 mm flange bolts with an 8 mm plain washer under head of rear bolt. Tighten bolts to specified torque. Check that carburetor overflow tubes are routed through tube guide on rear swingarm.

Torque specification:  
2.7 kg-m (19 lb-ft)

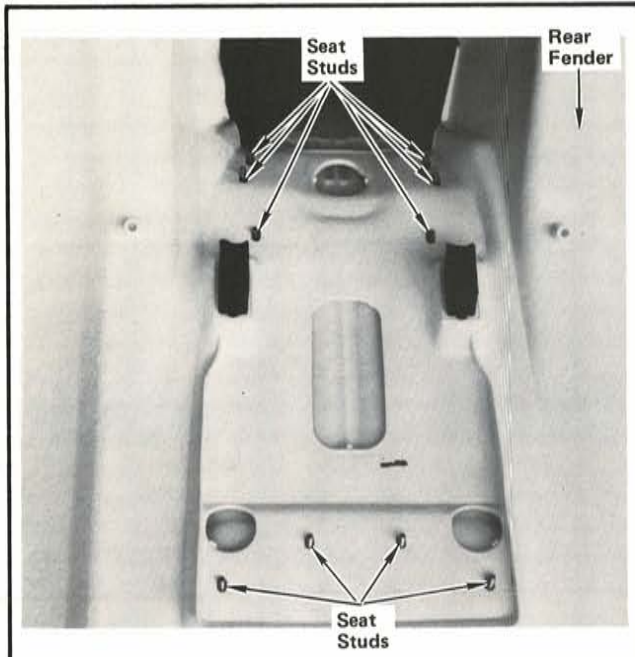

**STEP 47**—Place seat on top of rear fender, inserting the ten seat studs down through holes in rear fender as shown.

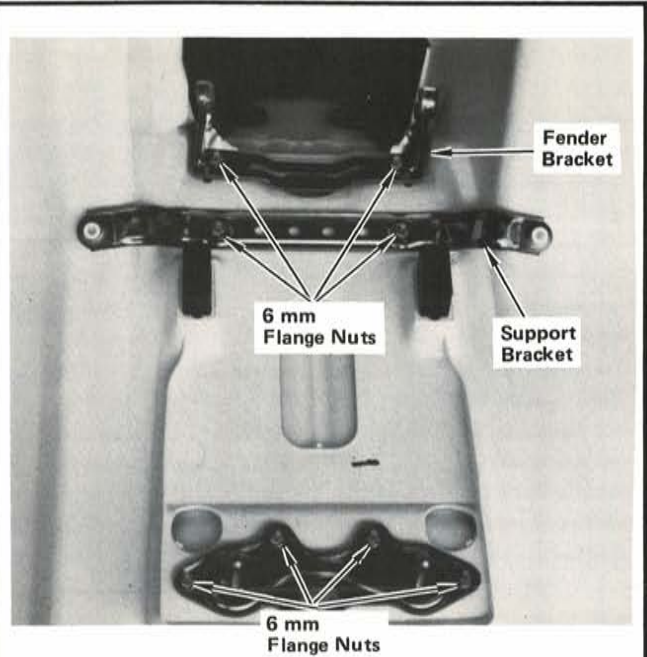

**STEP 48**—Position seat latch plate, fender brace, and seat hook bracket on studs under rear fender as shown. Install seat latch plate, fender brace, and seat hook bracket using a 6 mm flange nut on each stud. Tighten nuts securely.

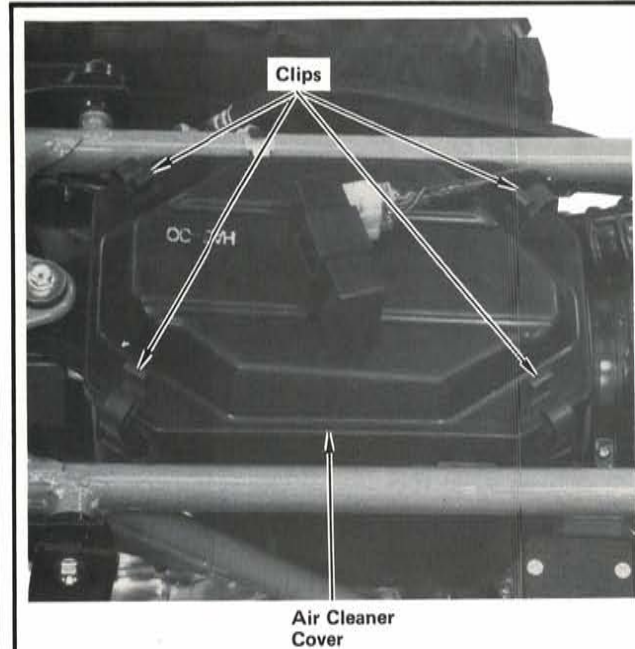

**STEP 49**—Remove air cleaner cover by releasing four clips.

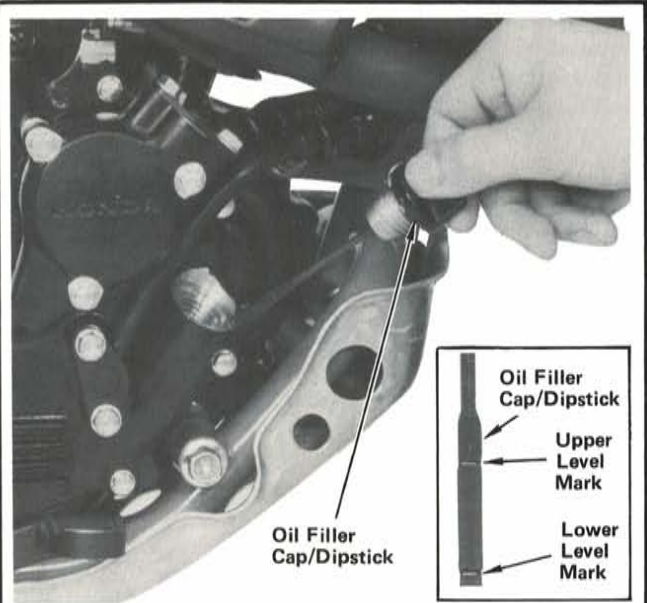

**STEP 50**—Remove oil filler cap/dipstick and fill crankcase with recommended oil as described in owner's manual or shop manual. Reinstall and tighten oil filler cap/dipstick.

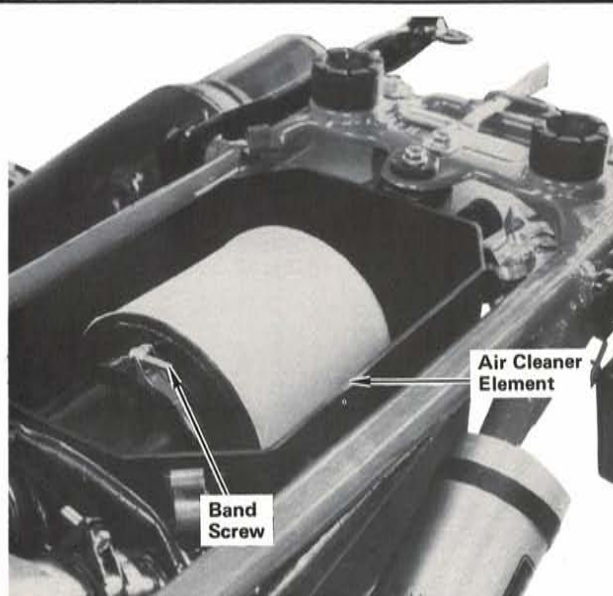

**STEP 51**—Loosen band screw and remove air cleaner element and holder. Check condition of element and clean if necessary as described in owner's manual or shop manual. Reinstall element and holder and tighten band screw securely. Reinstall air cleaner cover and reengage clips.

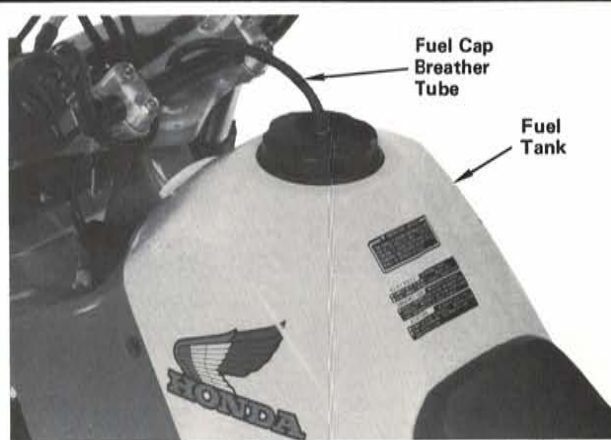

**STEP 52**—Drain fuel tank as described in shop manual. Remove, inspect, and flush fuel tank. Reinstall fuel tank, connect fuel line, fill tank, turn on fuel petcock and check for leaks and flow through fuel filter. Check that end of fuel cap breather tube is in hole in steering stem nut. Drain residual fuel from carburetor.

**WARNING** Fuel must be drained into a proper container. Gasoline is flammable and explosive under certain conditions. Do not smoke or allow flames or sparks near while draining fuel.

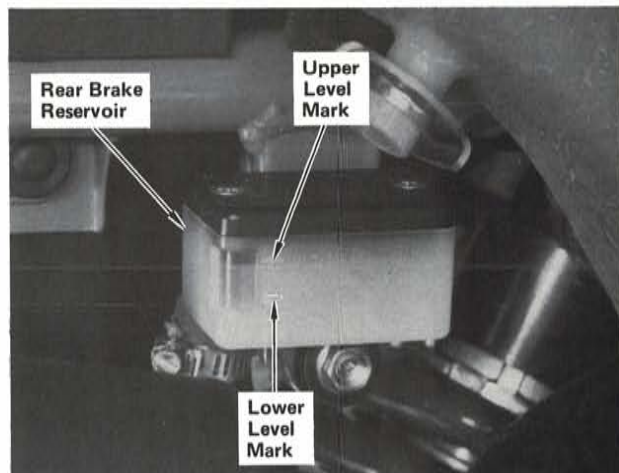
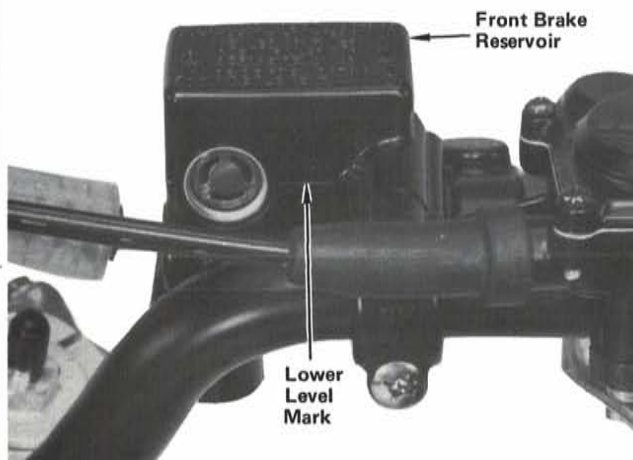

**STEP 53**—Check fluid level in front and rear brake reservoirs. If level is below upper level mark, remove cover and diaphragm and add DOT 3 or 4 brake fluid from a sealed container. Reinstall diaphragm and cover and tighten screws securely. Operate brake levers. If free play is excessive and reservoirs are filled to correct level, air is in the system. Bleed brake systems as described in shop manual.

**WARNING** Brake fluid can cause irritation. Avoid contact with skin or eyes.

**CAUTION:** Use only DOT 3 or 4 brake fluid from a sealed container. Handle brake fluid with care as it can damage painted surfaces and plastic components.

**NOTE:** The hydraulic disc type brakes require no free play adjustments.

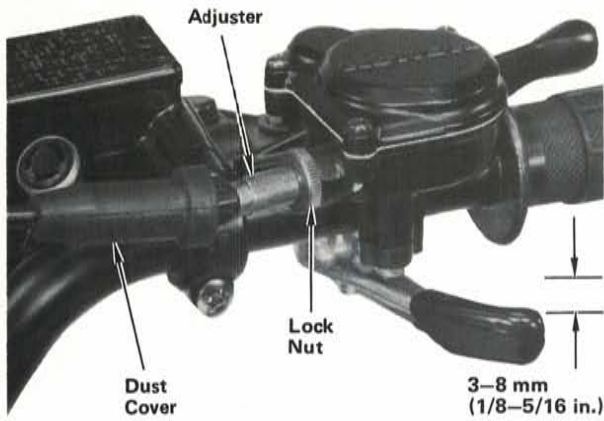

**STEP 54**—Check throttle cable condition. Check that throttle lever free play is within 3–8 mm (1/8–5/16 in.) at tip of throttle lever. Check for smooth operation of throttle lever from fully open to fully closed in all steering positions and that throttle lever automatically returns from fully open to fully closed when released. If necessary to adjust free play, slip off dust cover, loosen lock nut, and turn adjuster to obtain correct free play. After adjustment, tighten lock nut and reinstall dust cover.

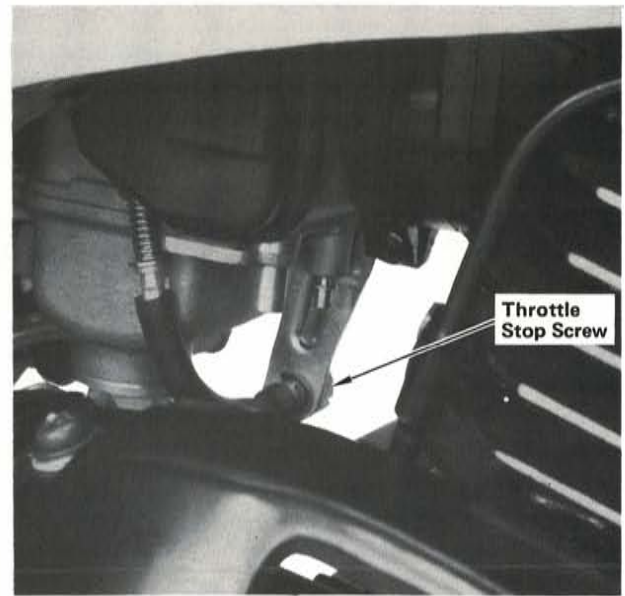

**STEP 55**—Connect a tachometer and check transmission in neutral. Start engine and allow it to warm up to operating temperature and check idle speed at 1,300 ± 100 rpm. If necessary, adjust idle speed using throttle stop screw. Remove tachometer.

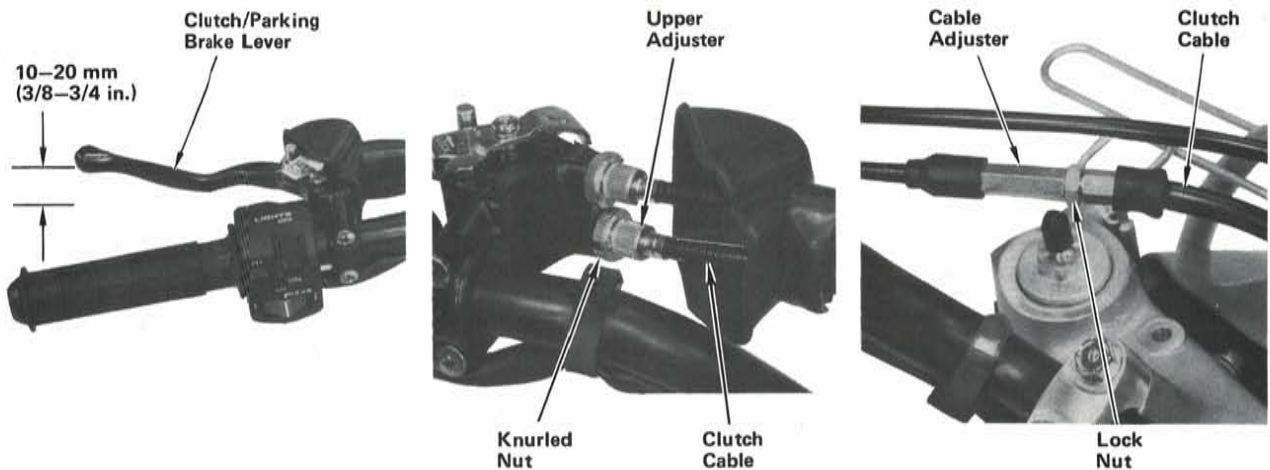

**STEP 56**—Check clutch lever free play at tip of clutch lever before clutch starts to disengage. Free play, measured at tip of clutch lever should be between 10 and 20 mm (3/8–3/4 in.). To adjust free play, loosen knurled nut and turn upper adjuster. If upper adjuster is turned out near its limit and correct free play cannot be obtained, screw upper adjuster all the way in and tighten knurled nut. Then use cable adjuster to obtain correct free play as follows. Loosen lock nut and turn cable adjuster to obtain correct free play. After adjustment, tighten lock nut.

**CAUTION:** After adjusting clutch lever free play, start engine, pull in clutch lever and shift into gear. Check that engine does not stall and vehicle does not creep. Gradually release clutch lever and open throttle, vehicle should start smoothly and accelerate gradually.

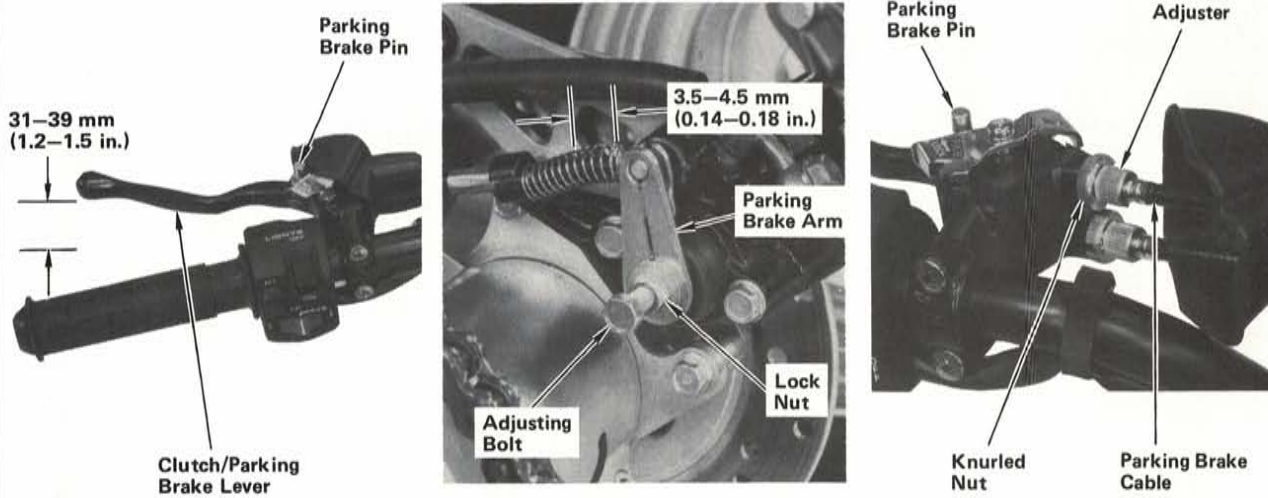

**STEP 57**—Check parking brake operation. Check that free play at tip of parking brake arm is 3.5–4.5 mm (0.14–0.18 in.). If adjustment is necessary, loosen lock nut on rear brake caliper and turn adjusting bolt until resistance is felt without squeezing clutch/parking brake lever. Tighten lock nut. Check that travel of clutch/parking brake hand lever is between 31 and 39 mm (1.2–1.5 in.) at tip of lever. If adjustment is necessary, loosen knurled nut, squeeze clutch/parking brake lever while pushing parking brake pin, and turn adjuster. Tighten lock nut and recheck brake arm free play at rear brake caliper. Install dust cover.

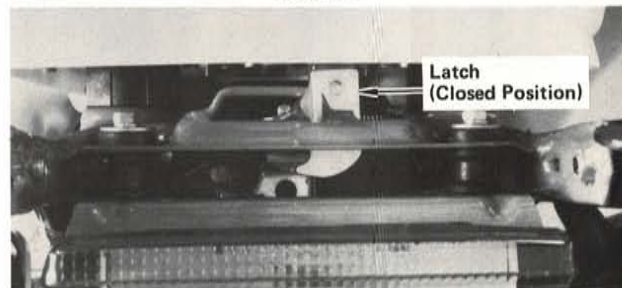
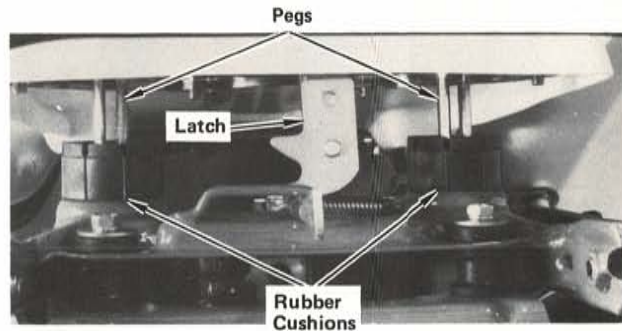
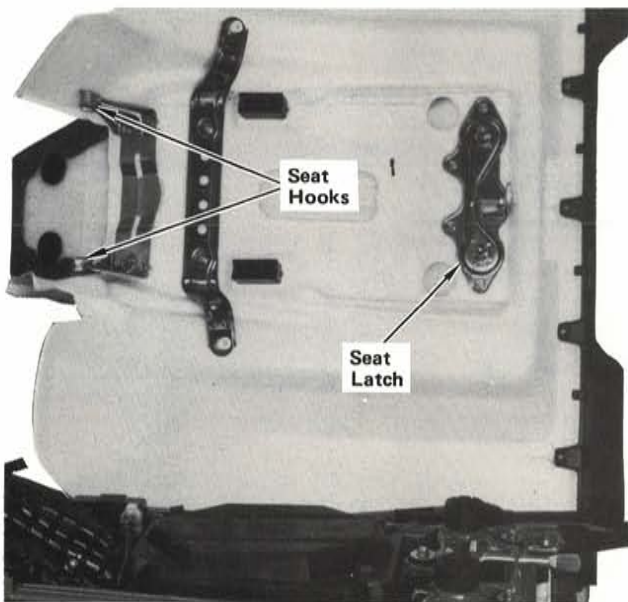

**STEP 58**—Install seat/rear fender by sliding seat hooks over seat mounts at rear of fuel tank and sliding seat forward. Align pegs of seat latch plate with holes in rubber cushions on frame. Press down on rear of seat until seat latch engages. Check that seat latch is fully engaged.

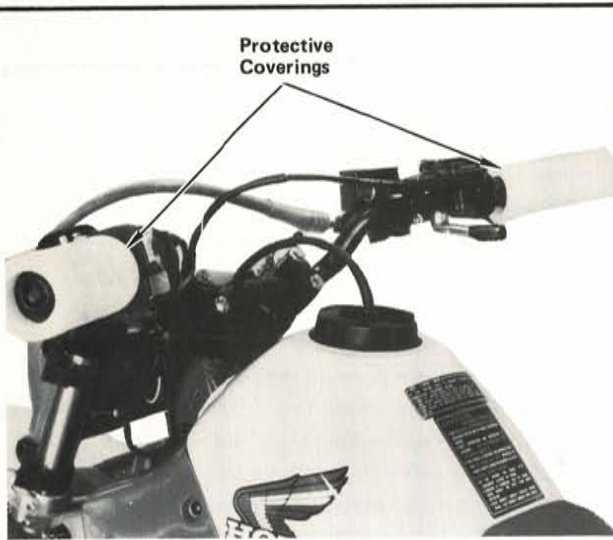

**STEP 59**—Remove protective coverings from handgrips.

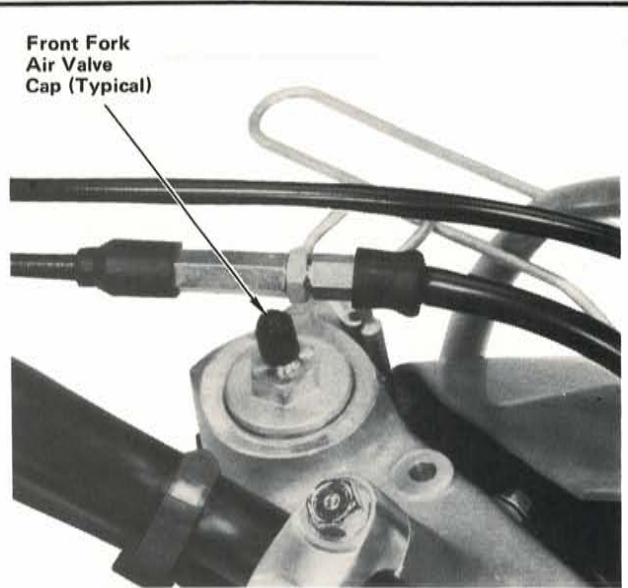

**STEP 60**—Remove front fork air valve caps and check front fork air pressure as described in owner's manual or shop manual. Reinstall air valve caps.

Standard air pressure: 0 psi.

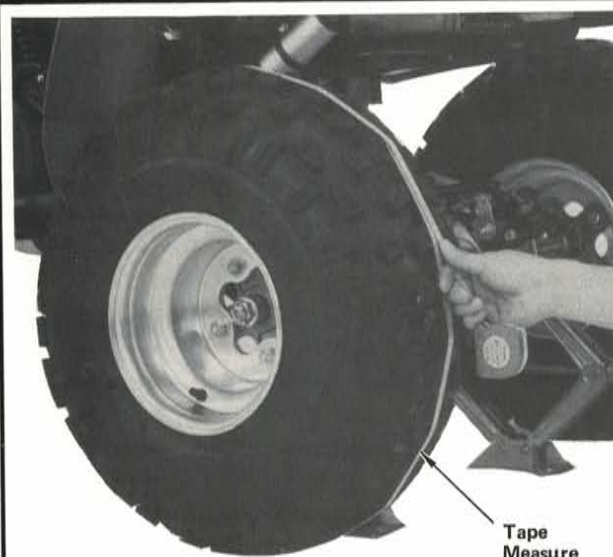

**STEP 61**—Check tire pressure and circumference.

*NOTE: Tire pressure should be checked when tires are cold.*

<b>Recommended tire pressure:</b>	<b>Standard circumference:</b>
Front: 4.0 psi.	Front: 1901 mm (74.8 in.)
Rear: 3.0 psi.	Rear: 1734 mm (68.3 in.)

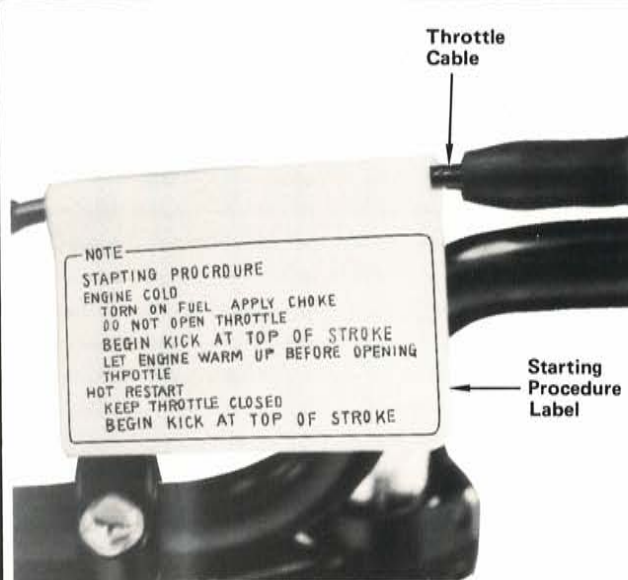

**STEP 62**—Attach starting procedure label to throttle cable as shown.

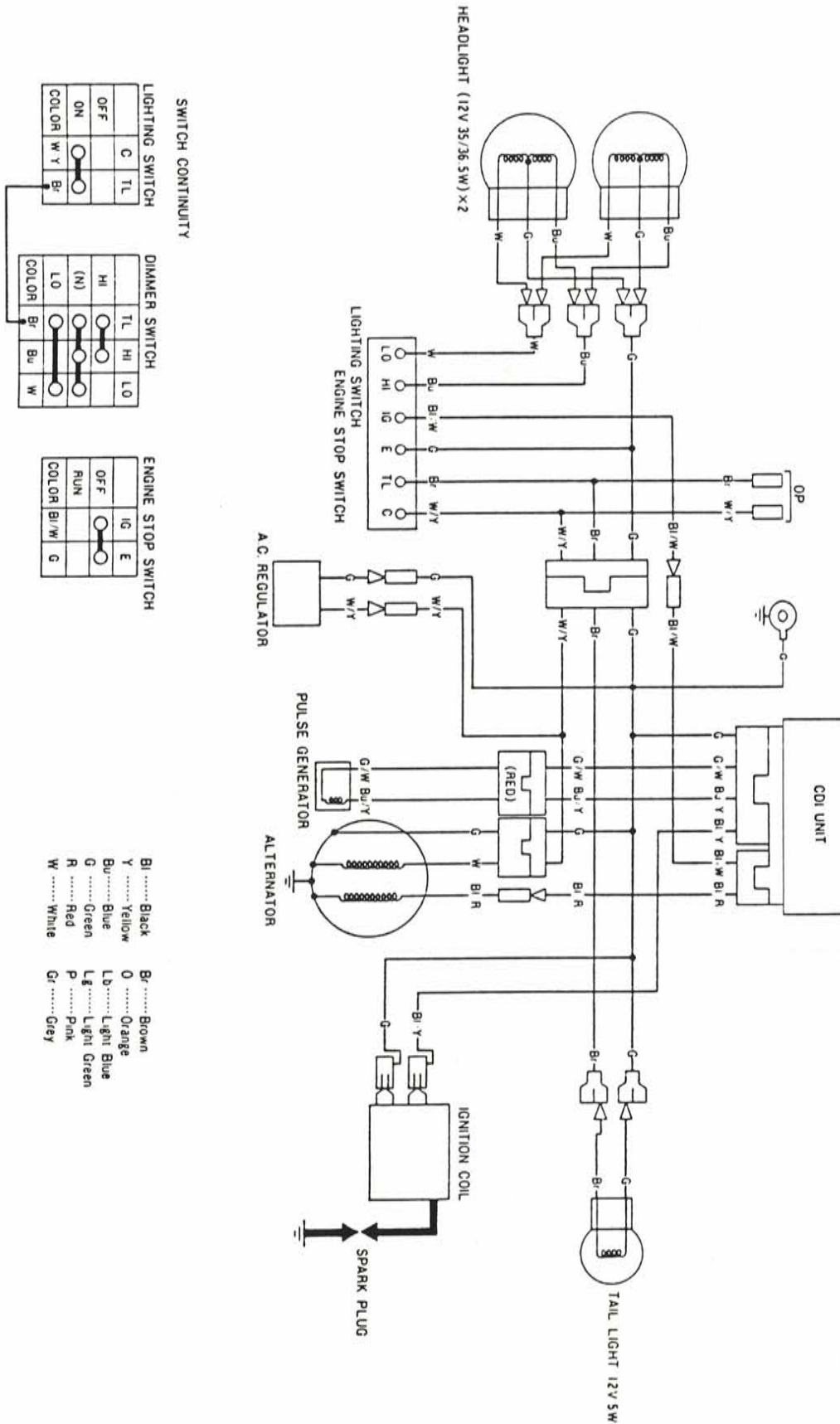



## TORQUE TABLE

ITEM	SIZE	TORQUE
Handlebar upper holder bolts	8 mm	2.4 kg-m (18 lb-ft)
Fork leg bolts	8 mm	2.1 kg-m (16 lb-ft)
Front axle	-----	6.0 kg-m (44 lb-ft)
Axle holder nuts	-----	1.2 kg-m ( 9 lb-ft)
Front brake caliper bolts	8 mm	2.5 kg-m (18 lb-ft)
Master cylinder holder screws	6 mm	0.9 kg-m ( 7 lb-ft)
Front brake hose guide bolts	8 mm	2.1 kg-m (16 lb-ft)
Front brake hose clamp bolts	6 mm	1.2 kg-m ( 9 lb-ft)
Front fender bolts	6 mm	1.2 kg-m ( 9 lb-ft)
Rear axle nuts	-----	14.5 kg-m (105 lb-ft)
Carrying handle bolts	8 mm	2.7 kg-m (19 lb-ft)
Skid plate bolts	8 mm	2.7 kg-m (19 lb-ft)
Seat nuts	6 mm	1.0 kg-m ( 8 lb-ft)

*NOTE: Check all items listed on the following Pre-delivery Service Check List. Refer to owner's manual or shop manual for specifications and detailed procedures. Always test ride the unit to make sure that it is functioning properly.*

## PRE-DELIVERY SERVICE CHECK LIST

- |  |  |
|--|--|
| <ul style="list-style-type: none"> <li><input type="checkbox"/> Fill front and rear brake master cylinder reservoirs with DOT 3 or DOT 4 brake fluid. Bleed brake systems if necessary.</li> <li><input type="checkbox"/> Adjust parking brake and check cable routing. Check front and rear brake operation and brake hose routing.</li> <li><input type="checkbox"/> Check crankcase oil level. If necessary, fill crankcase with recommended oil.</li> <li><input type="checkbox"/> Remove and inspect fuel tank, drain and flush. Clean fuel filter.</li> <li><input type="checkbox"/> Drain residual fuel from carburetor.</li> <li><input type="checkbox"/> Check air cleaner element. Oil if necessary.</li> <li><input type="checkbox"/> Adjust clutch, check cable routing and check operation.</li> <li><input type="checkbox"/> Reinstall fuel tank, fill, turn on petcock and check for leaks.</li> <li><input type="checkbox"/> Adjust idle speed.</li> <li><input type="checkbox"/> Check throttle lever free play, cable routing, and operation in all steering positions.</li> <li><input type="checkbox"/> Lubricate drive chain, if necessary.</li> <li><input type="checkbox"/> Check tire pressure.</li> <li><input type="checkbox"/> Check front fork air pressure.</li> <li><input type="checkbox"/> Check operation and adjustment of front and rear suspension.</li> </ul> | <ul style="list-style-type: none"> <li><input type="checkbox"/> Inspect electrical components for proper operation and adjustment.           <ul style="list-style-type: none"> <li>• Headlight: Adjust.</li> <li>• Taillight.</li> <li>• Engine stop switch.</li> </ul> </li> <li><input type="checkbox"/> Check security of all nuts, bolts and other fasteners.</li> <li><input type="checkbox"/> Check to ensure that all applicable recall and product update campaigns are complied with.</li> <li><input type="checkbox"/> <b>TEST RIDE:</b> Check performance, handling, and operation.           <ul style="list-style-type: none"> <li>• Transmission and clutch: Ease of shifting, clutch operation, etc.</li> <li>• Acceleration: Smoothness, etc.</li> <li>• Cruising: Smoothness, etc.</li> <li>• Handling: Stability and cornering.</li> <li>• Brakes: Smoothness and stopping power.</li> <li>• Idling: Smoothness, throttle response, and return to idle.</li> <li>• Recheck idle speed after 10 minutes of stop and go operation.</li> <li>• Parking brake operation: Check.</li> <li>• Upon completion of test ride, check for fuel and oil leaks.</li> </ul> </li> </ul> |
|--|--|

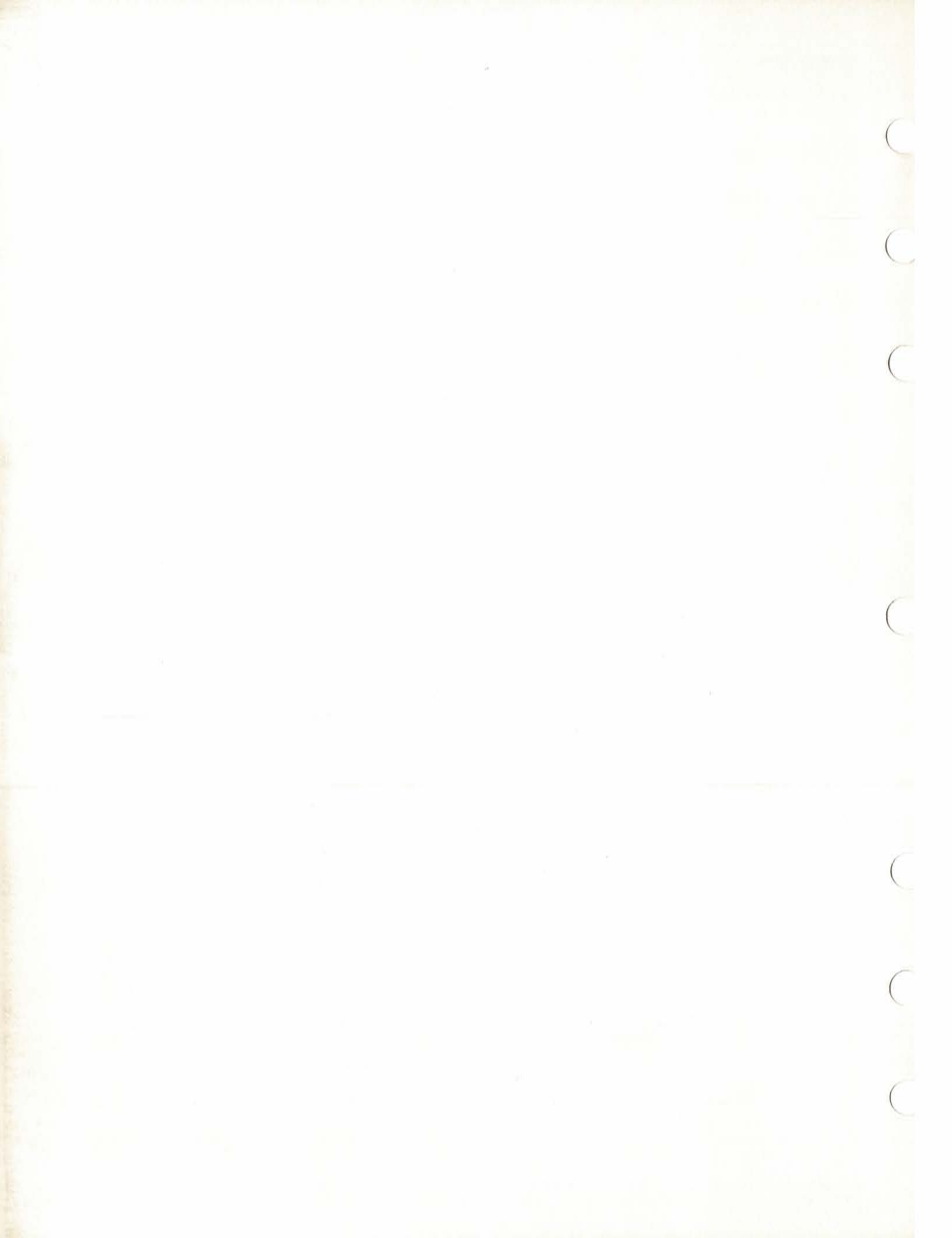



READ THIS READ THIS READ THIS

READ THIS READ THIS READ THIS

# HONDA

Modifications which you have made, or should make in the future, to any Honda product, shall be deemed by our company to have been performed at your sole risk and responsibility, and without our company's or the manufacturer's approval or consent, implied or expressed. We further disclaim any and all liability, obligation, or responsibility for any defects of modified parts or of the modified product, and for any claims, demands, or causes of action for damage to property or for personal injuries resulting from the modification of said Honda product.

READ THIS READ THIS READ THIS