

 **HONDA**

1985

Owner's Manual



ATC250R

HONDA ATC 250R
OWNER'S MANUAL

1985



All information in this publication is based on the latest product information available at the time of approval for printing. HONDA MOTOR CO., LTD. reserves the right to make changes at any time without notice and without incurring any obligation.

No part of this publication may be reproduced without written permission.

////////////////////// PREFACE //////////////////////////////////////

This booklet is your guide to the basic operation and proper maintenance of your new Honda ATC250R. Please take the time to read it carefully. Details necessary for riding the Honda ATC are given to acquaint the new owner with special riding techniques to be learned. When service is required, remember that your Honda dealer knows your vehicle best. If you have the required mechanical “know-how” and tools, your dealer can supply you with an official Honda Shop Manual to help you perform many maintenance and repair tasks.

Thank you for selecting a Honda. We wish you continued riding pleasure in the miles ahead.

WARNING

- * *The ATC 250R is a high performance machine, based on the latest motocross technology. It is intended for use by experienced riders only. Although it is a recreational vehicle, it is definitely NOT a toy.*

//////////////////// CONTENTS //////////////////////

	Page		Page
ATC SAFETY	1	Spark Plug	46
DESCRIPTION	4	Air Cleaner	47
Parts Location	4	Clutch	48
Serial Numbers	6	Brakes	50
Parts Function	7	Throttle Cable	54
Fuel	11	Drive Chain	55
Transmission Oil	14	Spark Arrester	57
Coolant	16	STORAGE	58
Tires	18	TRANSPORTING	59
Front Suspension	20	NOISE EMISSION CONTROL	63
Rear Suspension	21	SPECIFICATIONS	64
OPERATION	25	WIRING DIAGRAM	65
Pre-ride Inspection	25	PERIODIC REPLACEMENT PARTS	66
Starting the Engine	26	OPTIONAL PARTS	67
Break-in	28	WARRANTY SERVICE	72
Riding	29		
Parking	37		
MAINTENANCE	38		
Maintenance Schedule	38		
Tool Kit	41		
Fuel Filter	42		
Carburetor	43		

ATC SAFETY

Read these WARNING LABELS before you ride!

REMEMBER

- PRESERVE NATURE
- ALWAYS WEAR A HELMET
- RIDE SAFELY
- READ OWNER'S MANUAL CAREFULLY BEFORE RIDING



▲ WARNING

**OPERATOR ONLY
NO PASSENGERS**

▼ IMPORTANT NOTICE

THIS VEHICLE IS DESIGNED AND MANUFACTURED FOR OFF-THE-ROAD USE ONLY. IT DOES NOT CONFORM TO FEDERAL MOTOR VEHICLE SAFETY STANDARDS AND OPERATION ON PUBLIC STREETS, ROADS, OR HIGHWAYS IS ILLEGAL.

CAUTION

- DO NOT REMOVE RADIATOR CAP WHEN ENGINE IS HOT. ONLY REMOVE CAP WHEN DRAINING COOLANT.
- CHECK THE COOLING SYSTEM FREQUENTLY BY OBSERVING LEVEL IN THE RESERVE TANK. ADD NECESSARY COOLANT AT RESERVE TANK FILLER OPENING.
- USE A 50/50 SOLUTION OF ANTI-FREEZE AND WATER. USE ONLY ANTI-FREEZE OR SUMMER COOLANT RECOMMENDED FOR USE IN ALUMINUM ENGINES.
- USE SOFT WATER (HARD WATER OR SALT WATER IS HARMFUL TO ALUMINUM).
- REFER TO OWNER'S MANUAL FOR COMPLETE INFORMATION.

▼ IMPORTANT INFORMATION MODEL ATC250R

- COLD TIRE PRESSURE
FRONT: 4.3 psi (0.30 kg/cm²)
- TIRE: DUNLOP
FRONT: 23 x 8 - 11
REAR: 20 x 10 - 9
- VEHICLE CAPACITY LOAD: 270 lbs (120 kg)

▼ CAUTION DRIVE CHAIN

- CHECK THE SLACK AND LUBRICATION BEFORE OPERATION
- CHAIN SLACK 1.2 — 1.6 IN.
(30 — 40 mm)

WARNING

- * *ATC riding requires special efforts on your part to ensure your safety. Know these requirements before you ride.*

SAFE RIDING RULES

- * Always make a pre-ride inspection (page 25) before you ride the ATC. You may prevent an accident or equipment damage.
- * Always obey local off-road riding laws and regulations.
- * Obtain permission to ride on private property. Avoid posted areas and obey "no trespassing" signs.
- * Know the terrain on which you are riding. If you are not familiar with the terrain, ride cautiously. Hidden rocks, holes or ravines could spell disaster.
- * Your ability to operate safely is largely dependent upon your proper judgement in operating the machine.

PROTECTIVE APPAREL

- * Always wear a helmet. You should also wear a face shield or goggles, boots, gloves and protective clothing.
- * The exhaust system becomes very hot during operation and it remains hot after operation. Never touch any part of the hot exhaust system. Wear clothing that fully covers your legs.

MODIFICATIONS

- * *Modification of the ATC, or removal of original equipment may render the vehicle unsafe or illegal.*
- * Spark arresters and mufflers are required in most areas. Don't modify your exhaust system. Remember that excessive noise bothers everyone and creates a bad image for off-road vehicles.

DESCRIPTION

PARTS LOCATION

- (1) Fuel tank cap
- (2) Throttle lever
- (3) Front brake lever
- (4) Kick starter pedal
- (5) Footpeg
- (6) Rear brake pedal
- (7) Oil filler cap

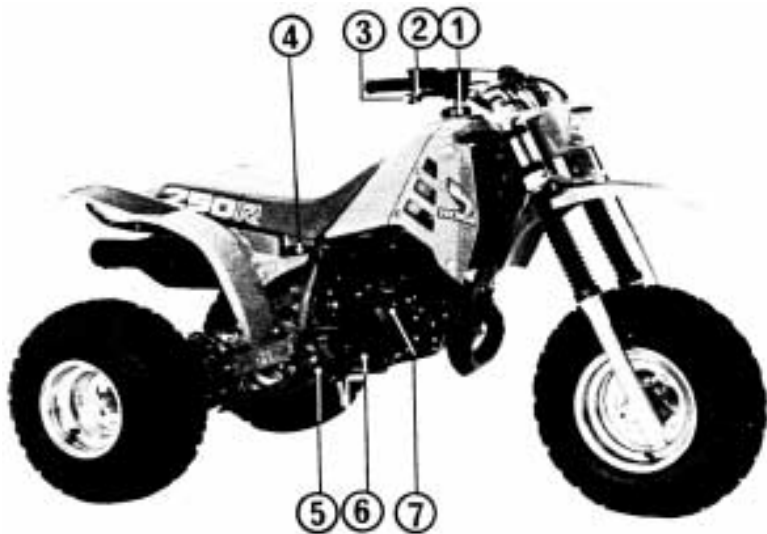

- (8) Headlight switch
- (9) Engine stop switch
- (10) Clutch lever/parking brake arm assy
- (11) Gearshift pedal
- (12) Choke lever
- (13) Fuel valve



SERIAL NUMBERS

The frame and engine serial numbers are required by your dealer when ordering replacement parts. Record the numbers here for your reference.

FRAME NO. _____

The frame serial number (1) is stamped on the left side of the steering head. The engine serial number (2) is stamped on the crankcase just above the left foot peg.

ENGINE NO. _____

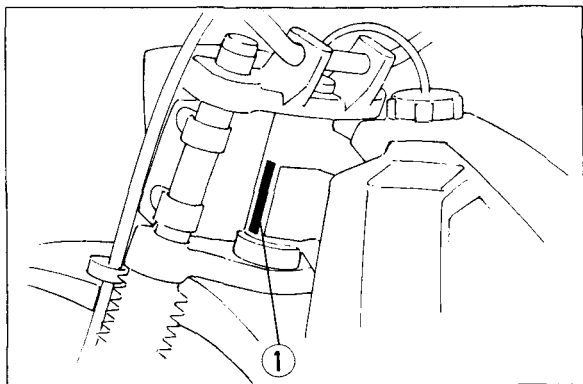

(1) Frame serial number

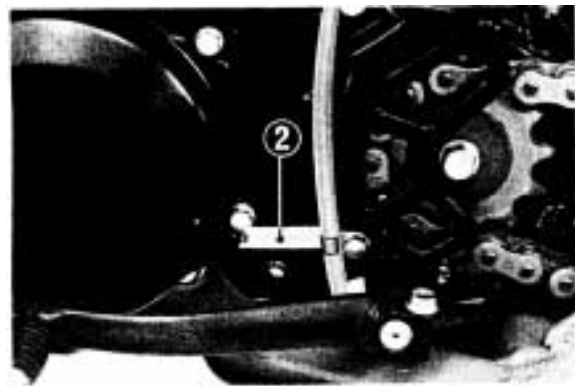

(2) Engine serial number

PARTS FUNCTION

Engine Stop Switch

The three position engine stop switch (1) is under the headlight switch. When the switch is in the RUN position, the engine will operate. When the switch is in either OFF position, the engine will not operate.

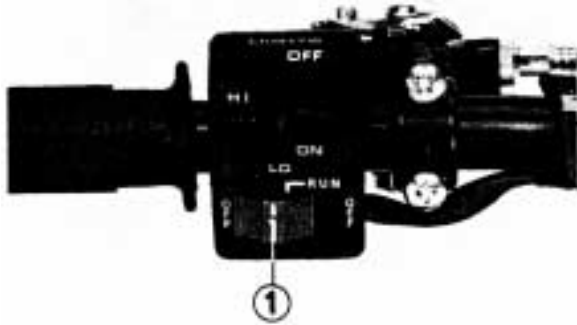

(1) Engine stop switch

Headlight Switch

The headlight switch (2) above the engine stop switch and turns the headlight ON or OFF.

Headlight Dimmer Switch

With the headlight switch (2) ON, use the dimmer switch (3) to select Hi for high beam or Lo for low beam.

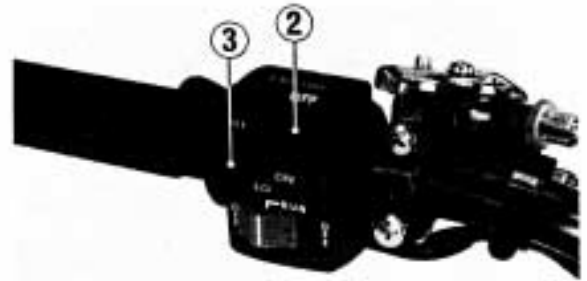

(2) Headlight switch (3) Headlight dimmer switch

Parking Brake

The clutch lever also functions as the parking brake lever.

To apply the parking brake, push down the parking brake arm pin (2), squeeze the clutch lever (1) and lock it with the lock (3). Always apply the parking brake when parking the ATC or starting the engine. To release the parking brake, squeeze the clutch lever (1) so the lock (3) automatically retracts.

NOTE:

* Use of the parking brake in freezing weather may cause the rear brake parking linkage to freeze in the locked position.

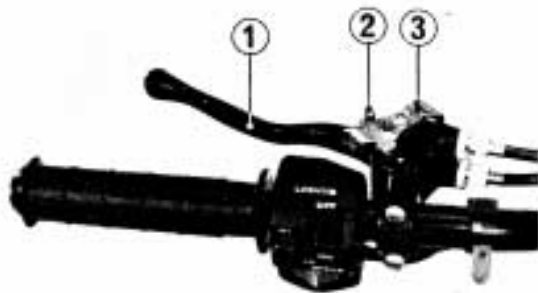

(1) Clutch lever

(2) Parking brake arm pin

(3) Lock

Front Brake

The front brake lever (1) is on the right handlebar. To stop the ATC, apply both front and rear brakes evenly, with the front wheel aimed straight ahead.

Throttle Lever

The throttle lever (2) is next to the right handlebar grip and is operated by the rider's thumb. Pressing the lever forward opens the throttle. When the lever is released, spring tension closes the throttle automatically.

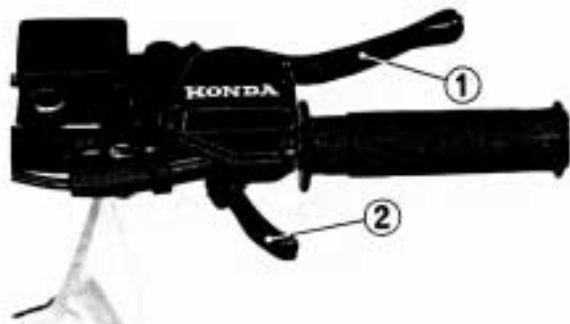

(1) Front brake lever

(2) Throttle lever

Rear Brake

The rear brake pedal (1) is near the right footpeg.

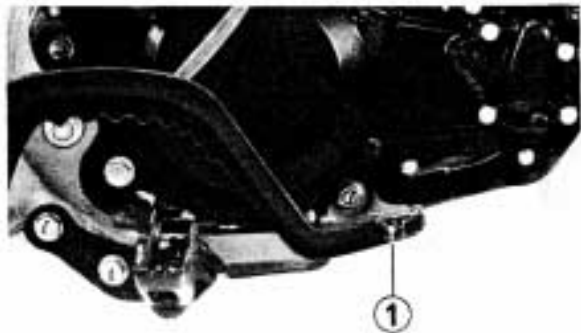

(1) Rear brake pedal

Gearshift Pedal

The gearshift pedal (2) is near the left footpeg.
Depress the pedal to shift to a lower gear and raise the pedal to shift to a higher gear.

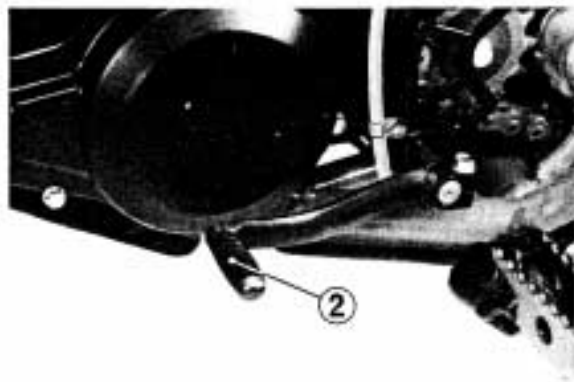

(2) Gearshift pedal

Starter Valve Lever

The starter valve lever (1) is on the left side of the carburetor. Lower the lever to position (A) opens the starter valve which allows the carburetor to deliver a rich mixture for starting the engine when cold. Raise the lever to position (B) as the engine attains normal operating temperature.

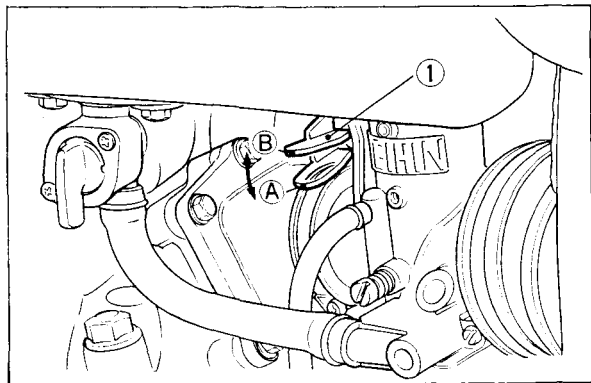

(1) Starter valve lever

FUEL

Fuel mixture

The ATC 250R has a two-stroke engine that requires a gasoline-oil mixture. Any premium, leaded gasoline with a research octane number between 92 and 100 may be used. If “knocking” or “pinging” occurs, try a different brand of gasoline or a higher octane grade.

USE HONDA 2-stroke oil or equivalent. Premix gasoline and oil in a ratio of 20 parts gasoline to one part oil (20:1). Prepare the fuel mixture in a clean container, and shake until thoroughly mixed before filling the fuel tank.

CAUTION:

** Too much oil will cause excessive smoking and spark plug fouling. Too little oil will cause engine damage or premature wear.*

NOTE:

- * Vegetable oils separate from gasoline more easily than mineral oils, especially in cold weather. It is advisable to use mineral oil when ambient temperatures of below 0°C (32°F) are expected.
- * If the gasoline-oil mixture is left standing in a container for a long period of time, lubricity will deteriorate; try to pre-mix only as much as you will use per riding day.

Fuel Valve

The three way fuel valve (1) is on the left side of the fuel tank.

OFF

When the fuel valve is in the OFF position, fuel cannot flow from the tank to the carburetor. Turn the valve off whenever the ATC is not in use.

ON

When the fuel valve is in the ON position, fuel will flow from the main fuel supply to the carburetor.

RES

When the fuel valve is in RES position, fuel will flow from the reserve fuel supply to the carburetor. Use the reserve fuel only when the main supply is gone. Refill the tank as soon as possible after switching to RES. The reserve fuel supply is 2.0 l (0.52 US gal, 0.43 Imp. gal).

NOTE:

- * Do not operate the machine with the fuel valve in the RES position after refueling. You may run out of fuel, with no reserve.

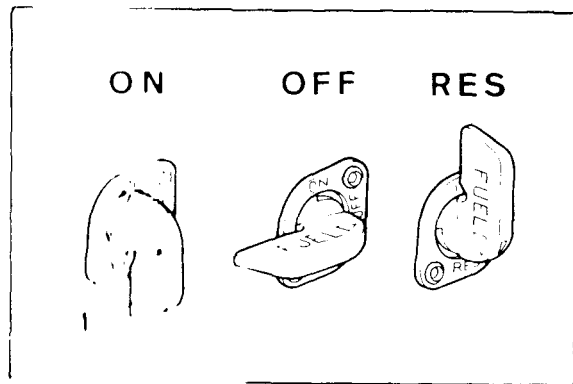

(1) Fuel valve

Fuel Tank

Fuel tank capacity is 9.8 ℓ (2.6 US gal, 2.2 Imp. gal) including 2.0 ℓ (0.52 US gal, 0.43 Imp. gal) in the reserve supply.

To open the fuel tank cap (1), pull out the breather tube (2) from the steering stem nut. Then turn the fuel tank cap counterclockwise.

After refueling, be sure to tighten the fuel cap firmly by turning it clockwise.

Insert the breather tube into the steering stem nut.

WARNING

- * *Gasoline is extremely flammable and is explosive under certain conditions. Refuel in a well ventilated area with the engine stopped. Do not smoke or allow open flames or sparks in the area where the vehicle is refueled or where gasoline is stored.*
- * *Avoid repeated or prolonged contact with skin or breathing of vapor. KEEP OUT OF REACH OF CHILDREN.*
- * *Do not overfill the tank (there should be no fuel in the filler neck). After refueling, make sure the tank cap is closed securely.*

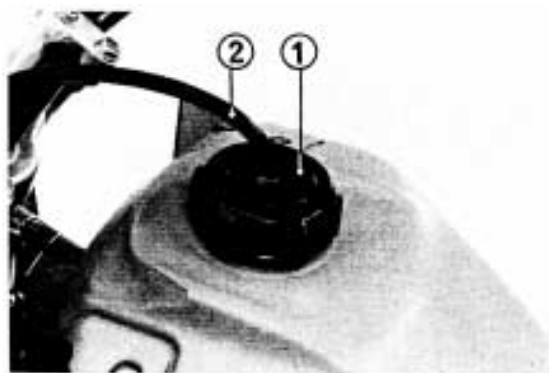

(1) Fuel tank cap

(2) Breather tube

TRANSMISSION OIL

Transmission oil level

To check the oil level and add oil:

1. With the engine off and the ATC on level ground, remove the oil check bolt (1) at the right crankcase.
2. The oil should flow out of the oil check bolt hole. After checking, tighten the oil check bolt securely.
3. If the oil does not flow out, add oil slowly through the oil filler hole (2) until the oil starts to flow out of the oil check bolt hole.

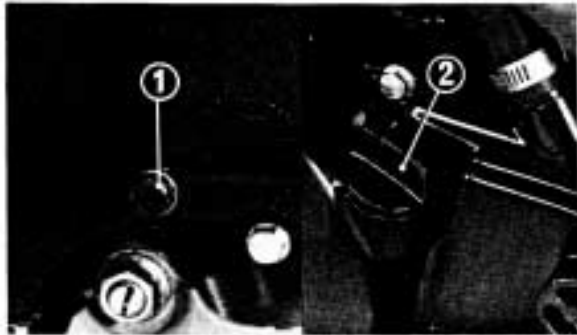

(1) Oil check bolt (2) Oil filler cap

Transmission oil change

1. Park the ATC250R on level ground and warm up the engine for a few minutes.
2. Stop the engine and remove the oil filler cap (2) and oil drain bolt (3).
3. After the transmission oil has drained completely, reinstall the drain bolt and pour in oil through the oil filler hole.

Transmission oil quantity:

0.7 ℓ (0.74 US qt, 0.62 Imp. qt) after disassembly

0.61 ℓ (0.64 US qt, 0.54 Imp. qt) at oil change

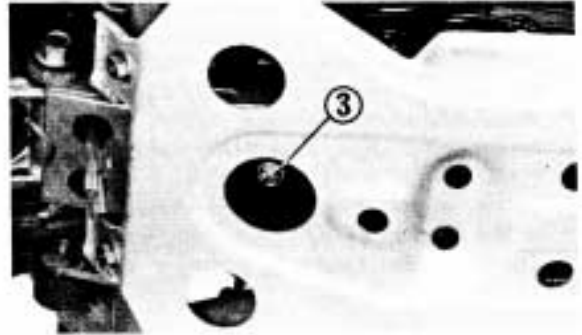

(3) Oil drain bolt

Transmission Oil Recommendation

USE HONDA 4-STROKE OIL OR AN EQUIVALENT.

Use only high detergent, premium quality motor oil certified to meet or exceed US automobile manufacturers' requirements for Service Classification SE or SF.

Motor oils intended for Service SE or SF will show this designation on the container. The use of special oil additives is unnecessary and will only increase operating expenses.

CAUTION:

- * *Oil is a major factor affecting the performance and service life of the transmission. Non-detergent, vegetable, or castor based racing oils, are not recommended.*

Recommended Oil Viscosity: SAE 10W-40

Other viscosities shown in the chart below may be used when the average temperature in your riding area is within the indicated range.

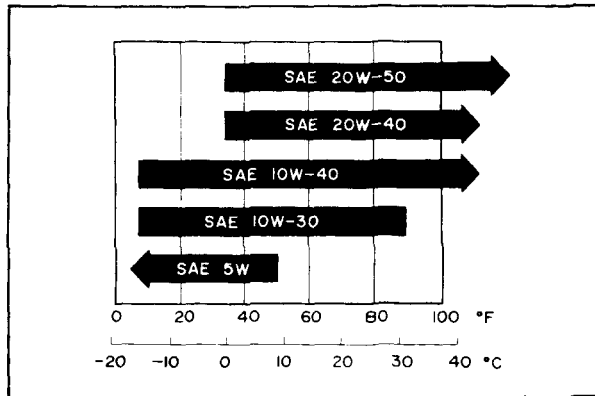

COOLANT

Coolant Recommendation

The owner must properly maintain the coolant to prevent freezing, overheating and corrosion. Use only high quality ethylene glycol antifreeze containing corrosion protection inhibitors specifically recommended for use in aluminum engines. (See ANTI-FREEZE CONTAINER LABEL.)

CAUTION

* *Use only low-mineral drinking water or distilled water as a part of the antifreeze solution. Water that is high in mineral content or salt may be harmful to the aluminum engine.*

The factory provides as a 50/50 solution of anti-freeze and water in this ATC 250R.

Inspection

The reserve tank is behind the right side cover. Check the coolant level in the reserve tank (1) while the engine is at the normal operating temperature. If the coolant level is low, remove the reserve tank cap (2) and add coolant mixture until it reaches the UPPER level mark. Do not remove the radiator cap.

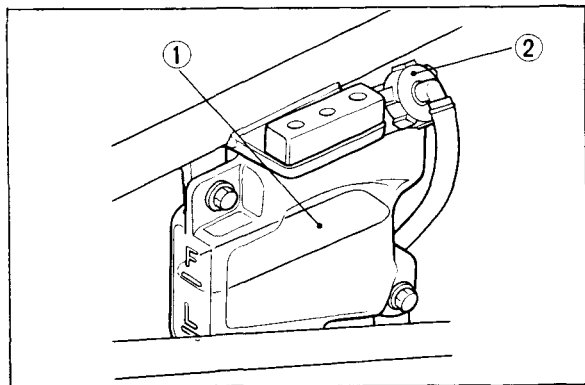

(1) Reserve tank

(2) Reserve tank cap

 **WARNING**

- * *Do not remove the radiator cap when the engine is hot. The coolant is under pressure and severe scalding could result. Only remove cap when drain coolant.*

If the reserve tank is empty, or if coolant loss is excessive, check for leaks and see your authorized dealer for repair.

TIRES

The ATC250R is equipped with low pressure tubeless tires to promote comfortable riding. Although the tires are designed specifically for vigorous off-road use, they are not immune to punctures. Always select your riding area with care.

WARNING

* *The ATC is not designed to be ridden on paved surfaces. Handling and control will be severely affected.*

For normal use, the tires should be inflated to a recommended pressure. A manually operated tire pump should be used rather than the high pressure systems found in service stations. This will minimize the possibility of tire damage from overinflation.

NOTE:

* Tire pressure should be checked when the tires are "cold," before you ride.

If no air pressure gauge is available to accurately measure a recommended pressure, this value can be estimated by measuring the circumference of the tires with a measuring tape. When inflated to a recommended pressure, the maximum tire circumference measured over the tread ribs will be approximately standard tire circumference. The relationship between tire pressure and actual circumference varies slightly with factors of wear and stretching that occur

through use.

	Recommended pressure	Min. pressure	Max. pressure	Standard tire circumference
Front	4.3 psi (30 kPa, 0.3kg/cm ²)	3.8 psi (27 kPa, 0.27kg/cm ²)	4.6 psi (33 kPa, 0.33kg/cm ²)	1837 mm (72.3 in)
Rear	3.6 psi (25 kPa, 0.25kg/cm ²)	3.1 psi (22 kPa, 0.22kg/cm ²)	3.9 psi (28 kPa, 0.28kg/cm ²)	1618 mm (63.7 in)

Tire Size

Front: 23 x 8-11

Rear: 20 x 10-9



 **WARNING**

- * *Maintain proper tire air pressure. Improperly inflated tires may adversely affect maneuverability and may cause loss of control.*

If you have a flat tire, use the plug method to make temporary repairs. The plug method is the same as that for conventional tubeless tires. A plug type repair kit, which is available at most auto part stores or service stations, provides a plug, an installation tool, tire cement, and an instruction sheet. Follow the instructions provided in the repair kit to make a temporary repair until the tire can be permanently repaired by the cold patch method. Any tire which cannot be repaired by the plug method should be replaced.

Whenever the ATC is to be operated far from service facilities or available transportation, we recommend that the rider carry a tire pump and a suitable repair kit.

Emergency Puncture Repairs

If you have a flat tire, and a plug type repair kit is not available, use one of the following methods to make temporary repairs: Stuff a narrow strip of cloth kneaded with chewing gum into the hole or plug the hole with a nail or screw.

NOTE:

- * **Do not use soapy water, oil or other such substances when installing a tire on the rim.**

FRONT SUSPENSION

The front suspension system uses air assisted front forks. The forks may be adjusted for the rider's weight and riding conditions by adjusting the air pressure.

Air pressure adjustment

Low air pressure settings provide a soft ride and are for light loads and smooth riding conditions.

High air pressure settings provide a firm ride and are for heavy loads and rough riding conditions.

Check and adjust air pressure when the fork tubes are cold and with the front wheel off the ground, for accurate pressure readings.

1. Place a support under the engine to raise the front wheel off the ground.
2. Remove the air valve caps (1) and check the air pressure with a pressure gauge (2).

Standard air pressure: 0 psi (0 kPa, 0 kg/cm²)

Depress the valve core to decrease air pressure.

3. If air pressure is insufficient, add air with a bicycle air pump.

Some pressure will be lost when using the gauge. Determine the amount of loss and compensate accordingly.

Also, be sure that the air pressure in both fork tubes is equal.

NOTE:

- * Use of more than 10 psi (70 kPa, 0.7 kg/cm²) is not recommended because fork action becomes very stiff.

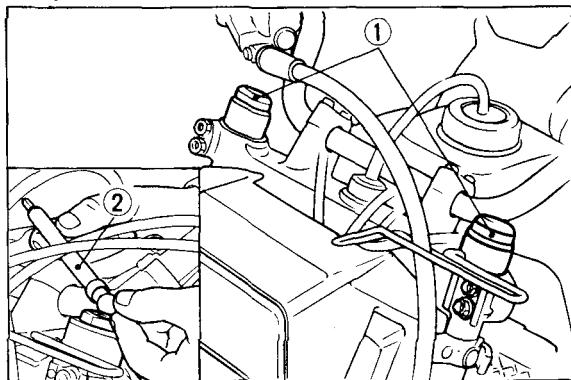

(1) Air valve caps

(2) Pressure gauge

REAR SUSPENSION

The ATC250R's shock absorber has three adjustments: spring preload, rebound damping and compression damping. In addition, the lower shock absorber mount utilizes the Pro-Link system to deliver true progressive springing and damping rates. Through these features, the shock can be adjusted to suit the rider's weight and riding conditions.

NOTE:

* All three adjustments should be made together, according to the sequence shown on pages 20 through 22.

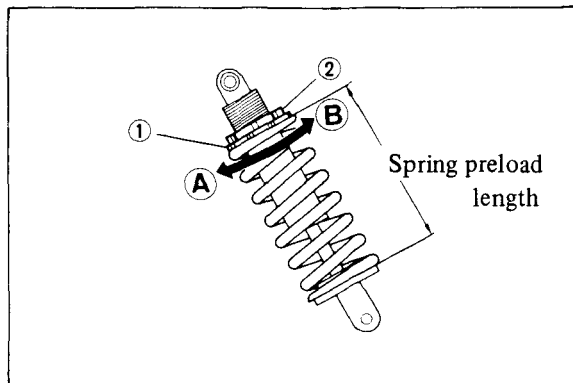

- (1) Adjust nut
- (2) Lock nut

- (A) Increase
- (B) Decrease

To adjust spring preload:

1. Remove the seat/rear fender by pushing the lever.
2. Place a support under the engine to raise the rear wheels off the ground.
3. Measure the spring preload length and if necessary, adjust it to the standard spring preload length.

STANDARD SPRING PRELOAD LENGTH:

242 mm (9.5 in)

To adjust preload, loosen the lock nut (2) with a pin spanner and turn the adjuster nut (1).

NOTE:

- * An optional pin spanner for adjusting rear shock preload is available at your authorized Honda dealer.

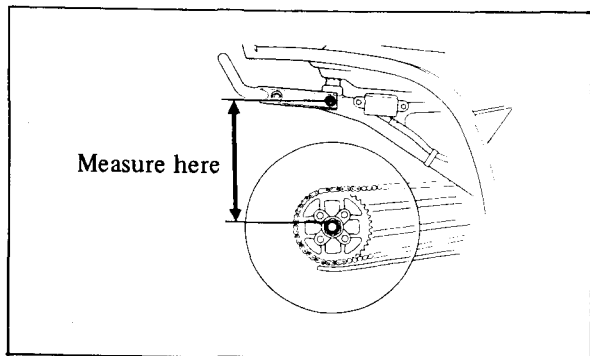

4. Temporarily reinstall the seat/rear fender. With the rear wheels still off the ground, measure from the rear axle to the center of bolt attaching rear carrier. Now remove the support and let the ATC rest on the ground.
5. Sit on the ATC and have someone remeasure the distance from the rear axle to the center of bolt attaching rear carrier to the frame, just as you did in step 4.
6. The difference between the two measurements should be 85 mm (3.3 in). Adjust the spring preload length, as required, to achieve this figure. But do not exceed the minimum or maximum spring preload lengths.

MINIMUM SPRING PRELOAD LENGTH:

236.7 mm (9.3 in)

MAXIMUM SPRING PRELOAD LENGTH:

248.5 mm (9.7 in)

7. Tighten the shock lock nut securely. Then, reinstall the seat/rear fender, making sure that it is attached securely.

To adjust rebound damping:

The rebound damping adjuster is located at the right bottom of the shock absorber.

To adjust, turn the rebound damping adjuster (3) to the desired position, and test ride to see if adjustment is necessary. See page 22.



(3) Rebound damping adjuster

To adjust compression damping:

The compression damping adjuster (4) is located on the shock reservoir and has a punch mark on its outer surface. When the punch mark is aligned between the "S" (Soft) and "H" (Hard) marks on the reservoir body, the compression damping is in the standard position.

It is best to start with the adjuster in the standard position and test ride to see if adjustment is necessary. See page 22.

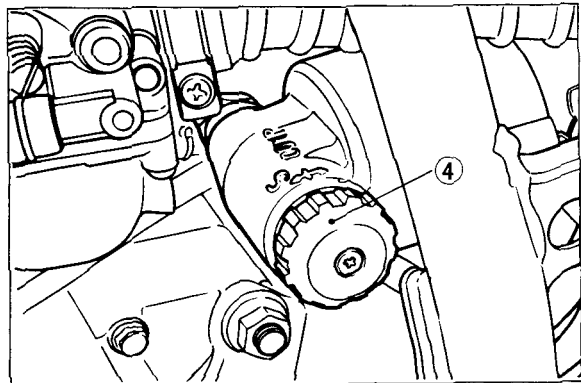

(4) Compression damping adjuster

Condition and adjustment

- Always start with Step 1 and then go through Step 2 to Step 3.
- Return to Step 1 and repeat Step 1 through Step 3.

Step Condition	1	2	3
Bottoming	Shorten the spring length (to increase the pre-load).	Turn the compression adjuster to stiffer position (to increase the damping force).	
Soft	Turn the compression adjuster to a stiffer position (to increase the damping force).	Shorten the spring length (to increase pre-load).	Turn the tension adjuster to a stiffer position (to increase the damping force).
Hard	Turn the compression adjuster to soft.	Increase the spring length (to decrease pre-load).	
Excessive sinking	Shorten the spring length (to increase the pre-load).		

WARNING

- * *The rear shock absorber damper body contains pressurized nitrogen gas at 185 psi (1,300 kPa, 13 kg/cm²). Do not attempt to disassemble the shock body. See your authorized Honda dealer for shock absorber service.*
- * *Do not disconnect the reservoir hose or disassemble and refill the reservoir.*
- * *Keep fire and heat away from the shock and its reservoir.*
- * *If replacement is necessary, take the used shock absorber to your authorized Honda dealer for proper disposal.*

PRE-RIDE INSPECTION

WARNING

* *If the Pre-ride Inspection is not performed, serious damage or an accident may result.*

Inspect your ATC 250R every day before you ride it. The items listed here will only take a few minutes, and in the long run they can save time, expense, and possibly your life.

1. Fuel level-fill fuel tank when necessary (page 11).
Check for leaks.
2. Coolant level – add coolant if required.
– check for leaks (page 14).
3. Brakes-check operation and fluid level (page 50 – 53).
4. Tires-check condition and pressure (page 18).
5. Drive chain-check condition and slack (page 55).
Adjust and lubricate if necessary (particularly the master link).
6. Throttle-check for smooth opening and closing in all steering positions (page 54).
7. Headlight switch-check for proper function (page 5).
8. Ignition switch-check for proper function (page 5).

9. Nuts, bolts, fasteners-check wheels to see that axle nuts are tightened and secured by cotter pins. Check security of all other nuts, bolts and fasteners.

Correct any discrepancy before you ride. Contact your authorized Honda dealer for assistance if you cannot correct the problem.

STARTING THE ENGINE

WARNING

- * *Never run the engine in a closed area. The exhaust contains poisonous carbon monoxide gas.*
- * *Do not try to start the engine with the transmission in gear. You may injure yourself or damage the vehicle.*

Preparation

Select a level surface and set the parking brake before starting the engine.

Starting Procedure

Cold engine starting

1. Turn the fuel valve ON.
2. Move the engine stop (1) to RUN.
3. Make sure that the transmission is in neutral.

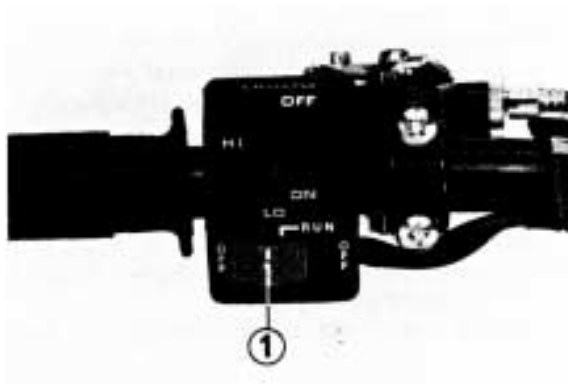

(1) Engine stop switch

4. Lower the starter valve lever (2) to (A).
5. With the throttle (3) closed, operate the kick starter (4) with a rapid, continuous motion.
6. After the engine starts, run it for a few minutes, "blipping" the throttle until it warms up enough to idle with the starter valve lever raised (B). The lever should be raised as soon as possible to prevent spark plug fouling.

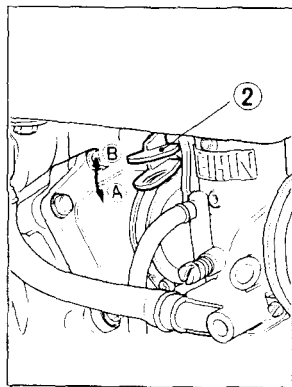

(2) Starter valve lever
(A) Open (B) Close



(3) Throttle lever

Warm engine starting

1. Follow the cold engine starting procedure without lowering the starter valve lever and with the throttle opened slightly (1/8–1/4).

CAUTION:

- * Do not race the engine during the warm-up period. Racing a cold engine wastes fuel and increases engine wear.

NOTE:

- * You can restart the engine with the transmission in gear by holding in the clutch lever while operating the kickstarter.



(4) Kick starter

BREAK-IN

Engine life and power output can be significantly increased by following a few simple rules during the 5 hour engine break-in period. Refer to the chart and procedures given here.

BREAK-IN PERIOD	
FIRST HOUR	SECOND TO 5TH HOUR
0 to 1/2 throttle	Do not use full throttle for more than 3 seconds

You should operate the ATC 250R as follows during the break-in period.

1. After operating the ATC for half an hour, shut the engine off to cool for at least 10 minutes.
2. Do not operate the engine at full power during the break-in period for more than the recommended time.
3. Do not lug the engine or ride at one constant speed. Vary your throttle settings.
4. Avoid climbing hills or riding through deep snow or sand.
5. Run the engine only at the recommended ratio of 20 parts gasoline to 1 part oil (20 : 1).

CAUTION:

Severe engine damage may result if these break-in procedures are not followed.

RIDING

WARNING

- * *Review ATC Safety (page 2) before you ride.*
- * *Ride with both feet on the footpegs at all times. If your feet are off the pegs and touching the ground while the ATC is moving, they may come in contact with the rear wheels, causing injury.*
- * *Avoid “wheelies” and “jumping” as they may cause loss of control.*
- * *The ATC is not designed to be ridden on paved surfaces. Handling and control will be severely affected.*

For your initial riding practice, select a safe area free of obstacles and with an even surface.

1. After the engine has been warmed up, release the parking brake. The machine is ready for riding.
2. While the engine is idling, pull in the clutch lever and depress the **gearshift** pedal to shift into low (1st) gear.
3. Increase engine speed by opening the throttle; gradually release the clutch lever.
4. When the speed increases, close the throttle, pull in the clutch lever, and shift to 2nd gear by raising the **gearshift** pedal.

5. This sequence is repeated to progressively shift to 3rd, 4th, 5th and 6th (top) gear.

CAUTION:

- * *Do not shift gears without disengaging the clutch and closing the throttle. The engine and drive train could be damaged by overspeed and shock.*

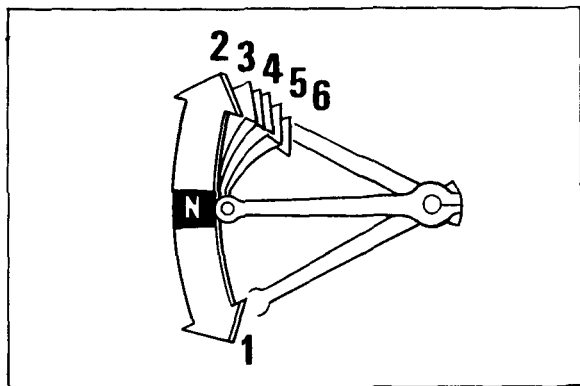

Shifting pattern

Turning Maneuvers

For better traction in off-road use, the ATC has been fitted with a rear axle which drives both rear wheels equally at all times.

When negotiating a turn, the wheel on the outside of the turn must travel a wider radius, and thus a greater distance, than the inside wheel. As the rear axle does not permit a differing rate of wheel rotation, it is not enough to merely steer the ATC into a turn. The new rider must learn to shift his weight and control the throttle to allow the rear tires to negotiate the turn. This is the primary technique to be mastered in riding the Honda ATC.

Practice turning the ATC at slow, constant speeds. Defer higher speeds until you are confident of your proficiency.

Steer in the direction of the turn, and lean your body to the inside of the turn, while supporting your weight on the outer footpeg. Use the throttle to maintain power throughout the turn.

This technique allows the ATC to lean slightly toward the outside, altering the balance of traction between the rear wheels sufficiently to allow them to negotiate the turn.

Once this technique is learned, turning maneuvers can be performed within a relatively small area.

Support your weight
on outer footpeg.

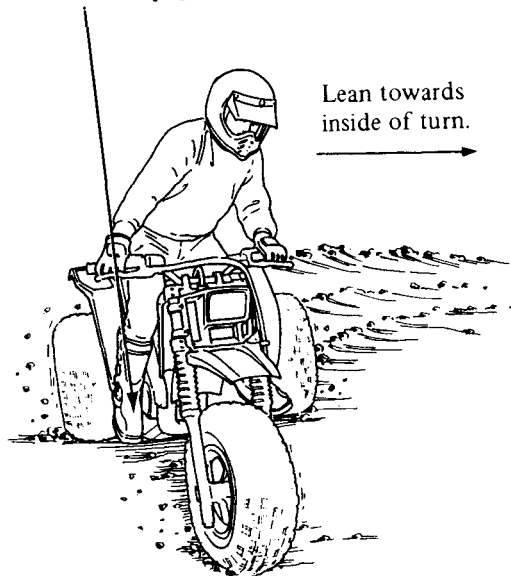

Incorrect turning techniques may cause the front wheel to slide straight ahead when steered without affecting the ATC's direction of travel. If this should occur, close the throttle and come to a stop. Then continue practicing the technique outlined on the preceding page.

If the front wheel tends to skid in mud or snow, you may be able to improve control under these conditions by leaning forward, transferring additional weight to the front wheel.

If the rear wheels inadvertently skid sideways, correct your slide by steering in the direction of the skid if you have room to perform this maneuver safely. Avoid braking or accelerating until you have directional control.

To avoid skids while traveling on slippery terrain, the rider must exercise a high degree of caution. Controlled skids and spins, when performed safely, add to the sport the rider can enjoy. However, as skidding maneuvers are inherently more hazardous than those performed under full traction, we must caution the rider to first master the basic techniques of handling before practicing any skidding maneuver.

Surface composition is, of course, a major factor affecting skidding capability. It is obviously easier to slide on packed snow than in deep sand. Surfaces with extremely low or extremely high coefficients of friction must not be used for skidding maneuvers. It is dangerous to skid on ice, because you may lose all directional control, and it is dangerous to skid on pavement, because you may regain traction suddenly and unexpectedly, which can cause you to lose your balance and overturn.



Climbing Hills

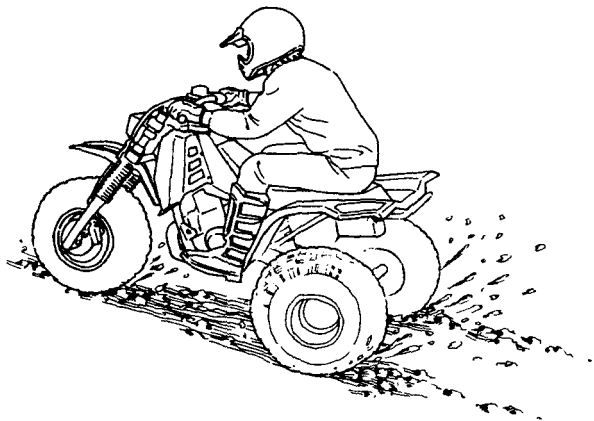

Practice climbing on evenly surfaced slopes of less than 20°. The ATC's capability in climbing hills or traversing any specific terrain is dependent upon rider skill. As you gain experience in handling the ATC, and learn the hazards to be encountered and your own limitations, you may then proceed to ride more challenging terrain. However, you must first be able to discern and avoid any hill or hazard that would cause the ATC to overturn.

The riding technique for hill climbing involves transferring your weight toward the front wheel to keep it in contact with the ground. This may be done by leaning forward, or for greater weight transference, by standing on the footpegs and leaning forward.

Take a running start, in the appropriate gear and speed for the ascent, and climb at a steady rate of speed.

WARNING

- * *Do not apply power suddenly by opening the throttle or changing gears while ascending a hill or the front wheel may rise from the ground. If the front wheel lifts, rider control will be lessened and the ATC may overturn backward.*
- * *Hill should not be crested at high speed. Once over the top of the hill, you may lose control or be thrown from the ATC.*

If you should find that you have incorrectly estimated climbing capability and lack the power or traction to continue the ascent, then if space permits, turn the ATC around while you still have the forward speed to do so and descend. Avoid stalling part way up a hill, as maneuvering will then become more difficult.

WARNING

* *Before attempting a turn on a hillside, the rider should first master turning technique on level ground.*

If you do lose all forward speed, and can neither continue uphill nor maneuver the ATC under its own power, dismount and physically turn the machine around. If it cannot be turned and must be backed down, first shift the transmission into neutral and very carefully back the ATC down, slowing it by use of both brakes. However, we strongly recommend that the rider turn the ATC around rather than back it downhill.

WARNING

* *To avoid overturning, the rider must exercise a high degree of caution when dismounting or lugging the ATC on a hillside.*

* *Applying only the rear brake or engaging the transmission, while rolling backward downhill can easily cause the ATC to overturn and fall on the rider.*



Descending Hills

It is usually advisable to descend hills with the ATC pointed directly downhill, avoiding angles that would cause the vehicle to lean sharply to one side. As you approach the point of descent, stop and survey the terrain below. Never ride headlong past your limit of visibility. When you have picked a safe path of descent, shift the transmission into low gear and descend slowly with the throttle closed. Sit back on the seat, with arms extended and braced on the handlebars.

When descending sand dunes, we recommend that the rider intermittently apply both brakes.

Braking effectiveness is, of course, reduced while descending any incline with a loose surface.

CAUTION:

** Do not lock the brakes or you may lose control.*

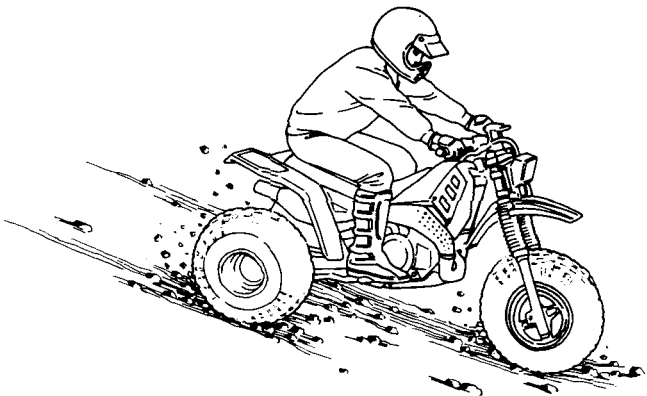

Traversing Slopes

When riding across a slope, at right angles to the incline of the hill, lean your body in the uphill direction to maintain balance and stability. On a loose surface such as sand, it may become necessary to steer slightly uphill in order to maintain your course of travel.

WARNING

- * *Balance is more precarious while the ATC is tilted to one side. Avoid traversing slopes where there is slippery or difficult terrain.*



Riding Through Water

WARNING

- * *Do not ford any stream with fast flowing water. The tires may float, making it difficult to maintain control.*
- * *Do not ride the vehicle through water for extended periods.*

The Honda ATC can ford water to a depth of approximately 300 mm (12 in) although the rider must be careful to avoid getting the spark plug or air cleaner wet from splashing water.

When crossing streams, choose a course where both banks have gradual inclines. Proceed at a slow, steady speed, and take care to avoid submerged obstacles and slippery rocks.

After riding through water, the brakes may be less effective than normal. Test the brakes after traveling through any water, and if necessary, apply the brakes repeatedly until the heat of friction has dried them, and the brakes regain their normal effectiveness.



High Altitude Riding

When operating this vehicle at high altitudes the air-fuel mixture becomes overly rich. Above 5,000 feet (1,500 m) driveability and performance may be reduced and fuel consumption increased. The carburetor can be modified to compensate for this high altitude richness. However, the carburetor must be returned to standard factory specifications when lower altitude riding is desired. (See pages 44–45).

PARKING

1. Stop the vehicle, shift the transmission into low and turn the fuel valve and ignition switch OFF.
2. Apply the parking brake by pulling in the clutch lever and locking it with the lock.

CAUTION:

- * *To start the engine on a slope. Apply the parking brake, shift into neutral and then operate the kick-starter pedal.*

MAINTENANCE

MAINTENANCE SCHEDULE

- The maintenance intervals shown in the following schedule are based upon average riding conditions. Machines subjected to severe use, or ridden in unusually dusty areas, require more frequent servicing. Items marked * should be serviced by an authorized Honda dealer, unless the owner has the proper tools and is mechanically proficient. Other maintenance items are simple to perform and may be serviced by the owner. Perform the Pre-ride Inspection (page 25) at each scheduled maintenance period.
- The U.S. Environmental Protection Agency requires manufacturers to certify that vehicles built after January 1, 1983 will comply with applicable noise emission standards for one year or 3,000 km (1,865 miles) after the time of sale to the ultimate purchaser, when operated and maintained according to the instructions provided. Compliance with the terms of the Distributor's Warranty for the Honda Vehicle Noise Emission Control System is necessary in order to keep the noise emission control system in effect. (USA only)

I: Inspect and Clean, Adjust, Lubricate or Replace, if necessary C: Clean R: Replace A: Adjust L: Lubricate			INITIAL SERVICE PERIOD (First week of operation)	REGULAR SERVICE PERIOD (Every 30 operating days)	Refer to page
	TRANSMISSION OIL	NOTE(1)	R	R	14
	AIR CLEANER ELEMENT	NOTE (2)	C	C	47
	SPARK PLUG			I	38
*	CARBURETOR		I	I	43

I: Inspect and Clean, Adjust, Lubricate or Replace, if necessary C: Clean R: Replace A: Adjust L: Lubricate		INITIAL SERVICE PERIOD (First week of operation)	REGULAR SERVICE PERIOD (Every 30 operating days)	Refer to page
	RADIATOR COOLANT		I, R* (EVERY 2 YEARS)	16
*	RADIATOR CORE	NOTE (3)	I	—
*	COOLING SYSTEM HOSE AND CONNECTIONS		I	—
	FUEL LINE		I: (EVERY YEAR)	42
*	FUEL FILTER		C: (EVERY YEAR)	42
	THROTTLE OPERATION		I	54
	DRIVE CHAIN	NOTE (2), (3)	I, L	54
	CHAIN SLIDER		I	56
*	FRONT FORK OIL		R: (EVERY YEAR)	—
*	SUSPENSION		I	—
	SWINGARM BEARING		I, L	—
	FRONT AND REAR BRAKE FLUID		I	I, R*: (EVERY YEAR) 50
*	FRONT AND REAR BRAKE PAD	NOTE (2), (3)	I: (EVERY YEAR)	52

I: Inspect and Clean, Adjust, Lubricate or Replace, if necessary C: Clean R: Replace A: Adjust L: Lubricate		INITIAL SERVICE PERIOD (First week of operation)	REGULAR SERVICE PERIOD (Every 30 operating days)	Refer to page
	FRONT AND REAR BRAKE SYSTEM	I	I	—
*	CLUTCH	A	A	48
*	SPARK ARRESTER		C	57
	ALL NUTS, BOLTS, FASTENERS	I	I	—
	LIGHTING EQUIPMENT	I	I	—
	TIRES	I	I	18
*	STEERING HEAD BEARING	A: (EVERY YEAR)		—

NOTE: (1) Replace every 30 operating days or every 3 months, whichever comes first.
(2) Service more frequently when riding in dusty areas, sand or snow.
(3) Service more frequently after riding in very wet or muddy conditions.

WARNING

- * *Always turn the engine off before performing any maintenance operations unless otherwise stated.*
- * *To maintain the safety and reliability of your HONDA ATC, do not modify it and use only new genuine HONDA parts or their equivalent when servicing or repairing. The use of replacement parts which are not of equivalent quality may impair the operation of your ATC.*

TOOL KIT

The tool kit is stored in the compartment (1) as shown below. The tools provided are sufficient to perform routine maintenance and simple repairs. Any extensive work requiring additional tools should be performed by an authorized Honda dealer.

- Pin spanner
- 6 mm hex wrench
- 12 mm box wrench
- Pliers
- Screwdriver
- Grip for screwdriver
- 8 x 12 mm open end wrench
- 10 x 14 mm open end wrench
- Tool bag
- 21 mm box wrench

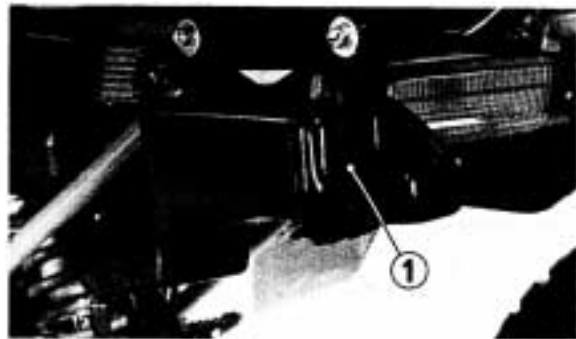

(1) Tool kit compartment

FUEL FILTER

The fuel filter is incorporated in the fuel valve. Accumulation of dirt in the filter will restrict the flow of fuel and therefore, the fuel filter should be serviced periodically.

1. Drain the fuel from the fuel tank. Disconnect the fuel line.

WARNING

** Gasoline is extremely flammable and is explosive under certain conditions. Perform this operation in a well ventilated area. Do not smoke or allow flames or sparks in the area.*

2. Remove the fuel valve (1) by loosening the mounting bolt and remove the fuel filter (3). Wash it in clean non-flammable or high flash point solvent.

WARNING

** Never use gasoline or low flash point solvents for cleaning the fuel filter. A fire or explosion could result.*

3. Make sure the O-ring (2) is in place. Reinstall the fuel filter and fuel valve in the reverse order of removal and turn the fuel valve ON. Check for leaks.
4. Check the fuel line for deterioration, damage or leakage. Replace if necessary.

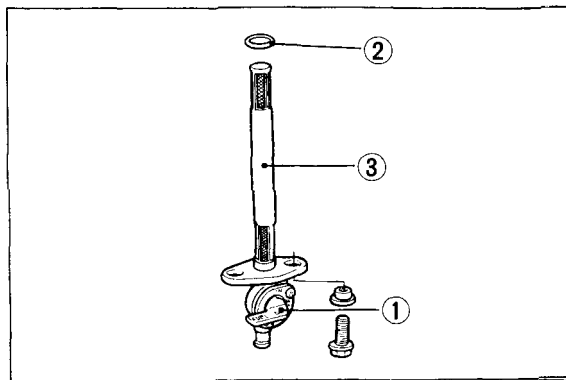

(1) Fuel valve

(3) Fuel filter

(2) O-ring

CARBURETOR

NOTE:

- * Do not attempt to compensate for faults in other systems by carburetor adjustment. See your authorized Honda dealer for regularly scheduled carburetor adjustments.
- * The engine must be warm for accurate idle adjustment. Ten minutes of riding is sufficient.

1. Warm up the engine.
2. Adjust idle speed with the throttle stop screw (1).
IDLE SPEED $1,400 \pm 150$ rpm
3. Turn the air screw (2) clockwise until you hear the engine miss or decrease in speed, then counter-clockwise until the engine again misses or decreases in speed. Center the air screw exactly between these two extreme positions.

Usually the correct setting (between extremes of rich and lean) will be found to be 2 turns open from a fully closed position.

If idle speed changes after adjusting fuel mixture, readjust the throttle stop screw.

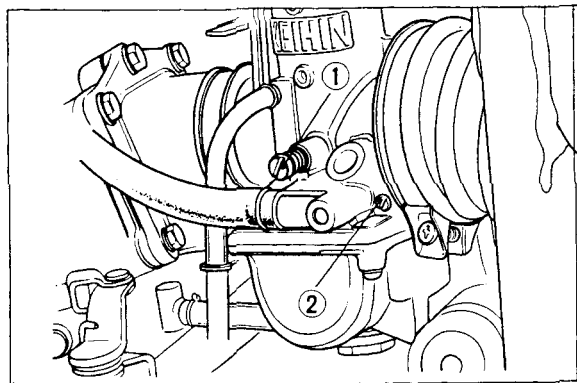

(1) Throttle stop screw (2) Air screw

Carburetor adjustment (Altitude and Temperature)

Although installation and adjustment procedures are offered here, unless you are mechanically proficient and have the necessary tools, we strongly urge that the carburetor modifications, installation and adjustment procedures given here be performed by your authorized Honda dealer.

NOTE:

* Four optional main jets are enclosed in the tool compartment.

* For the following recommendations to be accurate. You must use the standard settings as a base line. Also, don't change any of the settings until you've determined what changes are necessary.

Standard settings:

Main jet	Jet needle setting	Air screw openings
# 142	2nd groove	2 turns out

1. Find your factor on the chart.

		Temperature			
		-25°C - -17.5°C (-22°F - 0°F)	-17.5°C - -5°C (0°F - 22°F)	-5°C - 40°C (22°F - 104°F)	
Altitude	5000 feet - (1500m -)	Main jet	# 142	# 140	# 138
		Jet needle setting	3rd groove	2nd groove	1st groove
		Air screw opening	2 turns out	2-1/2 turns out	2-1/2 turns out
	3300-6600 feet (1000-2000m)	Main jet	# 145	# 142	# 140
		Jet needle setting	4th groove	3rd groove	2nd groove
		Air screw opening	1-1/2 turns out	2 turns out	2 turns out
	0-5000 feet (0-1500m)	Main jet	# 148	# 145	# 142
		Jet needle setting	4th groove	3rd groove	2nd groove
		Air screw opening	1-1/2 turns out	2 turns out	2 turns out

2. Turn the fuel valve OFF.
3. Turn the carburetor drain bolt counterclockwise and drain the carburetor.

WARNING

* *Gasoline is extremely flammable and is explosive under certain conditions. Perform this operation in a well ventilated area. Do not smoke or allow flames or spark in the area.*

4. Remove the fuel line.
5. Remove the screws securing the carburetor bands
6. Remove the carburetor top when changing the jet needle clip position.
7. Remove the carburetor and remove the float bowl plug

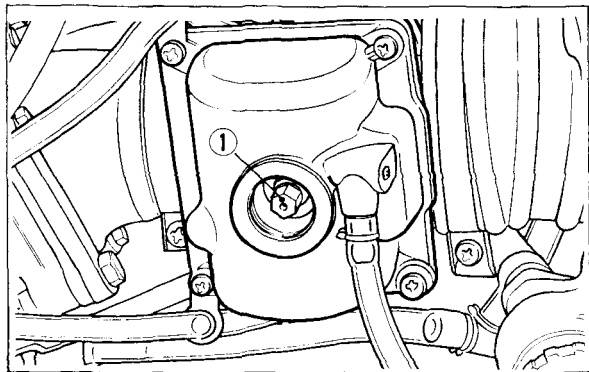

(1) Main jet

8. Change the main jet (1) and the jet needle clip position as required.
9. Install the carburetor top and install the carburetor.
10. Install the fuel line and tighten the carburetor drain bolt and carburetor band screws.
11. Adjust the air screw opening as required.
12. Check for any fuel leaks.

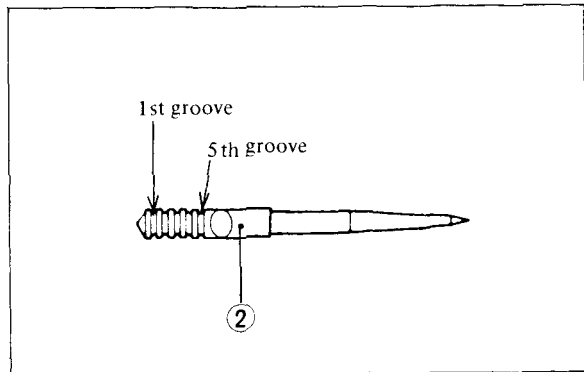

(2) Jet needle

SPARK PLUG

CHAMPION RN2C
NGK BR9ES

CAUTION:

* *The use of spark plugs of incorrect size or heat range can cause serious engine damage.*

1. Clean any dirt from around the spark plug base.
2. Disconnect the spark plug cap and remove the plug with the wrench provided in the tool kit.
3. Visually inspect the spark plug electrodes for wear. The center electrode should have square edges and the side electrode should not be eroded. If the electrodes and insulator tip appear unusually fouled or burned, we suggest that you contact an authorized Honda dealer to determine the cause of this condition. Discard the spark plug if there is apparent wear or if the insulator is cracked or chipped.
4. Make sure that the spark plug gap is 0.7–0.8 mm (0.028–0.031 in) using a feeler gauge. If adjustment is necessary, bend the side electrode (1) carefully.

5. With the plug washer attached, thread the spark plug in by hand to prevent **cross-threading**.
6. Tighten a new spark plug $\frac{1}{2}$ turn with a spark plug wrench to compress the washer. If you are reusing a plug, it should only take $\frac{1}{8}$ – $\frac{1}{4}$ turn after the plug seats.

CAUTION:

* *The spark plug must be securely tightened. An improperly tightened plug can become very hot and possibly damage the engine.*

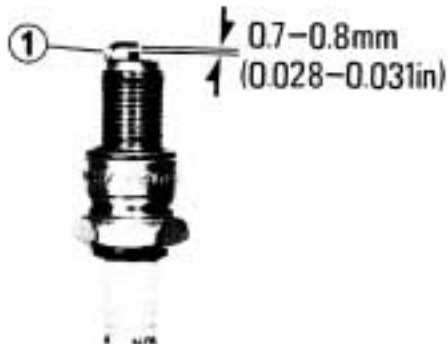

(1) Side electrode

AIR CLEANER

The air cleaner element accumulates dust and must be cleaned periodically. If the ATC250R is ridden in unusually dusty areas, the element must be cleaned at more frequent intervals than specified in the MAINTENANCE SCHEDULE.

1. Remove the seat by sliding the lever.
2. Remove the clips (1) and remove the air cleaner cover (2).
3. Remove the air cleaner by removing screws (3).
4. Remove the filter element (4) and wash it in non-flammable or high flash point solvent. Allow it to dry thoroughly.

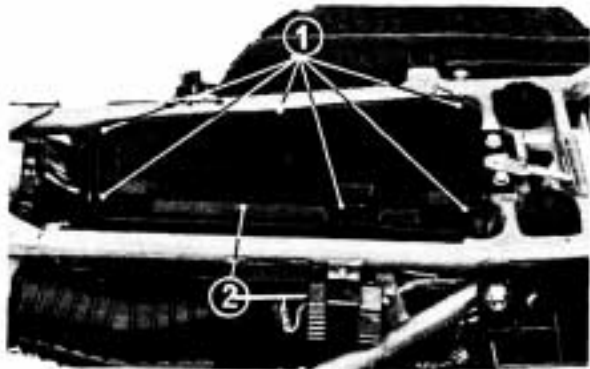

- (1) Clips
(2) Air cleaner cover

5. Soak the filter element in clean gear oil (SAE 80–SAE 90) until saturated, then squeeze out the excess oil.
6. Reassemble by reversing the disassembly sequence.

WARNING

- * *Never use gasoline or low flash point solvents for cleaning the air cleaner element. A fire or explosion could result.*

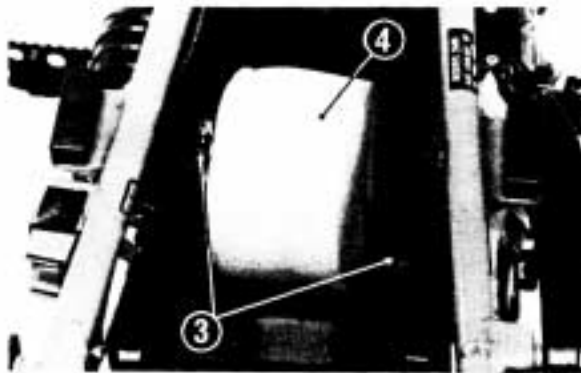

- (3) Screws
(4) Filter element

CLUTCH

Clutch adjustment may be required if the ATC stalls when shifting into gear, or tends to creep; or if the clutch slips, causing acceleration to lag behind engine speed.

Normal clutch lever free play is 10–20 mm (3/8–3/4 in) at the lever (1).

Minor adjustments can be made with the clutch cable adjuster (2) at the lever (1).

1. Loosen the lock nut (3) and turn the clutch cable adjuster (2). Tighten the lock nut (3) and check adjustment.

2. If the adjuster is threaded out near its limit or the correct free play cannot be obtained using the cable adjuster (2), loosen the lock nut (3) and turn in (B) the adjuster (2) completely. Tighten the lock nut (3).

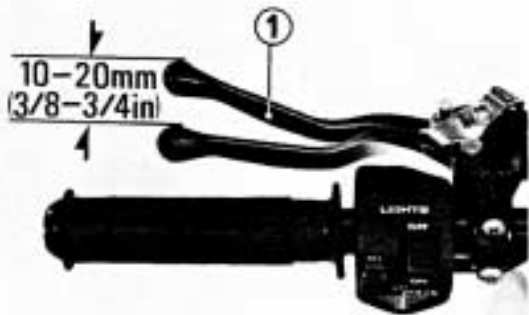

(1) Clutch lever

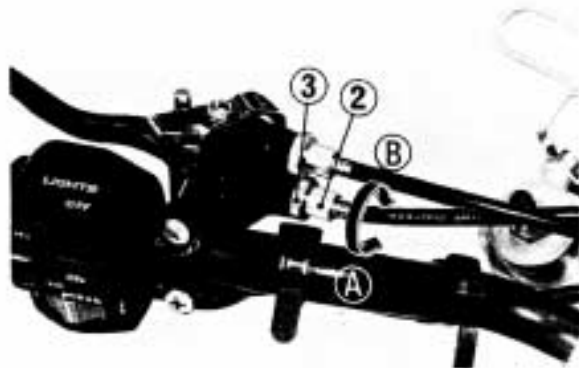

(2) Clutch cable

(3) Lock nut

(A) Decrease free play

(B) Increase free play

3. At the lower end of the cable, loosen the lock nut (5). Turn the adjusting nut (4) to obtain the specified free play. Tighten the lock nut (5), and check adjustment.
4. Start the engine, pull in the clutch lever and shift into gear. Make sure the engine does not stall, and the ATC does not creep. Gradually release the clutch lever and open the throttle. The ATC should start smoothly and accelerate gradually.

NOTE:

- * If proper adjustment cannot be obtained or the clutch does not work correctly, the cable or clutch friction discs may be worn. Refer to the official Honda shop manual or see your authorized Honda dealer.

Other Checks:

Check the clutch cable for kinks or signs of wear that could cause sticking or failure. Lubricate the clutch cable with a commercially available cable lubricant to prevent premature wear and corrosion.

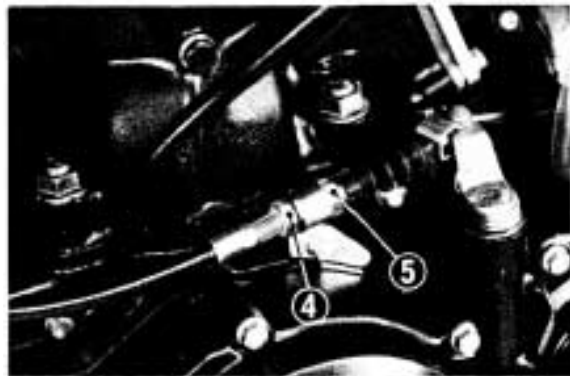

- (4) Adjusting nut
- (5) Lock nut

BRAKES

Both front and rear brakes are hydraulic disc types. As the brake pads wear, brake fluid level drops, automatically compensating for wear.

There are no adjustments to perform, but fluid level and pad wear must be inspected periodically. The system must be inspected frequently to ensure there are no fluid leaks.

NOTE:

- * If the brake lever or pedal travel become excessive and the friction pads are not worn beyond the recommended limit (page 52), there is probably air in the brake system and it must be bled. See your authorized Honda dealer.

WARNING

- * *Brake fluid may cause irritation. Avoid contact with skin or eyes. In case of contact, flush thoroughly with water and call a doctor if your eyes were exposed.*

Front Brake Fluid Level:

Remove the screws, reservoir cap and diaphragm. Whenever the level is near the lower level mark (1), fill the reservoir with DOT 3 or 4 BRAKE FLUID from a sealed container, up to the upper level mark. Reinstall the diaphragm and reservoir cap. Tighten the screws securely.

CAUTION:

- * *When adding brake fluid be sure the reservoir is horizontal before the cap is removed or brake fluid may spill out.*



(FRONT) (1) Lower level mark

CAUTION:

- * Use only DOT 3 or 4 brake fluid from a sealed container.
- * Handle brake fluid with care because it can damage paint.
- * Never allow contaminants (dirt, water, etc.) to enter the brake fluid reservoir.

Rear Brake Fluid Level:

Remove the reservoir cap and diaphragm. Whenever the level is near the lower level mark (4) on the rear reservoir, fill the reservoir with DOT 3 or 4 BRAKE FLUID from a sealed container, up to the upper level mark (3). Reinstall the diaphragm, and tighten the reservoir cap securely.

CAUTION:

- * Use only DOT 3 or 4 brake fluid from a sealed container.
- * Handle brake fluid with care because it can damage paint.
- * Never allow contaminants (dirt, water, etc.) to enter the brake fluid reservoir.

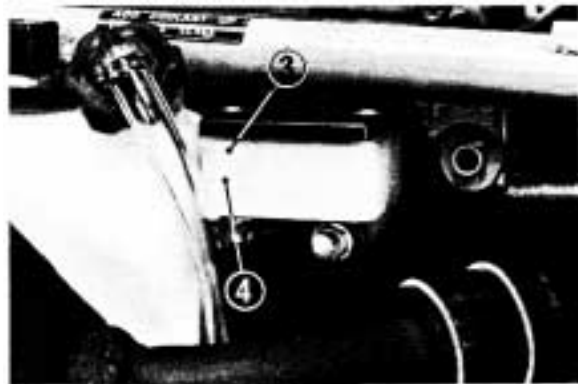

(REAR) (3) Upper level mark
(4) Lower level mark

Brake Pads:

Brake pad wear will depend upon the severity of usage and riding conditions. The pads will wear faster in wet or muddy conditions. Inspect the pads visually during all regular service intervals to determine the pad wear. If either pad wears to the marking (1), both pads must be replaced.

CAUTION:

* *The front and rear brake pads are not interchangeable. When replacing brake pads be sure to install correct brake pads.*

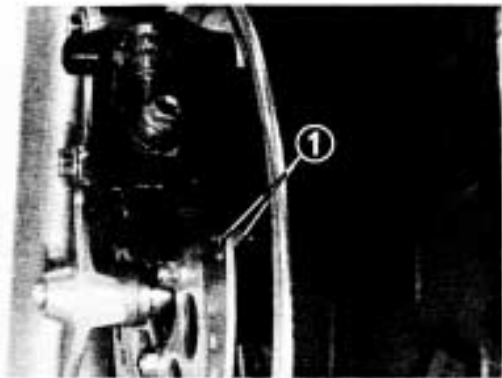

(1) Marking

Other Checks:

Make sure there are no fluid leaks. Check for deterioration or cracks in the hose and fittings.

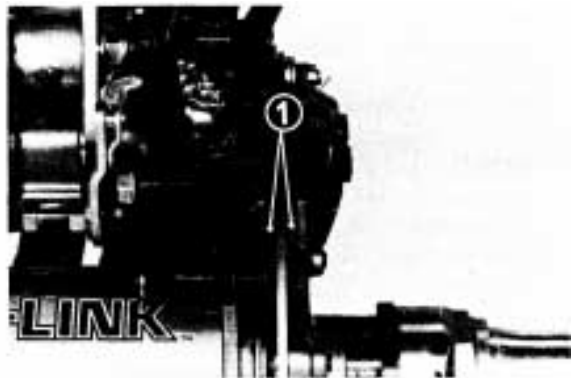

(1) Marking

Parking brake

Parking brake adjustment may be required if the parking brake does not hold properly.

Adjustment

1. Loosen the lock nut (1) on the rear caliper.
2. Screw the adjusting bolt (2) until you feel resistance without applying the clutch/parking brake lever, and tighten the lock nut (1).

3. Measure the distance the parking brake arm (3). The arm free play should be 3.5–4.5 mm (0.14–0.18 in) at the tip of the parking brake arm.
4. Adjust the distance 31–39 mm (1.2–1.5 in) measured at the tip of clutch/parking brake lever by loosening the lock nut (4) and turn the adjuster (5), while pushing the parking brake pin (6).
5. Recheck the distance of the parking brake arm.

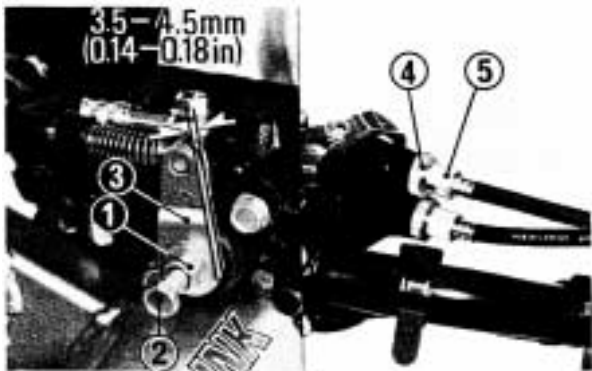

- (1) Lock nut
- (2) Adjusting bolt
- (3) Parking brake arm

- (4) Lock nut
- (5) Adjusting nut

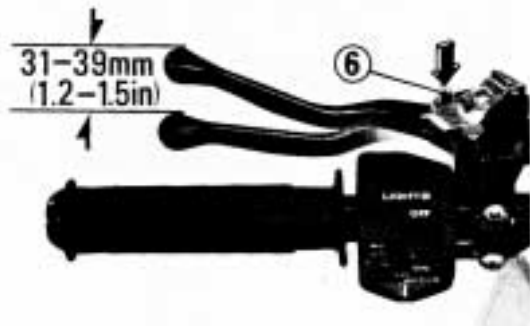

- (6) Parking brake pin

THROTTLE CABLE

Inspect throttle cable condition and operation. The cable must not bind or impair smooth operation of the throttle lever in any steering position. Replace the cable if it has become worn or kinked. Lubricate the cable with a commercially available cable lubricant to prevent premature wear and corrosion.

Free play, measured from the forward edge of the throttle lever (1) should be maintained at 3–8 mm (0.12–0.31 in). The cable adjuster (3) is located near the throttle lever. Loosen the lock nut (2) and turn the adjuster to obtain the correct free play.

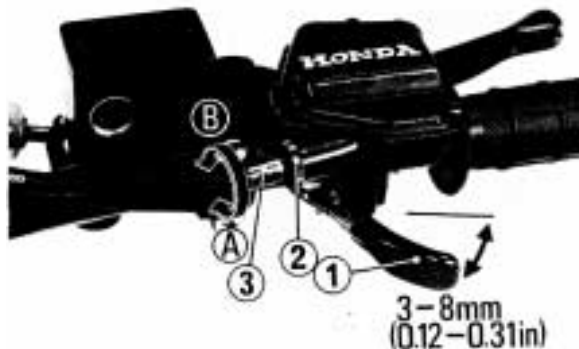

- | | |
|--------------------|------------------------|
| (1) Throttle lever | (A) Decrease free play |
| (2) Lock nut | (B) Increase free play |
| (3) Cable adjuster | |

DRIVE CHAIN

The drive chain (1) will wear with use and requires periodic adjustment in accordance with the maintenance schedule.

NOTE:

* Check, adjust or lubricate the chain with the engine off.

Chain slack should be checked by measuring the amount of chain slack midway between the sprockets. The amount of slack should be 30–40 mm (1.2–1.6 in).

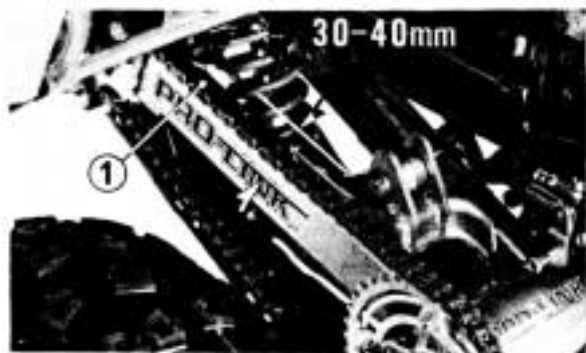

(1) Drive chain

To adjust slack, loosen two lock bolts (2). Turn the adjuster (4) to decrease or increase chain slack using the tool provided (3). After adjusting the chain slack 30–40 mm (1.2–1.6 in), retighten the lock bolts.

NOTE:

* If drive chain slack is excessive when the adjuster is moved to the limit of adjustment, the drive chain is worn and must be replaced. See your authorized Honda dealer to replace.

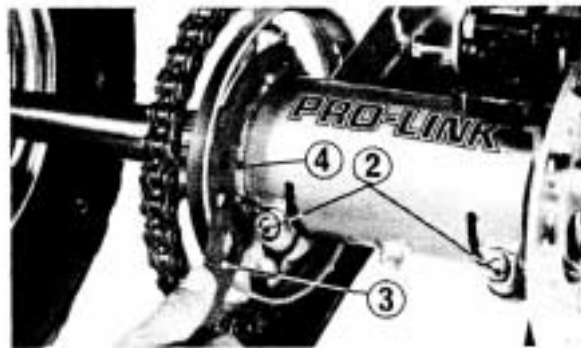

(2) Lock bolts
(3) Provided tool

(4) Adjuster

Lubrication and cleaning:

Lubricate every 30 days of riding or sooner if chain appears dry. The O-rings in this chain can be damaged by steam cleaning, high pressure washers, and certain solvents.

Clean the chain with kerosene. Wipe dry and lubricate only with SAE 80 or 90 gear oil. Commercial chain lubricants may contain solvents which could damage the rubber O-rings.

Drive Chain Slider

Check the drive chain slider at the designated interval. Replace the slider if the depth of the groove exceeds 2.0 mm (0.08 in).

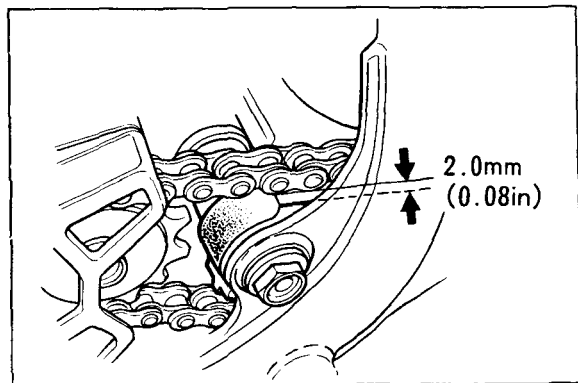

(1) Chain slider

SPARK ARRESTER

The exhaust system must be periodically purged of accumulated carbon.

WARNING

- * *The exhaust system becomes VERY HOT even after short periods of engine operation.*
- * *To avoid fire hazards, DO NOT perform this maintenance in the vicinity of flammable materials.*

1. Remove the bolts (1) and muffler plate (2).
2. Start the engine, and purge accumulated carbon from the system by momentarily revving up the engine several times.
3. Stop the engine and allow the exhaust pipe to cool.
4. Reinstall the muffler plate and bolts.

CAUTION:

- * *The two mounting screws (3) must be installed in the spark arrester body at all times for the spark arrester to be effective.*

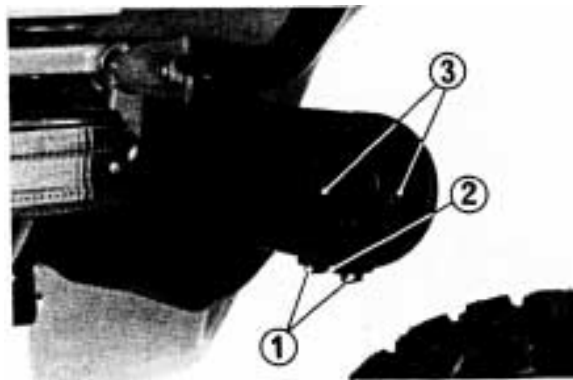

(1) Bolts
(2) Muffler plate

(3) Bolts

STORAGE

Storage:

1. Completely clean all parts of the ATC. If the ATC has been exposed to sea air or salt water, wash it down with fresh water and wipe dry.
2. Make sure the cooling system is filled with a 50/50% antifreeze solution.
3. Drain the fuel tank and carburetors. Spray the inside of the tank with an aerosol rust-inhibiting oil. Reinstall the fuel cap on the tank.
Turn the fuel valve to RES and remove the carburetor drain bolt; drain gasoline into an approved container. Reinstall the drain bolt.

WARNING

- * *Gasoline is flammable and is explosive under certain conditions. Do not smoke or allow flames or sparks near the equipment while draining fuel.*
4. Inflate the tires to their normal pressure and place the ATC on blocks to raise the tires off the ground.
 5. Cover the ATC and store in a place which is free of humidity and dust.

Removal from Storage

1. Uncover and clean the ATC. Change the transmission oil if more than 4 months have passed since the start of storage.
2. Drain any excess aerosol rust-inhibiting oil from the fuel tank. Fill the fuel tank with fresh gasoline-oil mixture.
3. Perform all Pre-ride Inspection checks (page 25). area away from traffic.

TRANSPORTING

1. Turn the fuel valve OFF.
2. Remove the drain bolt to drain the fuel from the carburetor.
3. Reinstall the drain bolt.

WARNING

- * *Never transport the machine on its side or with the front wheel straight up unless all fuel has been drained.*

NOTE:

- * Be sure the drain bolt is tightened.
- * If wheel removal is required when transporting, follow the procedures on the following pages.

Front Wheel Removal

1. Place a support block under the engine to raise the front wheel off the ground.
2. Remove the four wheel hub nuts (1).
3. Remove the two bolts (2) securing the front brake caliper (3).
4. Loosen the axle holder nuts (4) and remove the axle (5).
5. Remove the axle collar (6) and front wheel.

Installation

1. Install the axle holder with UP mark (7) facing upwards. Install the holder nuts (4). Do not tighten them at this time.

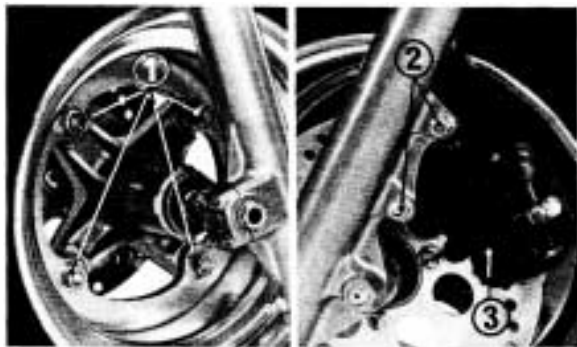

(1) Wheel hub nuts

(2) Bolts

(3) Front brake caliper

2. Install the front wheel and collar (6) and insert the front axle (5).
3. Tighten the axle to 70–110 N·m (7.0–11.0 kg·m, 51–80 ft-lb) torque.
4. Tighten the axle holder nuts (4) to 10–14 N·m (1.0–1.4 kg·m, 7.2–10.1 ft-lb) torque.
5. Install the front brake caliper (3) with the hose guide and tighten it to 20–30 N·m (2.0–3.0 kg·m, 14.5–21.7 ft-lb) torque. Install the wheel hub nuts (1) and tighten them to 60–70 N·m (6.0–7.0 kg·m, 45–50 ft-lb) torque.

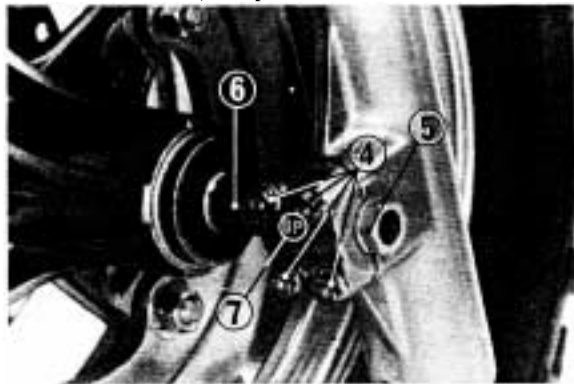

(4) Axle holder nuts

(5) Axle

(6) Axle collar

(7) UP mark

CAUTION:

- * *When the front axle is reinstalled, be careful that the grease seal is not cut or damaged.*

 **WARNING**

- * *Be certain that the holding nuts and axle are tightened. If they are not, the wheel may come loose during operation.*
- * *If a torque wrench was not used for installation, see your authorized Honda dealer as soon as possible to verify proper assembly.*

Rear Wheel Removal

1. Place a support block under the vehicle and raise the rear wheel off the ground.
2. Loosen the wheel nuts (1).
3. Remove the wheel.

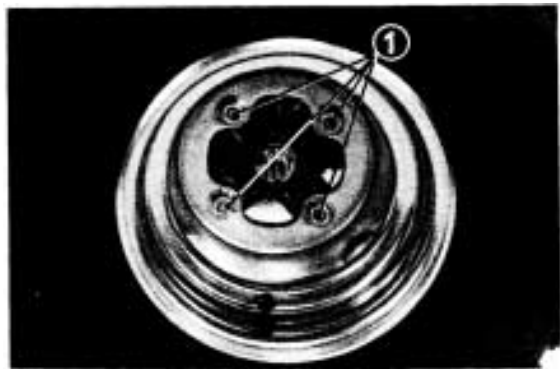

(1) Wheel nuts

Installation:

Reinstall the rear wheel and tighten the wheel nuts (1) in a cross-pattern, torquing them to 60–70 N·m (6.0–7.0 kg·m, 45–50 ft·lb).

⚠ WARNING

** If a torque wrench was not used for installation, see your authorized Honda dealer as soon as possible to verify proper assembly.*

NOISE EMISSION CONTROL SYSTEM(USA ONLY)

TAMPERING WITH THE NOISE CONTROL SYSTEM IS PROHIBITED: Federal law prohibits the following acts or the causing thereof: (1) The removal or rendering inoperative by any person, other than for purposes of maintenance, repair, or replacement, of any device or element of design incorporated into any new vehicle for the purpose of noise control prior to its sale or delivery to the ultimate purchaser or while it is in use: or (2) the use of the vehicle after such device or element of design has been removed or rendered inoperative by any person.

AMONG THOSE ACTS PRESUMED TO CONSTITUTE TAMPERING ARE THE ACTS LISTED BELOW:

1. Removal of, or puncturing the muffler, baffles, header pipes or any other component which conducts exhaust gases.
2. Removal of, or puncturing of any part of the intake system.
3. Lack of proper maintenance.
4. Replacing any moving parts of the vehicle, or parts of the exhaust or intake system, with parts other than those specified by the manufacturer.

SPECIFICATIONS

DIMENSIONS	
Overall length	1,895 mm (74.6 in)
Overall width	1,120 mm (44.1 in)
Overall height	1,090 mm (42.9 in)
Wheelbase	1,295 mm (51.0 in)
WEIGHT	
Dry weight	132 kg (291 lb)
CAPACITIES	
Transmission oil	0.7 liter (0.74 US qt, 0.62 Imp. qt) after disassembly
Fuel tank	9.8 liter (2.6 US gal, 2.2 Imp. gal)
Fuel reserve capacity	2.0 liter (0.52 US gal, 0.43 Imp. gal)
Passenger capacity	Operator only
ENGINE	
Bore and stroke	66 x 72 mm (2.6 x 2.8 in)
Compression ratio	8.0

ENGINE	
Displacement	246 cc (15 cu.in)
Spark plug gap	0.7–0.8 mm (0.028–0.031 in)
CHASSIS AND SUSPENSION	
Caster angle	21°
Trail length	37 mm (1.5 in)
Tire size	front 23 x 8–11 rear 20 x 10–9
POWER TRANSMISSION	
Primary reduction	2.652
Final reduction	3.000
Gear ratio, 1st	2.570
2nd	2.062
3rd	1.667
4th	1.333
5th	1.083
6th	0.884

WIRING DIAGRAM

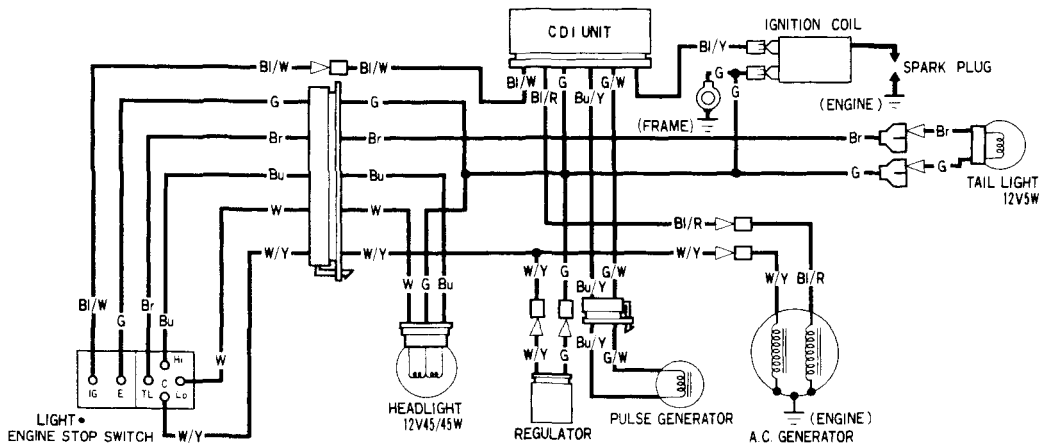

- | | | | | | |
|----|-------|--------|----|-------|-------------|
| BI | | BLACK | Br | | BROWN |
| Y | | YELLOW | O | | ORANGE |
| Bu | | BLUE | Lb | | LIGHT BLUE |
| G | | GREEN | Lg | | LIGHT GREEN |
| R | | RED | P | | PINK |
| W | | WHITE | Gr | | GRAY |

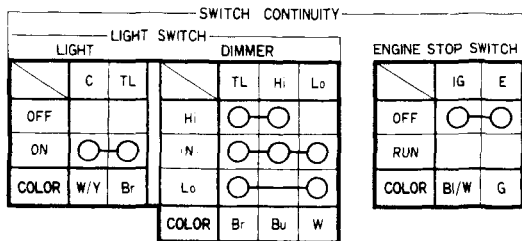

0030Z—HA2—0000

//////////////////// PERIODIC REPLACEMENT PARTS //////////////////////

Machines subject to severe use, or ridden in unusually dusty areas, require more frequent servicing. The following table serves as a guide in replacing parts when machines are intended for competitions.

Part Name	Interval	Items to be checked
Piston	Every 30 Hour	Damage at skirt, wear
Piston pin	Every 30 Hour	Seizure, damage, wear
Piston rings	Every 30 Hour	Chipped end, wear
Connecting rod small and bearing	Every 30 Hour	Wear, damage
Spark plug	Every 20 Hour	Worn electrode, improper gap, cracked insulator
Transmission oil	Every 30 Hour	Fouling, emulsion
Drive sprocket	Every 20 Hour	Wear, damage
Chain slider	Every 30 Hour	Amount of recess: 2.0 mm max
Drive chain	-----	
Chain master link	Every 30 Hour	Wear
Front brake pads	-----	Wear indicator
Rear brake pads	-----	Wear indicator
Front brake fluid	Every years	Fouling, emulsion
Rear brake fluid	Every years	Fouling, emulsion
Master cylinder oil cap diagram	Every 2 years	Damage
Front brake hose	Every 4 years	Cracks, damage
Rear brake hose	Every 4 years	Cracks, damage
Fuel hose	Every 4 years	Cracks, leaks, damage
Cylinder head gasket	Every 30 Hour	Leak
Clutch disc	-----	Discoloration, wear
Exhaust chamber spring	-----	Wear on hook

OPTIONAL PARTS

Speedometer



Front over fender

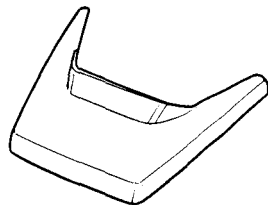

Headlight lens grille

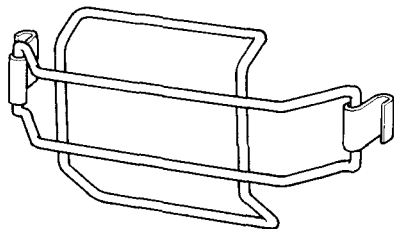

Headlight guard

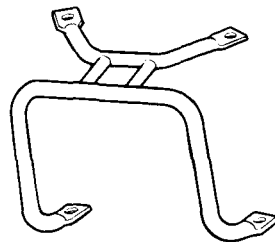

Fender stabilizer

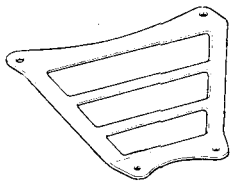

Rubber step



Body cover

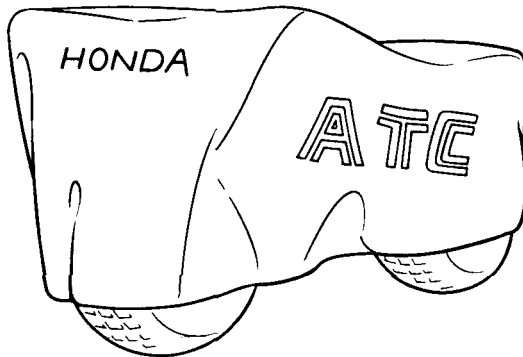

Warranty Service

Owner Satisfaction

Your satisfaction and goodwill are important to your dealer and to us. All Honda warranty details are explained in the Distributor's Limited Warranty. Normally, any problems with the product will be handled by your dealer's service department. Sometimes, however, in spite of the best intentions of all concerned, misunderstandings can occur. If your problem has not been handled to your satisfaction, we suggest you take the following action:

- Discuss your problem with a member of dealership management. Often complaints can be quickly resolved at that level. If the problem has already been reviewed with the Service Manager, contact the owner of the dealership or the General Manager.
- If your problem still has not been resolved to your satisfaction, contact the Customer Relations Department at the regional office of American Honda Motor Co., Inc. in your area. Regional office locations are shown on the following page. We will need the following information in order to assist you:
 - Your name, address, and telephone number
 - Product model and serial number
 - Date of purchase
 - Dealer name and address
 - Nature of the problem

After reviewing all the facts involved, you will be advised of what action can be taken. Please bear in mind that your problem will likely be resolved at the dealership, using the dealer's facilities, equipment, and personnel, so it is very important that your initial contact be with the dealer:

Your purchase of a Honda product is greatly appreciated by both the dealer and American Honda Motor Co., Inc. We want to assist you in every way possible to assure your complete satisfaction with your purchase.

31HA2600
PRINTED IN USA