

SERVICE MANUAL

L-99 (IF-100-1)
L-230 (IF-250-1), L-227
L-295 (IF-295-1), R-295 (IF-295-2)
L-297, L-300
L-340 (IF-340-1), R-340 (IF-340-2)

LR-340/2 (2F-340-1)
LR-399/2 (2F-400-1)
LR-440/2 (2F-440-2)
LB-600/2 (2F-600-1)

Index

Engine fundamentals, operating instructions.....	12
Carburetors, Spark Plugs.....	4
Ignition Systems (Flywheel Magneto, Starter).....	5
Exhaust Systems.....	5
Disassembly/Assembly, Engine and Recoil; Timing Instructions:	
Single Cylinder	
L-99 (IF-100-1).....	10
L-230 (IF-250-1), L-227.....	10
L-295 (IF-295-1), R-295 (IF-295-2)	
L-297, L-300.....	22
L-340 (IF-340-2)	
Twin Cylinder	
LR-340/2 (2F-340-1)	
LR-399/2 (2F-400-1).....	29
LR-440/2 (2F-440-2)	
LB-600/2 (2F-600-1)	
Wiring Diagrams.....	37
Trouble Shooting	
General.....	43/47
Ignition.....	47
Starter.....	48
Carburetor	
HR,HD.....	49/51
WR,WD.....	52
Service Items, Gasket Sets, Spark Plug Recommendations.....	53/54
Conversion Factors, Tables, Reference Data.....	55/59
General Specifications.....	60/61
Dimensional Data.....	62/64
Warranty.....	64

2-Cycle Engine Fundamentals

The 2-cycle, air-cooled gasoline engine has become very popular today for snowmobiles, ATV's and other recreational vehicles. It is uniquely qualified for these applications because of its relatively high power output, light weight, and ease of lubrication, with fewer moving parts than conventional 4-cycle engines.

However, in order to get the best possible use, and assure that it retains its high degree of dependability and endurance, it must receive proper care and maintenance. Since the life expectancy of any 2-cycle gasoline engine depends to a great degree on the level of maintenance it receives, it is necessary for us to know something about the basic fundamentals of an engine and how it functions in order to determine and apply, the correct amount of maintenance.

Operation

The JLO 2-cycle engine is of the loop-scavenged, 3rd-port design type . . . the most widely used design today. It uses a mixture of gasoline and oil for combustion, lubrication and cooling. It fires on every second stroke of the piston. However, each down stroke of the piston is a power stroke, that is, a power stroke for every revolution of the crankshaft.

As the piston moves upward in the cylinder (Illustration A), it draws the fuel/air mixture into the lower crankcase while

at the same time compressing the fuel already in the compression chamber above. As the piston completes its upward stroke, the spark plug ignites the compressed fuel and the burning fuel expands and forces the piston downward on its second, or power stroke (Illustration B). In this downward stroke the piston not only turns the crankshaft but compresses a new charge of fuel in the crankcase while continuing downward clearing the exhaust ports (Illustration C) in the cylinder wall to release the burned gasses through the ports and out into the exhaust system. The piston continues downward to uncover the transfer port and release the compressed fuel charge into the cylinder where it displaces the remaining burned gasses and forces them out through the exhaust ports (Illustration D).

Because lubrication of 2-cycle engines depends on mixing predetermined amounts of oil and fuel, it is extremely important that good quality oil be thoroughly mixed with fuel and in proper proportions. While there are different engines, as well as different oils, requiring different fuel mixtures, the correct oil-fuel ratio required for Rockwell-JLO engines is 20 to 1. Use of little oil may cause engine over-heating, piston or cylinder scoring and eventual engine seizure or failure. Too much oil, on the other hand, leads to incomplete combustion, carbon fouling of plugs and piston overload. Refer to page 5 for recommended oil-fuel mixture ratios.

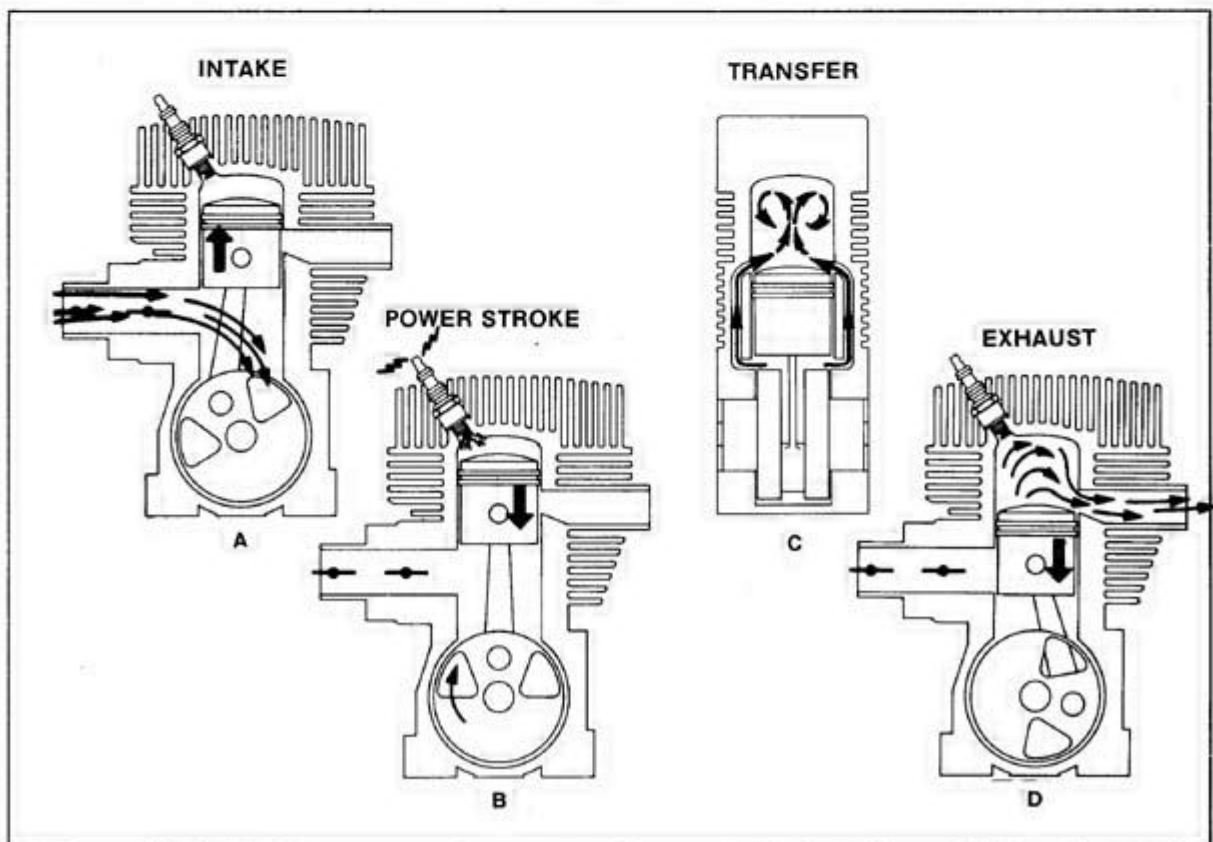

Operating Instructions

Break-in, Starting/Stopping, Fuel Mixture

Break-In

During the first few hours do not operate the engine at full throttle. Run for short periods of time at varying speeds up to 3/4 throttle. Use 16:1 mixture ratio on first tank of fuel; 2 gallons of fuel to 16 ounces of oil.

Starting Procedure

1. Turn switch to "on" position.
2. Close choke (warm engine requires little or no choking).
3. Open throttle slightly when cranking the engine.
4. As soon as the engine starts open choke and release throttle.
5. Electric start: Turn switch to "start" position. Release as soon as the engine starts (switch will remain in "on" position). Do not continue cranking the engine if it fails to start after approximately 30 seconds. Allow the starter to cool before making another attempt. If the battery is low use the recoil starter.

Operation

Before operating at full load, let engine warm up at moderate speed (1/2 to 3/4 throttle) for a few minutes. Avoid prolonged idling to prevent carbon build-up from fouling spark plugs or cause carburetor flooding. Engines put under severe strain, as in racing, may continue running after the ignition is turned off. To stop the engine under these conditions, shut off the air supply by closing the choke.

Stopping Procedure

Release the throttle to allow engine to idle. Turn switch to "off" position.

Do not use the choke to stop the engine. This can result in carburetor flooding, making it very difficult to restart.

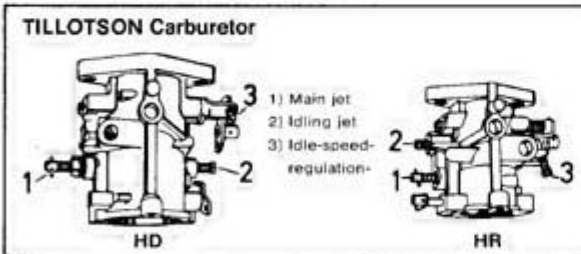

Carburetor Adjustment:

Adjust carburetor prior to putting engine into service or if operating conditions have changed.

Before starting the engine close both jets and reopen as indicated below. Open main jet (1) 1 1/8 turn, open idle jet (2) 1 1/2 turn.

- a) Run vehicle under full load and at the same time slowly close the main jet (1) until engine runs smooth. Continue to close main jet until engine turns maximum rpm. For correct adjustment open main jet at least 1/8 of a turn to prevent engine from operating too lean.
- b) Adjust idling jet (2) for smooth idling and transmission to load ranges. The actual idling speed however is adjusted by the idling speed-regulation screw (3).

- c) When operating the engine at higher altitudes, a somewhat leaner setting may be required; close jets a little by turning clockwise. At extremely low temperatures a somewhat richer adjustment may become necessary; open jets a little by turning counterclockwise.

Never run engine when adjusted too lean; it may result in severe damage.

Safety Precautions

1. Never add fuel while the engine is running as spilled fuel might ignite on contact with hot engine surfaces. Stop engine and allow to cool.
2. Always be sure ignition switch is in "off" position before working on engine.
3. Make sure all safety shields or guards on engine and driven equipment are in proper position and securely fastened.
4. When starting, keep hands, feet and clothing at a safe distance from moving parts.
5. Do not operate the engine in closed buildings unless exhaust pipe is vented to the exterior.
6. Fuel may escape from fuel tank vent when operating over rough terrain, on an incline, or from expansion, and can ignite from hot engine surfaces or an electrical spark. Stop engine and remove some fuel from the tank.

Fuel Mixture

Gas/Oil Ratio	Ounces Of Oil	Gasoline Required
20 to 1	32	5 Gallons
20 to 1	26	4 Gallons
20 to 1	19	3 Gallons
20 to 1	13	2 Gallons
20 to 1	6.5	1 Gallon

NOTE: Mix gasoline (high test preferable), with SAE 30-40 air-cooled engine oil. Premix thoroughly before pouring into vehicle tank by first mixing 1 gallon of gasoline with all the oil, shaking vigorously and then adding the rest of the gasoline. Always use fresh, clean gasoline to avoid gumming up or clogging the carburetor.

Carburetors

Diaphragm Type Carburetors

In order to atomize the oil-fuel mixture and mix it with proper proportions of air flowing to the intake port or intake manifold, it is necessary to utilize a carburetor. Carburetor design is based on the venturi principle whereby a gas or liquid flowing through a restricted or necked-down passage increases in velocity and decreases in pressure as compared to the velocity and pressure in the full size section of the passage.

There are various types of carburetors classified by method of delivery of fuel to the carburetor: float, suction lift and diaphragm type. JLO Engines mainly use diaphragm type carburetors, therefore, future references herein will be limited to this type of carburetor.

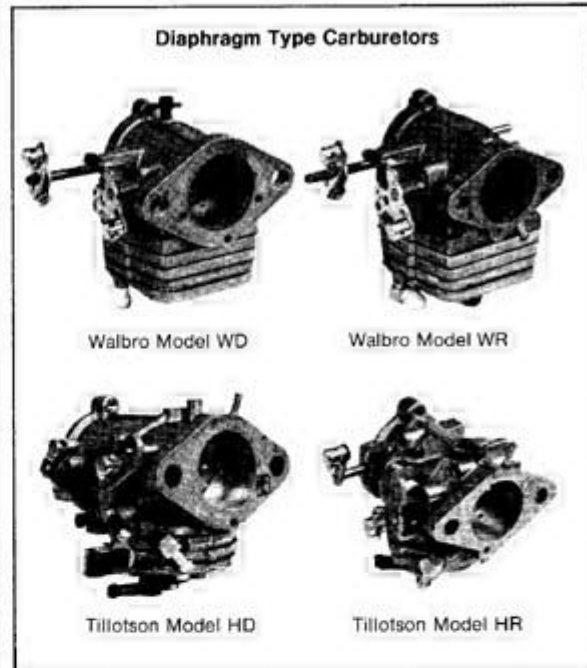

Basic Operation

Fuel from the supply tank is drawn in the fuel inlet (1) into the surge chamber (2) through the filter screen (3) by pulsations of the fuel pump diaphragm (4). The engine crankcase pulsations transmitted through the external impulse fitting (9) or internal impulse hole (9A) actuates the fuel pump diaphragm (4) which supplies pumping action for the fuel pump. The fuel is drawn from the surge chamber through the check valve (5) and the channel (6). The fuel continues past the fuel pump outlet check valve (7) and into channel (8). Fuel continues through fuel channel (8) and to the needle valve (28). The metering lever spring (29) transmits a force through the metering lever (30) and seats the inlet needle valve (28) against pressure. The metering diaphragm (10) is pulled upward by engine suction which is transmitted through the idle discharge port (14) secondary idle holes (16) and part throttle holes (17). The diaphragm action depresses the metering lever (30) and unseats the needle valve (28) and allows the fuel to enter the metering diaphragm chamber (31) and pass through the idle take off (11). Check valve (32) is forced open passing fuel into the main nozzle (21) which also feeds the part throttle holes (17). Fuel only is fed through a discharge holes.

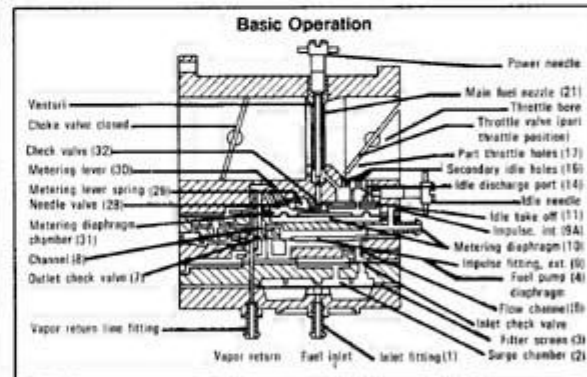

Courtesy of Walbro Corp.

Spark Plugs

Selection of Spark Plugs

The use of the correct spark plug is vitally important in getting the most out of your engine. The spark plug recommended is balanced to the magneto or the ignition system and also designed to burn the fuel thoroughly in the engine.

If a spark plug has a colder heat range than recommended, carbon deposits will accumulate on the insulating surface in the bore. These deposits will cause the spark plug to misfire or "short out." A spark plug with a hotter heat range causes rapid erosion of the electrode and could cause a breakdown of the ignition system or can cause preignition and piston seizure. Many spark plugs are thrown away long before they should be. The plug is not always the answer to why the engine stopped. When an engine stops do not just replace the plug, but instead check the complete ignition system and *be sure you are using the correct spark plug.*

One simple way to test the ignition system is to remove the high tension lead wire from the tip of the spark plug and hold it approximately 3/16 in. away. Pulling on the starter cord should produce enough voltage to cause a spark to jump from the high tension lead wire to the tip of the spark plug. If this occurs, the ignition system is functioning and the problem is elsewhere.

What should you do if there is a spark and the engine won't start? Remove the spark plug from the engine and inspect its condition. The electrode should be free of any carbon deposits and the electrode should not be burned. At this stage check the gap of the plug. The carbon around the insulator should be light tan which signifies a complete burning of the fuel.

Oily black carbon signifies a deficiency in the ignition system. If you are using the correct spark plug in the correct heat range and these carbon deposits show, an inspection of the points should also be made. If you find the points burned, replace them.

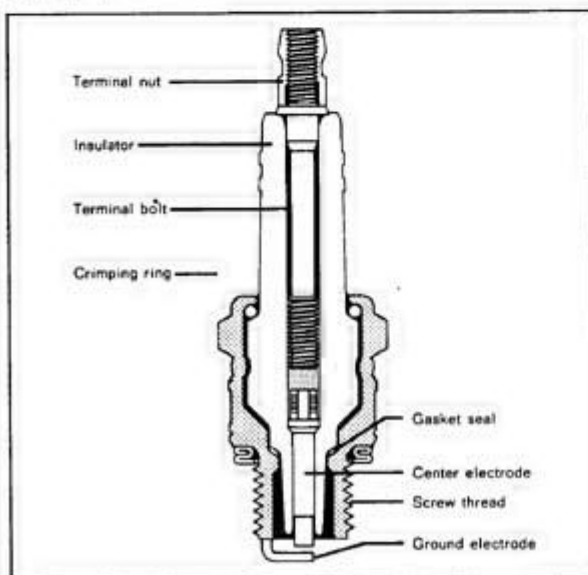

Courtesy of Robert Bosch, GMBH.

NOTE: The carburetor adjustment has a direct effect on spark plug selection.

If, for instance, an overheated appearance of the electrode cannot be rectified by going to a richer carburetor adjustment, a colder plug should be selected. If, on the other hand a fouled plug does not show improvement by leaner adjustment, select a hotter plug.

Using the standard spark plug supplied with the engine as a base, racing or high speed driving usually requires colder plugs, while low speed driving normally calls for a hotter plug. Keep the spark plug gap to specification.

Typical Spark Plug Conditions

Normal Condition

Plug has run at correct temperature; deposits are light tan color. Electrode is not burnt. Plug can be cleaned, gapped and reused with good results. Compare this plug with those illustrated below.

Sooted

Mixture too rich, not enough air, spark gap too large, heat value too high.

Oiled

Too much oil in mixture; worn cylinders and piston rings.

Overheated

Mixture too lean, spark plug not gas-tight or not properly screwed in, or thermal value of spark plug too low results in spark plug becoming too hot.

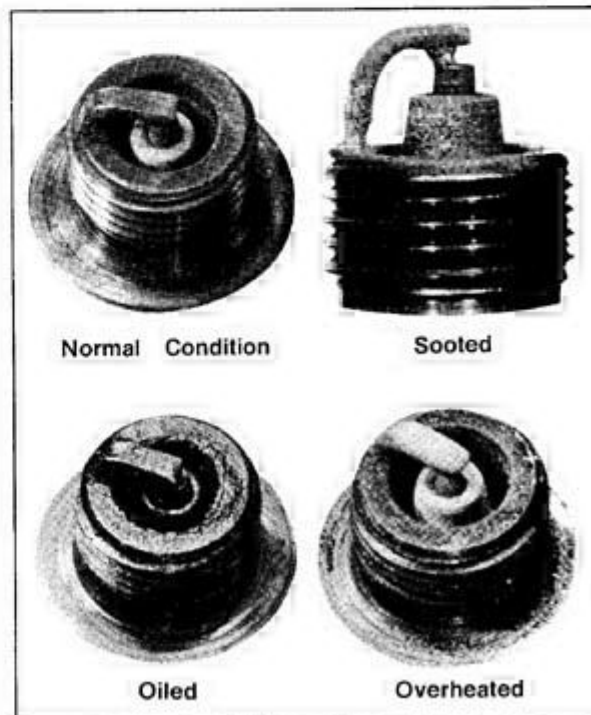

Ignition System

Magneto and Starters

Flywheel Magneto

A flywheel type magneto along with a high tension wire and spark plug supplies energy to ignite the fuel-air mixture in the cylinder. Energy for ignition is induced in the ignition windings on stator by permanent magnets in the magnet ring mounted on the flywheel. The magnet ring also includes the automatic spark advance mechanism. As engine speed increases, centrifugal force moves the timing advance lever outward and shifts the ignition cam thereby causing the breaker points to open earlier. Rotation of the permanent magnets causes current to flow in the primary winding. When ignition is required, the breaker points are opened by the action of the breaker cam rod. This causes a halt in current flow in the primary winding and results in a sudden collapse of the magnetic field surrounding the coil windings. At this instant, the rapid change in the concentration of magnetism causes a voltage to be induced in every turn of both the primary and secondary windings. In the primary winding the energy, which may be as high as 250 volts, is quickly absorbed by the condenser. The condenser thus acts as a reservoir for the surge of energy in the primary coil winding. If this energy had nowhere to go, it would arc across the points and cause a complete breakdown of the entire function. The condenser holds this energy only for an instant after which time it is released back into the primary. The voltage built up in the secondary, which has up to 100 times as many turns as the primary, could go as high as 25,000 volts. Normally, however, voltage does not increase to this value. It increases only to the amount sufficient to bridge the spark gap. This is usually between 6,000 and 20,000 volts. The actual value depends upon such variables as compression, speed, shape and condition of electrodes, width of spark gap, etc.

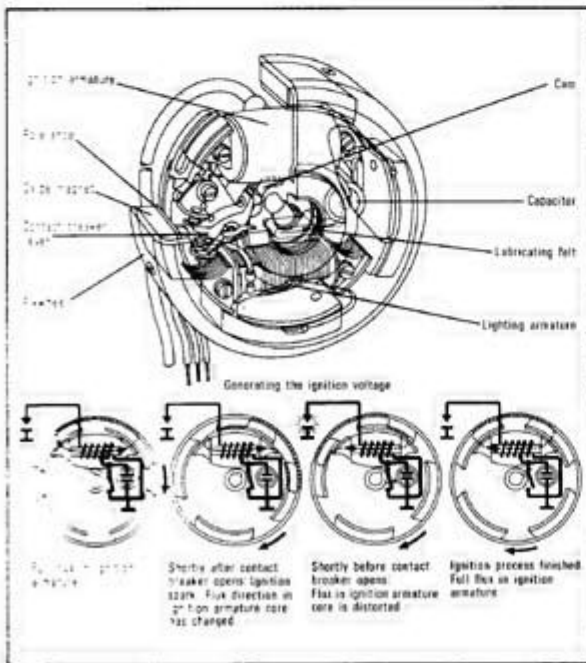

Courtesy of Robert Bosch, GMBH.

Electric Starters

Most starters used on JLO engines are of the Bendix type and seldom need servicing. The oil impregnated, self-lubricating bushings require no attention. The brushes and commutator should be occasionally checked for wear or dirt. Problems which might arise from time to time are covered in the "Trouble Shooting the Starter" page 27.

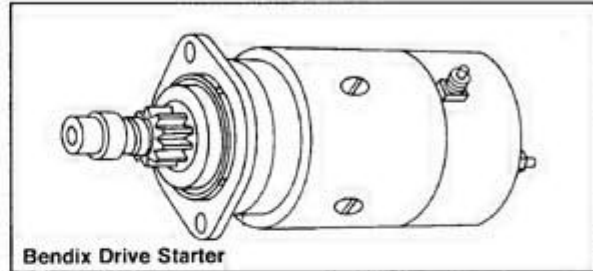

Bendix Drive Starter

Brushes

The starter does not have to be removed from engine to service brushes. To gain access to the brushes on these starters, remove the bushing protective cap, the clip washer at end of the armature, then the commutator end (C.E.) cap or plate. Note that it may be necessary to loosen the lower nut on the terminal post so that the plastic terminal insulator will not crimp and hold the end cap. Tap end cap lightly to free it from the starter frame, then slip it off over the end of the commutator and armature. Use a small hook to lift springs then remove each brush from its holder for inspection and cleaning. If brushes are worn unevenly or worn down to less than 5/16" (about half original length) unsolder leads and replace all 4 brushes.

Clean commutator with coarse, lint free cloth—do not use emery cloth or sandpaper for this. If it is grooved, scored or extremely dirty, the commutator should be turned down on a lathe.

When reinstalling brush holder, leave brushes out and springs off until after the brush ring is over the commutator. Insert brushes then hook springs and position on brushes—CAUTION: Brushes can be damaged if the springs are allowed to "snap" against the top of the brushes. Align thru bolts and pull the end cap down tight then install clip (after making sure end play washers are in place). Reinstall and secure the bushing cap to complete brush service.

Bendix Drive

The starter must be removed from the engine to inspect Bendix drive assembly except in the case of Models LR-340/2, LR-399/2 and LR-440/2. If the splined shaft or pinion are dirty, clean with solvent which does not leave a film—the drive works best with only small amount of lubricant—use the dry spray type.

If it is damaged, replace the complete Bendix drive assembly. To remove, drive the ring stop back toward the pinion, then remove snap ring. Spring, bushing and pinion assembly can now be removed. Reverse this procedure to reinstall new Bendix.

Ignition System

Flywheel Alternator, Ignition Timing

Flywheel Alternator

Except for the model L-99, all JLO engines are equipped with an electrical system that provides energy for head and tail lights and current to charge the battery. The source of this energy is an independent coil which is attached to the stator plate. Depending on the type of coil it can produce 40 or 75 watts. If the engine is not equipped with an electric starter, the lights can be connected to AC current direct. On electric start models both yellow leads must be connected to a rectifier in order to convert the AC current as produced by the coil to DC current for charging the battery.

On either system use a lamp load equal to the total output to prevent lights from burning out. On a 40 watt system use any combination totalling 40 watts. A manual 75 watt engine may need a load resistor to compensate for the extra current. When the lamp load, for instance, is 50 watt, use a 25 watt resistor; when it is 40 watt, use a 35 watt resistor. The resistor should be connected parallel to the lamps.

40 watt systems connected to batteries can do one of two things; charge the battery during daytime driving, or supply lights at night. If on a 75 watt system 60 watts are used for lights, the remaining current can still charge the battery. However do not exceed a lamp load of 60 watts.

The rectifier contains two fuses which blow whenever a short occurs in the wiring harness or when the polarity of the battery is changed. This prevents costly repairs. Make it a practice to check these fuses whenever you suspect a failure in your electrical system.

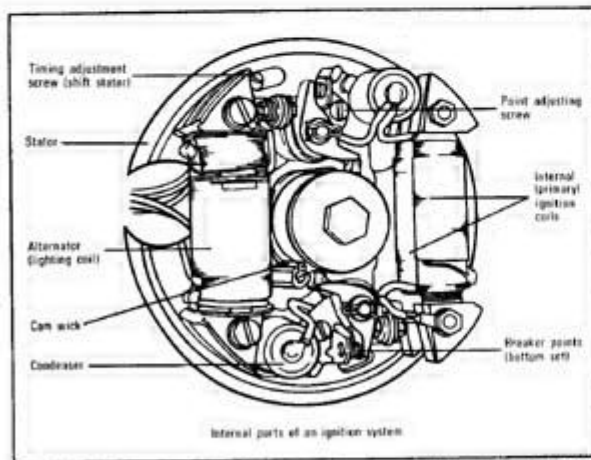

Courtesy of Robert Bosch, GMBH.

Ignition Timing

Ignition timing on 2-cycle engines is very important. It determines the time element necessary to expand the flame front in the combustion chamber. Pre-ignition occurs if the timing is too far advanced (early); loss of power and detonation may result if the timing is retarded (late).

Most high performance engines are equipped with an automatic advance mechanism. It consists of centrifugal weight connected to a freely rotating cam. The purpose of the automatic advance mechanism is to start the engine with its piston as close to top dead center as possible and thus prevent "kick-back". At starting, the spring attached to the lever holds the weight in the retard position. However, as soon as the rpm increases, the centrifugal forces shift the mechanism into the fully advanced position, in turn rotating the cam. The cam opens and closes the contact breaker points. Whenever an engine is equipped with this mechanism the ignition timing must be performed with the centrifugal weight locked in the fully advanced position.

Note: For detailed timing instructions, refer to Disassembly and Assembly Section covering the specific engine model.

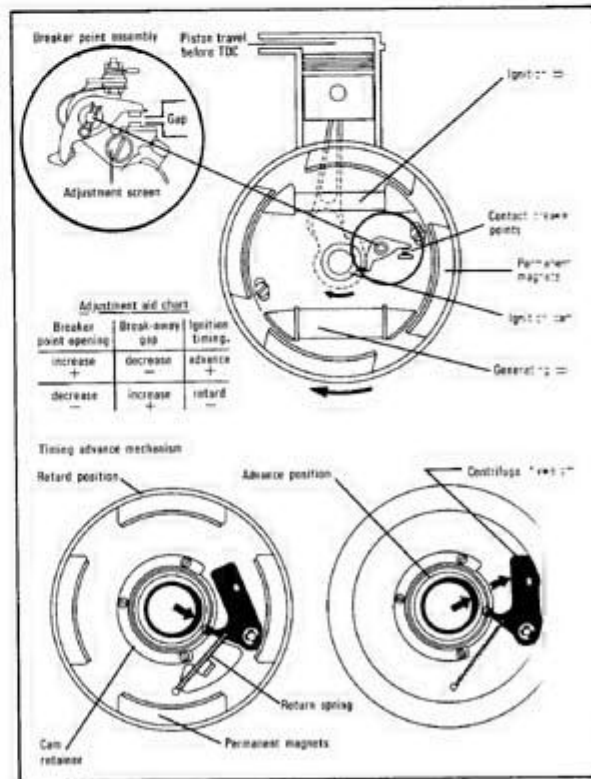

Ignition System

Flywheel Alternator, Ignition Timing

Flywheel Alternator

Except for the model L-99, all JLO engines are equipped with an electrical system that provides energy for head and tail lights and current to charge the battery. The source of this energy is an independent coil which is attached to the stator plate. Depending on the type of coil it can produce 40 or 75 watts. If the engine is not equipped with an electric starter, the lights can be connected to AC current direct. On electric start models both yellow leads must be connected to a rectifier in order to convert the AC current as produced by the coil to DC current for charging the battery.

On either system use a lamp load equal to the total output to prevent lights from burning out. On a 40 watt system use any combination totalling 40 watts. A manual 75 watt engine may need a load resistor to compensate for the extra current. When the lamp load, for instance, is 50 watt, use a 25 watt resistor; when it is 40 watt, use a 35 watt resistor. The resistor should be connected parallel to the lamps.

40 watt systems connected to batteries can do one of two things; charge the battery during daytime driving, or supply lights at night. If on a 75 watt system 60 watts are used for lights, the remaining current can still charge the battery. However do not exceed a lamp load of 60 watts.

The rectifier contains two fuses which blow whenever a short occurs in the wiring harness or when the polarity of the battery is changed. This prevents costly repairs. Make it a practice to check these fuses whenever you suspect a failure in your electrical system.

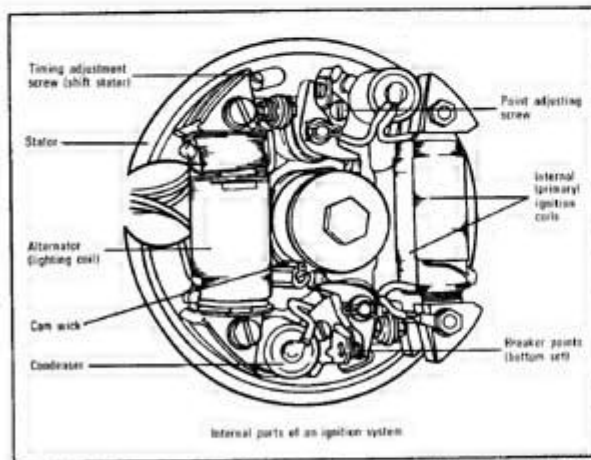

Courtesy of Robert Bosch, GMBH.

Ignition Timing

Ignition timing on 2-cycle engines is very important. It determines the time element necessary to expand the flame front in the combustion chamber. Pre-ignition occurs if the timing is too far advanced (early); loss of power and detonation may result if the timing is retarded (late).

Most high performance engines are equipped with an automatic advance mechanism. It consists of centrifugal weight connected to a freely rotating cam. The purpose of the automatic advance mechanism is to start the engine with its piston as close to top dead center as possible and thus prevent "kick-back". At starting, the spring attached to the lever holds the weight in the retard position. However, as soon as the rpm increases, the centrifugal forces shift the mechanism into the fully advanced position, in turn rotating the cam. The cam opens and closes the contact breaker points. Whenever an engine is equipped with this mechanism the ignition timing must be performed with the centrifugal weight locked in the fully advanced position.

Note: For detailed timing instructions, refer to Disassembly and Assembly Section covering the specific engine model.

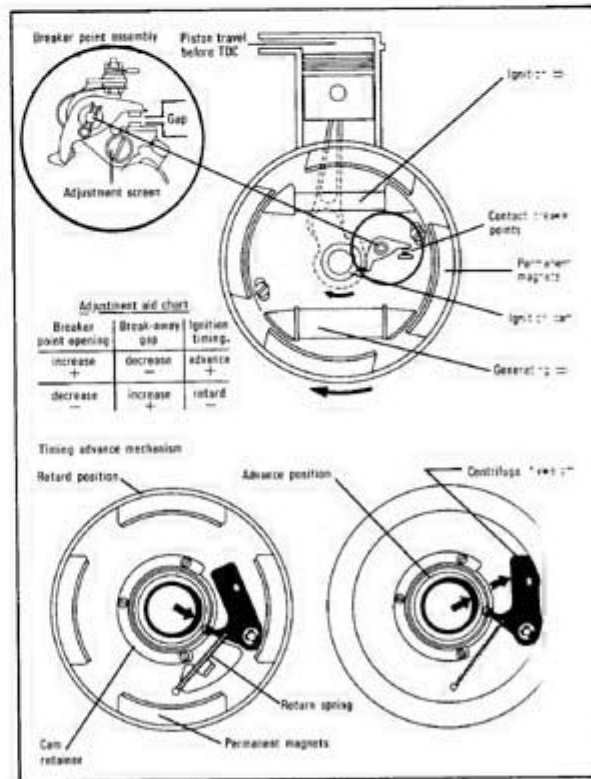



JLO Single Cylinder Engines

Disassembly and Assembly Procedure - Model L-99 (IF-100-1)

Disassembly

A. Fan Cover and Recoil Starter

Remove the five slotted screws holding fan cover to the crankcase. (Fan cover and recoil starter housing are integral unit.) For detailed service instructions, refer to Recoil Starter, Disassembly and Assembly.

B. Carrier Drum

With 17 mm. socket remove hex nut recessed in carrier assembly. Remove carrier drum from flywheel.

C. Spark Plug

Remove spark plug with socket wrench.

D. Flywheel

Remove flywheel with special flywheel puller. Turn threaded puller bolt until it touches tip of crankshaft. Continue turning bolt clockwise to extract the flywheel. Remove Woodruff key.

E. Ignition Coil

With 10 mm. wrench remove the two bolts holding coil to crankcase body. Disconnect wires from condenser and contact breaker.

F. Contact Breaker; Ignition Cam

Fixed Cam Models: remove slotted screw holding breaker points to crankcase; lift out points and backing plate.

Independent Cam Models: remove slotted screw holding points to crankcase; lift out Woodruff key, cam, spring washers and backing plate.

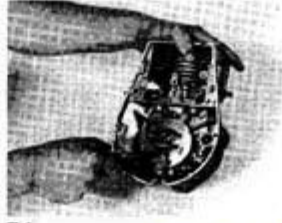
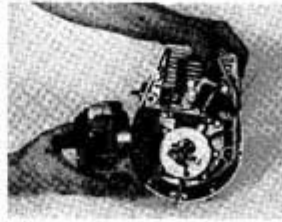
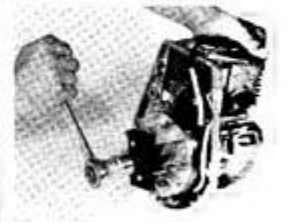
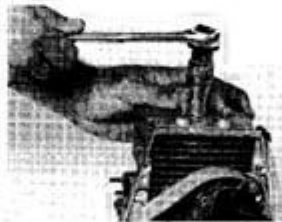
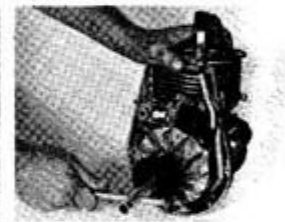
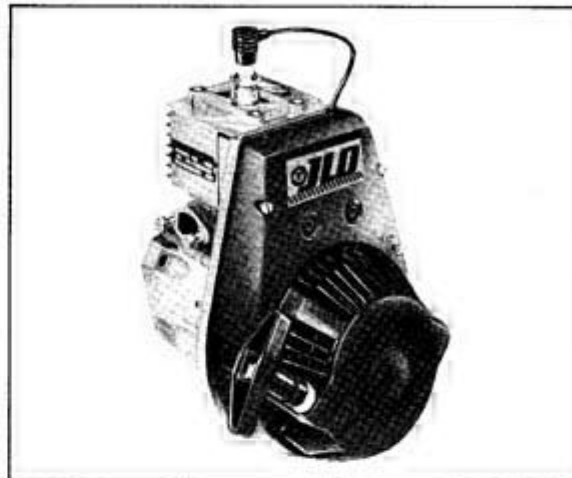

F1

F2

G. Cylinder

Remove four cylinder base nuts with 10 mm. wrench. Gently lift up cylinder until it clears the skirt. (Cylinder head and cylinder are integral.) Remove cylinder base gasket.

H. Piston

With needle nose pliers remove the wrist pin circlips—one on each side of pin. Gently drive out the wrist pin and lift off the piston. Remove connecting rod bearings.

I. Crankcase

To separate the crankcase: 1) remove six screws on the crankcase housing; 2) turn crankcase on its side (ignition side facing up); 3) slide hollow protective pipe over oil seal (pipe should have I.D. slightly larger than oil seal); 4) using protective gloves, apply heat around bearing seat (do not overheat); 5) lift off, separating casting; 6) turn crankcase so F.O. end is up and proceed as per points 3, 4 and 5. Important: do not cut oil seal on sharp edges of crankshaft keys. Should crankcase separate without application of heat, it is an indication that both crankcase castings are worn out and should be replaced.

J. Crankshaft

Place crankshaft on work surface and use special puller to remove bearings: 1) slide puller over crankshaft and align bolt with crankshaft end; 2) slip half shells around the bearing and engage them with puller grooves; 3) slide retaining ring over half shells to keep them on bearing; 4) use 2 wrenches and turn puller bolt with one wrench while holding puller body with the other; 5) keep turning bolt clockwise until bearing comes to the end of crankshaft.

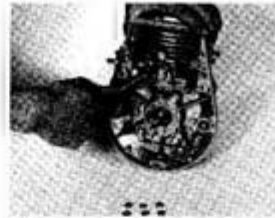

G1

G2

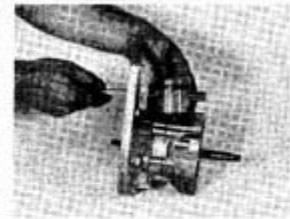
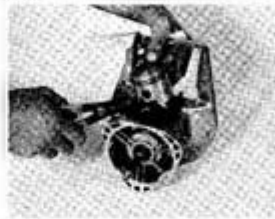

H1

H2

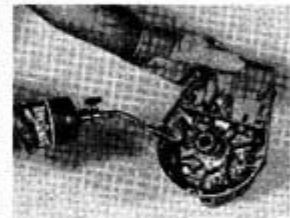
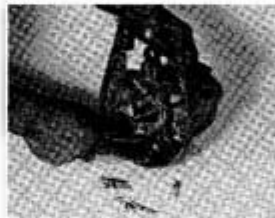

I1

I2

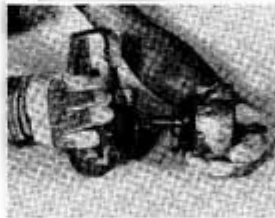

I3

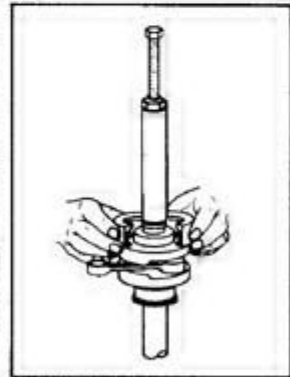

J1

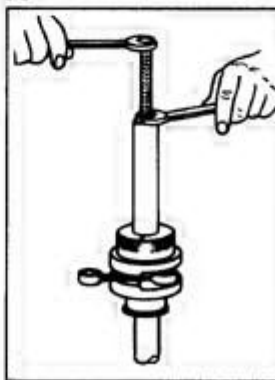

J2



JLO Single Cylinder Engines

Disassembly and Assembly Procedure - Model L-99 (IF-100-1)

Assembly

1. Crankshaft

Heat crankshaft bearings in oil preheated to 215°F. After reaching temperature, quickly slip bearing over end of crankshaft; it should fall freely on the counterweight. Using a hollow pipe with a diameter approximately that of the inner bearing race, hit pipe with a rubber hammer and seat the bearing on the shaft. The bearing should now rest securely and turn freely. Repeat procedure for bearing on other end of crankshaft.

2. Crankcase

Check both halves of crankcase and clean, carefully removing any left-over gasket material or burrs; 2) with the ignition side of the crankcase facing up, heat bearing seat area while protecting oil seal with a hollow pipe; 3) guide crankshaft through the oil seal until the bearing fits easily into its seat; 4) let casting cool, then install crankcase gasket; 5) to install the other half of the crankcase, repeat items 2, 3 and 4, as applicable; 6) insert the 6 Allen Head screws and tighten slightly; 7) check alignment of crankcase halves with a straight edge and 8) firmly tighten Allen Head screws, crosswise.

3. Piston and Cylinder

Clean carbon deposits from the piston. Check to see that rings move freely in their grooves. Install piston with the arrow pointing toward the exhaust port. Gently guide the piston over the connecting rod and insert the wrist pin. Snap circlips into each side of the piston using needle-nose pliers. Install cylinder-base gasket. Place a V-shaped wood block under the piston, resting it on the crankcase. After lining up the rings with the locating pins on the piston, compress them with a ring compressor. Rest piston on wood block and carefully slide cylinder over the piston until the rings disappear into the cylinder. Remove ring compressor and wood block. Install four cylinder base nuts and torque-down crosswise. (6/7 ft. lbs.).

4. Contact Breaker

A. Fixed cam models:

Insert backing plate into crankcase housing and attach breaker points using lockwasher and slotted screw.

B. Independent cam models:

Install backing plate. Slide spring washers over crankshaft, insert Woodruff key and slide cam into position. Install breaker points using slotted screw and washer.

5. Ignition Coil

Attach ignition coil to crankcase with two 6 mm. bolts (use 10 mm. wrench). Connect wires to condenser and contact breaker terminals.

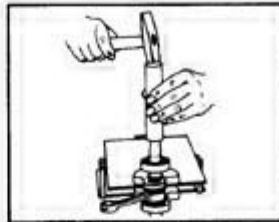

1

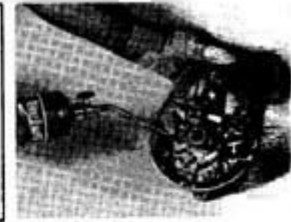

2A



2B

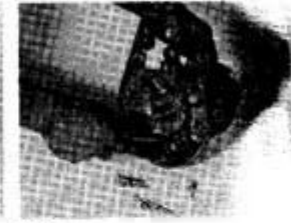

2C

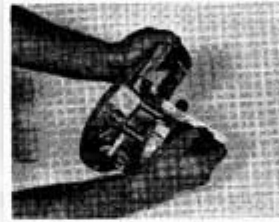

2D

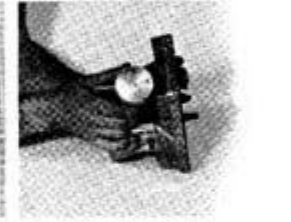

3A

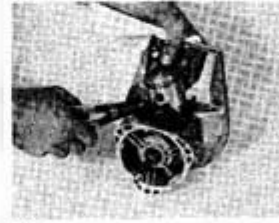

3B

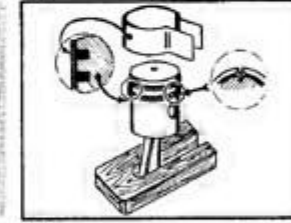

3C

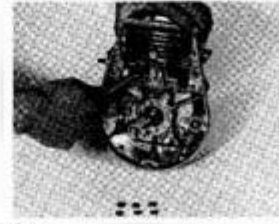

3D



3E

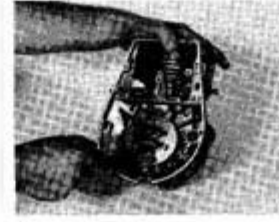

4



5

6. Flywheel

Insert and tap Woodruff key and align flywheel with keyway. Note: engine timing must be accomplished prior to installing the flywheel. Refer to Timing Procedure.

7. Spark Plug

Install spark plug using socket wrench.

8. Carrier Assembly

Insert carrier drum flush with flywheel, slipping the tabbed end of carrier into the interlocking flywheel recess (to prevent independent rotation of carrier drum). Install washer and hex nut and tighten against engine compression.

9. Fan Cover and Recoil Starter

Using five slotted screws, install fan cover—recoil starter housing. Do not overtighten or force screws.



6



7

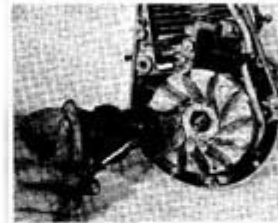

8



9

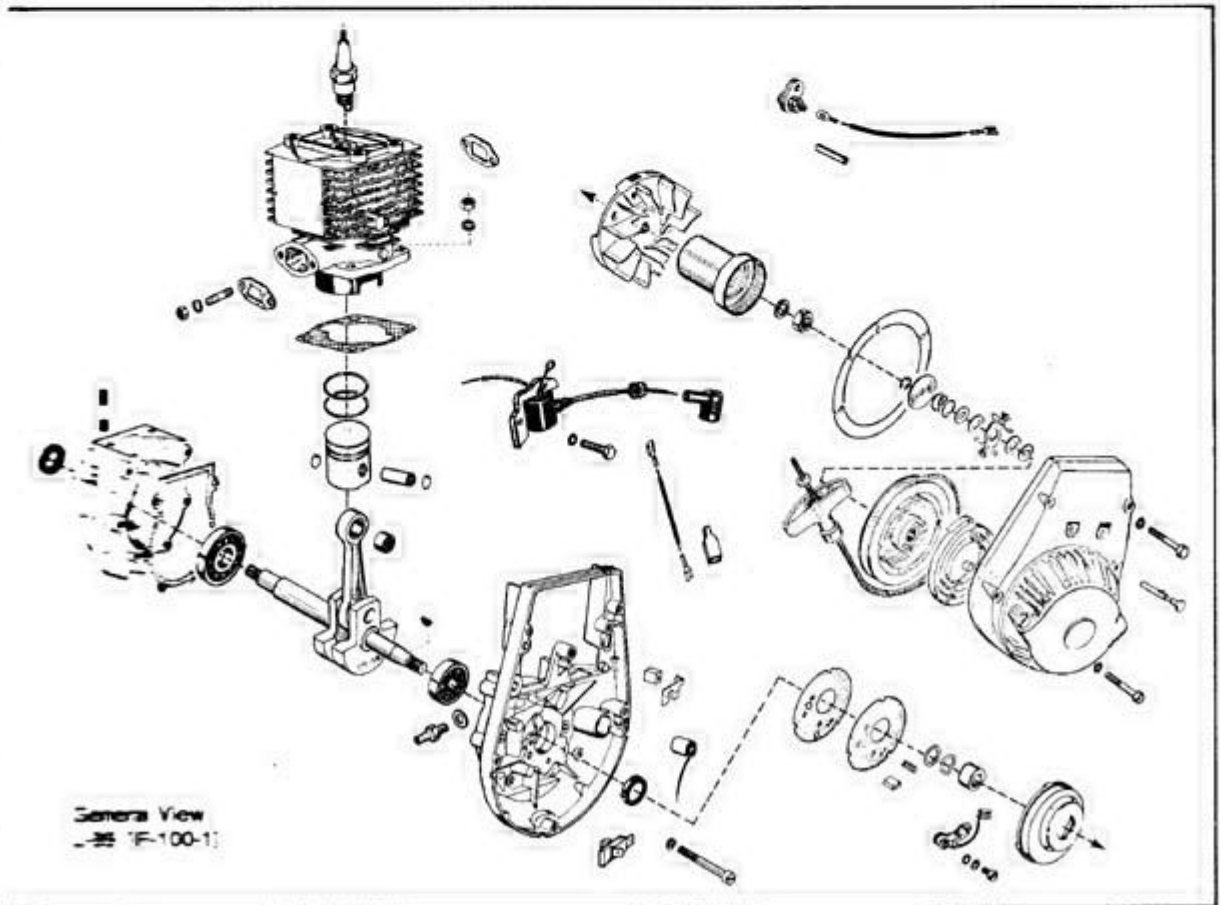



JLO Single Cylinder Engines

Disassembly and Assembly Procedure – Model L-99 (IF-100-1) Recoil Starter

Disassembly

- A. Remove circlip with screwdriver, lift out friction washers, spring and pawl assembly.
- B. Untie rope knot and remove handle.
- C. Place unit face-down on the workbench and gradually release rope tension.
- D. Remove rope pulley. Caution: recoil housing should face away from you to avoid injury from rapidly unwinding spring.
- E. Smack recoil housing down sharply against the workbench to release spring tension and enable you to gradually and safely uncoil it.

Assembly

1. Place starter housing face-up on workbench. Hook end of spring onto the small boss cast in the housing and rotate housing clockwise, slowly guiding the spring into position. Keep hand pressure on housing until spring is completely coiled.
2. Insert starter rope into pulley. Install rope pulley into housing and engage with rewind spring.
3. Turn pulley counterclockwise to the limit while holding the rope tightly between the housing and the outer edge of pulley. Maintain a firm grip with one hand and release pulley slowly until rope is in alignment with rope bushing in fan housing. Feed rope thru bushing and tie a temporary knot.
4. Install handle assembly and secure with a knot. Untie the temporary knot and let rope return to recoil housing.
5. Insert friction washers, pawl assembly, spring and cover-plate and fasten with a circlip.
6. Check for trouble free movement.

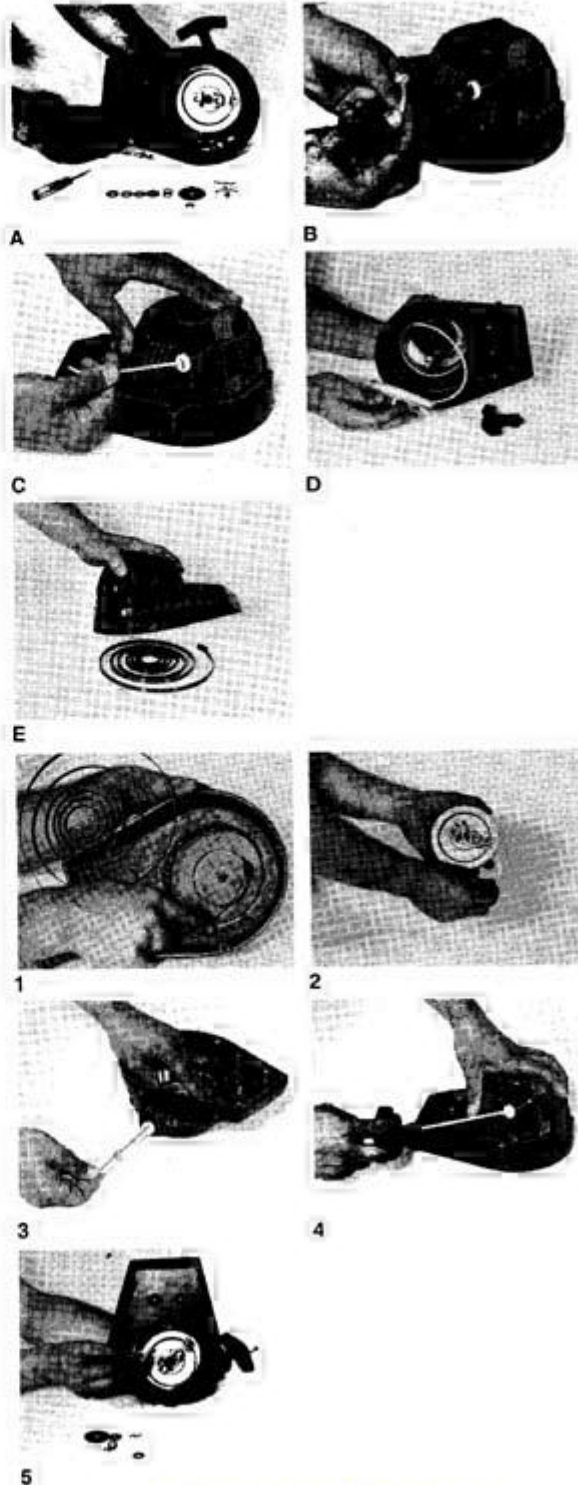

JLO Single Cylinder Engines

Timing Procedure - Model L-99 (IF-100-1)

NOTE: Flywheel must be removed before beginning timing procedure.

- A. Attach dial indicator to the cylinder head.
- B. Attach one lead of the ignition timing light to the black "kill" wire, the other to ground (engine casting).
- C. Bring piston to T.D.C.; adjust dial indicator to zero.
- D. Turn crankshaft counterclockwise (away from T.D.C.), closely observing dial indicator and timing light. When the piston reaches the timing point the light will dim, indicating the opening of the points. Check the dial indicator and, if timing does not agree with specifications, adjust the breaker point gap. To retard ignition decrease point gap; to advance it, increase gap. For best results, make adjustment within recommended tolerances.

Contact Breaker Gap:	.011" to .019"				
Ignition Setting Before T.D.C.	.082" to .098"				
Spark Plug Gap:	.016" to .020"				
Spark Plug:	<table border="1" style="display: inline-table; vertical-align: middle;"> <tr> <td style="padding: 2px;">Bosch</td> <td style="padding: 2px;">Champion</td> </tr> <tr> <td style="padding: 2px;">W-225-T-1</td> <td style="padding: 2px;">L-87-Y</td> </tr> </table>	Bosch	Champion	W-225-T-1	L-87-Y
Bosch	Champion				
W-225-T-1	L-87-Y				

- E. Adjustment of Ignition Coil/Flywheel Magneto Gap
The magnets which energize the coil are cast into the flywheel. The space between the laminated core and the magnets should measure .010" to .012". Do not use a steel feeler gauge. (this will demagnetize the magnets). Adjust by first loosening the two bolts holding the coil to the crankcase. Rotate the flywheel until the magnets are opposite the laminated coil core. Place gauge between magnets and core. Press down on ignition coil while tightening the two screws holding the coil.

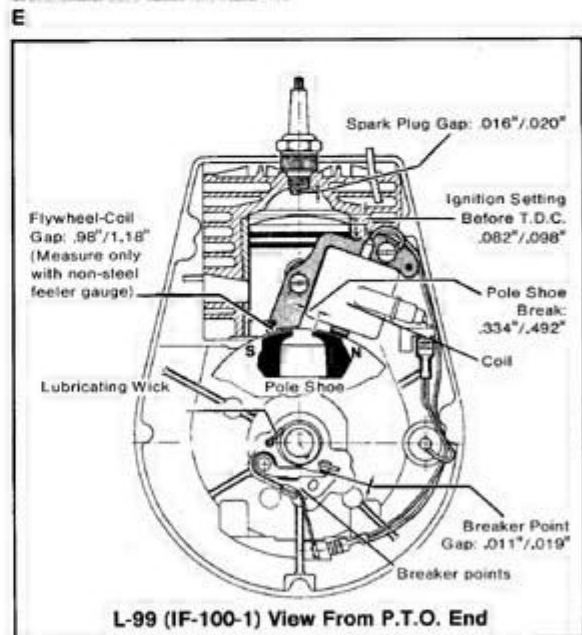
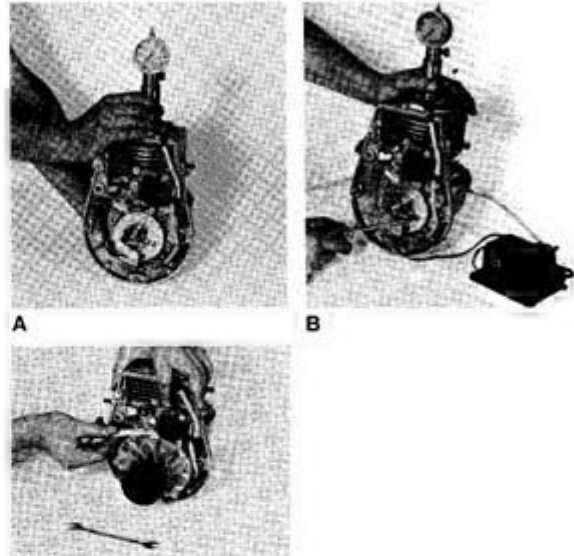

E



JLO Single Cylinder Engines

Disassembly and Assembly Procedure - Models L-230 (IF-250-1), L-227

Disassembly

A. Recoil Starter

Remove the three screws holding recoil to fan housing. Remove recoil assembly complete. For detailed service instructions, refer to Recoil Starter, Disassembly and Assembly.

B. Emergency Pulley

Remove three hexhead nuts and lift out pulley and gasket.

C. Air Shroud

Remove four nuts from cylinder head and lift off top of shroud. Remove exhaust and intake side shrouds by removing the exhaust flange and carburetor adapter.

D. Fan Housing

Remove six screws from the back of the fan house casting. (Use 10 mm. wrench for 4 screws, 13 mm. wrench for 2 screws). Note that one screw is slightly longer than the others; it holds the high tension wire clamp.

E. Flywheel Magneto

Make sure that spark plug is tight. Working against engine compression remove crankshaft nut with 24 mm. socket wrench by striking wrench a few sharp blows with a rubber or plastic hammer. Pull the flywheel with flywheel puller. Note that the threaded portion of the puller must be firmly engaged with that of the flywheel hub. Turn the puller bolt until it touches the tip of crankshaft. With a 24 mm. socket wrench, turn the puller bolt clockwise and extract the flywheel. Note that crankshaft key may come loose and stick to flywheel magnets.

F. Spark Plug

Remove spark plug with a socket wrench.

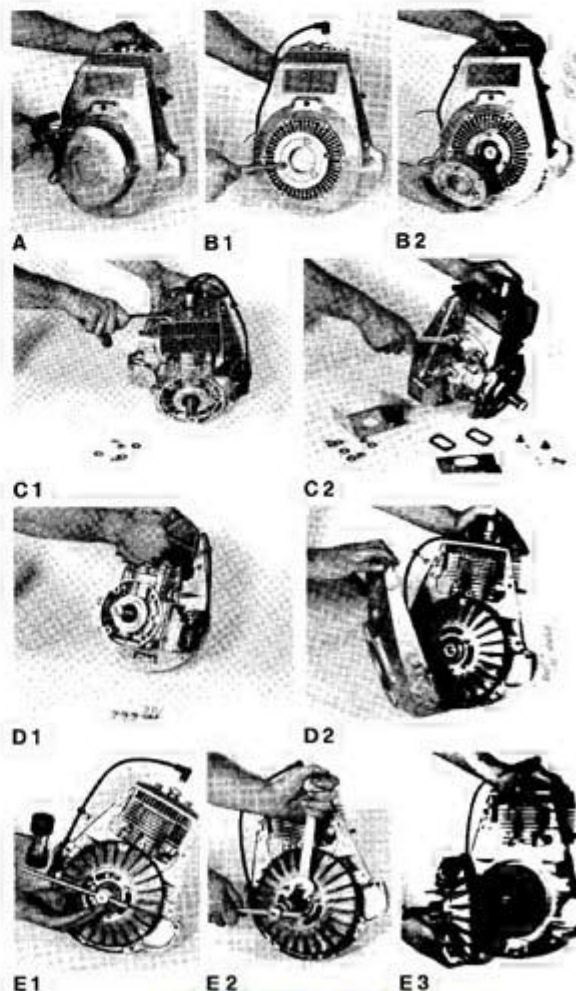

G. Cylinder Head

With 17 mm. socket wrench, remove 4 cylinder head nuts; take off spacers and cylinder head and gasket.

H. Cylinder

Remove the four cylinder base nuts with 13 mm. wrench. Gently lift up cylinder until piston clears the sleeve. Remove ignition coil.

I. Piston

With needle nose pliers remove the wrist pin circlips—one on each side of pin. Gently drive out the wrist pin and lift off the piston. Remove spacers and upper connecting rod bearing.

J. Armature Plate

Important: before pulling the armature plate make an alignment mark on it and on the crankcase to facilitate ignition timing. Remove the 2 slotted-head screws holding armature plate in place. Disconnect wire terminals from the external coil and clip them off. Put a drop of oil on the wires so they will slip easily through the protecting rubber grommet. Lift out the armature plate and pull wires through the grommet. Remove grommet.

K. Crankcase

To separate the crankcase: 1) remove 6 housing bolts (13 mm.); 2) turn crankcase on its side (ignition side facing up); 3) slide hollow protective pipe over oil seal (pipe should have I.D. slightly larger than oil seal); 4) using protective gloves, apply heat around bearing seat (do not overheat); 5) lift off, separating casting; 6) turn crankcase so P.T.O. end is up and proceed as per points 3, 4 and 5. Important: do not cut oil seal on sharp edges of crankshaft keyway. Should crankcase separate without application of heat, it is an indication that both crankcase castings are worn out and should be replaced.

L. Crankshaft

Place crankshaft on work surface and use special puller to remove bearings: 1) slide puller over crankshaft and align bolt with crankshaft end; 2) slip half shells around the bearing and engage them with puller grooves; 3) slide retaining ring over half shells to keep them on bearing; 4) use two 27 mm. wrenches and turn puller center bolt with one wrench while holding puller body with the other; 5) keep turning bolt clockwise until bearing comes to the end of crankshaft.

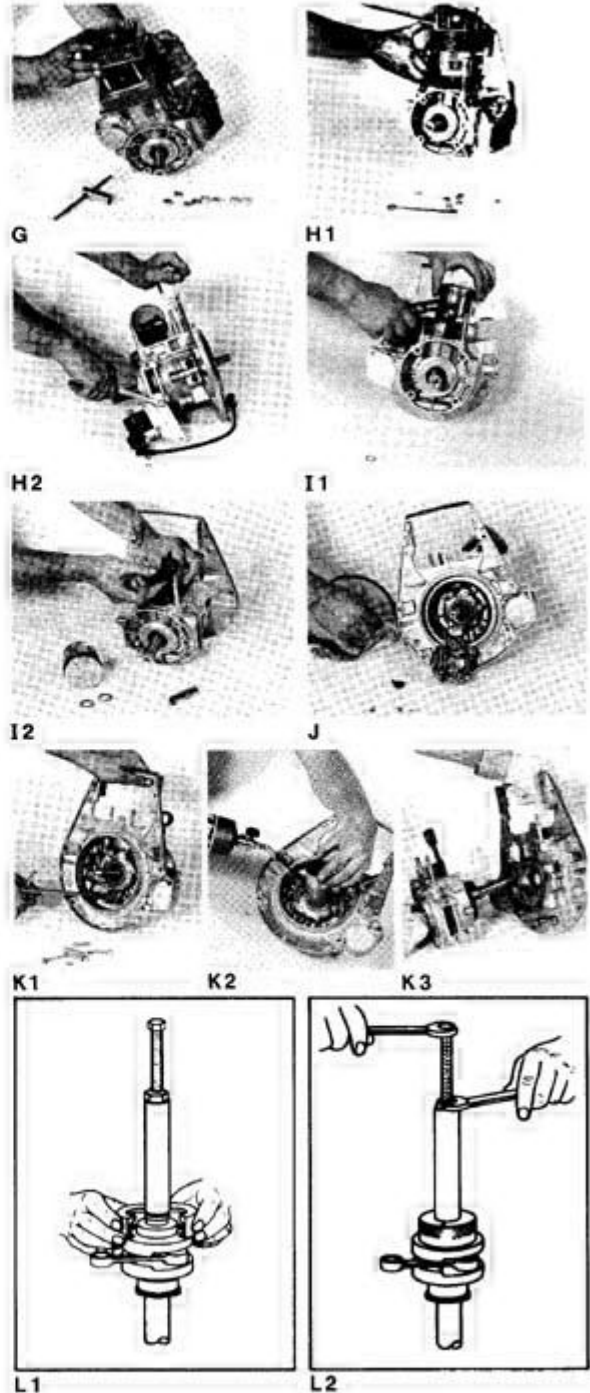



JLO Single Cylinder Engines

Disassembly and Assembly Procedure - Models L-230 (IF-250-1), L-227

Assembly

1. Crankshaft

Heat crankshaft bearings in oil preheated to 215°F. After reaching temperature, quickly slip bearing over end of crankshaft; it should fall freely on the counterweight. Using a hollow pipe with a diameter approximately that of the inner bearing race, hit pipe with a rubber hammer and seat the bearing on the shaft. The bearing should now rest securely and turn freely. Repeat procedure for bearing on other end of crankshaft.

2. Crankcase

Check both halves of crankcase and clean, carefully removing any left-over gasket material or burrs; 2) with the ignition side of the crankcase facing up, heat bearing seat area while protecting oil seal with a hollow pipe (see instructions K-3 and K-4; *disassembly*); 3) guide crankshaft through the oil seal until the bearing fits easily into its seat; 4) let casting cool, then install crankcase gasket; 5) to install the other half of the crankcase, repeat items 2, 3 and 4, as applicable; 6) insert the 6 bolts and tighten slightly; 7) check alignment of crankcase halves with a straight edge and 8) complete tightening the bolts, crosswise (7 ft./lbs.)

3. Piston and Cylinder

Clean carbon deposits from the piston. Check to see that rings move freely in their grooves. Install piston with the arrow pointing toward the exhaust port. Insert needle bearings into the connecting rod, then put a daub of grease on the rod so that the spacers installed later will adhere to it. Gently guide the piston over the connecting rod and insert the wrist pin. Snap circlips into each side of the piston using a screwdriver or needle-nose pliers. Install cylinder-base gasket. Place a V-shaped wood block under the piston, resting it on the crankcase. After lining up the rings with the locating pins on the piston, compress them with a ring compressor. Rest piston on wood block and carefully slide cylinder over the piston until the rings disappear into the cylinder. Remove ring compressor and wood block. Install cylinder base nuts and torque-down to specifications, crosswise (16/18 ft. lbs.).

4. Cylinder Head

Install cylinder head gasket, with the wide side of the metal ring facing up, then the cylinder head (the cooling fins should face in the direction of air flow). Install washers and nuts. Tighten (28/32 ft. lbs.).

5. Spark Plug

Install and tighten spark plug.

6. Armature Plate

Before installing the armature plate inspect it for loose connections, pinched wires, worn out contact breakers and defective condenser. (Note: the condenser is pressed into the plate and can be removed and replaced with a special Bosch tool). Install the rubber grommet and feed wires through it. Place armature in the original position marked in disassembly (instruction J) and fasten it using the three slotted screws. Attach the terminal clips to the wires and connect to the external coil.

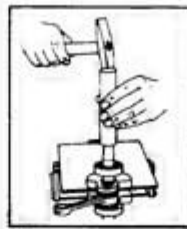

1A



1B



2A



2B



2C



2D

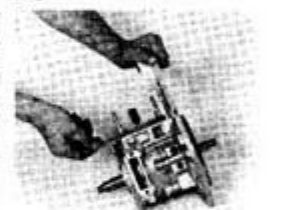

2E



3A

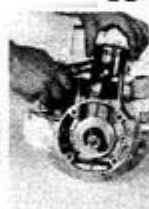

3B



3C



3D



4A

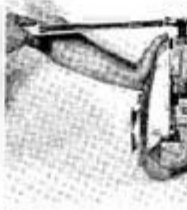

4B



6

7 Flywheel Magneto; Ignition Timing

Insert the keyway and install on crankshaft. Tighten flywheel nut. For timing refer to Timing Procedure.

8 Fan Housing

Insert the six screws through the back of the fan house casting. Install the longest of these screws on the upper right side of casting through the high tension wire clamp. Tighten all screws firmly and evenly.

9 Emergency Pulley

Insert gasket and emergency rope pulley.

10 Airshrouds

Insert top shroud first, using four 10 mm. nuts. Then, install the shroud for the intake side, making sure to place a gasket on both sides of the shroud and aligning the gaskets to prevent restriction of the impulse hole. Install shroud for the exhaust side, also placing one gasket on each side of shroud; attach the exhaust flange and tighten. (Note: Both the exhaust gasket and flange are of asymmetric design, therefore, exhaust gasket must be properly installed to avoid blocking exhaust).

11 Recoil Starter

Assemble the recoil starter to the engine using three hexhead screws, and lockwashers. For detailed service instructions refer to Recoil Starter, Disassembly and Assembly.

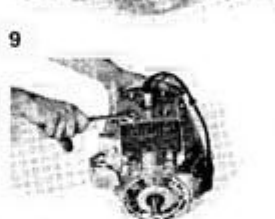
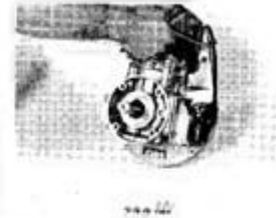
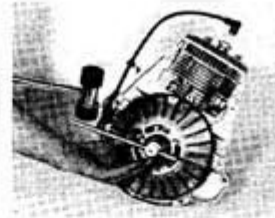

10 B

11

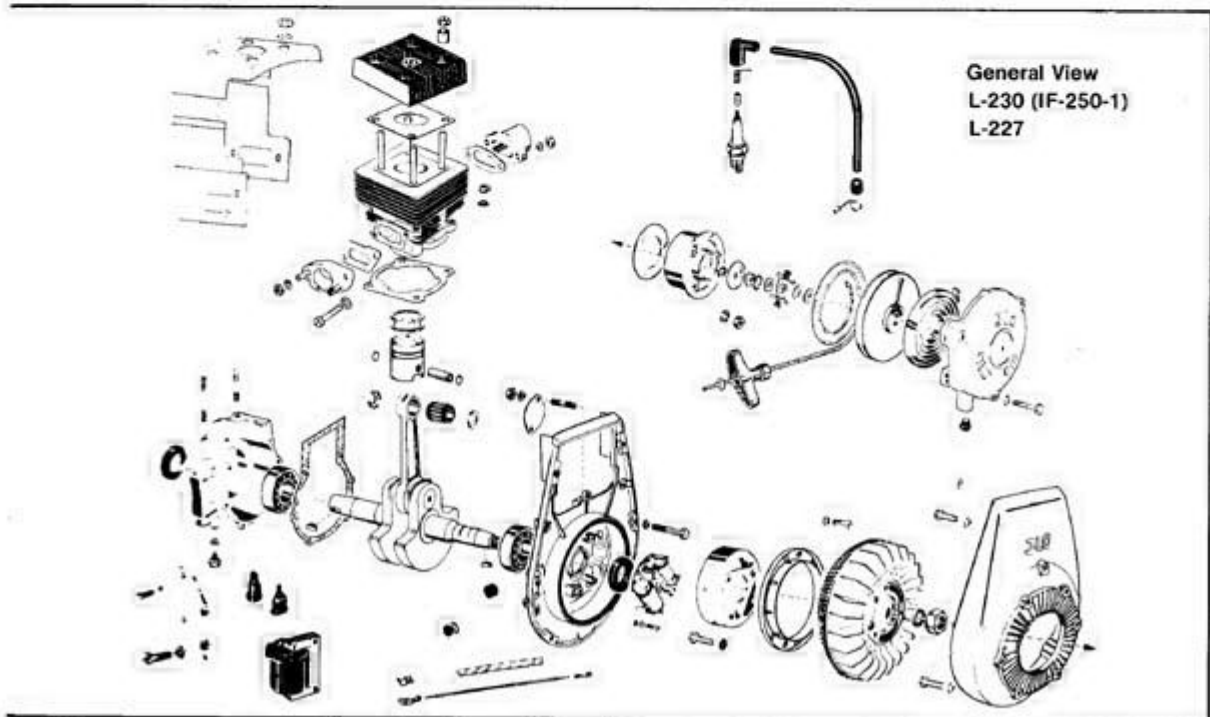

General View
L-230 (IF-250-1)
L-227



JLO Single Cylinder Engines

Disassembly and Assembly Procedure - Recoil Starter for Models L-230 (IF-250-1), L-227

Disassembly

A. Remove circlip with screwdriver; lift out friction washers, spring and pawl assembly.

B. Untie rope knot and remove handle.

C. Place unit on the workbench and gradually release rope tension. Remove rope pulley. Caution: recoil housing should face away from you to avoid injury from rapidly unwinding spring.

D. Turn recoil housing upside down in your hand and smack down sharply against the workbench to release spring tension and enable you to gradually and safely uncoil it.

Assembly

1. Place starter housing on workbench. Hook end of spring onto the small boss cast in the housing and rotate housing clockwise, slowly guiding the spring into position. Keep hand pressure on housing until spring is completely coiled.

2. Insert starter rope into pulley. Install rope pulley into housing and engage with rewind spring.

3. Turn pulley counterclockwise to the limit while holding the rope tightly in the notch. Maintain a firm grip with one hand and release pulley slowly until notch is in alignment with rope outlet in fan housing. Feed rope thru outlet and tie a temporary knot.

4. Install handle assembly and secure with a knot. Untie the temporary knot and let rope return to recoil housing.

5. Insert friction washers, pawl assembly, spring and cover-plate and fasten with a circlip.

6. Check for trouble free movement.

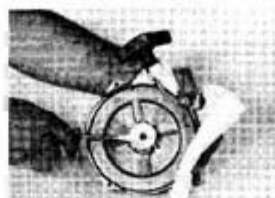

A 1

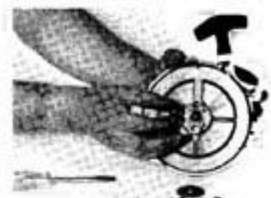

A 2



B



C



D



1

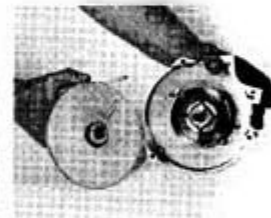

2



3



4

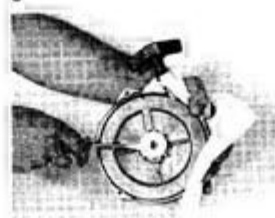

5

JLO Single Cylinder Engines

Timing Procedure For Models L-230 (IF-250-1), L-227

The engine has a fixed cam and it may be timed with flywheel on or off. Remove the recoil starter and emergency pulley and proceed as follows:

- A. Attach dial indicator to cylinder head.
- B. With flywheel on, turn flywheel clockwise until piston is at T.D.C. and adjust dial to zero. If the contact breaker is not accessible at this time, continue clockwise rotation until breaker points are visible through the flywheel opening. With feeler gage, check and adjust, if necessary, according to specifications.
- C. With flywheel removed: rotate crankshaft clockwise until piston is at T.D.C. and set dial to zero. Check breaker gap with feeler gage and adjust to specifications.
- D. Attach the lead of timing light to the black "kill" wire, the other to ground (engine casting).
- E. Turn crankshaft counterclockwise and away from T.D.C., loosely loosening dial indicator and timing light. When the piston reaches the timing point the light will dim indicating the opening of the points. Check the dial indicator and if timing does not agree with specifications, do not change the breaker point gap but, instead, adjust by loosening the armature plate and rotating complete assembly. Clockwise rotation will retard the ignition, counterclockwise will advance the ignition. Correct breaker gap will insure maximum ignition output.

Contact Breaker Gap:	.014" to .018"
Ignition Setting Before T.D.C.	.110" to .126"
Spark Plug Gap:	.016" to .020"
Spark Plug	

	Bosch	Champion
	M-260-T-1	K-7

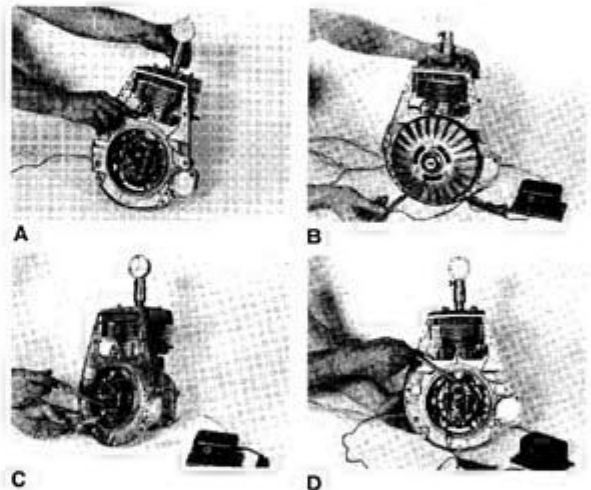
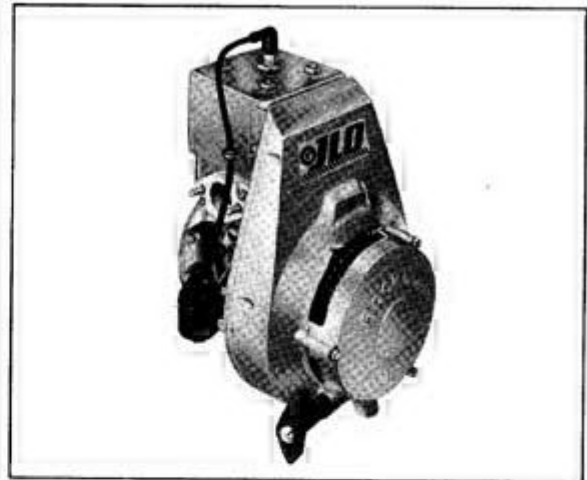



JLO Single Cylinder Engines

Disassembly and Assembly Procedure - Models L-295 (IF-295-1), L-340 (IF-340-1), R-295 (IF-295-2), R-340, (IF-340-2), L-297 and L-300.

Disassembly

A. Recoil Starter

Remove the four slotted screws holding recoil to fan housing. Remove recoil assembly complete. For detailed service instructions, refer to Recoil Starter, Disassembly and Assembly.

B. Emergency Pulley and Carrier Assembly

Remove three hexhead screws and pull out dust seal, carrier, emergency pulley and shims.

C. Air Shroud Assembly

Remove three nuts from cylinder head and lift off top of shroud. Remove exhaust and intake side shrouds by first removing the exhaust flange and carburetor adapter.

D. Fan Housing

With a 10 mm. wrench, remove six screws from the back of the fan house casting. Note that one screw is slightly longer than the others; it holds the high tension wire clamp. Be sure to insert it in the same hole when reassembling.

E. Flywheel Magneto

Make sure that spark plug is tight. Working against engine compression, remove crankshaft nut with 27 mm. socket wrench by striking wrench a few sharp blows with a rubber or plastic hammer. Pull the flywheel with a special flywheel puller. Note that the threaded portion of the puller must be firmly engaged with that of the flywheel hub. Turn the puller bolt until it touches the tip of crankshaft. With a 24 mm. socket wrench, turn the puller bolt clockwise and extract the flywheel. Note that crankshaft key may come loose and stick to flywheel magnets.

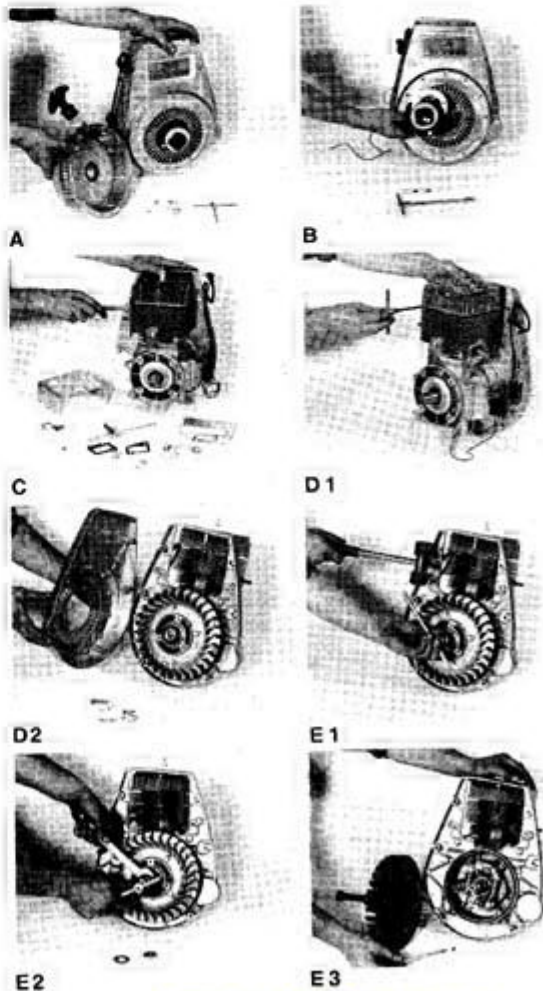
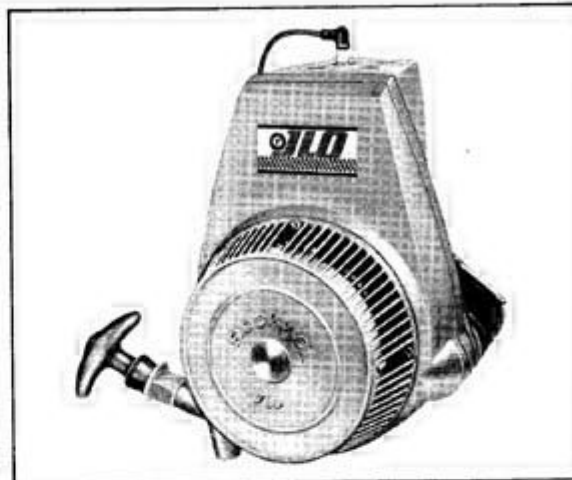

F. Spark Plug

Remove spark plug.

G. Cylinder Head

With 13 mm. socket wrench, remove cylinder head nuts; take off spacers and washers and lift-off cylinder head and gasket.

H. Cylinder

Remove the cylinder base nuts with 17 mm. wrench. Gently lift up cylinder until piston clears the sleeve.

I. Piston

With needle nose pliers remove the wrist pin circlips—one on each side of pin. Gently drive out the wrist pin and lift off the piston. Remove spacers and connecting rod bearing.

J. Armature Plate

Important: before pulling the armature plate make an alignment mark on it and on the crankcase to facilitate ignition timing. Remove the 3 slotted-head screws holding armature plate in place. Disconnect wire terminals from the external coil and clip them off. Put a drop of oil on the wires so they will slip easily through the protecting rubber grommet. Lift out the armature plate and pull wires through the grommet. Remove grommet.

K. Crankcase

To separate the crankcase: 1) remove the 6 Allen Head 8 mm. screws on the crankcase housing; 2) turn crankcase on its side (ignition side facing up); 3) slide hollow protective pipe over oil seal (pipe should have I.D. slightly larger than oil seal); 4) using protective gloves, apply heat around bearing seat (do not overheat); 5) lift off, separating casting; 6) turn crankcase so P.T.O. end is up and proceed as per points 3, 4 and 5. Important: do not cut oil seal on sharp edges of crankshaft keyway. Should crankcase separate without application of heat, it is an indication that both crankcase castings are worn out and should be replaced.

L. Crankshaft

Place crankshaft on work surface and use special puller to remove bearings: 1. slide puller over crankshaft and align bolt with crankshaft end; 2. slip half shells around the bearing and engage them with puller grooves; 3. slide retaining ring over half shells to keep them on bearing; 4. use two 27 mm. wrenches and turn puller center bolt with one wrench while holding puller body with the other; 5. keep turning bolt clockwise until bearing comes to the end of crankshaft. Note: On engines with internal threaded shafts use pressure piece (Part No. 444-31-690-00) to prevent damage to threads.



G



H

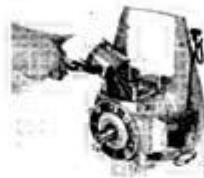

I1

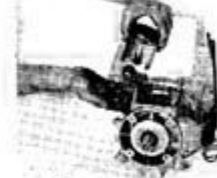

I2

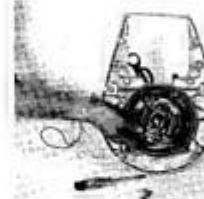

J

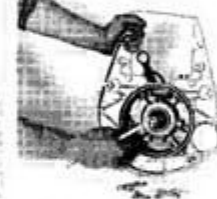

J1



K2



K3

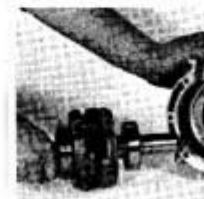

K4

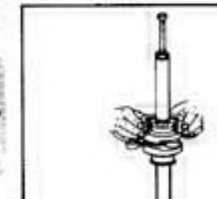

L1

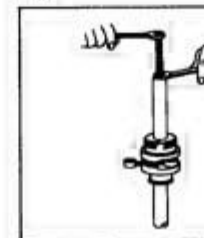

L2



JLO Single Cylinder Engines

Disassembly and Assembly Procedure - Models L-295 (IF-295-1), L-340 (IF-340-1), R-295 (IF-295-2), R-340 (IF-340-2), L-297 and L-300.

Assembly

1. Crankshaft

Heat crankshaft bearings in oil preheated to 215°F. After reaching temperature, quickly slip bearing over end of crankshaft; it should fall freely on the counterweight. Using a hollow pipe with a diameter approximately that of the inner bearing race, hit pipe with a rubber hammer and seat the bearing on the shaft. The bearing should now rest securely and turn freely. Repeat procedure for bearing on other end of crankshaft.

2. Crankcase

Check both halves of crankcase and clean, carefully removing any left-over gasket material or burrs; 2) with the ignition side of the crankcase facing up, heat bearing seat area while protecting oil seal with a hollow pipe (see instructions K-3 and K-4; *disassembly*); 3) guide crankshaft through the oil seal until the bearing fits easily into its seat; 4) let casting cool, then install crankcase gasket; 5) to install the other half of the crankcase, repeat items 2, 3 and 4, as applicable; 6) insert the 6 Allen Head screws and tighten slightly; 7) check alignment of crankcase halves with a straight edge and 8) firmly tighten the Allen Head screws, crosswise.

3. Piston and Cylinder

Clean carbon deposits from the piston. Check to see that rings move freely in their grooves. Install piston with the arrow pointing toward the exhaust port. Insert needle bearings into the connecting rod, then put a daub of grease on the rod so that the spacers installed later will adhere to it. Gently guide the piston over the connecting rod and insert the wrist pin. Snap circlips into each side of the piston using needle-nose pliers. Install cylinder-base gasket. Place a V-shaped wood block under the piston, resting it on the crankcase. After lining up the rings with the locating pins on the piston, compress them with a ring compressor. Rest piston on wood block and carefully slide cylinder over the piston until the rings disappear into the cylinder. Remove ring compressor and wood block. Install cylinder base nuts and torque-down crosswise (28/32 ft. lbs.).

4. Cylinder Head

Install cylinder head gasket, with the wide side of the metal ring facing up, then the cylinder head with the flat portion of the combustion chamber facing toward the exhaust port. Install washers and nuts. Tighten to specifications (16/18 ft. lbs.).

5. Spark Plug

Install and tighten spark plug.

6. Armature Plate

Before installing the armature plate inspect it for loose connections, pinched wires, worn out contact breakers and defective condenser. Note: the condenser is pressed into the plate and can be removed and replaced with a special Bosch tool. Install the rubber grommet and feed wires through it. Place armature in the original position marked in disassembly (instruction I) and fasten it using the three slotted screws. Attach the terminal clips to the wires and connect to the external coil.

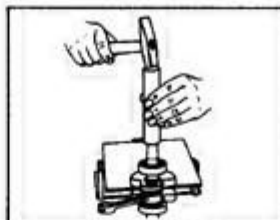

1



2A



2B

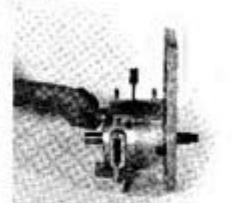

2C

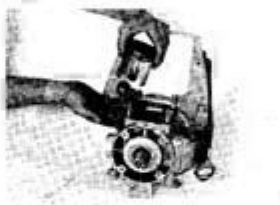

3A



3B

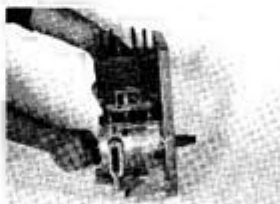

3C

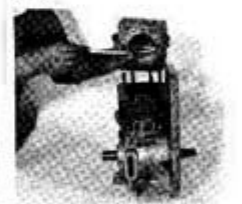

4A

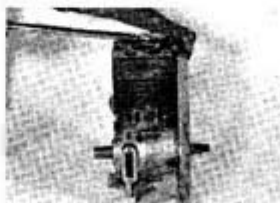

4B

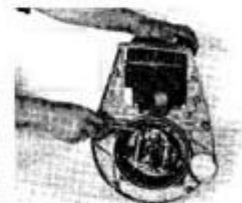

6

7. Flywheel Magneto; Ignition Timing

Align magnetic flywheel with keyway; insert and tap key into position. Tighten flywheel nut. For timing, refer to Timing Procedure.

8. Fan Housing

Insert the six screws through the back of the fan house casting. Install the longest of these screws on the upper right side of casting through the high tension wire clamp. Tighten all screws firmly and evenly.

9. Carrier; Emergency Pulley

Install emergency rope pulley, shims and carrier with three hexhead screws. Note that the shim plates go between the emergency pulley and carrier and are used to maintain the proper tolerance between the rope pulley and carrier. The dimension between the fan cover flange and top of carrier is 1.732 " plus or minus $.020$ ".

10. Airshroud Assembly

Install top shroud as follows: Place one washer on the respective cylinder head studs. Install top shroud. Place one washer on each of the studs protruding thru the air shroud. Install nuts and tighten. Then, install the shroud for the intake side making sure to place a gasket on each side of the shroud and align the gaskets to prevent restriction of the intake hole. Install shroud for the exhaust side, placing the gasket on each side of shroud; attach the exhaust flange and tighten.

11. Spark Plug

Install spark plug with a socket wrench.

12. Recoil Starter

Assemble the recoil starter to the engine using four hexhead screws and lockwashers. For detailed service instructions, refer to Recoil Starter, Disassembly and Assembly.

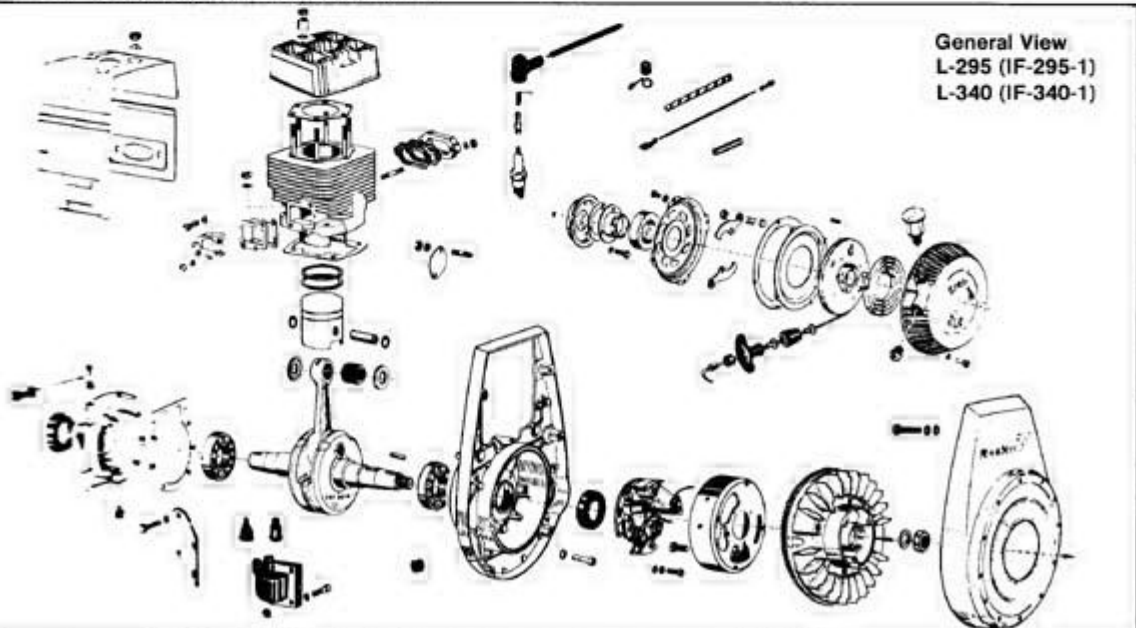
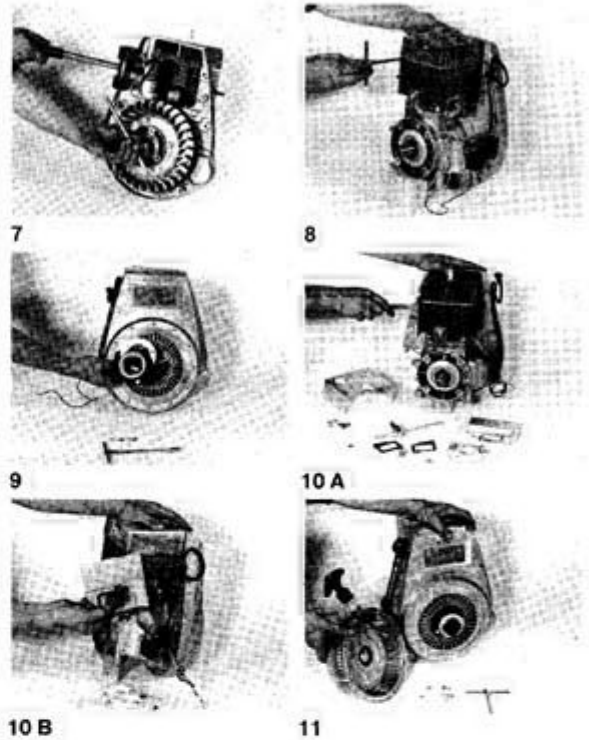



JLO Single Cylinder Engines

Disassembly and Assembly Procedure - Models L-295 (IF-295-1), L-340 (IF-340-1), R-295 (IF-295-2), R-340 (IF-340-2), L-297 and L-300.

Models R-295, R-340

These models have certain features which should be taken into consideration for proper servicing, as follows:

- A. These engines have an aluminum spacer on the P.T.O. end of the crankshaft between the bearing and crank web.
- B. Cylinder heads have angled dome with off-set spark plug hole. Spark plugs are long reach type (14 x 1.25 mm.)
- C. Three-piece air shrouds; top shroud slanted to accommodate long reach spark plug.
- D. Impeller assembly has curved fins.
- E. Cylinder base requires thin metal shims to maintain proper piston clearance.

The following procedure should be observed in reassembling these engines: When reassembling cylinder and head on the R-295 and R-340 engines, a tolerance of .059" and .071" (1.5 and 1.8 mm.) must be maintained between the top of the piston and the rim of the cylinder head.

To measure the tolerance insert a bent strip of solder about 1/8" diameter into the spark plug hole, and turn the crankshaft over top-dead-center several times. Measure the squeezed portion of the solder. Any deviation from the prescribed tolerance should be adjusted with the following metal shims inserted under the cylinder base.

Part No.	Thickness
295-07-009-00	.004" (0.1 mm.)
295-07-010-00	.012" (0.3 mm.)
295-07-011-00	.020" (0.5 mm.)

Assembly Sequence: Place one paper gasket for cylinder base over studs in crankcase, add number of compensating shims required and place another paper gasket for cylinder base. Put on cylinder over studs, add lockwashers and tighten nuts.

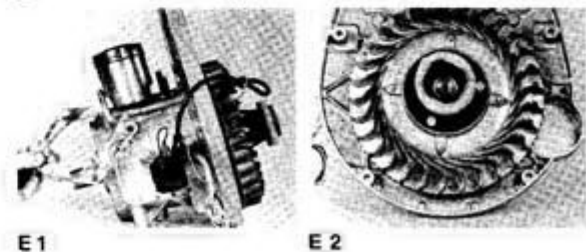
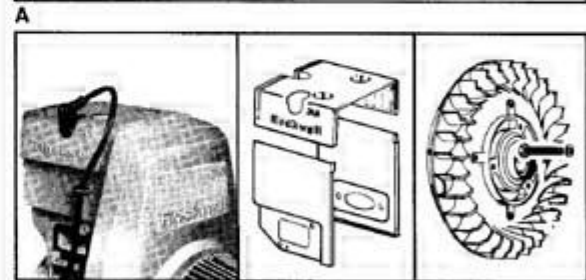
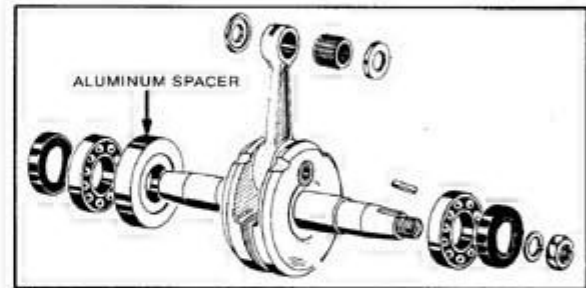

JLO Single Cylinder Engines

Disassembly and Assembly Procedure - Recoil Starter - Models L-295 (IF-295-1), L-340 (IF-340-1), R-295 (IF-295-2), R-340 (IF-340-2), L-297 and L-300

Disassembly

- A. Take off cover plate and gasket ring by removing four screws or Philipps head screws.
- B. Lift out pawl assembly, including spring caps and pressure springs.
- C. Remove intermediate plate.
- D. Remove handle assembly. To provide needed slack to remove handle, pull rope part way out and tie a knot.
- E. After removing handle, untie knot in rope carefully holding recoil pulley with one hand and let the rope feed back slowly to gradually release spring tension.
- F. Remove nylon rope bushing.
- G. Lift out rope pulley with pliers. Keep coil spring in position using a screwdriver.
- H. Turn recoil housing upside down in your hand and smack down sharply against workbench. This will release spring tension within the housing enabling you to grasp the spring and gradually and safely uncoil it.

Assembly

1. Insert recoil housing in jig and lower the hub, locking it in position with a cotter pin. Hook end of spring onto the boss cast in the housing and start rotating the housing clockwise, slowly guiding the spring into position. Complete the recoiling and remove housing from the jig.
2. With rope pulley in one hand and a Philip's screwdriver in the other, guide the screwdriver into the spring loop and engage the end of the spring on the pulley hub. The spring end must be properly seated on the pulley hub.
3. Before installing rope, turn rope pulley counterclockwise as far as possible. Backoff 1/2 to 3/4 of a turn. Align rope hole with outlet of starter housing and insert the rope. Install nylon bushing and handle assembly. Release tension while guiding the rope into the starter housing.
4. Install the Intermediate Plate.
5. Install Starter Pawl Assembly including springs and caps. Make sure that spring caps and springs are properly aligned to prevent binding.
6. Install gasket ring and cover plate.
7. Check the complete assembly for free play.

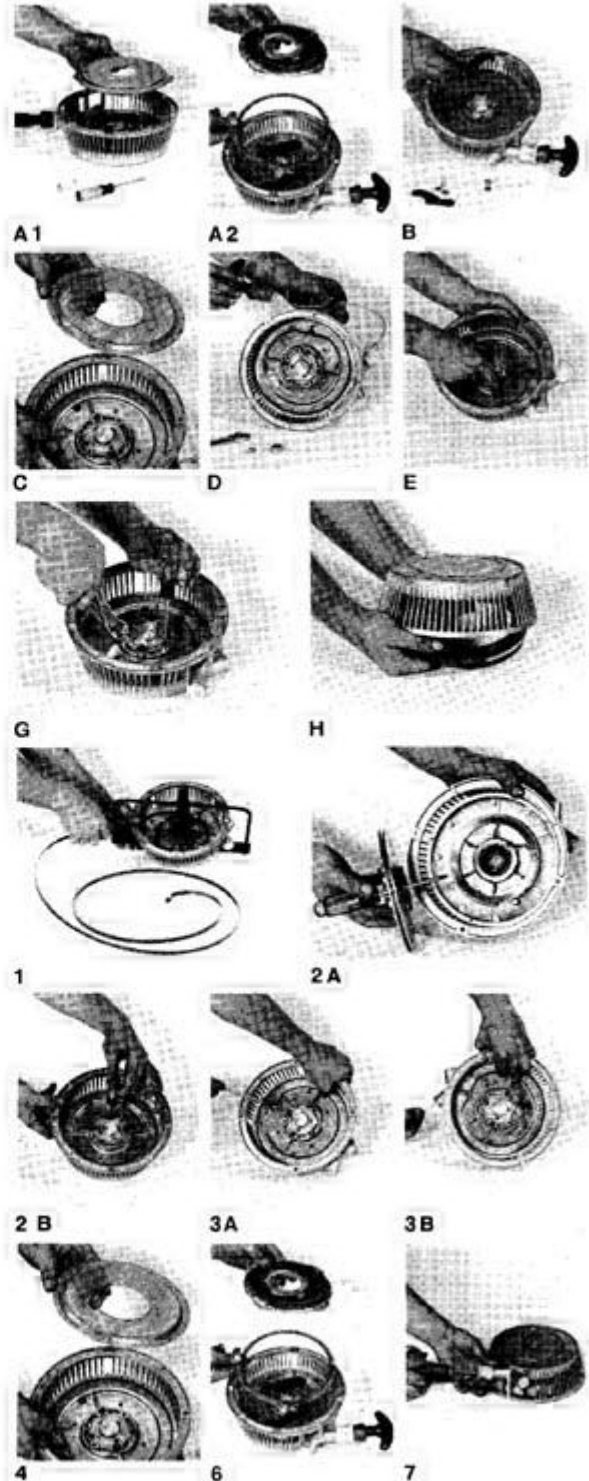



JLO Single Cylinder Engines

Electric Starter Mounting Instructions - Models L-295 (IF-295-1), L-340 (IF-340-1), R-295 (IF-295-2), R-340 (IF-340-2), L-297 and L-300.

Important: The following instructions apply only to engines prepared for electric start.

- A. Remove starter cover plate from crankcase.
- B. Insert forward end of electric starter in crankcase opening and tighten down the two nuts with a 13 mm. wrench.
- C. Attach support bracket at rear of starter using bolts and nuts provided and tighten. Note: In order to prevent starter from binding, place the two plain washers provided between the start bracket and the crankcase.

Note: to remove kit, reverse above procedure.

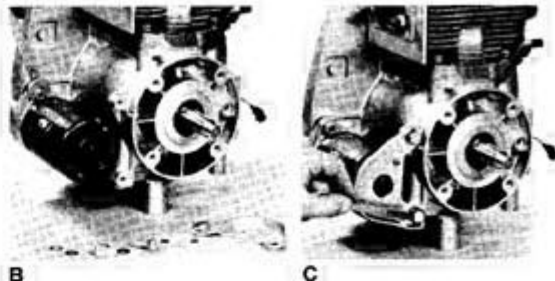

Timing Procedure For Models L-295 (IF-295-1), L-340 (IF-340-1), R-295 (IF-295-2), R-340 (IF-340-2), L-297 and L-300

Remove the recoil starter and carrier assembly and proceed as follows:

- A. Attach the dial indicator to the cylinder.
- B. Check point gap:
 1. **With Flywheel On:** Turn the flywheel clockwise to TDC (top dead center). If the contact breakers are not accessible at this time, continue clockwise rotation until the breaker points are visible. Use a clean feeler gauge to check the gap; if necessary, adjust according to specifications.
 2. **With Flywheel Off:** Use an old cam and rotate until the points are at their largest opening. Check gap and adjust, if necessary, to specifications.
- C. Advance the centrifugal weight. Hold in place using locking pin. (a tool specially designed for this purpose.)
- D. Attach one lead of the ignition timing light to the black "kill" wire, the other to ground (engine casting).
- E. Bring piston to TDC and adjust dial to zero.
- F. Turn flywheel counterclockwise (away from Top Dead Center), closely observing dial indicator and timing light. When the piston reaches the timing point the light will dim, indicating the opening of the points. Check the dial indicator and, if timing does not agree with specifications, do not change the breaker point gap but, instead, adjust by loosening the stator plate and rotating the complete assembly. Clockwise rotation will retard the ignition, counterclockwise will advance the ignition. Correct breaker gap will insure maximum ignition output.

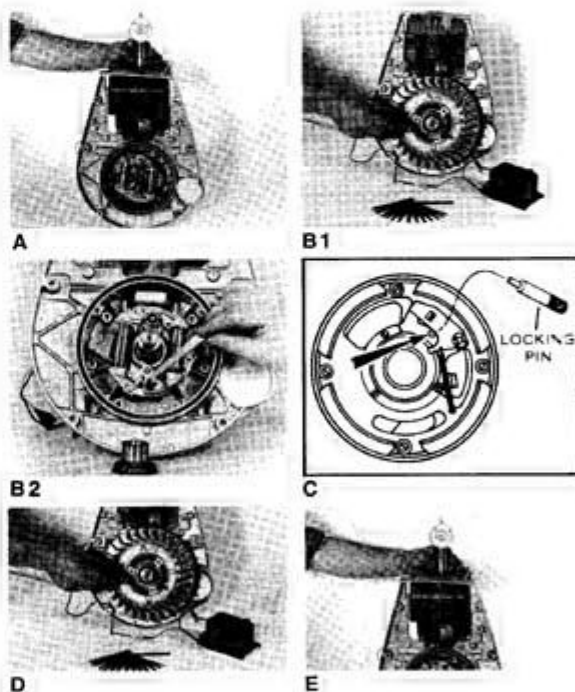

	L295, L340 L297, L300	R295 R340
Contact Breaker Gap	.014" to .118"	.014" to .118"
Spark Plug Gap	.118" to .138"	.140" to .160"
Spark Plug:	.016" to .020"	.016" to .020"
Bosch	M-240-T1	W-280-T20S
Champion	K-8	N-60Y

Please be aware of the misprints in the manual! (to the left)
 The first line is correct: contact Breaker Gap.
 The second line should read: Timing BTDC.
 The third line should read: Spark Plug Gap.
 The fourth and fifth lines are correct.
 All numeric values are correct.

JLO Twin Cylinder Engines

Disassembly and Assembly Procedure

Models LR-340/2 (2F-340-1), LR-399/2 (2F-400-1) and LR-440/2 (2F-440-2).

Disassembly

A. Recoil Starter

Remove four screws holding recoil to fan housing and the spacers and washers. Remove recoil assembly, complete. For detailed service instructions refer to Recoil Starter, Disassembly and Assembly.

B. Lower Fan Pulley and Carrier Assembly

Remove three hexhead screws on carrier. Remove dust seal, carrier, lower pulley halves and V-belt.

C. Upper Fan Belt Pulley Assembly

To keep impeller from turning, insert a punch through the fan housing and into the impeller body. With a 17 mm. wrench, remove fan nut. Pull out the loosened assembly—nut, washer, spacers, and upper pulley halves.

D. Flywheel Magneto

Make sure spark plugs are tight. Working against engine compression, with a 27 mm. wrench, remove crankshaft nut by striking wrench a few sharp blows with a hammer. To pull flywheel, attach special puller to flywheel flange, using three of the recoil starter screws previously removed. Screw into the three holes on flange and tighten. Turn puller until bolt touches tip of crankshaft. With a 24 mm. socket wrench, turn puller bolt clockwise and extract flywheel. Note that key may come loose and adhere to the flywheel magnets.

E. Intake Manifold

Remove the four nuts holding manifold and the two lower coil cover screws. Take off manifold and coil cover. Remove screw holding spark plug wires to side of fan housing.

F. Fan Housing; Armature Plate

Disconnect solid blue and blue-yellow coil wires. With a metric Allen Head wrench, remove the 4 socket cap screw holding fan housing to crankcase. To loosen, place unit with fan housing protruding over end of workbench and, holding housing with one hand, hit light but sharp blows around edge of housing. Pull housing straight out past the crankshaft careful not to cut the oil seal on the keyway. From front of fan housing, drive out shaft and fan. The fan housing bearings may now be removed by punching out from the side opposite that from which they are normally inserted. Remove bearing spacer.

The armature plate is attached to the fan housing by two slotted screws and can be removed at this time. Scratch-mark its original position before removing to facilitate engine timing.

G. Spark Plugs

Remove with a socket wrench.

H. Cylinder Heads

With 17 mm. wrench remove head nuts and lift head and gasket from cylinder block. Mark cylinder head and corresponding cylinder in order to assure proper reassembly. The number closest to the P.T.O. end is always considered the first cylinder. Repeat operation for second cylinder.

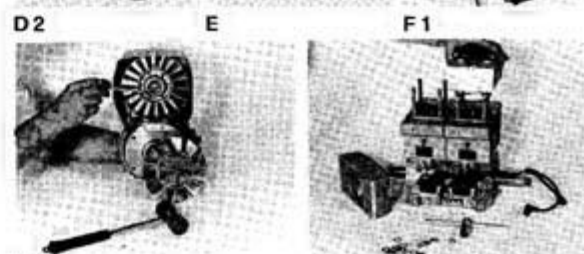
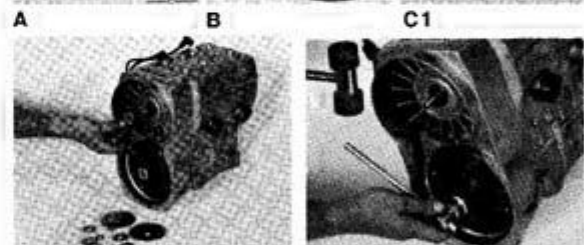
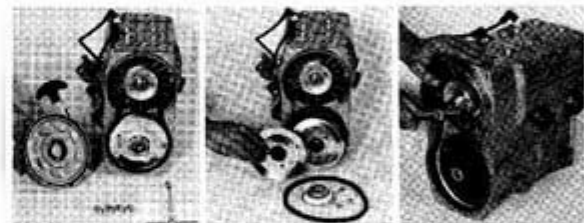
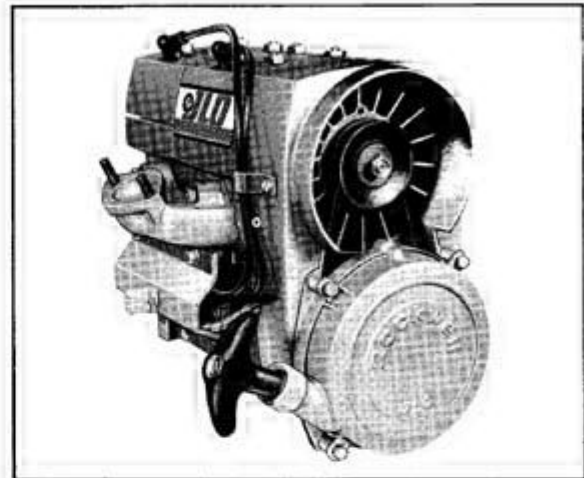

F2 H



JLO Twin Cylinder Engines

Disassembly and Assembly Procedure -

Models LR-340/2 (2F-340-1), LR-399/2 (2F-400-1) and LR-440/2 (2F-440-2).

Disassembly

I. Cylinders

Lay unit on its side and with a 13 mm. socket remove the 8 cylinder-base nuts. (Unless complete disassembly is required, remove one cylinder at a time so as to maintain crankcase alignment). Set unit upright again and lightly tap cylinder with a rubber hammer and lift gently until piston clears the skirt. Repeat operation for second cylinder.

J. Piston and Wrist Pin

Prior to removing mark each piston in relation to the cylinder with which it mates. Use needle-nose pliers or special screw driver and remove circlips—(one circlip on each side). Gently drive out wrist pin. Repeat operation for piston No. 2. Remove ignition coils and spark plug wires.

K. Crankcase

To separate crankcase halves, hold upper shell with left hand and "rock" slightly back and forth to break the sealing surfaces. If necessary, strike side of crankcase with rubber hammer to complete the separation. Remove crankshaft.

L. Crankshaft; Crankshaft Bearings

With crankshaft on work surface, remove oil seal and alignment washer from P.T.O. end. Remove bearings using puller. Use pressure piece on P.T.O. end to avoid damaging internal threads. Slide puller body over crankshaft and align bolt with crankshaft end. Slip puller half-shells around the bearing and engage them on puller grooves. Slide retaining ring over half-shells to keep them on the bearing. Using two 27 mm. wrenches, turn puller center bolt with one wrench while holding puller body with the other. Keep turning puller center bolt clockwise until it pulls the bearing to the end of the crankshaft.

Assembly

1. Crankshaft

Heat crankshaft bearings in oil preheated to 215°F. After reaching temperature, quickly slip bearing over end of crankshaft; it should fall freely on the counterweight. Using a hollow pipe with a diameter approximately that of the inner bearing race, hit pipe with a rubber hammer and seat the bearing on the shaft. The bearing should now rest securely and turn freely. Repeat procedure for bearing on other end of crankshaft.

2. Crankcase

Inspect both halves of crankcase and clean carefully removing any left-over adhesive or burrs. Apply Permatex type sealing compound to lower crankcase shell sealing surfaces and a little bit on the bearing surfaces. (Note: no seal gaskets used). Place crankshaft in lower shell and align spacers with machined grooves. Place oil seal on P.T.O. end of shaft, flush with the casting. Turn crankshaft with your hand to check freedom of movement and make sure that the oil seal is seated. Install upper crankcase shell and seat by tapping it lightly.

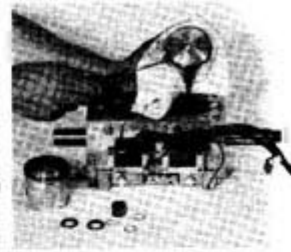
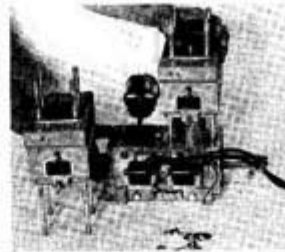

J 1

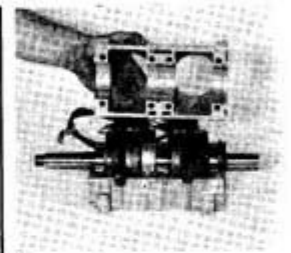

J 2

K

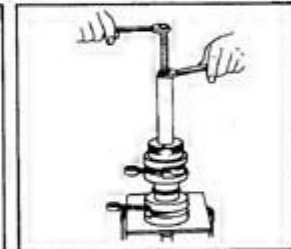
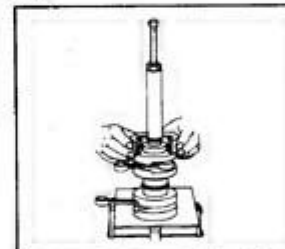

L-1

L-2

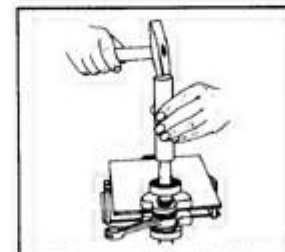

1

2

3. Piston and Cylinder

Clean carbon deposits from the piston. Check to see that rings move freely in their grooves. Mate piston with corresponding cylinder. The piston must be installed with the arrow pointing toward the exhaust port. Insert needle bearings into the connecting rod, then place a daub of grease on the connecting rod so that the spacers installed later will adhere to it. Gently guide the piston over the connecting rod and insert the wrist pin. Snap circlips into each side of the piston, open end towards the top of the piston, using a screwdriver or needle-nose pliers. Install cylinder base gasket. Place a V-shaped wood block under the piston, resting it on the crankcase. After lining up the rings with the locating pins on the piston, compress them with a ring compressor. Rest the piston on the wood block and carefully slide the cylinder over the piston until the rings disappear into the cylinder. Remove ring compressor and wood block. Repeat procedure for second cylinder. Turn the unit over on its side and install the cylinder base nuts and tighten lightly. Assemble the intake manifold and tighten the four nuts. Draw nuts tightly in order to evenly align both cylinders. Before tightening cylinder base nuts align crankcase halves by installing the fan housing or using a straight edge. Turn unit completely over and torque-down the cylinder base nuts to 16/18 ft. lbs., crosswise and then remove fan housing. Remove the manifold assembly previously installed only to align the cylinders.

4. Impeller; Fan Housing Bearings

Install snap rings one on each side of housing. Install one bearing, making sure sealed surface faces outward. Pack fan bearing housing with grease. Install bearing spacer, then the second bearing. Slide shaft through impeller and install Nilos ring on the side of the impeller which faces the housing, and then through the bearings.

5. Fan Housing; Armature Plate

Install the armature plate aligning it with the scratch marks previously put on during disassembly. Tighten slotted screws. Check the wiring protruding from the fan housing to make sure that there are no broken wires. Slip the rubber grommet protecting the wires into the housing. Check the O-ring on the back side of the fan housing and the oil seal for cuts or other visible damage. Pass the fan housing over the crankshaft and avoid hitting the sharp edges of the keyway. Adjust the housing against the crankcase and insert the four screws with a metric Allen Head wrench. Tighten Allen Head screws crosswise.

6. Intake Manifold; Coil Cover

Install ignition coils, gaskets and intake manifold. Tighten the two upper manifold nuts. Connect the ignition coil wires to terminals. Replace coil cover making sure to reconnect the No. 1 cylinder ground wire (brown). Fasten spark plug wire to fan housing.

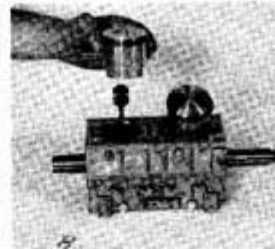

3A

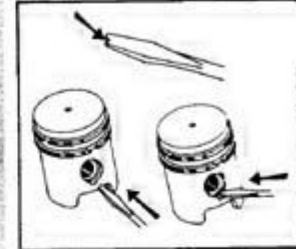

3B

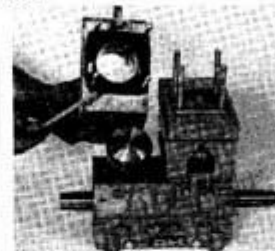

3C



3D

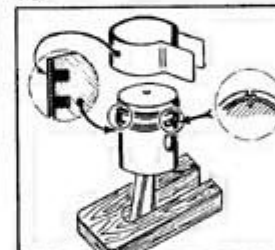

3E

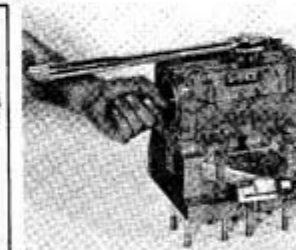

3F

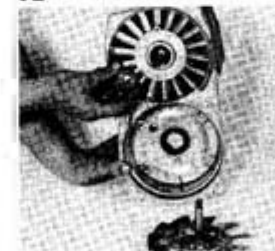

4A

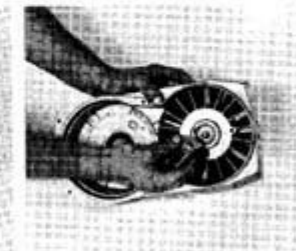

4B



5

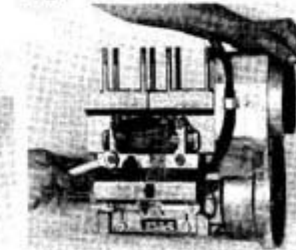

6



JLO Twin Cylinder Engines

Disassembly and Assembly Procedure -

Models LR-340/2 (2F-340-1), LR-399/2 (2F-400-1) and LR-440/2 (2F-440-2).

Assembly

7. Upper Fan Belt Pulley Assembly

Insert Nilos ring, first tapered spacer (dished side towards fan), first pulley half, four adjustment shims, second pulley half, second tapered spacer (dished side facing outward), washer and nut. Note: block impeller with a punch when tightening nut.

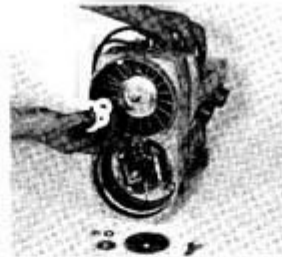

8. Flywheel Magneto; Ignition Timing

Align magnetic flywheel with keyway, insert and tap key into position. Lightly tighten flywheel nut. For timing, refer to Timing Procedure.

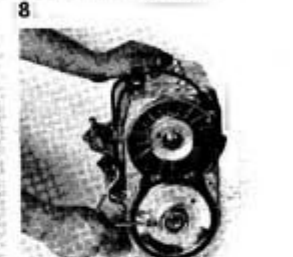

9. Cylinder Heads

Install cylinder head gaskets with the wide side of the metal ring facing up. Assemble cylinder heads with corresponding cylinders and install washers and nuts. Tighten to 28/32 ft. lbs.

10. Spark Plugs

Install and tighten spark plugs. Complete tightening of flywheel nut (25/29 ft. lbs.).

11. Lower Fan Belt Pulley Assembly

Install the first pulley half with dished side facing the housing, the fan belt, the second pulley half with the dished side facing out and the carrier assembly. Tighten carrier screws while slowly rotating the crankshaft with your hand to prevent squeezing the fan belt. Install dust seal.

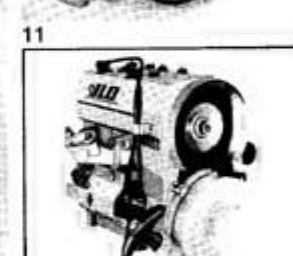
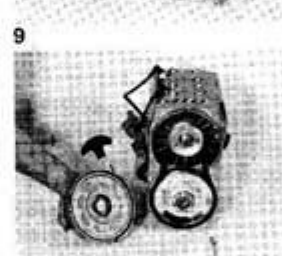

12. Recoil Starter

Install recoil starter assembly using the four hexhead screws, clamps and lockwashers. For detailed service instructions, refer to Recoil Starter, Disassembly and Assembly.

Electric Starter Mounting Instructions

Models LR-340/2 (2F-340-1), LR-399/2 (2F-400-1) and LR-440/2 (2F-440-2).

Ring Gear Kit

A. With screwdriver, pry out oil seal from P.T.O. end.

B. Remove rubber protective band from ring gear hub. Insert new, larger seal flush with the crankcase.

C. Lightly grease ring gear hub and slide ring gear onto crankshaft.

D. Install the two ring gear wedge rings as follows: first, insert the smaller of the two rings into the ring gear opening with the tapered end facing you; then the larger ring with the tapered end facing the engine.

E. Insert pressure flange and tighten.

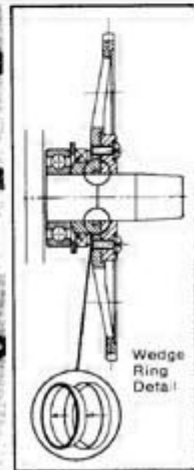
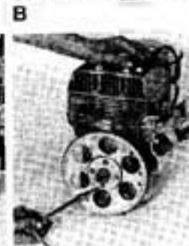
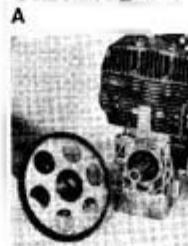
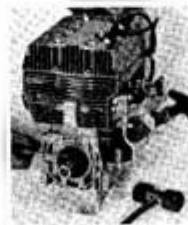



JLO Twin Cylinder Engines

Electric Starter Mounting Instructions

Models LR-340/2 (2F-340-1), LR-399/2 (2F-400-1) and LR-440/2 (2F-440-2).

Electric Starter Kit Installation

1. Install front mounting bracket on crankcase using the two socket cap screws provided.
2. Loosely install rear support bracket to crankcase housing.
3. Insert starter unit between front and rear brackets and fasten securely to front bracket.
4. Tighten rear bracket to crankcase housing and then fasten rear bracket to motor.

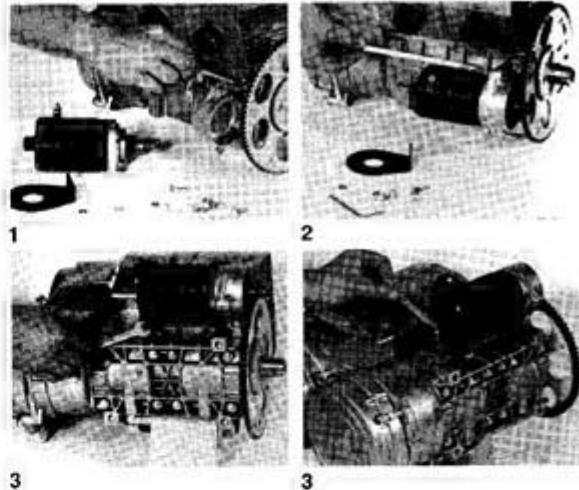

Removal

1. To remove, reverse the above procedure.

Disassembly and Assembly Procedure - Recoil Starter for Models LR-340/2 (2F-340-1), LR-399/2 (2F-400-1) and LR-440/2 (2F-440-2)

Disassembly

- A. Take off cover plate and gasket ring by removing slotted or Philips head screws.
- B. Lift out pawl assembly, including spring caps and pressure springs.
- C. Remove intermediate plate.
- D. Remove handle assembly. To provide needed slack for removal of handle, pull rope part way out and tie a knot.
- E. After removing handle, untie knot in rope carefully holding recoil pulley with one hand and let the rope feed back slowly to gradually release spring tension.
- F. Remove nylon rope bushing.
- G. Lift out rope pulley with pliers. Keep coil spring in position using a screwdriver.
- H. Turn recoil housing upside down in your hand and smack down sharply against workbench. This will release spring tension within the housing enabling you to grasp the spring and gradually and safely uncoil it.

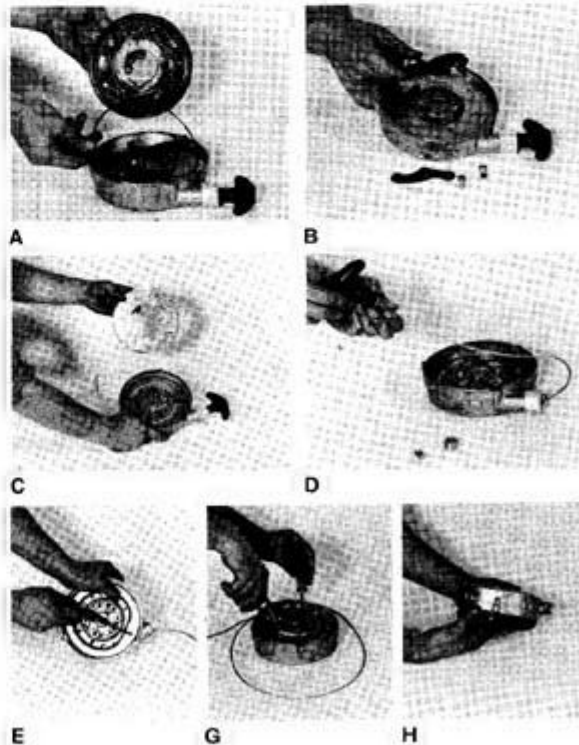



JLO Twin Cylinder Engines

Disassembly and Assembly Procedure - Recoil Starter

Models LR-340/2 (2F-340-1), LR-399/2 (2F-400-1) and LR-440/2 (2F-440-2)

Assembly

1. Insert recoil housing in jig and lower the hub, locking it in position with a cotter pin. Hook end of spring onto the small boss cast in the housing and start rotating the housing clockwise, slowly guiding the spring into position. Complete the recoiling and remove housing from the jig.

2. With rope pulley in one hand and a Philipp's screwdriver in the other, guide the screwdriver into the spring loop and engage the end of the spring on the pulley hub. The spring loop must be properly seated on the pulley hub.

3. Before installing rope, turn rope pulley counterclockwise as far as possible. Back-off 1/2 to 3/4 of a turn. Align rope hole with outlet of starter housing and insert the rope. Install nylon bushing and handle assembly. Release tension guiding the rope into the starter housing.

4. Install the Intermediate Plate.

5. Install starter pawl assembly including springs and caps. Make sure that spring caps and springs are properly aligned to prevent bending. (Install ball shaped cap last).

6. Install gasket ring and cover plate.

7. Check the complete assembly for free play.

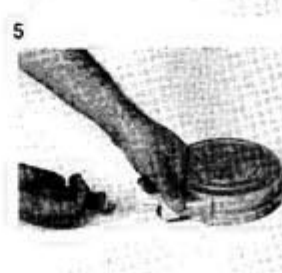
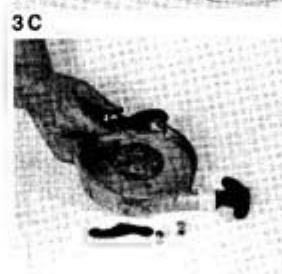
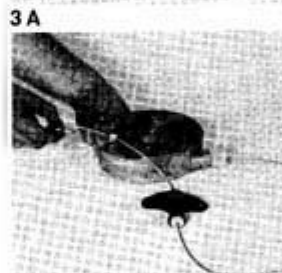
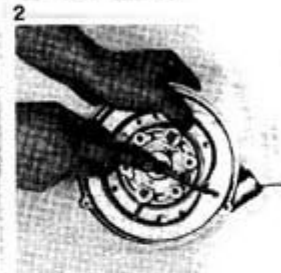
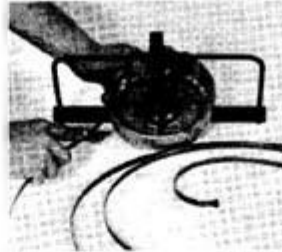

JLO Twin Cylinder Engines

Timing Procedure

Models LR-340/2 (2F-340-1), LR-399/2 (2F-400-1) and LR-440/2 (2F-440-2)

With the recoil starter, carrier assembly and lower pulley halves removed, proceed as follows:

A. Remove cylinder heads and attach the dial indicator to cylinder No. 1.

B. Turn the flywheel clockwise towards TDC (top dead center) until breaker points are visible. Use a clean feeler gauge and adjust the gap. Note: if flywheel is removed, use an old cam and rotate until the points are at their largest opening. Check gap and adjust to specifications as necessary. Repeat procedure for the other set of points.

C. Advance the centrifugal weight. Hold in place using locking pin, (a tool specially designed for this purpose.)

D. Attach one lead of the ignition continuity light to terminal of No. 1 cylinder coil, the other to ground (engine casting). For the second cylinder, attach continuity light lead to No. 2 cylinder coil terminal, (solid blue wire is for No. 1 cylinder; blue-yellow wire is for No. 2 cylinder).

E. Bring piston of No. 1 cylinder to TDC and adjust dial to zero.

F. Turn flywheel counterclockwise (away from TDC), closely observing dial indicator and timing light. When piston reaches the timing point, the light will dim indicating the opening of the points. Now, check the dial indicator. If timing does not agree with specifications, do not change the breaker point gap; adjust by loosening and rotating armature plate assembly (illus. F). Rotate assembly clockwise to retard, counterclockwise to advance the ignition. Correct breaker point gap will insure maximum ignition output. **Important: to time cylinder No. 2 repeat procedure for cylinder No. 1 except do not rotate armature plate.** If timing of No. 2 cylinder is required, adjust the breaker point gap only.

Contact Breaker Gap:	.014" to .018"	
Ignition Setting Before T.D.C.	.083" to .102"*†	
Spark Plug Gap:	.016" to .020"	
Spark Plug:	<i>Bosch</i>	<i>Champion</i>
	W-260-T-2	N-3

*Cam fully advanced. †Applies to all current axial-fan twin-cylinder models. However, on LR-340/2 models with serial numbers up to and including No. 14850, and on LR-399/2 models with serial numbers up to and including No. 30296, the ignition setting is .104" to .124" before T.D.C.

NOTE: Rockwell-Jlo axial-fan twin cylinder engines have timing marks cast on the fan housing. This makes it possible to check timing while the engine is running. Use an automotive type strobe light and aim at the timing mark on left. If the notches on the flywheel are not in alignment with the marks on the fan housing, the engine is out of time. Note that there are two notches on the flywheel—one for each cylinder. This permits instant timing check of both cylinders.

A quick timing check can also be performed with the engine not running. With centrifugal weight in retard position, attach the timing tester to the coil wire terminals and slowly turn the engine over by pulling on the recoil starter. Once the notch on the flywheel is aligned with the mark on the right, the timing tester light should dim. If the light does not dim when both timing marks are in alignment, the engine needs retiming.

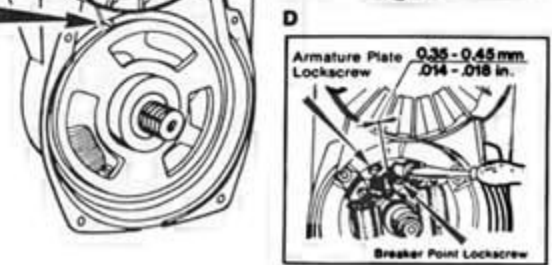
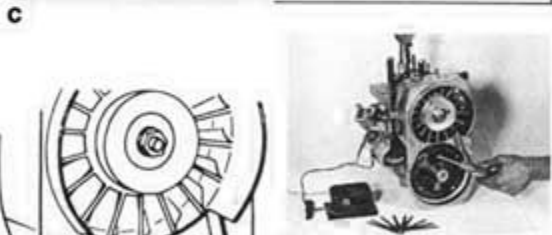
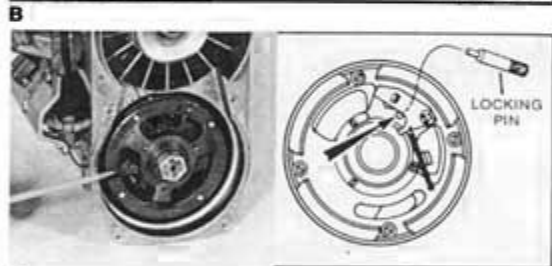
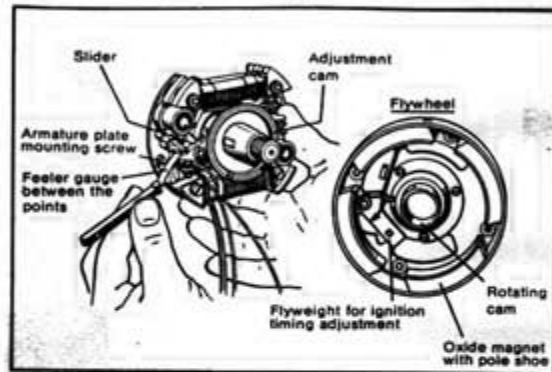
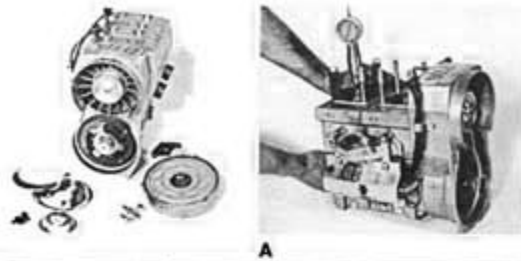

F



JLO Twin Cylinder Engines

General View - Models LR-340/2 (2F-340-1), LR-399/2 (2F-400-1) LR-440/2 (2F-440-1)

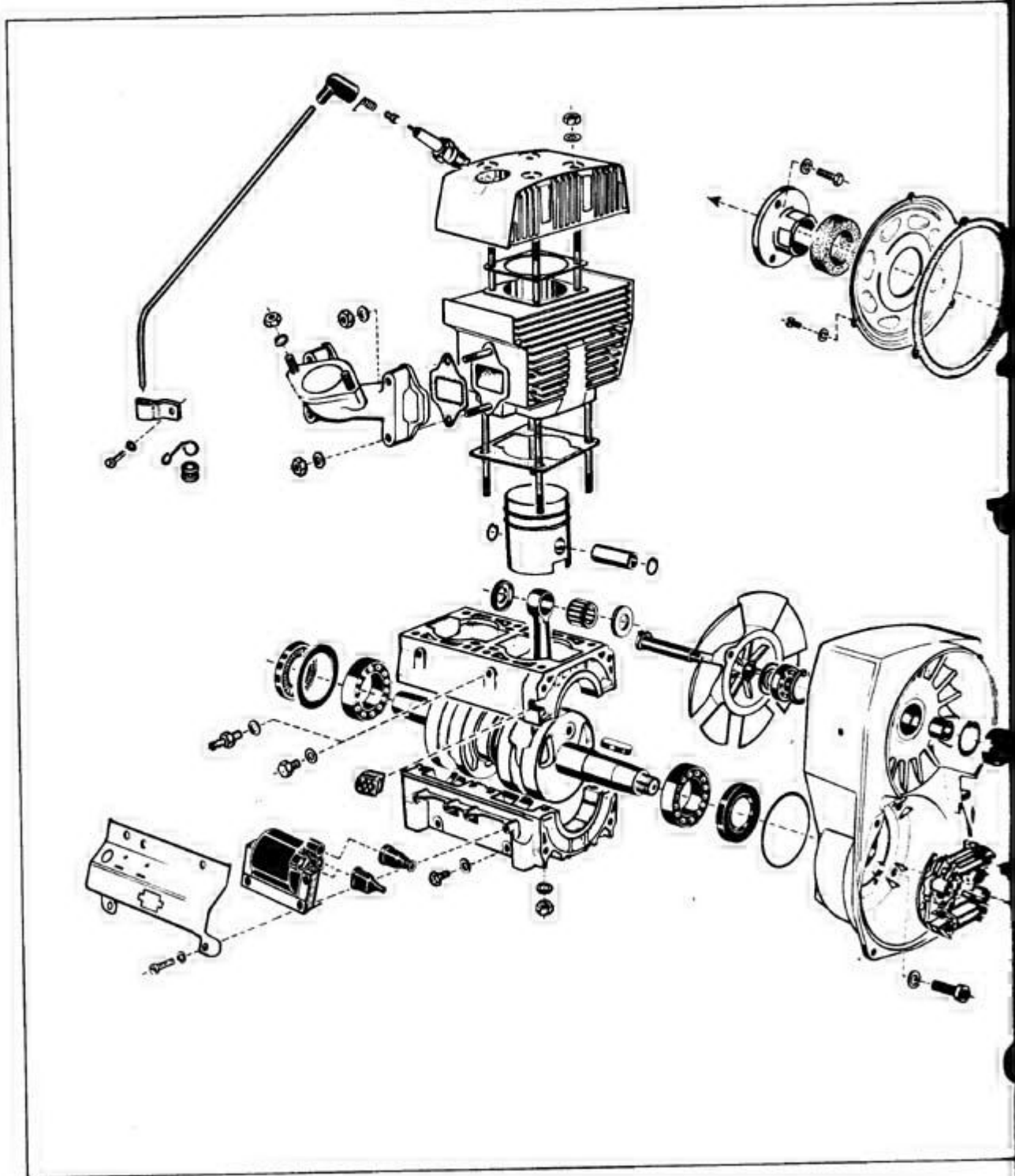

Electric Starter Wiring Diagrams

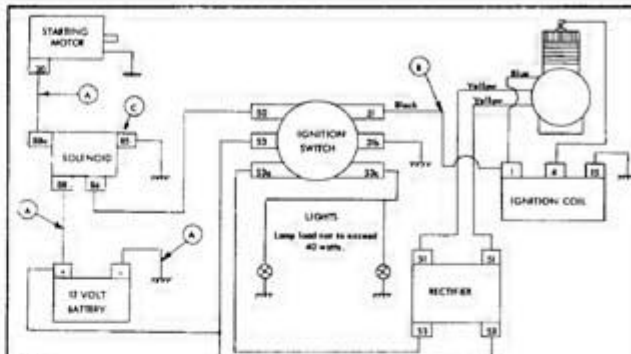
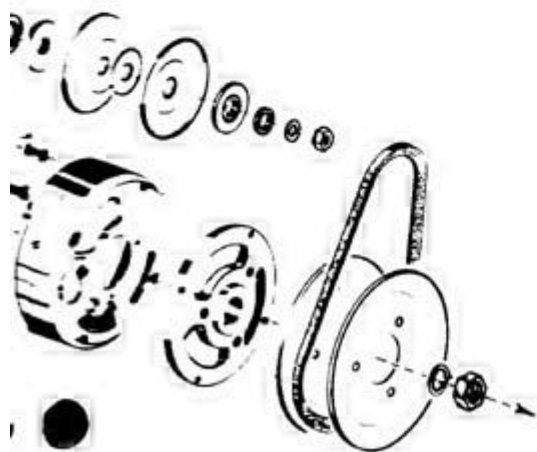
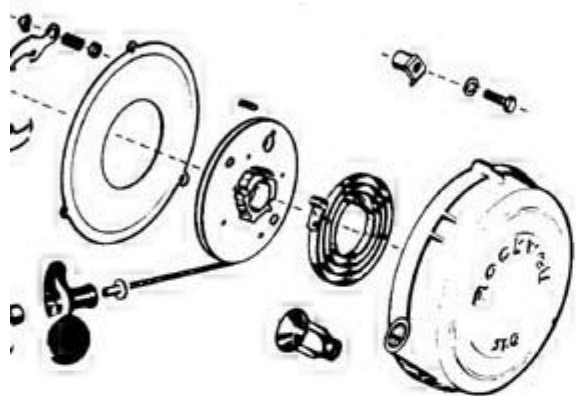

- A 12 volt battery cable. All others 14 G.
- B On some models, terminal 31 on switch is wired through overvoltage breaker points.
- C Terminal 32 used on rubber-mounted solenoids only.

ELECTRIC START
WIRING DIAGRAM
L 197
L 227
L 230

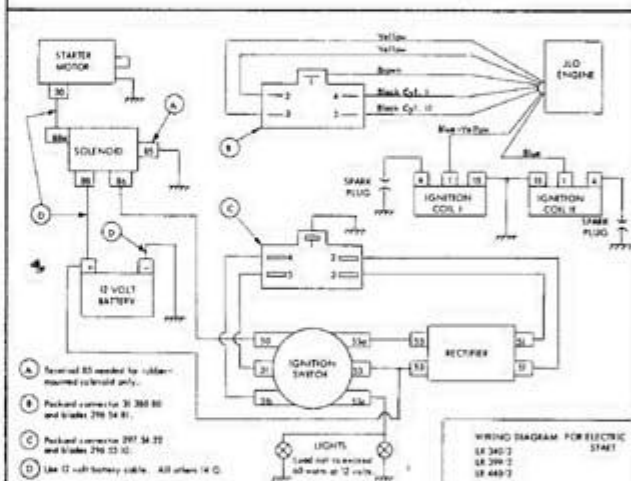

- A Terminal 32 needed for rubber-mounted solenoid only.
- B Packard connector 31 380 80 and blades 210 54 81.
- C Packard connector 207 54 22 and blades 210 52 10.
- D Use 12 volt battery cable. All others 14 G.

WIRING DIAGRAM FOR ELECTRIC
START
L 340-2
L 339-2
L 449-2

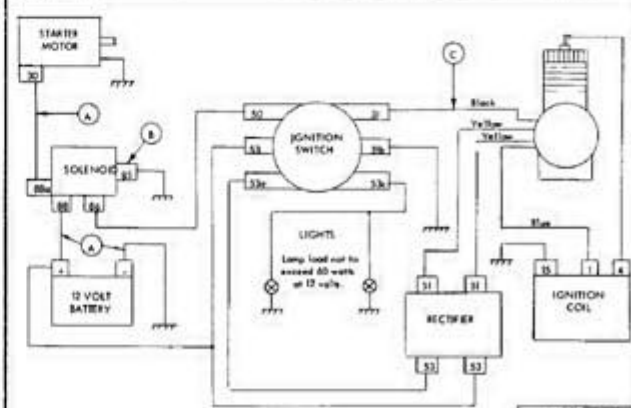

- A Use 12 volt battery cable. All others 14 G.
- B Terminal 32 used on rubber-mounted solenoids only.
- C In earlier models, this wire connects terminal 31 to terminal 1 on ignition coil.

ELECTRIC START
WIRING DIAGRAM
L 295
L 340
L 345

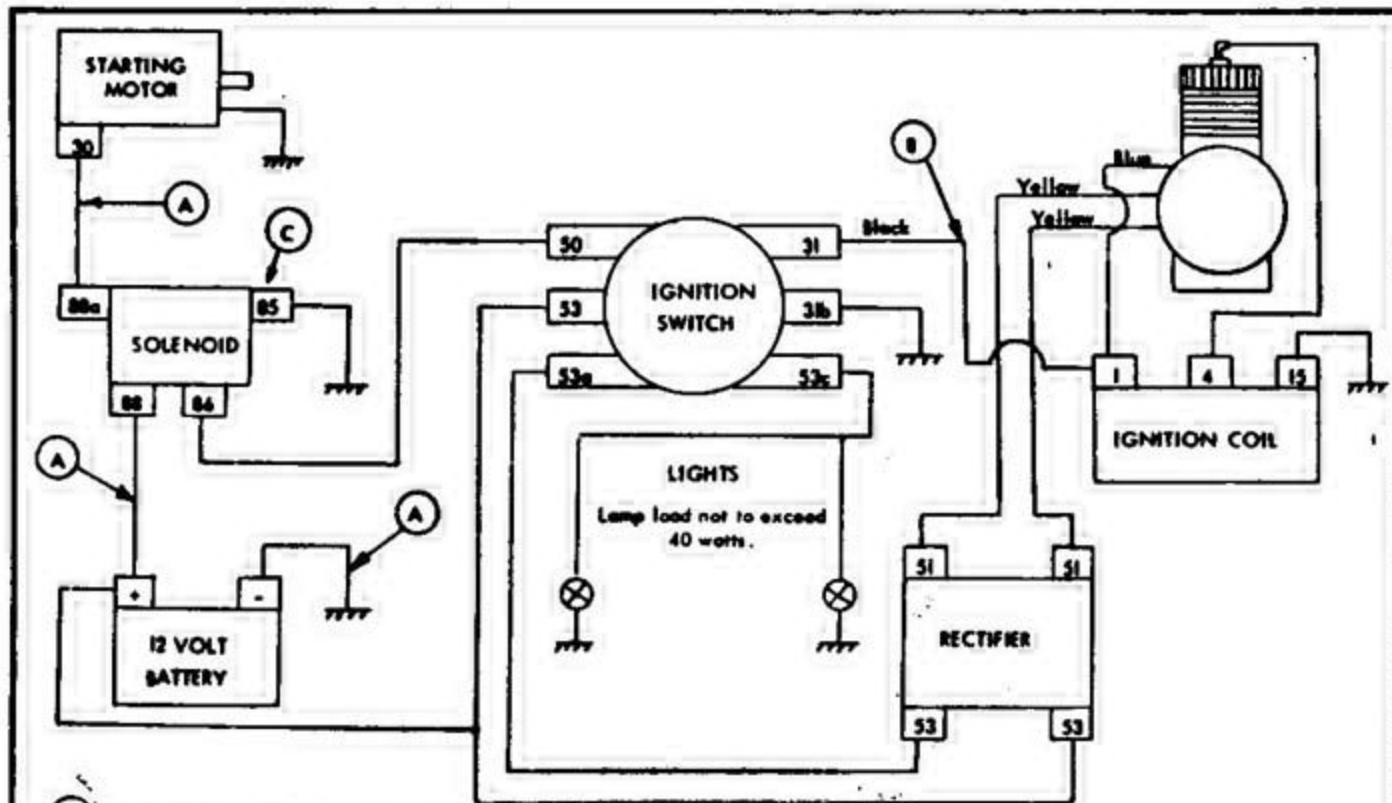

(A) 12 volt battery cable. All others 14 G.

(B) On some models, terminal 31 on switch is wired through crankcase to breaker points.

(C) Terminal 85 used on rubber-mounted solenoids only.

**ELECTRIC START
WIRING DIAGRAM**
L 197
L 227
L 230

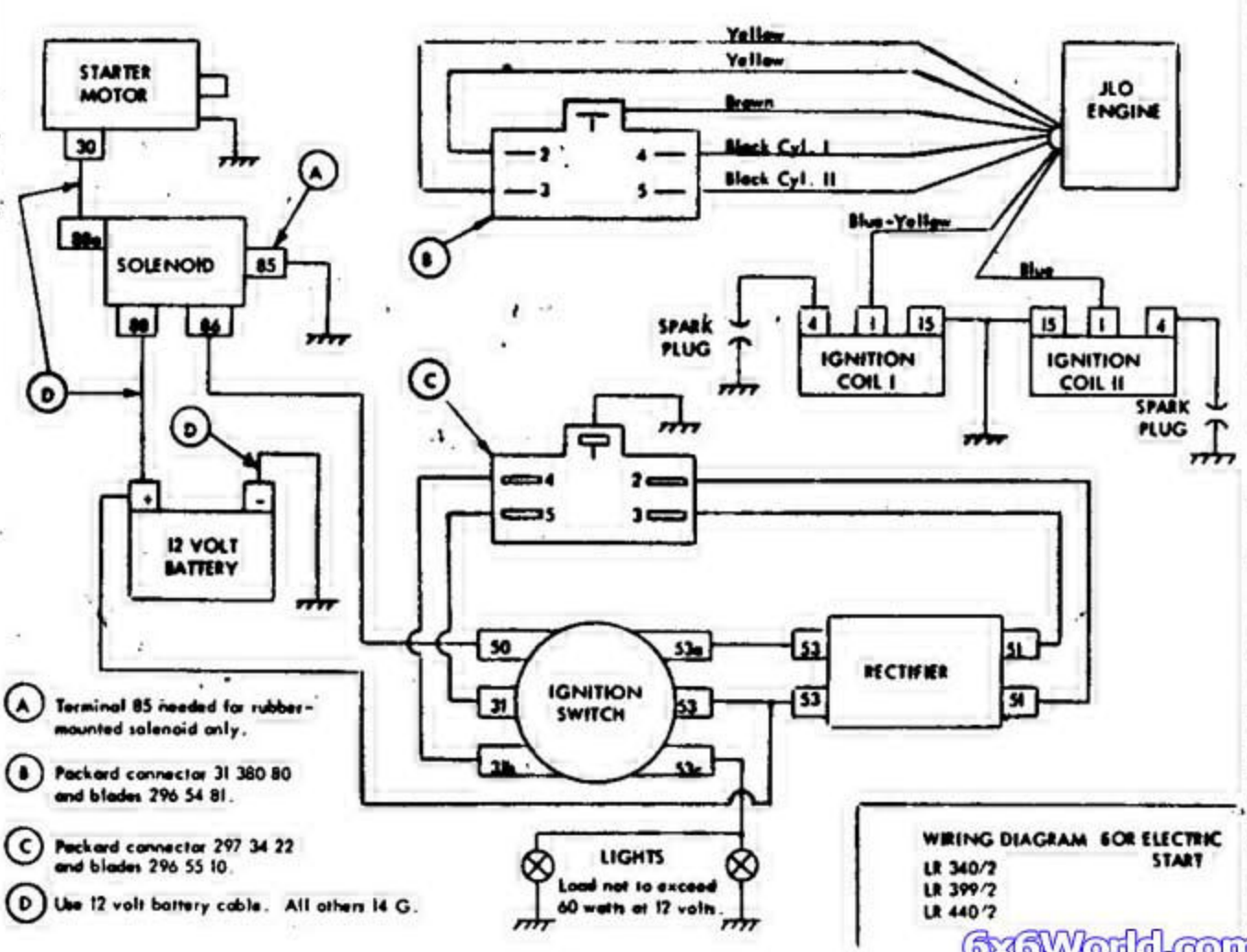

- (A) Terminal 85 needed for rubber-mounted solenoid only.
- (B) Peckard connector 31 380 80 and blades 296 54 81.
- (C) Peckard connector 297 34 22 and blades 296 55 10.
- (D) Use 12 volt battery cable. All others 14 G.

WIRING DIAGRAM FOR ELECTRIC START
 LR 340/2
 LR 399/2
 LR 440/2

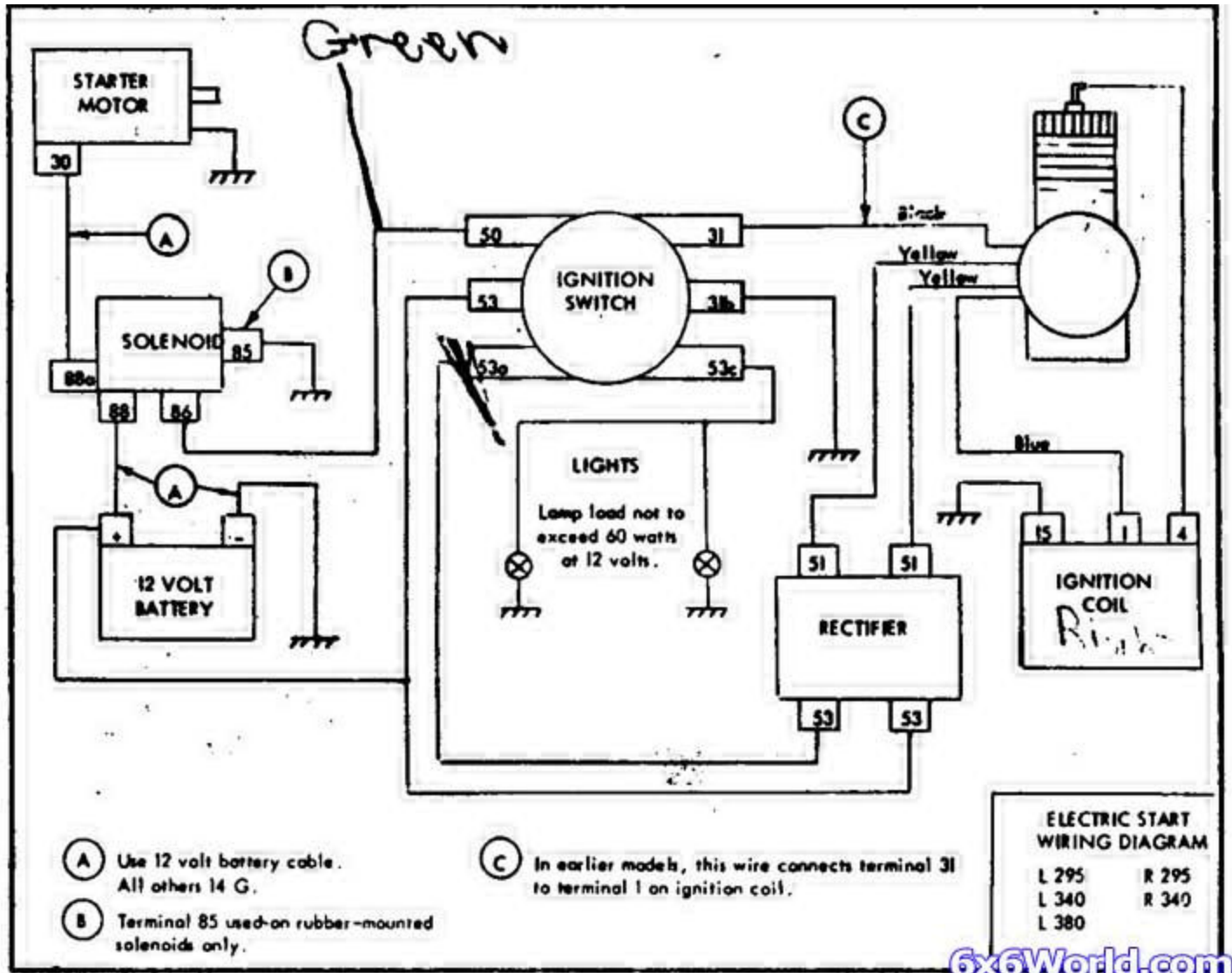



JLO Twin Cylinder Engines

Disassembly and Assembly Procedure - Model LB-600/2 (2F-600-1) Opposed Twin Cylinder Engine

Disassembly

A. Recoil Starter; Rope Pulley

1. Models with Recoil Starter: remove four slotted screws holding starter housing to fan cover; slip-off recoil unit, complete. Remove carrier assembly, emergency pulley and dust seal. (For detailed service instructions, see L-295 recoil starter instructions).
2. Models with Rope Pulley: remove the three bolts holding rope pulley to flywheel. Take off protective screen by removing four bolts on fan cover housing.

B. Fan Case Cover (Front)

Take out six bolts holding fan case cover to rear casting; remove cover.

C. Ignition Coils

Remove ignition coils.

D. Air Shrouds

Remove carburetor adapters and exhaust connections from each cylinder; take off air shrouds.

E. Flywheel Magneto

Make sure that spark plug is tight. Working against engine compression, remove crankshaft nut with 27 mm. socket wrench by striking wrench a few sharp blows with a rubber or plastic hammer. Pull the flywheel with a special flywheel puller. Note that the threaded portion of the puller must be firmly engaged with that of the flywheel hub. Turn the puller bolt until it touches the tip of crankshaft. With a 24 mm. socket wrench, turn the puller bolt clockwise and extract the flywheel. Note that crankshaft key may come loose and stick to flywheel magnets.

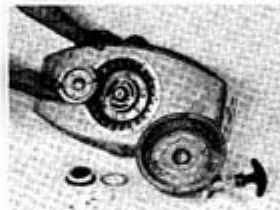

A

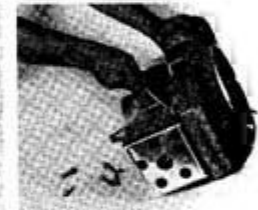

B1

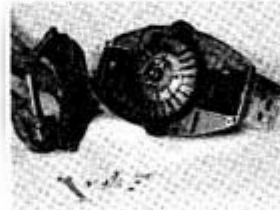

B2

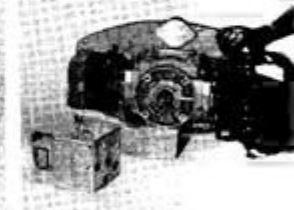

D1

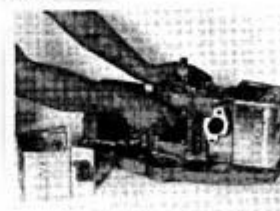

D2

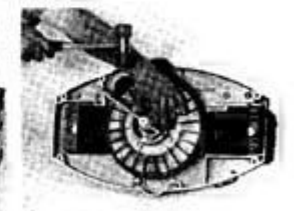

E1

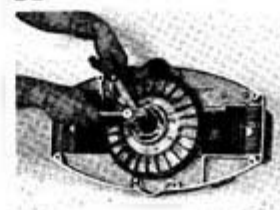

E2

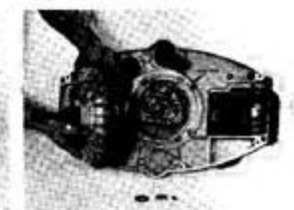

E3

F. Fan Case Cover (Rear)

With 13 mm. socket wrench, remove four fan case nuts, and take off washers. Pull off rear fan case cover.

G. Armature Plate

Remove the three slotted-head screws holding armature plate in place. Disconnect wire terminals from external coil. Lift out armature plate. Important: before pulling the armature plate make an alignment mark on it and the crankcase to facilitate later ignition timing.

H. Cylinder Heads

No. 1 Cylinder: 1) remove five cylinder head nuts (use 13 mm. socket); 2) lift off cylinder head; 3) remove cylinder head gasket; 4) scratch-mark corresponding cylinder and head to assure proper reassembly. Repeat procedure for cylinder No. 2.

I. Cylinders

No. 1 cylinder: 1) remove four cylinder base nuts; 2) gently lift cylinder until it clears the skirt; 3) remove cylinder base gasket. Repeat procedure for cylinder No. 2.

J. Pistons

No. 1 Piston: 1) with needle nose pliers remove circlips—one on each side of wrist pin; 2) gently drive out the wrist pin and lift off piston; 3) remove check plates and upper rod bearing; 4) scratch-mark piston and corresponding cylinder for proper reassembly. Repeat procedure for No. 2 piston.

K. Crankcase; Oil Seals

Crankcase: 1) remove crankcase cover nuts; 2) Separate crankcase (Note: If crankcase halves separate without application of heat it is an indication that crankcase castings are worn out and should be replaced). 3) Turn crankcase on its side and slide hollow protective pipe over the crankshaft to protect oil seal (pipe should have I.D. slightly larger than oil seal). 4) apply heat around bearing seat (do not overheat); 5) use protective gloves and lift off casting. Repeat procedure for other half of crankcase. (Important: do not cut oil seals on sharp edges of crankshaft keyway).

L. Crankshaft; Crankshaft Bearings

Place crankshaft on work surface and use special puller to remove bearings: 1) slide puller over crankshaft and align bolt with crankshaft end; 2) slip half shells around the bearing and engage them with puller grooves; 3) slide retaining ring over half shells to keep them on bearing; 4) use two open end wrenches and turn puller bolt with one wrench while holding puller body with the other; 5) keep turning bolt clockwise until bearing comes to the end of crankshaft.

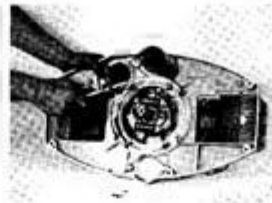

F1



F2



G



H



I



J

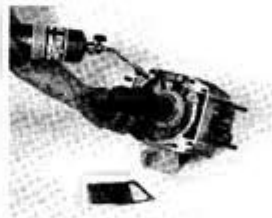

K1



K2

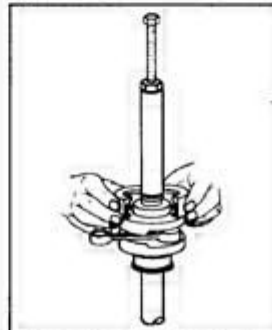

L1

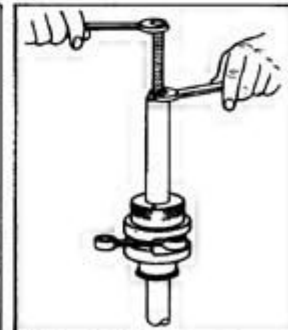

L2



JLO Twin Cylinder Engines

Disassembly and Assembly Procedure - Model LB-600/2 (2F-600-1) Opposed Twin Cylinder Engine

Assembly

1. Crankshaft

Heat crankshaft bearings in oil preheated to 215°F. After reaching temperature, quickly slip bearing over end of crankshaft; it should fall freely on the counterweight. Using a hollow pipe with a diameter approximately that of the inner bearing race, hit pipe with a rubber hammer and seat the bearing on the shaft. The bearing should now rest securely and turn freely. Repeat procedure for bearing on other end of crankshaft.

2. Crankcase

A) Check both halves of crankcase and clean, carefully removing any left-over gasket material or burrs; B) with the P.T.O. side of the crankcase facing up, heat bearing seat area while protecting oil seal with a hollow pipe (see instructions K-3 and K-4; *disassembly*); C) guide crankshaft through the oil seal until the bearing fits easily into its seat; D) let casting cool, then install crankcase gasket; E) to assemble the other half of crankcase, repeat items 2, 3 and 4, as applicable; F) check alignment of crankcase halves with a straight edge and G) firmly tighten nuts crosswise.

3. Piston and Cylinder

No. 1 Piston; No. 1 Cylinder: A) Clean carbon deposits from piston; B) check to see that rings move freely in their grooves; C) mate piston with corresponding cylinder; D) install piston with arrow pointing toward the exhaust port; E) insert needle bearings into the connecting rod and put daub of grease on rod so that check plates installed later will adhere to it. Gently guide the piston over the connecting rod and insert the wrist pin. Snap circlips into each side of the piston using needle-nose pliers. Install cylinder-base gasket. Place a V-shaped wood block under the piston, resting it on the crankcase. After lining up the rings with the locating pins on the piston, compress them with a ring compressor. Rest piston on wood block and carefully slide cylinder over the piston until the rings disappear into the cylinder. Remove ring compressor and wood block. Install cylinder base nuts and torque-down crosswise (28/32 ft.lbs.).

4. Cylinder Head

Install cylinder head gasket with the wide side of the metal ring facing up, then the cylinder head. Install flat washers, lock washers and nuts. Tighten (16/18 ft.lbs.)

5. Armature Plate

Before installing the armature plate inspect it for loose connections, pinched wires, worn out contact breakers and defective condenser. Note: the condenser is pressed into the plate and can be removed and replaced with a special Bosch tool. Install rubber grommet and feed wires through it. Place armature in the original position marked in disassembly (instruction G) and fasten it using the three slotted screws. Attach the terminal clips to the wires and connect to the external coil.

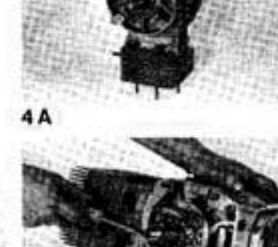
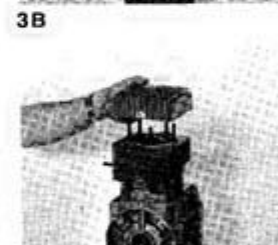
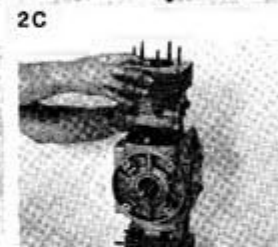
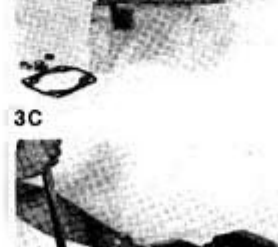
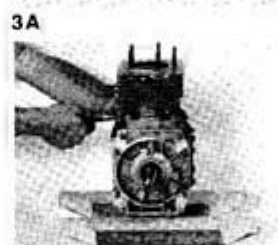
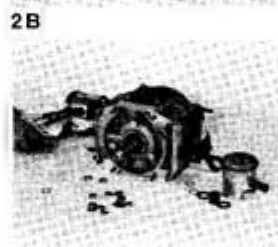
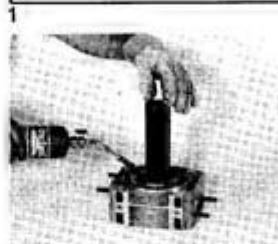
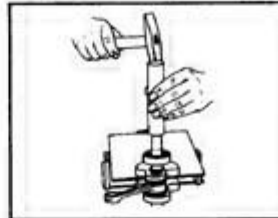

6. Fan Case Cover (Rear)

Install fan case cover, nuts and washers and tighten (6-18 ft.lbs.).

7. Air Shrouds

Install air shrouds over each cylinder making sure to include 2 gaskets on each side of each cylinder head; that is, 2 exhaust gaskets (one on each side of shroud) and 2 intake gaskets (one on each side of shroud). Attach adapter block and exhaust flange and tighten with slotted screws and nuts, respectively.

8. Ignition Coils

Attach both ignition coils using socket cap screws provided (be sure to install coil spacers first). Connect all wires to their respective terminals.

9. Spark Plugs

Install and tighten spark plugs.

10. Flywheel

Align flywheel with keyway; insert and tap into position. Tighten flywheel nut (79/87 ft.lbs.). (For timing, refer to Timing Procedure.)

11. Fan Case Cover (Front)

Install front fan case cover and tighten down with hexhead screws provided.

12. Recoil Starter; Rope Pulley

1. *Models with Recoil Starter:* Install carrier assembly, emergency pulley, dust seal and tighten. Replace recoil starter assembly.

2. *Models with Rope Pulley:* Install protective screen to fan housing and fasten rope pulley to flywheel using bolts provided.



6



7

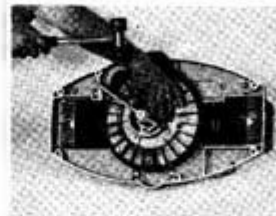

10



11

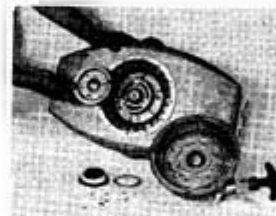

12

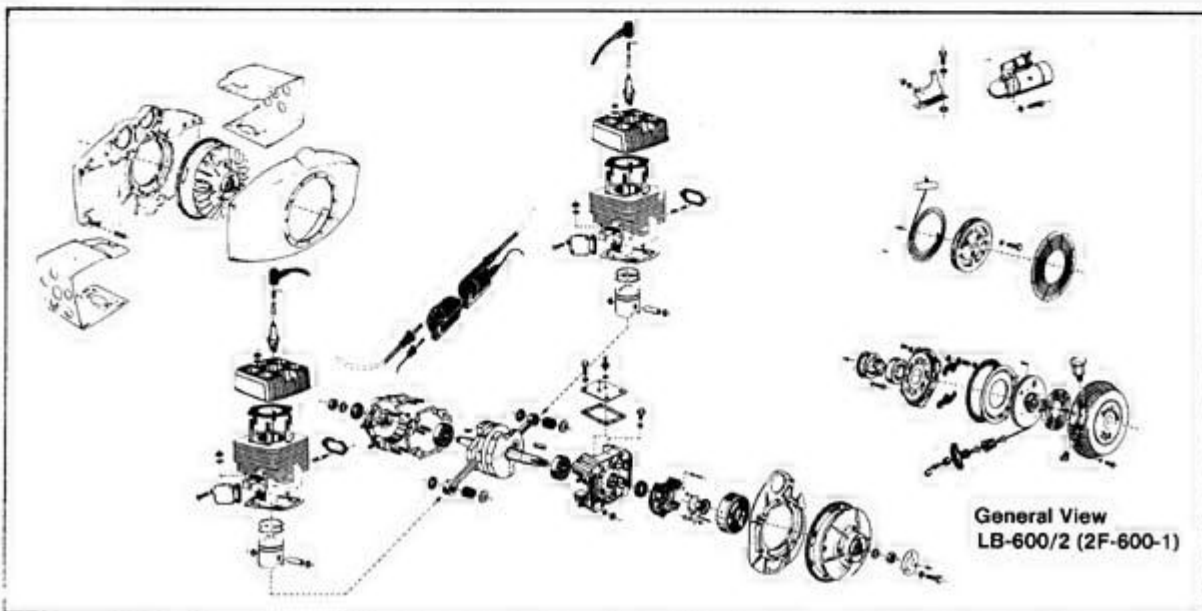

JLO Twin Cylinder Engines

Timing Procedure For LB-600/2 (2F-600-1) Opposed Twin Cylinder Engine

Remove recoil starter and carrier, or rope pulley and proceed as follows:

- A.** Attach the dial indicator to either cylinder.
- B.** Set breaker point gap. *Note:* if flywheel is removed, use an old cam and rotate until the points are at their largest opening. Check gap and adjust to specifications as necessary.
- C.** Turn the flywheel clockwise to TDC (top dead center). If the contact breakers are not accessible at this instant, continue clockwise rotation until the breaker points are visible. Use a clean and greaseless feeler gauge to check the gap.
- D.** Advance the centrifugal weight. Hold in place using locking pin, (a tool specially designed for this purpose).
- E.** Attach one lead of the ignition timing light to the black "kill" wire, the other to ground (engine casting).
- F.** Bring piston to TDC and adjust dial to zero.
- G.** Turn flywheel counterclockwise (away from Top Dead Center), closely observing dial indicator and timing light. When the piston reaches the timing point the light will dim, indicating the opening of the points. Check the dial indicator and, if timing does not agree with specifications, do not change the breaker point gap but, instead, adjust by loosening the armature plate and rotating the complete assembly. Clockwise rotation will retard the ignition, counterclockwise will advance the ignition. Correct breaker gap will insure maximum ignition output.

Note: This is a simultaneously firing engine; that is, when one cylinder is in time, the other is also in time, however, the second cylinder must still be checked.

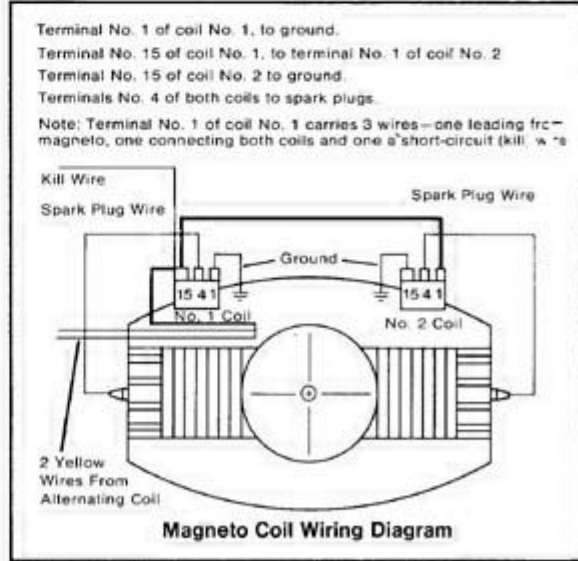
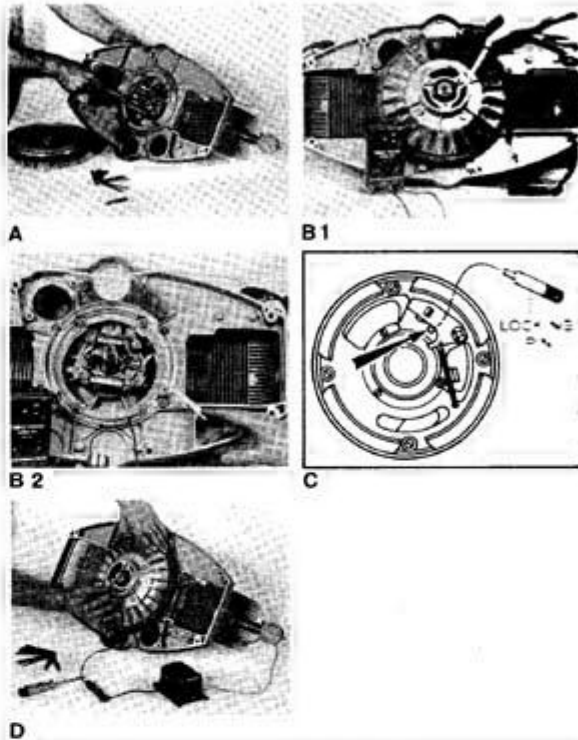



JLO Engines

General Trouble Shooting . . .

A thorough check should be made before any overhaul procedures are taken. Following this practice will help eliminate unnecessary repairs.

1. Engine does not start or starts with difficulty

POSSIBLE CAUSE	REMEDY
No fuel in tank	Fill tank with clean, fresh fuel and oil mixture.
Obstructed fuel line or filter	Clean fuel filter and line. If necessary remove and clean carburetor.
Fuel tank cap vent hole obstructed	Open vent hole.
Water in fuel	Drain tank. Clean carburetor and fuel lines. Dry spark plug electrodes. Fill tank with clean, fresh fuel and oil mixture.
Engine over-choked ("flooded")	Turn engine over several times with choke "IN". Refer to symptoms No. 8 through 15.
Improper carburetor adjustment	Adjust carburetor.
Loose or defective magneto and/or wiring	Check magneto wiring for shorts or grounds. Check timing, point gap, and adjust or repair as necessary. See also "Trouble-Shooting Ignition System".
Spark plug fouled	Clean and regap spark plug.
Spark plug porcelain cracked	Replace spark plug.
Poor compression	Check compression and make necessary repairs. See "Checking Engine Compression".

2. Engine Knocks

POSSIBLE CAUSE	REMEDY
Carbon in combustion chamber	Remove cylinder head and clean carbon from head and piston.
Loose or worn connecting rod (or rod bearing)	Replace crankshaft assembly.
Loose flywheel	Check flywheel key and keyway; replace parts if necessary.
Worn cylinder	Replace cylinder.
Incorrect magneto timing	Time ignition. See "Trouble-Shooting Ignition System".

3. Engine Misses Under Load

POSSIBLE CAUSE	REMEDY
Spark plug fouled or improper gap	Clean and regap spark plug.
Spark plug porcelain cracked	Replace spark plug.
Loose or defective magneto and/or wiring	Check timing, point gap and wiring for defects. See "Trouble-Shooting Ignition System".
Improper carburetor adjustment	Adjust carburetor. See symptoms No. 8 through 15.



JLO Engines

General Trouble Shooting . . .

4. Engine Lacks Power

POSSIBLE CAUSE	REMEDY
Choke practically closed	Open choke.
Improper carburetor adjustment	Adjust carburetor. See symptoms No. 8 through 15.
Improperly timed	Time engine. See "Trouble-Shooting Ignition System".
Loss of compression	Check compression and make necessary repairs. See "Checking Engine Compression".
Carburetor dirty or damaged	Clean and repair carburetor.

5. Engine Overheats

POSSIBLE CAUSE	REMEDY
Engine improperly timed	Time engine. See "Trouble-Shooting Ignition System".
Carburetor improperly adjusted (lean)	Adjust carburetor.
Cooling fins clogged	Clean cooling fins.
Excessive load on engine	Check operation of associated equipment. Reduce excessive load.
Carbon in combustion chamber	Clean carbon from head and piston.
Improper gasoline-to-oil mixture	See "Engine Specifications" for mixture ratio.

6. Engine Surges Or Runs Unevenly

POSSIBLE CAUSE	REMEDY
Fuel tank cap vent hole clogged	Open vent hole.
Carburetor throttle linkage or throttle shaft and/or butterfly binding or sticking	Clean, lubricate or adjust linkage and deburr throttle shaft or butterfly.
Carburetor not properly adjusted	Adjust carburetor. See symptoms No. 8 through 15.

7. Engine Vibrates Excessively

POSSIBLE CAUSE	REMEDY
Engine not securely mounted	Tighten mounting bolts.
Bent crankshaft	Replace crankshaft.
Drive or drive pulleys defective	See "Operational Check of Drive Pulleys".



8. Carburetor Floods

POSSIBLE CAUSE	REMEDY
Damaged or worn inlet needle or seat (or dirt in seat assembly). Inlet seat gasket damaged.	Service carburetor as recommended.
Diaphragm damaged or incorrectly installed	Service carburetor.
Inlet control lever stuck, incorrectly adjusted, tight on fulcrum pin, fulcrum pin loose, or spring not seating on lever dimple.	Service carburetor.
Fuel tank pressure build-up	Check and open tank vent.
Damaged or faulty choke stop (allowing choke to close)	Replace choke shaft assembly if necessary.

9. Carburetor Runs Rich With Mixture Screw Shut Off

POSSIBLE CAUSE	REMEDY
Ruptured pump diaphragm	Replace diaphragm.
Welch plugs not sealing	Reseat or replace Welch plugs.
Carburetor floods	See symptom No. 8. Correct as required.

10. Carburetor Runs Lean In All Speed Ranges

POSSIBLE CAUSE	REMEDY
Inlet filter screen plugged or dirty	Clean or replace screen.
Inlet control lever incorrectly adjusted	Readjust lever per carburetor servicing instructions.
Diaphragm cover plates loose	Tighten screws.
Air leak into the metering system	Service carburetor and make sure all channel plugs, plug screws, and Welch plugs are tightly sealed.
Inlet tension spring stretched or damaged	Replace spring.
Fuel pump not operating properly	Service carburetor as recommended.
Carburetor loose on mounting, or leaking gasket	Tighten mounting screws and/or replace gasket as necessary.
Air leak in fuel lines	Correct as required.
Fuel line plugged	Clean all fuel lines.
Fuel tank vent plugged or not operating	Repair as necessary.
Pump pulse channel plugged or not aligned to engine	Clean or correct all alignment.
Pump valve flippers damaged or bent off ports	Service carburetor and replace diaphragm.
Clogged fuel channels	Clean (and service) carburetor.



JLO Engines

General Trouble Shooting. . .

11. Engine Will Not Accelerate, Or Lean Acceleration

POSSIBLE CAUSE	REMEDY
Idle mixture set too lean	Adjust idle mixture.
Fuel channels plugged	Clean (and service) carburetor.
Power valve ball check stuck closed	Remove Welch plug and steel ball, then blow channel clean with air.
Low inlet lever setting	Readjust lever per servicing instructions.
Diaphragm cover plate loose or leaking diaphragm gasket	Tighten cover plate screws and/or replace gasket as necessary.
Carburetor loose on mounting or leaking gasket	Tighten mounting screws and/or replace gasket as necessary.

12. Engine Runs Lean At Idle Speed

POSSIBLE CAUSE	REMEDY
Idle mixture set too lean	Adjust idle mixture.
Dirt in fuel channels	Clean and Service carburetor.
Welch plugs not sealing properly	Reseat or replace Welch plugs.
Inlet control lever incorrectly adjusted	Readjust per instructions.
Main fuel check valve not sealing	Service carburetor and repair as necessary.

13. Engine Runs Rich At Idle Speed

POSSIBLE CAUSE	REMEDY
Carburetor flooding	See symptom No. 8. Correct as necessary.
Throttle shutter cocked in throttle bore	Adjust shutter correctly.
Idle air bleed plugged	Clean and service carburetor.
Idle adjustment screw damaged	Replace adjustment screw.
Idle adjustment hole damaged or casting cracked near the adjustment point	Replace carburetor.

14. Engine Runs Lean At Operating And/Or High Speeds

POSSIBLE CAUSE	REMEDY
Mixture adjustment set too lean	Adjust mixture.
Inlet control lever incorrectly adjusted	Readjust per instructions.
Main fuel check valve damaged or not sealing	Service carburetor per instructions.



General Trouble Shooting, Trouble Shooting the Ignition System

14. Engine Runs Lean At Operating And/Or High Speeds (Con't)

POSSIBLE CAUSE	REMEDY
Dirt in nozzle system or supply channels. Channel plugs not sealing.	Clean and service carburetor.
Power valve ball stuck closed. (Applies if engine runs lean at intermediate speeds.)	Service carburetor, remove Welch plug and steel ball, blow out channels and replace parts as necessary.
Adjustment packing damaged. (Applies to symptom at high speed.)	Replace packing.

15. Engine Runs Rich At Operating And/Or High Speeds

POSSIBLE CAUSE	REMEDY
Mixture adjustment set too rich	Adjust mixture.
Carburetor flooding	See symptom No. 8.
Inlet control lever incorrectly adjusted	Readjust per instructions.
Power valve ball check not seating (Applies if symptom is at high speed.)	Remove Welch plug and ball, then blow channel clean. Replace parts as required.
Main fuel check valve Welch plug not sealing. (Applies if symptom is at intermediate speeds.)	Reseat or replace Welch plug.
Choke valve partially closed. (Applies if symptom is at intermediate speeds.)	Check choke friction springs and ball. Repair carburetor as necessary.

Trouble Shooting the Ignition System

To thoroughly check the ignition system for possible malfunctions, follow the systematic procedures under this heading.

1. Visually check the spark plug for its condition, then clean and test it using a suitable cleaning and testing unit. Measure the electrode gap and readjust as necessary. If spark plug proves to be defective, replace it with a new one of the correct heat value.

2. Check all visible wiring for possibility of shorting and make sure all connections are tight.

3. Check breaker point gap and ignition timing per instructions under "Ignition Timing".

4. Check condenser and coil armatures for defective operation using suitable testing equipment. Follow the procedures recommended by the test equipment manufacturers.



JLO Engines

Trouble Shooting The Starter

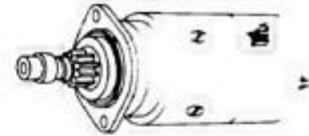

Causes of troubles are often not necessarily in the starter itself nor in the battery, switches, cables, cable connections and defective electrical connections of vehicle grounding

parts, but also in the ignition system and the fuel line. The following directions on trouble-shooting are limited to the starting system.

A. When Starting, The Starter Shaft Does Not Turn Or Turns Too Slowly.

POSSIBLE CAUSE	REMEDY
Battery discharged	Charge the battery.
Battery defective	Have the battery checked in the workshop.
Loose or oxidized battery terminals; bad ground connection	Tighten terminals; clean poles and terminals and grease with anti-acid grease.
Starter terminals or brushes shorted to ground	Remove the ground shorts.
Starter carbon brushes are not sitting on the commutator; clamped in their guides; worn, broken, oiled or dirty	Check carbon brushes, clean or replace. Clean guides in brush holder as required.
Starting switch damaged (loose parts so that the switch cannot make contact; burnt).	Replace starting switch.
Starter solenoid damaged	Replace solenoid.
Voltage drop across cables too large; damaged cables, loose cable connections	Check starter cables and their connections.

B. Armature Turns, But Pinion Does Not Engage

POSSIBLE CAUSE	REMEDY
Pinion dirty	Clean pinion.
Pinion or flywheel teeth chipped; burr formation	File off burrs.

C. When Switching On, The Starter Armature Turns Until The Pinion Engages; Then It Stops.

POSSIBLE CAUSE	REMEDY
Battery is not sufficiently charged	Charge the battery.
Carbon brush pressure too low	Check the carbon brushes. Clean or replace.
Starter solenoid defective	Replace solenoid.
Voltage drop across the cables too large	Check cables and connections.
Overrunning clutch slipping	Repair or replace clutch.

D. Starter Continues To Run After The Switch Is Released

POSSIBLE CAUSE	REMEDY
Starter switch does not switch off or the solenoid is stuck	Immediately disconnect the starter cable at the battery or starter; have switch repaired or replace.

E. Pinion Does Not Disengage When The Engine Starts.

POSSIBLE CAUSE	REMEDY
Pinion or flywheel teeth very dirty or damaged, return spring weak or broken	Carefully clean or file off the burrs on flywheel teeth and pinion (push the vehicle back and forth while in gear); replace return spring.



A. IDLE SYSTEM

1. Idle Operation Too Lean

POSSIBLE CAUSE	REMEDY
Adjustment set too lean	Readjust.
Dirt in idle fuel channels	Blow out with compressed air.
Channel plugs missing or not tightly sealed	Re-seat or replace channel plugs.
Main fuel check valve not sealing	Blow out with compressed air or replace.
Inlet control lever set too far away from diaphragm	Re-set control lever flush with metering chamber wall.

2. Idle Operation Too Rich

POSSIBLE CAUSE	REMEDY
Carburetor flooding	See item E.
Idle adjustment screw point damaged	Replace the adjustment screw.
Idle air bleed plugged	Blow out with compressed air.
Idle adjustment hole damaged, forced, oversize or casting cracked near the adjustment point	Replace carburetor.

B. INTERMEDIATE SYSTEM

1. Lean Operation At Intermediate Speeds

POSSIBLE CAUSE	REMEDY
Adjustment set too lean	Readjust.
Dirt in intermediate fuel ports or supply channels	Blow out with compressed air.
Channel plugs missing or not tightly sealed	Re-seat or replace channel plugs.
Main fuel check valve not sealing	Blow out with compressed air or replace.
Power valve ball stuck closed	Remove Welch plug and steel ball and blow out channel with compressed air.
Inlet control lever incorrectly set	Readjust inlet control lever.

2. Rich Operation At Intermediate Speeds

POSSIBLE CAUSE	REMEDY
Adjustment set too rich	Readjust.
Carburetor flooding	See item E.
Main fuel check valve Welch plug not tightly sealed	Re-seat or replace.
Choke valve partially closed	See that choke friction spring and ball are correctly assembled.
Inlet control lever incorrectly set	Readjust inlet control lever flush with metering chamber wall.

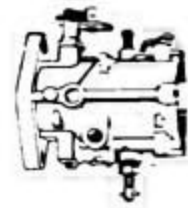

C. MAIN NOZZLE SYSTEM

1. Lean Operation At High Speeds

POSSIBLE CAUSE	REMEDY
Adjustment set too lean	Readjust.
Dirt in nozzle system	Blow out channels with compressed air.
Adjustment packing damage	Replace O-ring.
Main fuel check valve damaged	Replace.
Main fuel check valve not seated correctly in body casting	Re-seat the assembly flush with nozzle well surface.
Inlet control lever incorrectly set	Readjust inlet control lever flush with metering chamber wall.

2. Rich Operation At High Speeds

POSSIBLE CAUSE	REMEDY
Adjustment set too rich	Readjust.
Carburetor flooding	See item E below.
Power valve ball check not seating	Remove Welch plug and steel ball and blow out channel with compressed air.
Inlet control lever incorrectly set	Readjust inlet control lever flush with metering chamber wall.

D. ACCELERATING PUMP SYSTEM

1. Lean Acceleration

POSSIBLE CAUSE	REMEDY
Incorrect adjustment	Readjust.
Dirt in acceleration fuel channels	Blow out all channels in the metering diaphragm cover and the accelerating pump outlet in the carburetor body.
Accelerating pump assembly damaged or worn	Replace this assembly.
Diaphragm cover plug screw loose or missing	Tighten or replace.
Power valve ball check stuck closed	Remove Welch plug and steel ball and blow channel clear with compressed air.

E. CARBURETOR FLOODING

POSSIBLE CAUSE	REMEDY
Dirt in inlet needle and seat assembly	Remove and clean or replace.
Inlet seat gasket missing or damaged	Replace gasket.
Inlet control lever incorrectly adjusted	Readjust lever flush with metering chamber wall.
Diaphragm incorrectly installed	Replace or correct installation.



JLO Engines

Trouble Shooting the Carburetor -Models HR and HD

E. CARBURETOR FLOODING (Con't)

POSSIBLE CAUSE	REMEDY
Inlet control lever pin loose or not correctly installed	Tighten retaining screw and correct installation.
Inlet control lever tight on fulcrum pin	Replace damaged part or clean dirt from these parts.
Inlet needle or seat damaged or worn	Replace the assembly.

NOTE: If flooding persists, clean the fuel tank and fuel lines.

F. GENERAL OPERATION

1. Lean Operation In All Speed Ranges

POSSIBLE CAUSE	REMEDY
Filter screens plugged or dirty	Clean or replace.
Inlet control lever incorrectly adjusted	Readjust lever flush with wall of metering chamber.
Diaphragm cover plates loose	Tighten screws.
Air leak into the metering system	All channel plugs, plug screws and lead plugs to be tightly sealed.
Inlet tension spring stretched or damaged	Replace spring.
Fuel pump not operating	Clean fuel pump and replace worn parts or check assembly to be certain that gaskets and diaphragms are correctly installed.
Carburetor loose on manifold	Tighten in place.
Air leak in fuel lines	Replace fuel line.
Fuel line plugged	Clean fuel line.
Low fuel supply	Fill fuel tank.
Pump pulse channel plugged or not aligned to engine	Clean or correct alignment.
Fuel tank vent not operating	Repair vent.

2. Rich Operation In All Speed Ranges

POSSIBLE CAUSE	REMEDY
Ruptured pump diaphragm	Replace diaphragm.
Carburetor flooding	See item E (page 11).
Lead plugs not sealing	Re-seat or replace.
Inlet control lever incorrectly set	Readjust lever flush with wall of metering chamber.
Plugged air filter	Clean or replace.

© 1994 JLO Engines Mfg. Co.



A. Carburetor Richness

POSSIBLE CAUSE	REMEDY
Diaphragm lever set too high	Set to specification shown in Ill. No. 6.
Dirt under inlet needle valve	Remove and clean.
Metering lever spring not seated on the dimple in the metering lever	Remove lever and install as per Ill. No. 6.
Fuel pump diaphragm leaking	Remove and replace with new diaphragm.
Dirt under the umbrella check valve	Blow through screen on the reverse side of plate.

B. Carburetor Leanness

POSSIBLE CAUSE	REMEDY
Dirt in idle fuel channels	Disassemble and clean carburetor.
Metering lever set too low	Set flush with bases on chamber floor (ILLUSTRATION NO. 6).
Leaky nozzle check valve diaphragm	Replace diaphragm.
Hole in metering diaphragm	Replace diaphragm.
Pulse line from crankcase to carburetor plugged	Clean.
Leaky manifold gaskets	Replace gaskets.
Leaky diaphragm check valve	Replace diaphragm check valve assembly.
Fuel pump diaphragm check valve worn	Replace fuel pump diaphragm.
Dirty fuel inlet screen	Remove bottom plate and clean.
Faulty fuel delivery system to carburetor	Check complete fuel delivery system from pick up in fuel tank to carburetor, fuel inlet for cracks, dirt, etc. Replace fuel line or pick up filter when necessary.

C. Needle Settings

The power and idle needles control the lubrication received by the engine. Adjustments should be done carefully. Start by turning the needles all the way in (do not force them). Set Power (high speed) needle one and one-quarter (1¼)

open and the Idle (low speed) needle one and one-quarter (1¼) turn open. This puts both slightly on the rich side and leaner adjustments can be made as needed. (Too lean an adjustment can cause improper lubrication).

Courtesy of Walbro Carburetors

JLO Engines

Service Items

Service Items

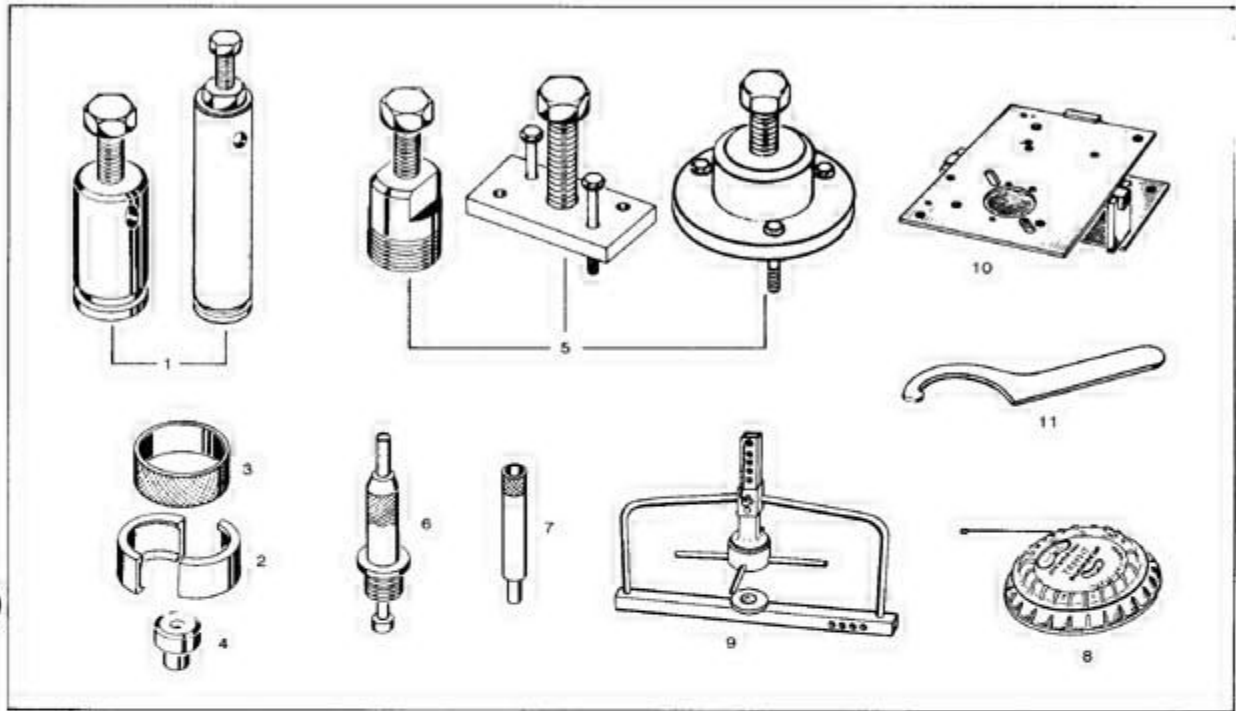

Single Cylinder

Twin Cylinder

ILLUS. NO.			L-99	L-227	L-230	L-295	L-297	L-300	L-340	LR-340/2 (2F-340-1)	LR-399/2 (2F-400-1)	LR-440/2 (2F-440-2)	LB-600/2 (2F-600-1)
10	Universal Assembly Jig	444.31-804-10	X	X	X	X	X	X	X	X	X	X	X
9	Recoil Starter Clamping Jig	444.31-863-10		X	X	X	X	X	X	X	X	X	X
1	Extractor (Crankshaft Bearing)	444.31-807-00	X	X	X	X	X	X	X	X	X	X	X
2	Half Shells (2)	444.31-067-00	X										
2	Half Shells (2)	444.31-072-00		X	X					X	X	X	
2	Half Shells (2)	444.31-073-00				X	X	X	X				X
2	Half Shells (2)	444.31-449-00	X										
4	*Pressure Piece	444.31-690-00				X	X	X	X	X	X	X	
3	Retaining Ring	444.31-071-00		X	X	X	X	X	X	X	X	X	X
3	Retaining Ring	444.31-065-00	X										
7	Guide Pin	444.31-666-00				X	X	X	X	X	X	X	X
11	Spanner Wrench	000.15-22-040	X										
5	Flywheel Extractor	444.31-873-00		X	X								
5	Flywheel Extractor	444.31-843-01								X	X	X	
5	Flywheel Extractor	444.31-814-10				X	X	X	X				X
5	Flywheel Extractor	444.31-881-00	X										
5	Timing Gauge	444.31-875-00	X	X	X	X	X	X	X				X
5	RPM Indicator	000.15-30-010	X	X	X	X	X	X	X	X	X	X	X

* Use bearing extractor to prevent damage to crankshaft internal threads.



JLO Engines

Gasket Sets, Spark Plug Recommendations

Gasket Sets

Model	Description	Part No.
(1) L-227/L-230	Gasket set with Seals	227-61-801-00
(2) L-295/L-297/L-300/R-340 a) L-297 b) L-297 c) L-295/L-300/R-340 d) L-295/L-300	Gasket set with Seals: 30 mm. dia. shaft 24 mm. dia. shaft 30 mm. dia. shaft 24 mm. dia. shaft	297-61-805-00 297-61-801-00 297-61-811-00 297-61-806-00
(3) L-340 L-340 L-340	Gasket set with Seals 24 mm. shaft 30 mm. shaft	339-61-801-00 339-61-802-00
(4) LR-340/2 (2F-340-1), LR-399/2 (2F-400-1), LR-440/2 (2F-440-2) a) LR-340/2 (2F-340-1) b) LR-340/2 (2F-340-1) c) LR-399/2 (2F-400-1) d) LR-440/2 (2F-440-2)	Gasket set with Seals Recoil Start Electric Start Recoil Start Electric Start	338-61-801-00 338-61-802-00 399-61-801-00 399-61-802-00
(5) LB-600/2 (2F-600-1)	Gasket set with Seals	600-61-802-00

Spark Plug Recommendations

Engine Model	Medium Load		Full Load		Racing	
	Bosch	Champion	Bosch	Champion	Bosch	Champion
L-99	W-175-T1	L-97Y	W-225-T1	L-87Y	---	---
L-227	M-225-T1	K-9	M-260-T1	K-7	M-280-T31	K-57R
L-230	M-240-T1	K-8	M-260-T1	K-7	M-280-T31	K-57R
L-295	M-240-T1	K-8	M-240-T1	K-8	M-280-T31	K-57R
R-295	---	---	W-280-T20S	N-60Y	W-310-T17	N-57R
L-297	M-240-T1	K-8	M-240-T1	K-8	M-280-T31	K-57R
L-300	M-240-T1	K-8	M-280-T31	K-7	M-310-T31S	K-54R
L-340	M-240-T1	K-8	M-280-T31	K-7	M-310-T31S	K-54R
R-340	---	---	W-280-T20S	N-60Y	W-310-T17	N-57R
LR-340-2	W-240-T2	N-4	W-260-T2	N-3	W-310-T17	N-57R
LR-399/2	W-240-T2	N-4	W-260-T2	N-3	W-310-T17	N-57R
LR-440/2	W-260-T2	N-4	W-260-T2	N-3	W-310-T17	K-57R
LB-600/2	M-225-T1	K-9	M-240-T1	K-8	---	---



JLO Engines

Conversion Factors/Tables, Reference Data

Metric System

The metric system is based on multiples of ten. Measures of meter and gram are used in multiples of ten up to a thousand and in subdivisions down to 1/1000.

The thousand meter multiple is the kilometer and the thousandth division is the millimeter. These terms are the most common. The same system is used with the gram, the unit of weight. The most common of the weight terms are the gram and kilogram. The most common term for volume is cubic centimeter.

Engine dimensions, including bore and stroke, are normally stated in millimeters, while displacement, which is a volume measurement is stated in cubic centimeters or "cc's".

Conversion Formulas

- One inch equals 25.4 millimeters, and one millimeter equals .039-inch.

The formula for converting millimeters to inches is: $\text{millimeters} \div 25.4 = \text{inches}$.

Inches are converted to millimeters with the formula: $\text{inches} \times 25.4 = \text{millimeters}$.

- One U.S. gallon equals 3.75 liters. One liter equals .264 U.S. gallon.

The formula for converting liters to U.S. gallons is: $\text{liters} \div 3.785 = \text{U.S. gallons}$.

Liters are converted to U.S. quarts with the formula: $\text{liters} \div .946 = \text{U.S. quarts}$.

- U.S. quarts are converted to liters with the formula: $\text{U.S. quarts} \times .946 = \text{liters}$.

- U.S. gallons are converted to liters with the formula: $\text{U.S. gallons} \times 3.785 = \text{liters}$.

U.S. and Metric Bolt Standards

U.S. STANDARD				METRIC STANDARD			
GRADE OF BOLT		SOCKET OR WRENCH SIZE		GRADE OF BOLT		SOCKET OR WRENCH SIZE	
U.S. STANDARD		U.S. REGULAR		METRIC		METRIC	
BOLT DIA.	U.S. DEC. EQUIV.	BOLT HEAD	NUT	BOLT DIA.	U.S. DEC. EQUIV.	BOLT HEAD	NUT
1/4	.250	3/8	7/16	6 mm	.2362	10 mm	10 mm
5/16	.3125	1/2	9/16	8 mm	.3150	14 mm	14 mm
3/8	.375	9/16	5/8	10 mm	.3937	17 mm	17 mm
7/16	.4375	5/8	3/4	12 mm	.4720	19 mm	19 mm
1/2	.500	3/4	13/16	14 mm	.5512	22 mm	22 mm
9/16	.5625	7/8	7/8	16 mm	.6299	24 mm	24 mm
5/8	.625	15/16	1	18 mm	.700	27 mm	27 mm
3/4	.750	1-1/8	1-1/8	22 mm	.8661	32 mm	32 mm
7/8	.875	1-5/16	1-5/16	24 mm	.945	36 mm	36 mm
1	1.000	1-1/2	1-1/2				

Decimal Equivalents

$\frac{1}{32}$ — .015625 $\frac{3}{64}$ — .046875 $\frac{1}{16}$ — .0625 $\frac{3}{32}$ — .09375 $\frac{1}{8}$ — .125 $\frac{5}{64}$ — .078125 $\frac{3}{16}$ — .1875 $\frac{1}{4}$ — .25 $\frac{5}{16}$ — .3125 $\frac{3}{8}$ — .375 $\frac{7}{16}$ — .4375 $\frac{1}{2}$ — .5 $\frac{5}{8}$ — .625 $\frac{3}{4}$ — .75 $\frac{7}{8}$ — .875 1 — 1.0	$\frac{1}{8}$ — .125 $\frac{3}{16}$ — .1875 $\frac{1}{4}$ — .25 $\frac{5}{16}$ — .3125 $\frac{3}{8}$ — .375 $\frac{7}{16}$ — .4375 $\frac{1}{2}$ — .5 $\frac{5}{8}$ — .625 $\frac{3}{4}$ — .75 $\frac{7}{8}$ — .875 1 — 1.0	$\frac{1}{16}$ — .0625 $\frac{3}{32}$ — .09375 $\frac{1}{8}$ — .125 $\frac{5}{64}$ — .078125 $\frac{3}{16}$ — .1875 $\frac{1}{4}$ — .25 $\frac{5}{16}$ — .3125 $\frac{3}{8}$ — .375 $\frac{7}{16}$ — .4375 $\frac{1}{2}$ — .5 $\frac{5}{8}$ — .625 $\frac{3}{4}$ — .75 $\frac{7}{8}$ — .875 1 — 1.0	$\frac{1}{32}$ — .03125 $\frac{3}{64}$ — .046875 $\frac{1}{16}$ — .0625 $\frac{3}{32}$ — .09375 $\frac{1}{8}$ — .125 $\frac{5}{64}$ — .078125 $\frac{3}{16}$ — .1875 $\frac{1}{4}$ — .25 $\frac{5}{16}$ — .3125 $\frac{3}{8}$ — .375 $\frac{7}{16}$ — .4375 $\frac{1}{2}$ — .5 $\frac{5}{8}$ — .625 $\frac{3}{4}$ — .75 $\frac{7}{8}$ — .875 1 — 1.0
--	---	--	---



Cylinder Displacement

An engine's displacement is the volume displaced by the piston in its cylinder as it moves through the stroke. Factors involved in the displacement formula are 1) diameter of cylinder bore 2) length of piston stroke 3) number of cylinders and 4) a constant. The constant is .7854 which is one-fourth of 3.1416, another constant known as "pi". Pi and .7854 are used in formulas relating to dimensions of circles.

Actually, the engine displacement formula is the standard formula for computing the volume of a cylinder of any type with an added factor that represents the number of cylinders in the engine.

The formula is: bore diameter x bore diameter x .7854 x stroke length x number of cylinders = displacement.

Dimensions in inches will give the displacement in cubic inches. Dimensions in millimeters will give the displacement in cubic millimeters, which are converted to the standard measure of cubic centimeters with the formula:

cubic millimeters ÷ 1000 = cubic centimeters.

For an example, compute the displacement of a two-cylinder engine that has a bore of 2.91 inches and a stroke of 2.89 inches. Applying these figures to the formula converts the formula to the equation:

2.91 x 2.91 x .7854 x 2.89 x 2 = displacement in cubic inches.

The equation is worked by multiplying the numbers together, starting at the equation's left and working to the right to preserve order.

The individual steps are:

**2.91 x 2.91 = 8.468
8.468 x .7854 = 6.650
6.650 x 2.89 = 19.218
19.218 x 2 = 38.436 cubic inches displacement.**

Example: compute the displacement of a single-cylinder engine that has a bore of 52 mm, and a stroke of 58 mm.

The equation becomes: 52 x 52 x .7854 x 58 x 1 = displacement in cubic centimeters.

Example: compute the displacement of a single-cylinder engine that has a bore of 52 mm, and a stroke of 58 mm.

The equation becomes: 52 x 52 x .7854 x 58 x 1 = displacement in cubic millimeters. The equation is worked out in these steps:

**52 x 52 = 2704
2704 x .7854 = 2123.721
2123.721 x 58 = 123175.818
123175.818 x 1 = 123175.818 cubic millimeters displacement.**

This is reduced to cubic centimeters by dividing by 1000: 123175.818 ÷ 1000 = 123.175 cubic centimeters.

Horsepower and Torque

Horsepower and torque are measures of engine performance. They are related to the extent that one cannot exist without the other. Torque is the measure of the amount of work an engine can do and horsepower is the measure of the amount of work done in a given time. The time factor for horsepower computations is the engine's crankshaft speed, as measured in revolutions per minute.

Measurements of an engine's torque output require a machine called a dynamometer. This is a large, expensive piece of equipment found primarily in engineering laboratories. However, some of the better-equipped shops have "dynos" for test work.

In U.S. and British systems torque is measured in **foot-pounds**. A foot-pound is a force of one pound exerted on a lever one foot long. Thirty-three thousand foot-pounds of work done in one minute, no matter by what means, equals one horsepower. Because the force exerted by a flywheel or crankshaft acts in a circular direction, the power formula contains the constant **2 pi** to change the rotating force to straight-line force.

The formula is: $2 \pi \times \text{torque} \times \text{rpm} \div 33,000 = \text{horsepower}$.

By eliminating the 2 pi constant and reducing the 33,000 factor accordingly, the formula is reduced to: $\text{torque} \times \text{rpm} \div 5252 = \text{horsepower}$.

Example: compute the horsepower of a twin engine that develops 40 foot-pounds of torque at 6500 rpm.

Applying these figures to the formula gives the equation: $40 \times 6500 \div 5252 = 260,000 \div 5252 = 49.5$ horsepower.

For computing torque when horsepower and rpm's are known, the formula is: $\text{horsepower} \times 5252 \div \text{rpm} = \text{torque}$.

To compute the torque delivered by an engine that delivers 37 hp. at 6,000 rpm the equation is: $37 \times 5252 \div 6000 = 194.324 \div 6000 = 32.4$ foot-pounds of torque.

The metric system's measure for hp is 75 kilogram meters of work in one second. One metric hp. equals .986 U.S. hp.

Power ratings derived with the metric system can be converted to U.S. hp. with the formula: $\text{metric hp.} \times .986 = \text{U.S. hp.}$

An engine that delivers 23 metric hp. delivers 22.678 U.S. hp. ($23 \times .986 = 22.678$)

Convert U.S. hp. to metric hp. with the formula: $\text{U.S. hp.} \div .986 = \text{metric hp.}$

An engine that delivers 36 U.S. hp. delivers 36.51 metric hp. ($36 \div .986 = 36.51$)

Compression Ratio

A cylinder's compression ratio is computed by comparing the cylinder's volume, or its displacement with the total volume of the cylinder and its combustion chamber. Cylinder volume can be determined mathematically but combustion chamber volume must be measured with a liquid.

Cylinder volume is determined in exactly the same manner as for the displacement formula: $\text{bore} \times \text{bore} \times .7854 \times \text{stroke} = \text{volume of one cylinder}$. The measurements can be in either inches or millimeters.

To determine combustion chamber volume pour light oil from beaker into combustion chamber with piston at top-dead-center. The amount of liquid poured into the chamber is determined by subtracting the quantity still in the beaker when the chamber is full from the original quantity. Most beakers are graduated in cubic centimeters. The formula is thus: $\text{Combustion chamber volume} + \text{cylinder volume} \div \text{combustion chamber volume} = \text{compression ratio}$.

Example: consider an engine that has a combustion chamber volume of 18 cc and a cylinder volume of 125 cc. These figures applied to the formula gives the equation: $18 + 125 \div 18 = 143 \div 18 = 7.94$, the engine's compression ratio.

Torque Specifications

Engine Model	Cyl. Hd. Nuts	Cyl. Base Nuts	Intake Manifold or Carb. Adapter	Exhaust Flange	Crankcase Screws	Flywheel Nut
Foot Pounds						
L-99		8	4	8	4	29/32
L-227, L-230 L-295 L-297 L-300 L-340	28/32	16/18	5/7	16/18	7	32/36
R-295	16/18	28/32	5/7	16/18	16/18	79/87
R-340						
LR-340/2 (2F-340-1)						
LR-399/2 (2F-400-2)	28/32	16/18	10	---	16/18	44/50
LR-440/2 (2F-440-2)						
LB-600/2 (2F-600-1)	16/18	28/32	5/7	16/18	16/18	79/87



JLO Engines

Temperature Conversion Chart

Centigrade—Fahrenheit

NOTE: The numbers in boldface refer to the temperature in degrees, either Centigrade or Fahrenheit, which it is desired to convert into the other scale. If converting from Fahrenheit to Centigrade degrees, the equivalent temperature will be found in the left column; while if converting from degrees Centigrade to degrees Fahrenheit, the answer will be found in the column on the right.

Centigrade	Fahrenheit	Centigrade	Fahrenheit	Centigrade	Fahrenheit	Centigrade	Fahrenheit			
-73.3	-100	-148.0	2.8	37	98.6	33.3	92	197.6		
-67.8	-90	-130.0	3.3	38	100.4	33.9	93	199.4		
-62.2	-80	-112.0	3.9	39	102.2	34.4	94	201.2		
-59.4	-75	-103.0	4.4	40	104.0	35.0	95	203.0		
-56.7	-70	-91.0	5.0	41	105.8	35.6	96	204.8		
-53.9	-65	-85.0	5.6	42	107.6	36.1	97	206.6		
-51.1	-60	-76.0	6.1	43	109.4	36.7	98	208.4		
-48.3	-55	-67.0	6.7	44	111.2	37.2	99	210.2		
-45.6	-50	-58.0	7.2	45	113.0	37.8	100	212.0		
-42.8	-45	-49.0	7.8	46	114.8	43	110	230		
-40.0	-40	-40.0	8.3	47	116.6	49	120	248		
-37.2	-35	-31.0	8.9	48	118.4	54	130	266		
-34.4	-30	-22.0	9.4	49	120.2	60	140	284		
-31.7	-25	-13.0	10.0	50	122.0	66	150	302		
-28.9	-20	-4.0	10.6	51	123.8	71	160	320		
-26.1	-15	5.0	11.1	52	125.6	77	170	338		
-23.3	-10	14.0	11.7	53	127.4	82	180	356		
-20.6	-5	23.0	12.2	54	129.2	88	190	374		
-17.8	0	32.0	12.8	55	131.0	93	200	392		
-17.2	1	33.8	13.3	56	132.8	99	210	410		
-16.7	2	35.6	13.9	57	134.6	100	212	414		
-16.1	3	37.4	14.4	58	136.4	104	220	428		
-15.6	4	39.2	15.0	59	138.2	110	230	446		
-15.0	5	41.0	15.6	60	140.0	116	240	464		
-14.4	6	42.8	16.1	61	141.8	121	250	482		
-13.9	7	44.6	16.7	62	143.6	127	260	500		
-13.3	8	46.4	17.2	63	145.4	132	270	518		
-12.8	9	48.2	17.8	64	147.2	138	280	536		
-12.2	10	50.0	18.3	65	149.0	143	290	554		
-11.7	11	51.8	18.9	66	150.8	149	300	572		
-11.1	12	53.6	19.4	67	152.6	154	310	590		
-10.6	13	55.4	20.0	68	154.4	160	320	608		
-10.0	14	57.2	20.6	69	156.2	166	330	626		
-9.4	15	59.0	21.1	70	158.0	171	340	644		
-8.9	16	60.8	21.7	71	159.8	177	350	662		
-8.3	17	62.6	22.2	72	161.6	182	360	680		
-7.8	18	64.4	22.8	73	163.4	188	370	698		
-7.2	19	66.2	23.3	74	165.2	193	380	716		
-6.7	20	68.0	23.9	75	167.0	199	390	734		
-6.1	21	69.8	24.4	76	168.8	204	400	752		
-5.6	22	71.6	25.0	77	170.6	210	410	770		
-5.0	23	73.4	25.6	78	172.4	216	420	788		
-4.4	24	75.2	26.1	79	174.2	221	430	806		
-3.9	25	77.0	26.7	80	176.0	227	440	824		
-3.3	26	78.8	27.2	81	177.8	232	450	842		
-2.8	27	80.6	27.8	82	179.6	238	460	860		
-2.2	28	82.4	28.3	83	181.4	243	470	878		
-1.7	29	84.2	28.9	84	183.2	249	480	896		
-1.1	30	86.0	29.4	85	185.0	254	490	914		
-0.6	31	87.8	30.0	86	186.8	260	500	932		
0.0	32	89.6	30.6	87	188.6	266	510	950		
0.6	33	91.4	31.1	88	190.4	271	520	968		
1.1	34	93.2	31.7	89	192.2	277	530	986		
1.7	35	95.0	32.2	90	194.0	282	540	1004		
2.2	36	96.8	32.8	91	195.8	288	550	1022		
								293	560	1040
								299	570	1058
								304	580	1076
								310	590	1094
								316	600	1112
								321	610	1130
								327	620	1148
								332	630	1166
								338	640	1184
								343	650	1202
								349	660	1220
								354	670	1238
								360	680	1256
								366	690	1274
								371	700	1292
								377	710	1310
								382	720	1328
								388	730	1346
								393	740	1364
								399	750	1382
								404	760	1400
								410	770	1418
								416	780	1436
								421	790	1454
								427	800	1472
								432	810	1490
								438	820	1508
								443	830	1526
								449	840	1544
								454	850	1562
								460	860	1580
								466	870	1598
								471	880	1616
								477	890	1634
								482	900	1652
								488	910	1670
								493	920	1688
								499	930	1706
								504	940	1724
								510	950	1742
								516	960	1760
								521	970	1778
								527	980	1796
								532	990	1814
								538	1000	1832
								566	1050	1922
								593	1100	2012
								621	1150	2102
								649	1200	2192
								677	1250	2282
								704	1300	2372
								732	1350	2462
								760	1400	2552
								788	1450	2642
								816	1500	2732

The formulas at the right may also be used for converting Centigrade or Fahrenheit degrees into the other scale.

$$\text{Degrees Cent., } C^{\circ} = \frac{5}{9} (F^{\circ} + 40) - 40$$

$$\text{Degrees Fahr., } F^{\circ} = \frac{9}{5} (C^{\circ} + 40) - 40$$



Linear Conversions

6x6World.com

Millimeters to Inches

milli- metres	0	1	2	3	4	5	6	7	8	9
	inches									
0	—	0.03937	0.07874	0.11811	0.15748	0.19685	0.23622	0.27559	0.31496	0.35433
10	0.39370	0.43307	0.47244	0.51181	0.55118	0.59055	0.62992	0.66929	0.70866	0.74803
20	0.78740	0.82677	0.86614	0.90551	0.94488	0.98425	1.02362	1.06299	1.10236	1.14173
30	1.18110	1.22047	1.25984	1.29921	1.33858	1.37795	1.41732	1.45669	1.49606	1.53543
40	1.57480	1.61417	1.65354	1.69291	1.73228	1.77165	1.81102	1.85039	1.88976	1.92913
50	1.96850	2.00787	2.04724	2.08661	2.12598	2.16535	2.20472	2.24409	2.28346	2.32283
60	2.36220	2.40157	2.44094	2.48031	2.51969	2.55906	2.59843	2.63780	2.67717	2.71654
70	2.75591	2.79528	2.83465	2.87402	2.91339	2.95276	2.99213	3.03150	3.07087	3.11024
80	3.14961	3.18898	3.22835	3.26772	3.30709	3.34646	3.38583	3.42520	3.46457	3.50394
90	3.54331	3.58268	3.62205	3.66142	3.70079	3.74016	3.77953	3.81890	3.85827	3.89764
100	3.93701	3.97638	4.01575	4.05512	4.09449	4.13386	4.17323	4.21260	4.25197	4.29134
110	4.33071	4.37008	4.40945	4.44882	4.48819	4.52756	4.56693	4.60630	4.64567	4.68504
120	4.72441	4.76378	4.80315	4.84252	4.88189	4.92126	4.96063	5.00000	5.03937	5.07874
130	5.11811	5.15748	5.19685	5.23622	5.27559	5.31496	5.35433	5.39370	5.43307	5.47244
140	5.51181	5.55118	5.59055	5.62992	5.66929	5.70866	5.74803	5.78740	5.82677	5.86614
150	5.90551	5.94488	5.98425	6.02362	6.06299	6.10236	6.14173	6.18110	6.22047	6.25984
160	6.29921	6.33858	6.37795	6.41732	6.45669	6.49606	6.53543	6.57480	6.61417	6.65354
170	6.69291	6.73228	6.77165	6.81102	6.85039	6.88976	6.92913	6.96850	7.00787	7.04724
180	7.08661	7.12598	7.16535	7.20472	7.24409	7.28346	7.32283	7.36220	7.40157	7.44094
190	7.48031	7.51969	7.55906	7.59843	7.63780	7.67717	7.71654	7.75591	7.79528	7.83465
200	7.87402	7.91339	7.95276	7.99213	8.03150	8.07087	8.11024	8.14961	8.18898	8.22835
210	8.26772	8.30709	8.34646	8.38583	8.42520	8.46457	8.50394	8.54331	8.58268	8.62205
220	8.66142	8.70079	8.74016	8.77953	8.81890	8.85827	8.89764	8.93701	8.97638	9.01575
230	9.05512	9.09449	9.13386	9.17323	9.21260	9.25197	9.29134	9.33071	9.37008	9.40945
240	9.44882	9.48819	9.52756	9.56693	9.60630	9.64567	9.68504	9.72441	9.76378	9.80315
250	9.84252	9.88189	9.92126	9.96063	10.00000	10.0394	10.0787	10.1181	10.1575	10.1969
260	10.2362	10.2756	10.3150	10.3543	10.3937	10.4331	10.4724	10.5118	10.5512	10.5906
270	10.6299	10.6693	10.7087	10.7480	10.7874	10.8268	10.8661	10.9055	10.9449	10.9843
280	11.0236	11.0630	11.1024	11.1417	11.1811	11.2205	11.2598	11.2992	11.3386	11.3780
290	11.4173	11.4567	11.4961	11.5354	11.5748	11.6142	11.6535	11.6929	11.7323	11.7717
300	11.8110	11.8504	11.8898	11.9291	11.9685	12.0079	12.0472	12.0866	12.1260	12.1654
310	12.2047	12.2441	12.2835	12.3228	12.3622	12.4016	12.4409	12.4803	12.5197	12.5591
320	12.5984	12.6378	12.6772	12.7165	12.7559	12.7953	12.8346	12.8740	12.9134	12.9528
330	12.9921	13.0315	13.0709	13.1102	13.1496	13.1890	13.2283	13.2677	13.3071	13.3465
340	13.3858	13.4252	13.4646	13.5039	13.5433	13.5827	13.6220	13.6614	13.7008	13.7402
350	13.7795	13.8189	13.8583	13.8976	13.9370	13.9764	14.0157	14.0551	14.0945	14.1339
360	14.1732	14.2126	14.2520	14.2913	14.3307	14.3701	14.4094	14.4488	14.4882	14.5276
370	14.5669	14.6063	14.6457	14.6850	14.7244	14.7638	14.8031	14.8425	14.8819	14.9213
380	14.9606	15.0000	15.0394	15.0787	15.1181	15.1575	15.1969	15.2362	15.2756	15.3150
390	15.3543	15.3937	15.4331	15.4724	15.5118	15.5512	15.5906	15.6299	15.6693	15.7087
400	15.7480	15.7874	15.8268	15.8661	15.9055	15.9449	15.9843	16.0236	16.0630	16.1024
410	16.1417	16.1811	16.2205	16.2598	16.2992	16.3386	16.3780	16.4173	16.4567	16.4961
420	16.5354	16.5748	16.6142	16.6535	16.6929	16.7323	16.7717	16.8110	16.8504	16.8898
430	16.9291	16.9685	17.0079	17.0472	17.0866	17.1260	17.1654	17.2047	17.2441	17.2835
440	17.3228	17.3622	17.4016	17.4409	17.4803	17.5197	17.5591	17.5984	17.6378	17.6772
450	17.7165	17.7559	17.7953	17.8346	17.8740	17.9134	17.9528	17.9921	18.0315	18.0709
460	18.1102	18.1496	18.1890	18.2283	18.2677	18.3071	18.3465	18.3858	18.4252	18.4646
470	18.5039	18.5433	18.5827	18.6220	18.6614	18.7008	18.7402	18.7795	18.8189	18.8583
480	18.8976	18.9370	18.9764	19.0157	19.0551	19.0945	19.1339	19.1732	19.2126	19.2520
490	19.2913	19.3307	19.3701	19.4094	19.4488	19.4882	19.5276	19.5669	19.6063	19.6457
500	19.6850	19.7244	19.7638	19.8031	19.8425	19.8819	19.9213	19.9606	20.0000	20.0394
510	20.0787	20.1181	20.1575	20.1969	20.2362	20.2756	20.3150	20.3543	20.3937	20.4331
520	20.4724	20.5118	20.5512	20.5906	20.6299	20.6693	20.7087	20.7480	20.7874	20.8268
530	20.8661	20.9055	20.9449	20.9843	21.0236	21.0630	21.1024	21.1417	21.1811	21.2205
540	21.2598	21.2992	21.3386	21.3780	21.4173	21.4567	21.4961	21.5354	21.5748	21.6142



JLO Engines

Specifications

Engine Specifications

Model	L-99 (IF-100-1)		L-230 (IF-250-1)		L-295 (IF-295-1)
Bore	2.165"		2.756"		2.933"
Stroke	1.660"		2.283"		2.637"
Displacement	100 cc.		223 cc		292 cc
Compression Ratio	8.5 to 1		7:1 (Actual)		8:1 (Actual)
Maximum Torque	5.05 Ft./Lbs. at 4000 rpm		13.6 Ft./Lbs. at 5600 rpm		19 Ft./Lbs. at 5000/5500 rpm
Fuel Consumption Under Full Load	.83 Lbs./Hph at 5500 rpm		.82 Lbs./Hph at 5500 rpm		.74 Lbs./Hph at 6000 rpm
Brake H.P./Rpm	4.75 HP at 5500/6000 rpm		15½ HP at 6000 rpm		21.5 HP at 6000 rpm
Base Mounting Hole	8 mm.		⅜"-18 UNC		
Cylinder	Aluminum with Cast Iron Sleeve				
Connecting Rod Bearing Upper	Needle				
Lower	Needle				
Connecting Rod Material	Forged Steel				
Main Bearing	2 Heavy Duty Ball Bearings				
Ignition	Bosch E-120		Bosch RCP-1		Bosch SCP-1V
Ignition Coil	Internal Coil		Bosch Type PA		
Lighting Coil	Not available		12 Volt, 40 Watt		12 Volt, 75 Watt
Contact Breaker Gap	.011" to .019"		.014" to .018"		
Ignition Setting Before TDC	.082" to .098"		.110" to .126"		.118" to .138"
Spark Plugs Thread	14 mm.		18 mm.		
Gap	.016" to .020"		.016" to .020"		.016" to .020"
Type	Bosch	Champion	Bosch	Champion	Bosch
Medium Load	W-175-T1	L-97Y	M-240-T-1	K-9	M-240-T-1
Full Load	W-225-T1	L-87Y	M-260-T-1	K-7	M-260-T-1
Racing			M-280-T-31	K-57-R	M-280-T-31
Battery	12 Volt, 20 Hour Discharge (32 Amp Hour)				
Rotation	Counter-Clockwise Viewed From P.T.O. End				
Fuel-Oil Mixture	20:1 (1 Qt. Oil to 5 Gallons of Gasoline)				
Lubrication	Good Brand of Premium Gasoline and Special 2-Cycle Engine Oil				
Carburetor Type	HL		WR or HR		WD or HD
Starter	Rewind only		Rewind Type, Standard, Electric, Optional		
Rope Material	Nylon		Nylon		Steel
Approx. Weight (Lbs.)	14		29		48.5

* — Cam Fully Advanced x W/2 H.D. Carburetors and open pipe. † W/electric starter and less carburetor, air filter and exhaust.

+ — Applies to all current axial fan twin-cylinder models. However, on LR-340/2 models with serial numbers up to and including No. 14850, and on LR-399 2 models with serial numbers up to and including No. 30298, the ignition setting is .104" to .124" before T.D.C.

Horsepower ratings established in accordance with specification SAE-J607, except that production engines will produce not less than 92% of the rated horsepower when used with approved carburetor-muffler combinations.

L-340 (1F-340-1)	LR-340/2 (2F-340-1)	LR-399/2 (2F-400-1)	LR-440/2 (2F-440-2)	LB-600 (2F-600-1)
3.149"	2.362"	2.559"	2.658"	2.953
2.637"	2.362"	2.362"	2.362"	2.366
336 cc	339 cc	398 cc	428 cc	594 cc
7.8:1 (Actual)	7.5:1 (Actual)	7.5:1 (Actual)	7.5:1 (Actual)	11.5 to 1
20.2 Ft./Lbs. at 6000 rpm	21.6 Ft./Lbs. at 6250 rpm	25.2 Ft./Lbs. at 6000 rpm	28.4 Ft./Lbs. at 6000 rpm	36 Ft./Lbs. at 5000 rpm
.82 Lbs./Hph at 5500/6000 rpm	.75 Lbs./Hph at 6250 rpm	.75 Lbs./Hph at 6250 rpm	.75 Lbs./Hph at 6000 rpm	836 Lbs./Hph at 4500 rpm
23.5 HP at 6000 rpm	26 HP at 6250 rpm	30 HP at 6250 rpm	35 HP at 6750 rpm	32.5 HP at 5000 rpm *
3/16"-14 UNC				1/2"-13 UNC
Aluminum with Cast Iron Sleeve				
Needle				
Needle				
Forged Steel				
	1 Roller Bearing, 2 Heavy Duty Ball Bearings		2 Heavy Duty Ball Bearings	
Bosch SCP-1V	Bosch SCP-2V		Bosch SCP-1V	
Bosch Type PA				
12 Volt, 75 Watt				
.014" to .018"				
.118" to .138"	.083" to .102"* +		.014" to .018"	
18 mm	14 x 1.25 mm Long Reach Type		18 mm	
.016" to .020"	.016" to .020"		.016" to .020"	
Champion	Bosch	Champion	Bosch	Champion
K-9	W-240-T-2	N-4	M-225-T-1	K-9
K-7	W-260-T-2	N-3	M-240-T-1	K-8
K-57-R	W-310-T-17	N-57-R		
12 Volt, 20 Hour Discharge (32 Amp Hour)				
Counter-Clockwise Viewed From P.T.O. End				
20:1 (1 Qt. Oil to 5 Gallons of Gasoline)				
Good Brand of Premium Gasoline and Special 2-Cycle Engine Oil				
WD or HD	WD or HD	WD or HD	WD or HD	WD or HD
Rewind Type, Standard; Electric, Optional				Electric, W/Emergency Pulley
Steel	Steel	Steel	Steel	Nylon
49.7	62	62	62	85†

Manufacturing Company reserves the right to change materials and/or specifications without notice.

