



# Tri-Sport

MTS and TS SERIES  
PARTS LIST

ALSPORT, INCORPORATED

84 Whittlesey, Norwalk, Ohio 44857 •

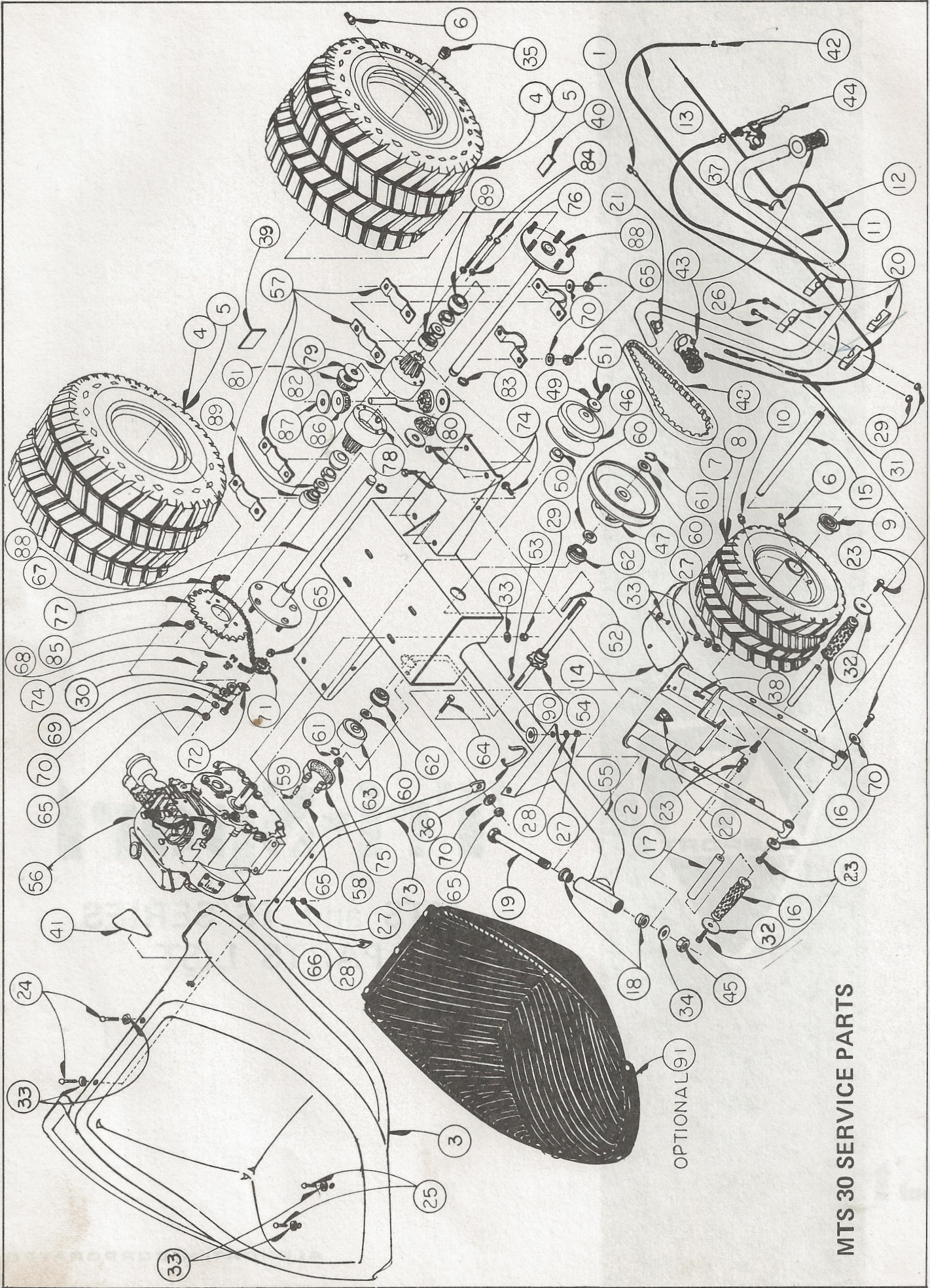

MTS 30 SERVICE PARTS

MTS 30 SERVICE PARTS

Item No.	Part No.	Quan.	Description
1	725-105	1	Kill Wire Ass'y.
2	731-108	1	Front Fork Ass'y.
3	751-102	1	Body and Seat Panel Ass'y.
4	734-106	2	Tire (18 x 8.50-8; 2 Ply)
5	734-109	2	Wheel (18 x 8.50)
6	734-107	3	Tire Valve w/Cap
7	734-114	1	Tire 6.00 x 15-6
8	734-115	1	Wheel & Hub Weld Ass'y.
9	741-102	2	Front Wheel Bearing
10	737-101	1	Grease Fitting 1/4-28 Strg't/ht
11	720-103	1	Handlebar (14" Rise)
12	746-105	1	Brake Cable and Housing (Complete w/Fittings)
13	746-104	1	Throttle Cable and Housing (Complete w/Fittings)
14	733-111	1	Front Fender
15	711-103	1	Front Axle
16	720-102	2	Foot Rest Grip
17	711-101	2	Foot Rest Mounting Bar
18	748-100	2	Bearing, Front Fork
19	710-100	1	King Bolt (Fork) 3/4-10N.C. x 5 1/2 Lg. (Pl'td.)
20	711-107	4	Handlebar Mount
21	725-107	1	Push Button Switch (Magneto Kill)
22	759-100	1	"Alspott" Decal
23	710-118	6	Bolt, Hex Hd. 3/8-24 N.F. x 3/4 Lg. Whiz-Lok (Pl'td.)
24	710-130	2	Bolt, Hex Hd. 1/4-20 N.C. x 1 3/4 Lg. (Pl'td.)
25	710-123	2	Bolt, Carriage Hd. 1/4-20 N.C. x 1 1/2 Lg. (Pl'td.)
26	710-105	4	Bolt, Hex Hd. 5/16-24 N.F. x 2 1/4 Lg. (Pl'td.)
27	712-101	6	Nut, Hex 1/4-20 N.C. (Pl'td.)
28	736-103	6	Lockwasher 1/4 (Spring Type - Med.)
29	712-102	8	Hex Lock Nut 5/16-24 N.F. (Pl'td.)
30	736-119	1	Lockwasher, External Tooth (1/2")
31	749-103	2	Spiralwrap 1/4" O.D. x 3 Lg.
32	736-106	2	Snubbing Washer
33	736-104	12	Flat Washer 5/16 SAE (Pl'td.)
34	736-117	1	Flat Washer 3/4 SAE (Pl'td.)
35	712-104	10	Lug Nut 1/2-20 SAE (60° chamfer)
36	749-104	2	Cable Tie Wrap (Frame)
37	749-101	2	Cable Tie Wrap (Handlebar)
38	710-131	2	Bolt, Hex Hd. 1/4-20 N.C. x 1" Lg. (Pl'td.)
39	759-103	1	Serial Plate
40	759-102	1	"Off-Road" Sticker
41	759-101	2	Tri-Sport Sticker
42	746-103	1	Cable Stop (Throttle)
43	720-101	1	Throttle Twist Control w/Dummy Grip
44	746-100	1	Brake Lever w/Adjusting Screw (7/8 Dia.)
45	712-105	1	Hex Jam Lock Nut (3/4-10 N.C.) Pl'td.
46	717-103	1	Torque Converter (Driver) 3/4" Dia. Bore
47	717-104	1	Torque Converter (Driven) 5/8" Dia. Bore
48	754-100	1	"V" Type Drive Belt
49	736-115	1	Flat Washer 3/8" I.D. - spc'l. (Pl'td.)
50	750-101	1	Spacer 1" O.D. x 3/4" I.D. x 9/16 Lg. (Pl'td.)

734-102 Complete Wheel & Tire Ass'y. consists of (1) each of these parts

734-103 Complete Front Wheel & Tire Ass'y.

May be furnished as a complete kit - specify Part No. 717-102

Item No.	Part No.	Quan.	Description
51	710-122	1	Bolt, Hex Hd. 3/8-24 N.F. x 2" Lg. Whiz-Lok
52	714-102	1	Key 3/16 x 3/16 x 2 Lg.
53	714-101	1	Key 3/16 x 3/16 x 9/16 Lg.
54	733-109	1	Sprocket & Jackshaft Weld Ass'y.
55	733-107	1	Power Frame & Tongue Weld Ass'y.
56	752-101	1	Teumseh 3 H.P. Engine (Complete)
57	749-100	4	3/4" Pillow Block Housing
58	757-103	1	Brake Band
59	757-104	1	Brake Band Pin w/Set Screw
60	736-100	3	Washer (Spc'l.) 1" O.D. x 5/8 I.D.
61	716-102	2	Retaining Ring 5/8 Dia. Hvy. Duty
62	741-100	2	Ball Bearing w/Retaining Ring (5/8 Dia. Bore)
63	757-101	1	Brake Drum (2 1/2" O.D. x 5/8 Dia. Bore)
64	710-116	1	Bolt, Hex Hd. (3/8-24 N.F. x 1 3/4 Lg.), Pl'td.
65	712-100	13	Hex Lock Nut (3/8-24 N.F.)
66	710-110	4	Bolt, Hex Hd. 5/16-24 N.F. x 1 3/4 Lg. (Pl'td.)
67	713-103	1	Drive Chain ASA No. 40 Roller Chain x 57 Pitches
68	713-100	1	Master Link w/Spring Clip (ASA No. 40)
69	710-113	1	Bolt, Hex Hd. 3/8-24 N.F. x 1 1/2 Lg. (Pl'td.)
70	736-102	13	Flat Washer 3/8 SAE (Pl'td.)
71	748-110	1	Idle Sprocket
72	733-125	1	Chain Idler Arm
73	733-122	1	Seat Support Tube Brace
74	710-125	11	Bolt, Hex Hd. 3/8-24 N.F. x 7/8 Lg. (Pl'td.)
75	712-103	1	Hex Nut 3/8-24 N.F. (Pl'td.)
76	736-104	4	Flat Washer 5/16 SAE
77	748-106	1	Sprocket 45T for ASA No. 40 R.C.
78	719-100	1	Differential Case Half (RH)
79	719-101	1	Differential Case Half (LH)
80	711-102	1	Carrier Pin
81	748-103	2	Carrier Gear
82	736-108	2	Axle Thrust Washer
83	716-101	2	Retaining Ring (3/4 Dia.)
84	710-109	4	Bolt, Hex Hd. 5/16-18 N.C. x 3 1/2 Lg.
85	712-110	4	Hex Lock Nut 5/16-18 N.C.
86	748-104	2	Axle Gear
87	736-107	2	Carrier Thrust Washer
88	738-101	2	Differential Axle & Wheel Hub Weld Ass'y.
89	741-101	4	3/4" Bearing w/Eccentric Lock Collar
90	735-100	2	Rubber Grommet
91	723-102	1	Seat Cushion w/Snaps

These parts consist of (1) complete rear carrier ass'y. Part No. 760-101

TRI SPORT TS 50 MODEL  
SERVICE PARTS

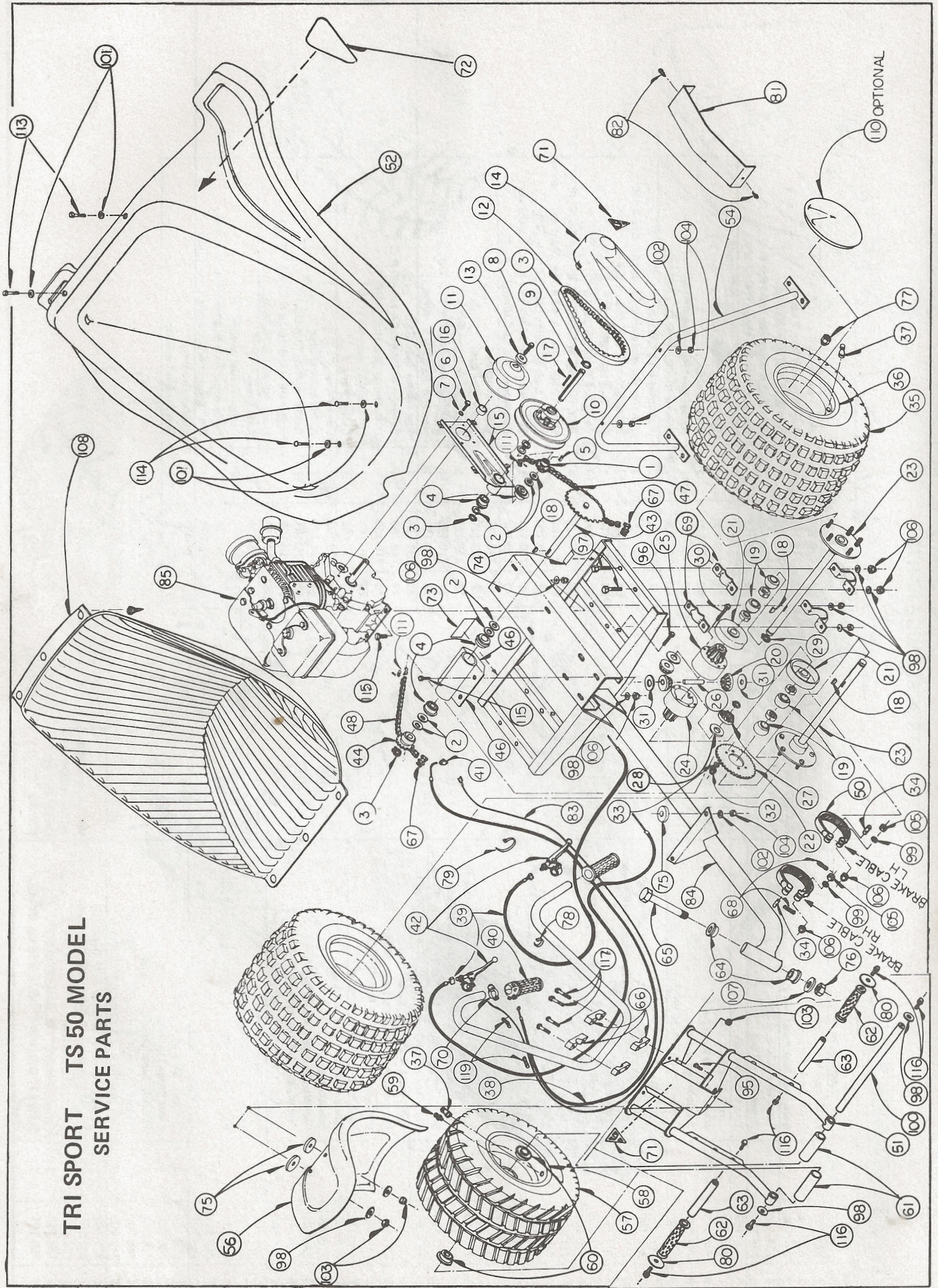

TRI SPORT TS 100 MODEL  
SERVICE PARTS



TRI SPORT TS 125 MODEL  
SERVICE PARTS

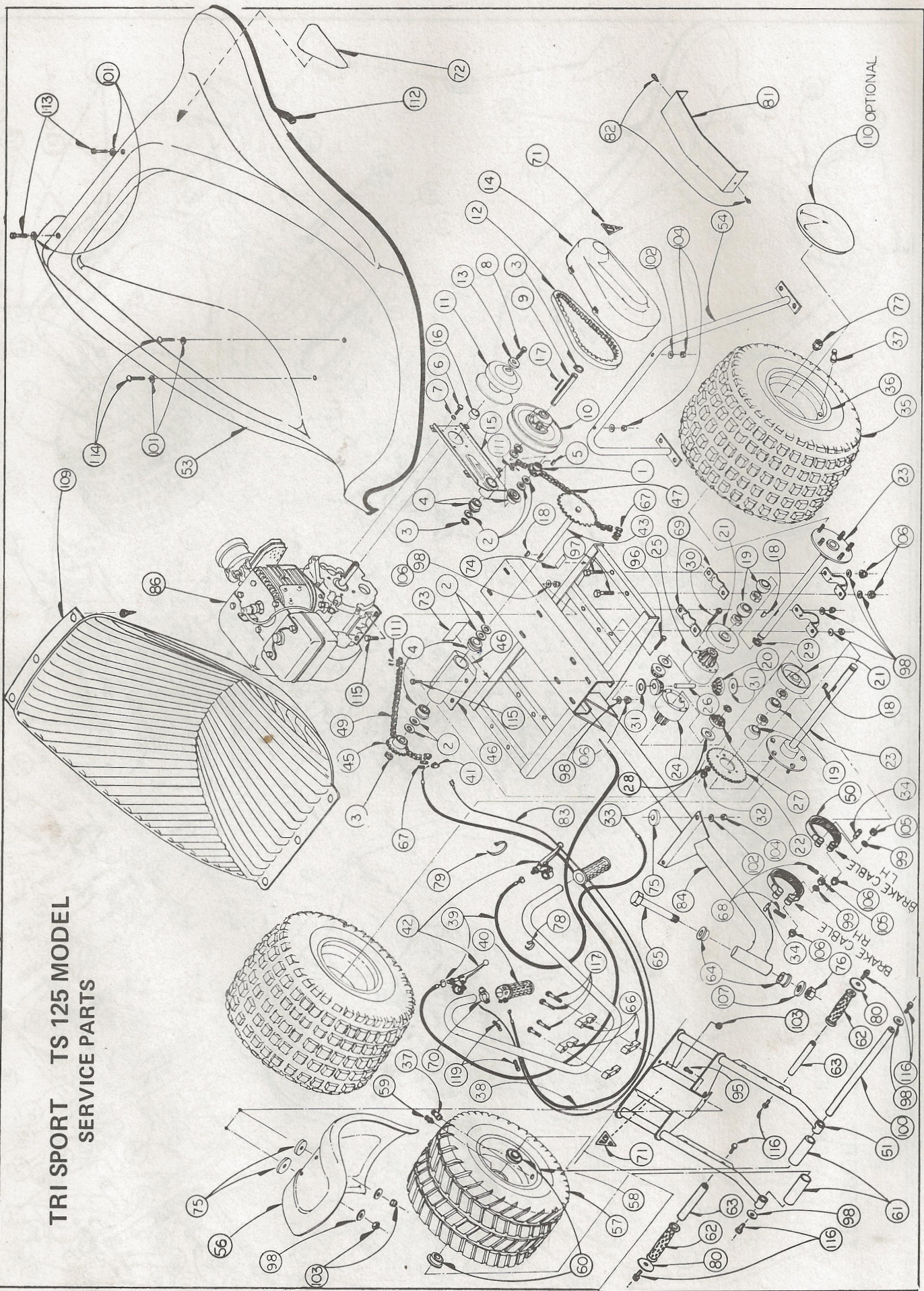

**TRI-SPORT  
DEALER PARTS LIST  
TS 50 - 100 - 125**

PARTS REQ'D.			PART NO.	ITEM	DESCRIPTION	
	TS50	TS 50			TS 50 SERVICE PARTS	
	TS100	TS100			TS100 SERVICE PARTS	
TS125		TS125			TS125 SERVICE PARTS	
1	1	1	748-101	1	Sprocket, 10T No. 41 R.C.	
10	10	10	736-100	2	Washer, 1" O.D. x 5/8 I.D.	
3	3	3	716-100	3	Retaining Ring (5/8 Dia. Std.)	
4	4	4	741-100	4	Ball Bearing w/Retaining Ring	
1	1	1	714-101	5	Key 3/16 x 3/16 x 9/16 Lg.	
4	4	4	710-121	6	Bolt, Hex Hd. 5/16-24 N.F. x 3/4 Lg. (Pl'td.)	
4	4	4	736-105	7	Lockwasher 5/16 Spring Type (Med.)	
1	1	1	710-122	8	Bolt, Hex Wsh'r. Hd. 3/8-24 N.F. x 2 Lg. (Pl'td.)	
1	1	1	711-105	9	Jackshaft (Torque Converter)	May Be Furnished as a Complete Kit...Specify Part No. 717-100
1	1	1	717-106	10	Torque Converter (Driven) 5/8 Dia. Bore	
1	1	1	717-107	11	Torque Converter (Driver) 3/4 Dia. Bore	
1	1	1	754-101	12	Assymetric Drive Belt	
1	1	1	736-115	13	Washer 3/8 I.D. Spc'l. (Pl'td.)	
1	1	1	751-104	14	Converter Cover	
1	1	1	733-124	15	Engine Mounting Brk't.	
1	1	1	750-105	16	Engine Spacer	
1	1	1	714-102	17	Key 3/16 x 3/16 x 2 Lg.	
3	3	3	714-100	18	Woodruff Key, No. 9, Type 606	
4	4	4	741-101	19	Bearing, 3/4" I.D. w/Eccentric Lock Collar	
2	2	2	748-104	20	Axle Gear	
2	2	2	757-102	21	Brake Drum w/Set Screw	
1	1	1	748-102	22	35T, No. 40A Sprocket	
2	2	2	738-102	23	Wheel Hub & Axle Weld Ass'y.	
1	1	1	719-100	24	Differential Case Half (R.H.)	These Parts Consist of One Complete Rear Carrier Ass'y. Part No. 760-102
1	1	1	719-101	25	Differential Case Half (L.H.)	
1	1	1	711-102	26	Carrier Pin	
2	2	2	748-103	27	Carrier Gear	
2	2	2	736-108	28	Axle Thrust Washer	
2	2	2	716-101	29	Retaining Ring (3/4" Dia.)	
4	4	4	710-109	30	Hex Hd. Bolt 5/16-18 N.C. x 3 1/2 Lg.	
2	2	2	736-107	31	Carrier Thrust Washer	
4	4	4	712-110	32	Hex Lock Nut 5/16-18 N.C.	
4	4	4	736-104	33	Flat Washer 5/16 SAE	
2	2	2	757-104	34	Brake Pin w/Set Screw	
2	2	2	734-111	35	Rear Tire (21 x 11.00-8 Compass)	Purchase As A Complete Ass'y. Only...Part No. 734-100
2	2	2	734-110	36	Wheel (21 x 11.00-8)	
3	3	3	734-107	37	Tire Valve w/Cap	
1	1	1	746-102	38	Throttle Cable w/Housing & Fittings	
2	2	2	746-101	39	Brake Cable w/Housing & Fittings	
1	1	1	720-101	40	Throttle Twist Grip w/Dummy Grip	
1	1	1	746-103	41	Throttle Cable Stop	
2	2	2	746-100	42	Brake Lever (LH) w/Adjusting Nut 7/8 Dia.	
1	1	1	733-103	43	Sprocket & Shaft Weld Ass'y. (40A32)	
	1	1	748-111	44	Sprocket 40B 10, 5/8 Dia. Bore	
1			748-107	45	Sprocket 40B 16, 5/8 Dia. Bore	
1	1	1	733-104	46	Jackshaft Housing Weldment	
1	1	1	713-101	47	Primary Chain (No. 40 ASA x 43 Pitches)	
	1	1	713-102	48	Drive Chain (No. 40 ASA x 51 Pitches)	
1			713-104	49	Drive Chain (No. 40 ASA x 54 Pitches)	
2	2	2	757-100	50	Brake Band	
1		1	733-101	51	Front Fork Weld Ass'y. (Std.)	
		1	751-100	52	Body & Seat Panel (Std.)	
1	1		751-103	53	Body & Seat Panel (Deluxe)	
1	1	1	733-102	54	Body & Seat Brace Bracket	
1	1	1	720-100	55	Handlebar (18" Rise)	
1		1	751-101	56	Front Fender	
1	1	1	734-106	57	Tire (18 x 8.50-8, 2 Ply)	Purchase as a Complete Ass'y. Only 734-101.
1	1	1	734-108	58	Front Wheel & Hub Weld Ass'y.	Includes (1) of Item 37 also.
1	1	1	737-101	59	Grease Fitting 1/4-28 SAE Strgh't	
2	2	2	741-102	60	Wheel Bearing, 3/4 Dia.	

**TRI-SPORT  
DEALER PARTS LIST  
TS 50 - 100 - 125**

PARTS REQ'D.			PART NO.	ITEM	DESCRIPTION
		TS50	TS 50		TS 50 SERVICE PARTS
	TS100		TS100		TS100 SERVICE PARTS
TS125			TS125		TS125 SERVICE PARTS
2	2	2	750-100	61	Front Wheel Spacer
2	2	2	720-102	62	Foot Rest Grip
2	2	2	711-101	63	Foot Rest Mounting Bar
2	2	2	748-100	64	Bearing, Front Fork
1	1	1	710-100	65	King Bolt (Fork) 3/4-10 N.C. x 5 1/2 Lg. (Pl'td.)
4	4	4	711-107	66	Handle Bar Mount
2	2	2	713-100	67	Master Link w/Spring Clip (ASA No. 40 Roller Chain)
2	2	2	732-100	68	Compression Spring (Brake Return)
4	4	4	749-100	69	Pillow Block Bearing Housing
1	1	1	725-107	70	Push Button Switch (Magneto Kill)
1	1	1	759-100	71	"Alsport" Decal
2	2	2	759-101	72	Tri-Sport Decal
1	1	1	759-103	73	Serial Plate
1	1	1	759-102	74	"Off Road" Sticker
4	4	4	735-100	75	Rubber Grommet
1	1	1	712-105	76	Hex Lock Jam Nut 3/4-10 N.C. (Pl'td.)
10	10	10	712-104	77	Lug Nut 1/2-20 N.F. (60° Chamfer)
2	2	2	749-102	78	Cable Tie Wrap (Handlebars)
2	2	2	749-104	79	Cable Tie Wrap (Frame)
2	2	2	736-106	80	Snubbing Washer
1	1	1	733-105	81	Brake Splash Shield (LH Mount Only)
2	2	2	710-127	82	Self Tapping Screw, Hex Wash'r No. 8-32 x 1/2 Lg. (Pl'td.)
1	1	1	725-100	83	Magneto Ground Wire Ass'y.
1	1	1	733-100	84	Frame Weld Ass'y.
1	1	1	752-102	85	5 H.P. Tecumseh Engine w/Light Coil
1			752-104	86	7 H.P. Tecumseh Engine w/o Light Coil
	1		733-120	87	Fork Weld Ass'y for Shock Mounting
	2		749-106	88	Shock Absorber
	2		733-128	89	Spindle Mounts
	2		750-107	90	Bolt Bushing
	4		710-116	91	Bolt, Hex Hd. 3/8-24 N.F. x 1 3/4 Lg. (Pl'td.)
	2		710-102	92	Bolt, Hex Hd. 3/8-24 N.F. x 2 Lg. (Pl'td.)
	4		736-102	93	Flat Washer 3/8 U.S.S. (Pl'td.)
	2		712-100	94	Hex Lock Nut 3/8-24 N.F. (Pl'td.)
2	2	2	710-128	95	Bolt, Hex Hd. 5/16-24 N.F. x 1 Lg. (Pl'td.)
2	2	2	710-107	96	Bolt, Hex Hd. 3/8-24 N.F. x 3 Lg. (Pl'td.)
8	8	8	710-102	97	Bolt, Hex Hd. 3/8-24 N.F. x 2 Lg. (Pl'td.)-Same as Item 92
24	24	24	736-102	98	Flat Washer 3/8 U.S.S. (Pl'td.) - Same as Item 93
2	2	2	736-101	99	Lockwasher 3/8 Spring Type (Med.)
1	1	1	711-100	100	Front Axle
4	4	4	736-104	101	Flat Washer 5/16 SAE (Pl'td.) - Same as Item 28
4	4	4	736-103	102	Lockwasher 1/4" Spring Type (Med.)
6	6	6	712-106	103	Hex Lock Nut 5/16-24 N.F. (Pl'td.)
4	4	4	712-101	104	Hex Nut 1/4-20 N.C. (Pl'td.)
2	2	2	712-103	105	Hex Nut 3/8-24 N.F. (Pl'td.)
18	18	18	712-100	106	Hex Lock Nut 3/8-24 N.F. (Pl'td.)-Same as Item 94
1	1	1	736-117	107	Flat Washer 3/4 SAE (Pl'td.)
		1	723-100	108	Seat Pad (Std.) - OPTIONAL
1	1		723-101	109	Seat Pad (Deluxe)
2	2	2	734-113	110	Hub Cap - OPTIONAL
2	2	2	713-106	111	Half Link w/Cotter (No. 40 ASA Roller Chain)
1	1		749-105	112	Body Trim Molding x 146" Lg.
2	2	2	710-130	113	Bolt, Hex Hd. 1/4-20 N.C. x 1 3/4 Lg. (Pl'td.)
2	2	2	710-123	114	Bolt, Carriage Hd. 1/4-20 N.C. x 1 1/2 Lg. (Pl'td.)
8	8	8	710-125	115	Bolt, Hex Hd. 3/8-24 N.F. x 7/8 Lg. (Pl'td.)
6	6	6	710-118	116	Bolt, Hex Whiz Lok 3/8-24 N.F. x 3/4 Lg. (Pl'td.)
4	4	4	710-105	117	Bolt, Hex Hd. 5/16-24 N.F. x 2 1/4 Lg. (Pl'td.)
	1		751-106	118	Front Fender (Shock Mount)-
3	3	3	749-103	119	Spiral Wrap 1/4" O.D. x 3 Lg.

Furnished As An Optional  
Kit on TS50 & TS125.  
Specify Kit Part No. 760-114



ITEM	PART NO.	QUAN.	DESCRIPTION
1	725-102	1	Headlight
2	725-101	1	Tail Light (Red)
3	725-104	1	Toggle Switch (2 Position)
4	733-121	1	Headlight Bracket
5	725-108	1	Wire Harness
6	728-100	2	Pop Rivet 3/16 Dia. x 3/8 Grip
7	724-101	1	Dune Flag w/Blinker (Optional)
8	725-109	1	Butt Connector

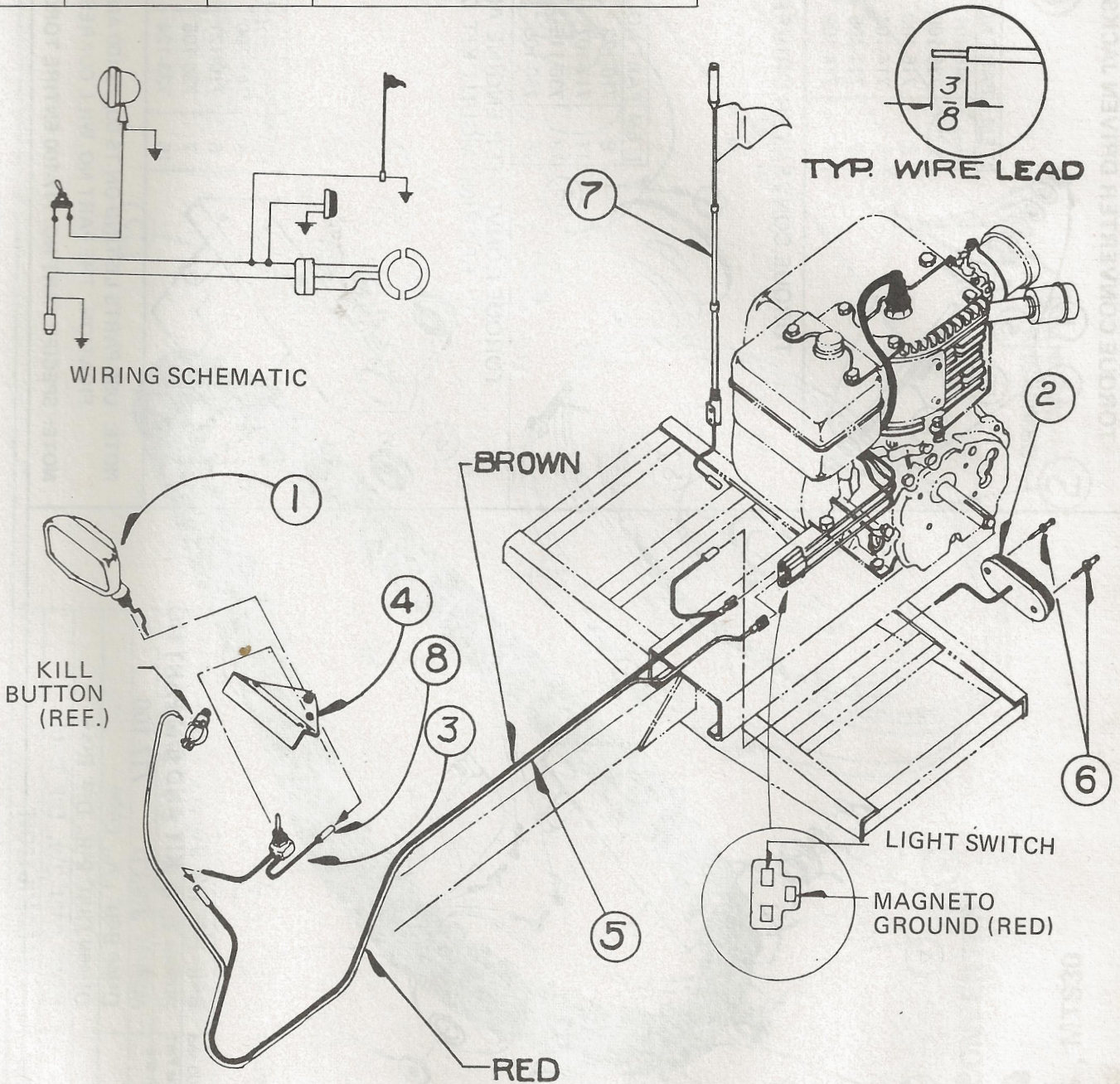
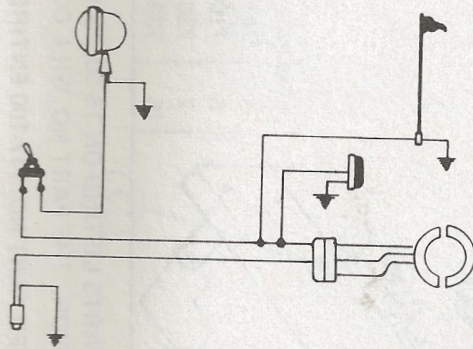

WIRING INST'N. TRI-SPORT  
TS50, TS100, & TS125

760-117

**TORQUE CONVERTER DRIVEN JACKSHAFT KIT 745-100**

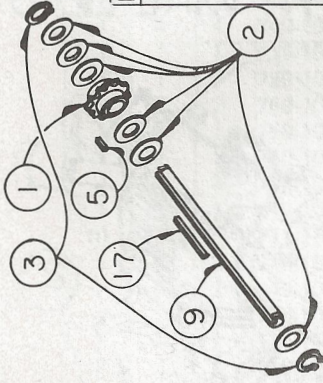

ITEM	PART NO.	QUAN.	DESCRIPTION
1	748-101	1	Sprocket 10T
2	736-100	6	Washer
3	716-100	2	Retaining Ring
5	714-101	1	Key 3/16 Sq x 9/16
9	711-105	1	Jackshaft
17	714-102	1	Key 3/16 Sq x 2

**TORQUE CONVERTER DRIVER KIT 745-101**

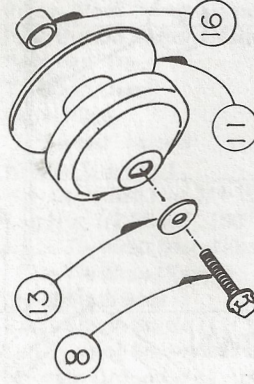

ITEM	PART NO.	QUAN.	DESCRIPTION
8	710-122	1	Bolt, Hex 3/8 NF x 2
11	717-107	1	Driver Unit
13	736-115	1	Washer
16	750-105	1	Engine Spacer

**TORQUE CONVERTER ENGINE AND JACKSHAFT BEARING MOUNT KIT 745-102**

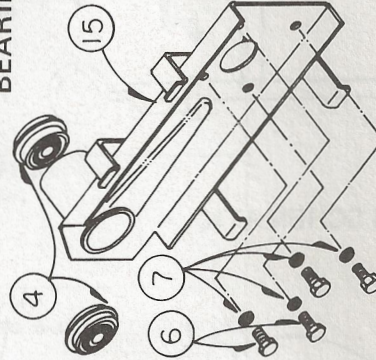

ITEM	PART NO.	QUAN.	DESCRIPTION
4	741-100	2	Ball Bearing
6	710-121	4	Bolt, Hex 5/16 NF x 3/4
7	736-105	4	Lockwasher 1/4
15	733-124	1	Mount'g. Brk't

**NOTE:** USE PARTS LISTING ON TS 50, TS 100 AND TS 125 FOR IDENTIFICATION. THE PART NO. WILL CORRESPOND WITH THE ITEM NO.

**NOTE:** SPECIFY PART NO. 717-100 ENTIRE TORQUE CONVERTER ASS'Y.

**TORQUE CONVERTER SERVICE PARTS**

TS50, TS100, AND TS125

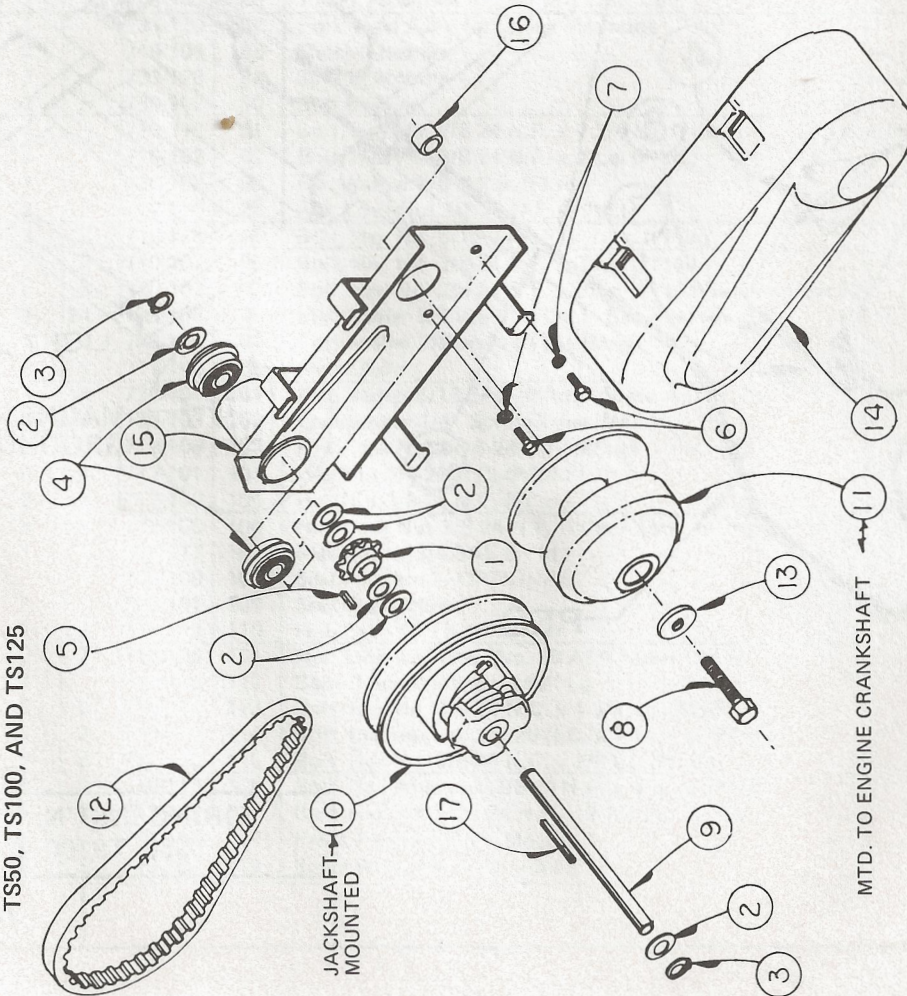

**NOTE:** Use Parts List on TS50, TS100 and TS125 for identification. The Part Number will correspond with the Item Number.

**KIT AND B/M PART NO. 717-100**

ITEM	PART NO.	QUAN.	DESCRIPTION
1	717-103	1	Driver Unit, 3/4" Dia. Bore
2	717-104	1	Driven Unit, 5/8" Dia. Bore
3	754-100	1	Drive Belt, "V" Type
4	736-115	1	Washer, 3/8 I.D.
5	750-101	1	Spacer 1" O.D. x 3/4 I.D. x 9/16 Lg.
6	710-113	1	Bolt, Hex Hd. 3/8 N.F. x 2 Lg. Whiz Lok

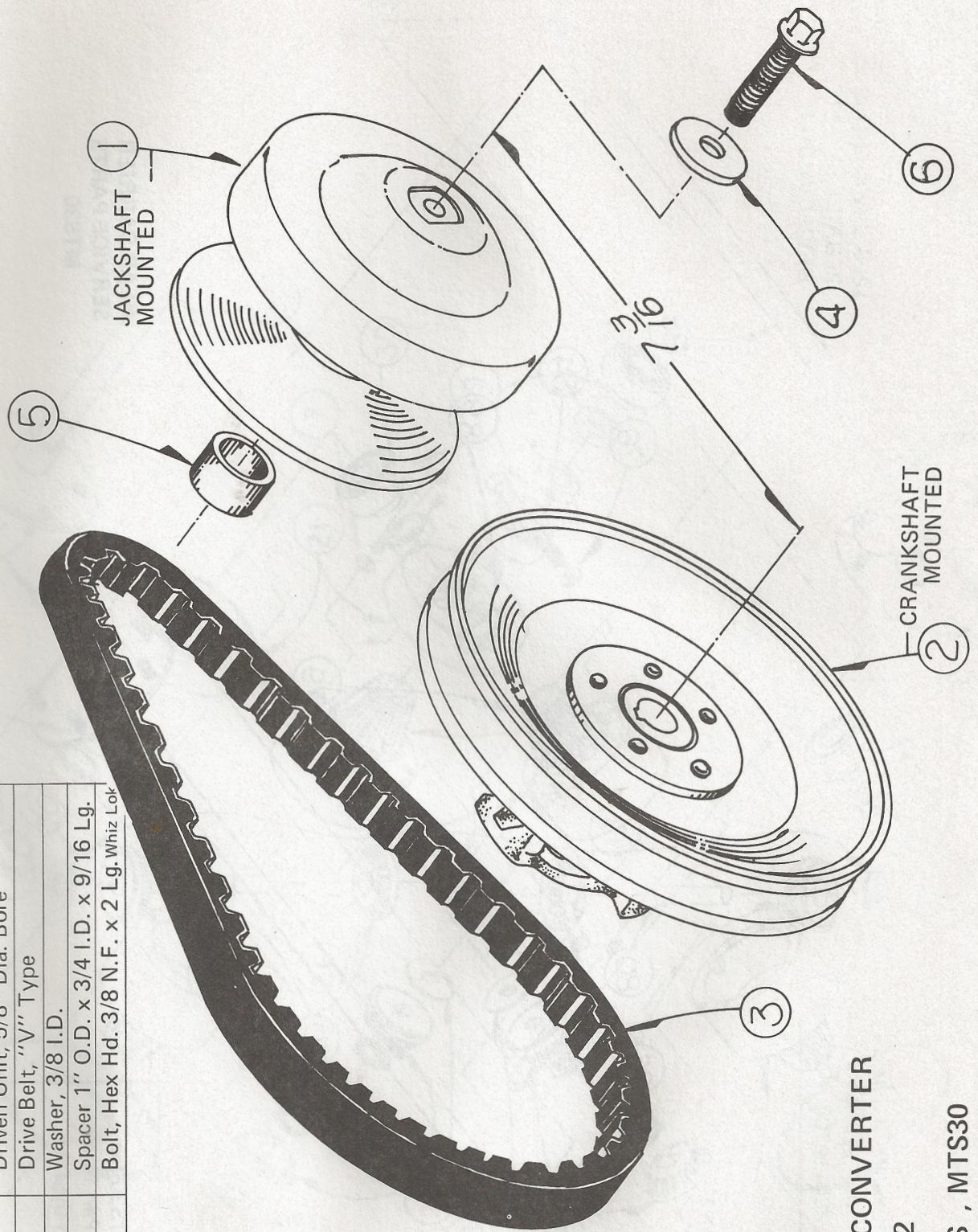

TC87 TORQUE CONVERTER

717-102

SERVICE PARTS , MTS30

REAR CARRIER  
SERVICE PARTS  
MTS30

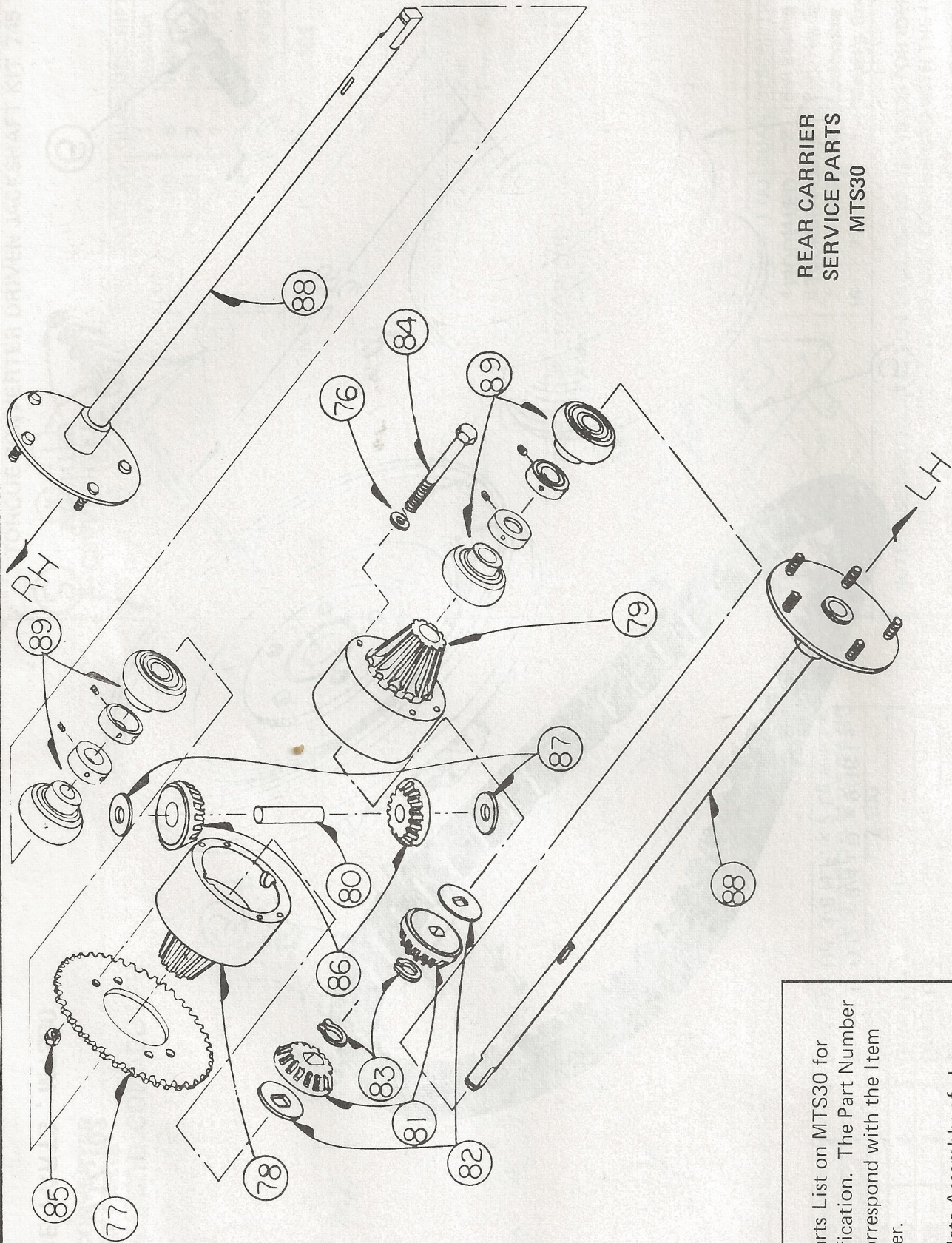

NOTE: Use Parts List on MTS30 for identification. The Part Number will correspond with the Item Number.

NOTE: Complete Assembly of above parts, 760-101.

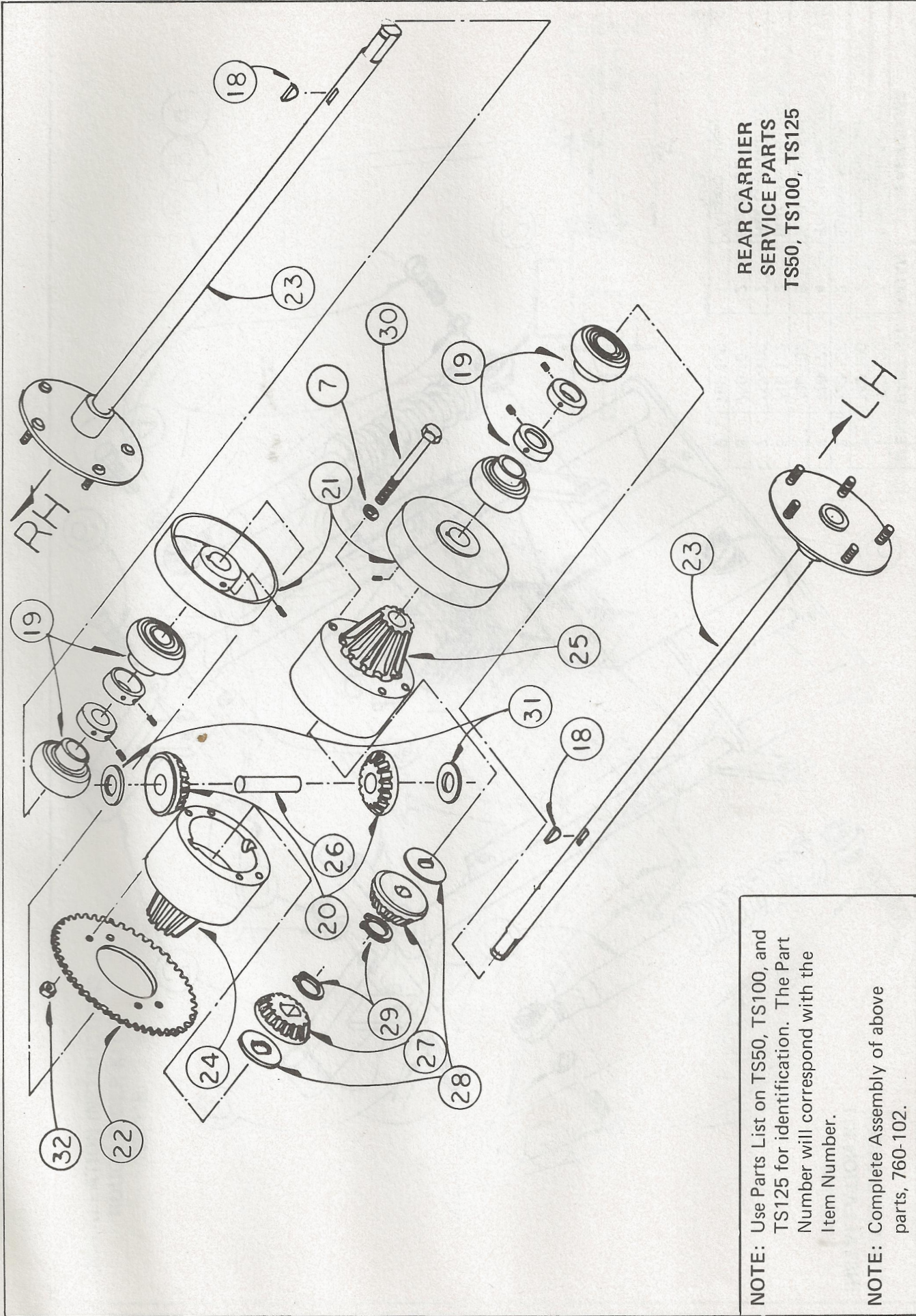

REAR CARRIER  
SERVICE PARTS  
TS50, TS100, TS125

NOTE: Use Parts List on TS50, TS100, and TS125 for identification. The Part Number will correspond with the Item Number.

NOTE: Complete Assembly of above parts, 760-102.

**FORK AND SHOCK  
INSTALLATION KIT  
760-114**

ITEM	PART NO.	QUAN.	PART NAME
1	733-120	1	Fork Weld Ass'y.
2	749-106	2	Shock Absorber
3	733-128	2	Spindle Mounts
4	710-122	4	Bolt, Hex Hd., 3/8 N.F. x 1 1/2
5	736-102	6	Washer, 3/8 SAE
6	710-102	2	Bolt, Hex Hd., 3/8 N.F. x 2
7	712-100	2	Hex Lock Nut 3/8 N.F.
8	750-107	2	Bolt Bushing
9	759-100	1	"Alsport" Decal

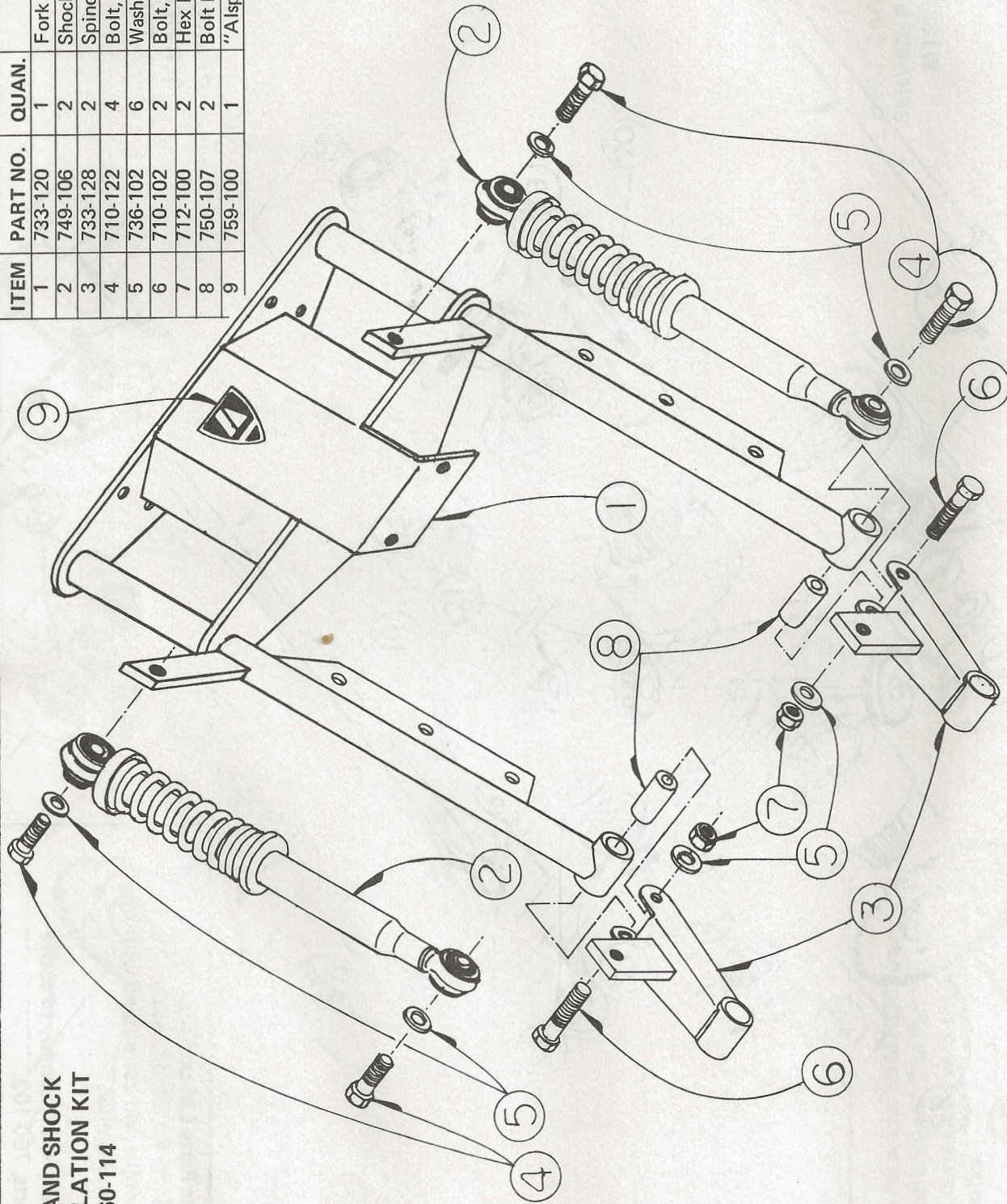

INSTALLATION INSTRUCTIONS  
ROUGH RIDER KIT  
760-118

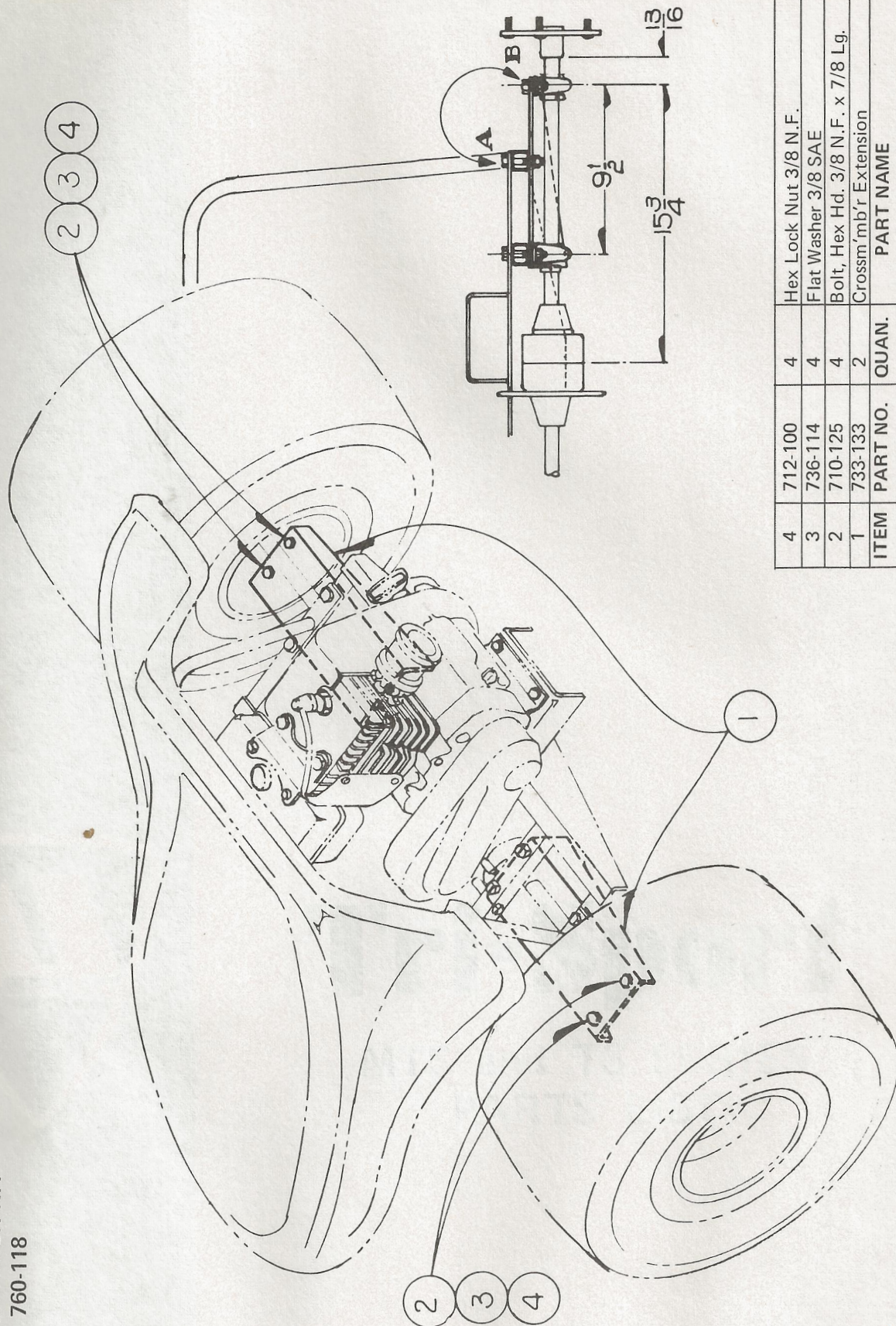

4	712-100	4	Hex Lock Nut 3/8 N.F.
3	736-114	4	Flat Washer 3/8 SAE
2	710-125	4	Bolt, Hex Hd. 3/8 N.F. x 7/8 Lg.
1	733-133	2	Crossm'br Extension
ITEM	PART NO.	QUAN.	PART NAME

**Alsport<sup>®</sup> Inc.**