

Pedal Interface II

Cruise control, speed limitation and speed control.



www.siemensvdo.com

Product Manual Pedal Interface II

Product Manual Pedal Interface II

Overview of Chapter

Topic	Chapter
Function description	1
Installation instructions	2
Configurations manager	3
Specifications	4
Scope of delivery	5
Type approvals	6
Data sheets	7

This documentation comes under the copyright of the Siemens VDO Trading GmbH.
It cannot be copied without previous written permission by the Siemens VDO Trading GmbH nor used in contradiction to their privileged interests.

Product-Manual Pedal Interface II

1. Function Description

Contents

1.1	Introduction	2
1.2	Versions	2
1.2.1	<i>Pedal Interface II Standard</i>	2
1.2.2	<i>Pedal Interface II Enhanced</i>	2
1.2.3	<i>Pedal Interface II Premium</i>	2
1.2.4	<i>Function Overview</i>	3
1.3	Functional Range	4
1.3.1	<i>Maximum Road Speed Limitation (v-max)</i>	4
1.3.2	<i>Variable Road Speed Limitation (v-var)</i>	4
1.3.3	<i>Road Speed Control (Cruise Control)</i>	4
1.3.4	<i>Additional Road Speed Limitation</i>	4
1.3.5	<i>Maximum Engine Speed Limitation</i>	5
1.3.6	<i>Variable Engine Speed Control</i>	5
1.3.7	<i>Fixed Engine Speed Control</i>	5
1.3.8	<i>Fuel Limitation</i>	6
1.3.9	<i>Status Outputs</i>	6
1.4	Installation Overview	6
1.5	Interface Description Accelerator Pedal Unit	7

Product-Manual Pedal Interface II

1. Function Description

1.1 Introduction

The Pedal Interface II is available in three different versions with two different Interface hardware specifications.

- 3 analogue channel (type 1)
- 2 analogue channel with idle validation and kick down switch (type 2)

The VDO Pedal Interface II consists of an electronic controller which is mounted between the accelerator pedal unit and the engine control unit (ECU). The output signal of the accelerator pedal is modified to control the road and engine speed. Therefore a modification in the electronics or software of the standard engine control systems can be avoided.

The VDO Pedal Interface II should only be installed to vehicles which have been approved and tested by Siemens VDO Trading.

1.2 Versions

1.2.1 *Pedal Interface II Standard*

- Cruise Control Function and Variable Speed Limitation -

Using one of the 3 cruise control stalk options any speed between 30 km/h and 200 km/h can be set. The speed set will then be maintained without actuation of the accelerator pedal. In addition a maximum road speed can be set with the control stalk, which cannot be overridden by the accelerator pedal.

1.2.2 *Pedal Interface II Enhanced*

- Cruise Control Function, Road and Engine Speed Limitation

In addition to the Standard version, this version offers a maximum speed limitation programmed using the configuration software manager which cannot be adjusted by the user. This function fulfils the EU directive 92/6 for vehicles > 3,5t (road speed limiter). Other functions include additional speed limits activated by status inputs and a maximum engine speed limitation, which leads to fuel savings and a reduction of engine wear.

1.2.3 *Pedal Interface II Premium*

- Cruise Control function, Road Speed Limitation, Engine Speed Limitation and Engine Speed Control

Along side the features of the Standard and Enhanced versions the Pedal Interface II Premium version enables engine speed control. The engine speed can be controlled using several options: cable-remote control, the cruise control stalk or status inputs. The engine speed can be adjusted to a pre-selected values programmed within the configuration manager.

The status inputs can also be used for a fuel limit function. This allows the accelerator pedal output signal to be limited to a preset % programmed using the configuration manager from 0% to 100%. It is possible to override the position limit with the cruise control function.

Product-Manual Pedal Interface II

1. Function Description

1.2.4 Function Overview

Version / Function	Standard	Enhanced	Premium
Cruise Control	X	X	X
Max. V*-limitation		X	X
Var. V*-limitation	X	X	X
Add. V*-limitation		X	X
Engine speed limitation		X	X
Fixed engine speed control			X
Var. engine speed control			X
Fuel limitation			X
2 Status Outputs	Cruise Control : on Limitation: on	Programmable	Programmable

*V = Road Speed

Product-Manual Pedal Interface II

1. Function Description

1.3 Functional Range

1.3.1 *Maximum Road Speed Limitation (v-max)*

The maximum road speed limitation is pre-programmed in the electronic controller of the Pedal Interface II and determines the maximum speed of the vehicle. This speed cannot be adjusted by the user.

Range: 1-200 km/h or 1-124 Mph
Speed signal
Wire no.22 (pin 4): Square Wave signal directly from speed sensor or pulse width modulated (PWM) speed signal from tachograph (C3/B7).
Input frequency: min. 7.63 Hz, max. 5kHz, Adjustable between 460 – 300.000 pulses / km.
Low voltage < 1,6V, High voltage > 6V to 32V

Control function; the Fault Throttle Limit is programmable from 0%-100% and the fault time from 0 to 60 seconds. The fault throttle limit activates with a breakdown of v-signal while the accelerator pedal position lies above the programmable fault throttle limit for longer then the adjustable fault time. The timer can only be reset with the return of the speed signal. Once in the fault throttle mode a 100% throttle can only be achieved by turning the ignition off for a minimum of 10 seconds.

1.3.2 *Variable Road Speed Limitation (v-var)*

With the cruise control lever the driver can set and adjust any speed limit between 30 km/h and the programmable maximum speed (e.g. within city areas or within built-up areas). This set speed limit cannot be overridden with the accelerator pedal. The speed limitation can be switched off with the control lever or ignition off.

1.3.3 *Road Speed Control (Cruise Control)*

With the cruise control lever the driver can set and adjust any speed between 30 km/h and the programmable maximum speed. This speed is controlled by the Pedal Interface II independently of the load states of the vehicle. Therefore, the driver does not need to press the accelerator pedal. The set speed can be overridden by the vehicle pedal up to the programmed maximum speed. The cruise control will be disengaged by the cruise control lever, the brake or the clutch. Using the Memo-Function the speed set before switching off, can be resumed.

1.3.4 *Additional Road Speed Limitation*

Range: 1 km/h – additional to maximum road speed limitation
Speed signal: see 1.3.1

A Maximum of 7 additional road speed limits can be activated via status inputs. The additional speed limits should be used for voluntary speed limiter applications. For the regulation installations, the maximum road speed limitation is used.

Product-Manual Pedal Interface II

1. Function Description

1.3.5 *Maximum Engine Speed Limitation*

A maximum engine speed can be set via the configuration manager this cannot be changed by the user.

Range:	Idle speed – 20,000 rpm
Engine Speed Signal wire no. 21 (Input 3):	Square Wave signal or sine wave signal (AC coupled) Frequency: min. 7,63Hz, max. 5 KHz, adjustable. Minimum 0.8v pp (peak to peak), maximum 50v pp (peak to peak)

This input can also be used as a road speed input for vehicles with low voltage road speed signals.

1.3.6 *Variable Engine Speed Control*

Range :	Idle Speed – 20,000 rpm Minimum and maximum engine speed, programmable
Engine speed signal:	see 1.3.5

With the cruise control stalk, hand set (two wire data cable) or external switches (cruise control stalk inputs) a variable engine speed control can be realised. Using the engine control options the variable engine speed can be switched on or off and modified within the programmed range.

The conditions for switching on and off the engine speed control can be programmed dependently of the minimum and maximum engine speed parameters using the status inputs. For the disengaging of engine speed control the status input 3 (marked with disengage PTO wire no. 29, Input 11) is automatically assigned.

Because of safety reasons when using the cruise control stalk (LED or Flexible) for this function; there are two inputs which have to be used for PTO disengage. In addition to Status – Input 3, Status - Input 4 (wire no. 28, Input 10) has to be connected.

Note:

The conditions required to enable the rpm control functionality has to be agreed with the vehicle or body manufacturer. Any installation involving engine speed control has to be wired taking into account any safety critical functions. It is important that the rpm control cannot be activated while the vehicle is in gear or being driven.

1.3.7 *Fixed Engine Speed Control*

Range :	Idle Speed – 20,000 rpm
Engine speed signal:	see 1.3.5

Via the status inputs a maximum of 6 fixed engine speeds can be controlled with one status input being used for PTO disengage. Each engine speed can individually be adjusted with its own control parameter (P+I: rpm gain and integration time). The requirements for switching on and off are the same as for the variable engine speed control (see 1.3.6).

Note:

The conditions required to enable the rpm control functionality has to be agreed with the vehicle or body manufacturer. Any installation involving engine speed control has to be wired taking into account any safety critical functions. It is important that the rpm control cannot be activated while the vehicle is in gear or being driven.

Product-Manual Pedal Interface II

1. Function Description

1.3.8 Fuel Limitation

Range:0-100% (0% = full limited, 100 % = not limited).

For the limitation of the output signal of the accelerator pedal unit a maximum of 7 position limitations can be activated via status inputs. It is possible to override the position limit with the cruise control function.

1.3.9 Status Outputs

Maximum current 150 mA

The control electronic has 2 programmable status outputs which are activated at the following functions:

- Individually programmable road speed
- Individually programmable engine speed
- Variable engine speed control switched on
- Fixed engine speed control switched on (status output switches at freely selectable engine speed)
- Variable speed limit switched on
- Road Speed Control (cruise control) switched on

1.4 Installation Overview

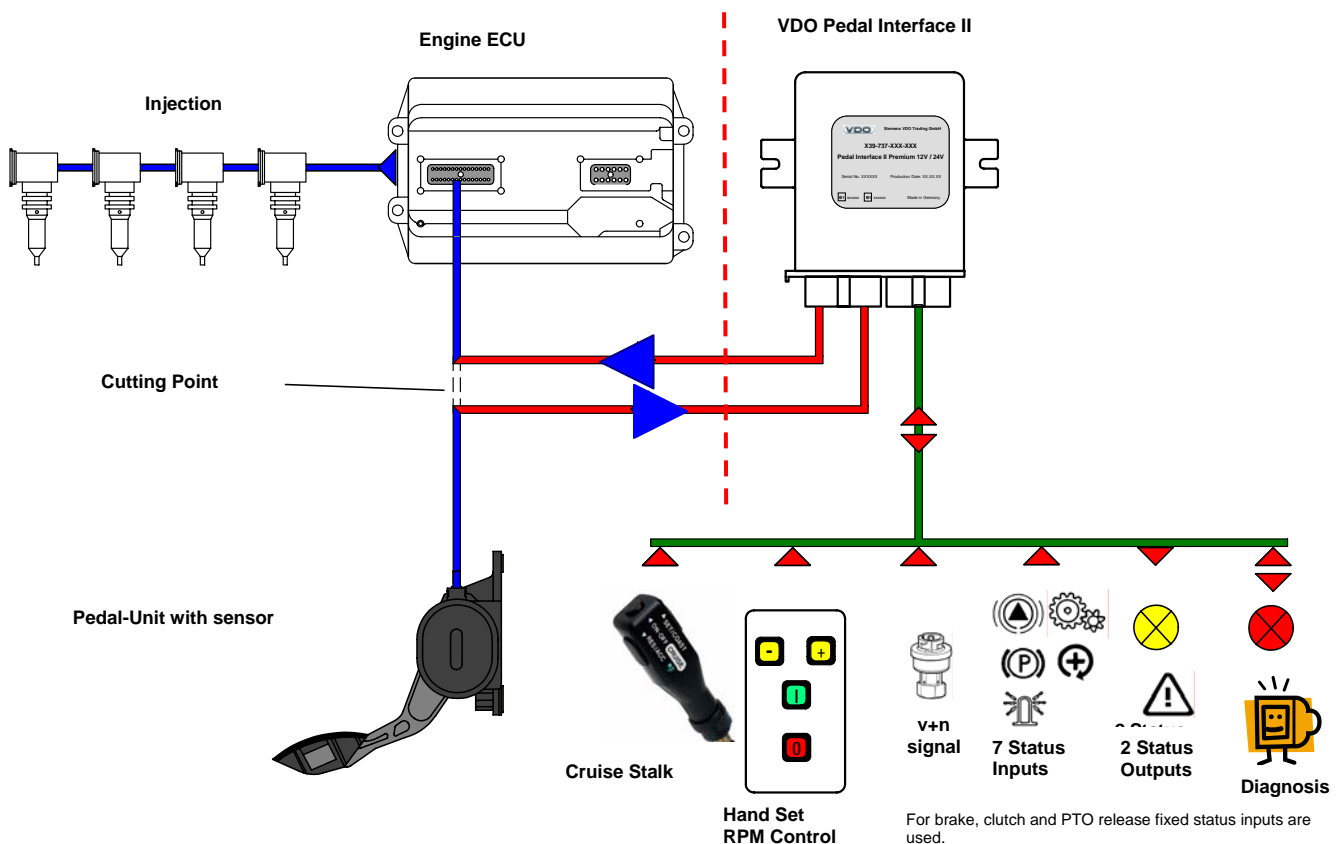

The vehicle accelerator pedal is displayed on the left side; the engine control unit and the fuel injection are part of the existing vehicle system. The Pedal Interface II with all inputs and outputs, displayed at the right side, are installed additionally into the vehicle and connected via the pre-manufactured wiring harness.

Product-Manual Pedal Interface II

1. Function Description

1.5 Interface Description Accelerator Pedal Unit

The pedal units or pedal sensors can vary from one vehicle to the next.

The VDO Pedal Interface II can be used with analogue signal pedal units. There are two different types available Type 1 and Type 2, each type has three different versions (functional range):

- Type 1: Pedal interface with max. 3 analogue signals without idle switch.
- Type 2: Pedal interface with max. 2 analogue signals and one idle switch as well as one kickdown switch.

The programming of the vehicle specific parameters is done with a "master file download" in the electronic controller via the Siemens VDO Configuration Manager.

The master file is created for a specific vehicle pedal unit or pedal sensors with tolerances incorporated. The tolerances are included to allow for any differences between each individual pedal of the same vehicle type.

The following diagram displays an example of a pedal unit with an analogue output and an idle switch.

Example:

Vref = 5 V

Idle 5 % +/- 2 %

Full Load 85 % +/- 5 %

Idle Validation Switch 15 % +/- 2%

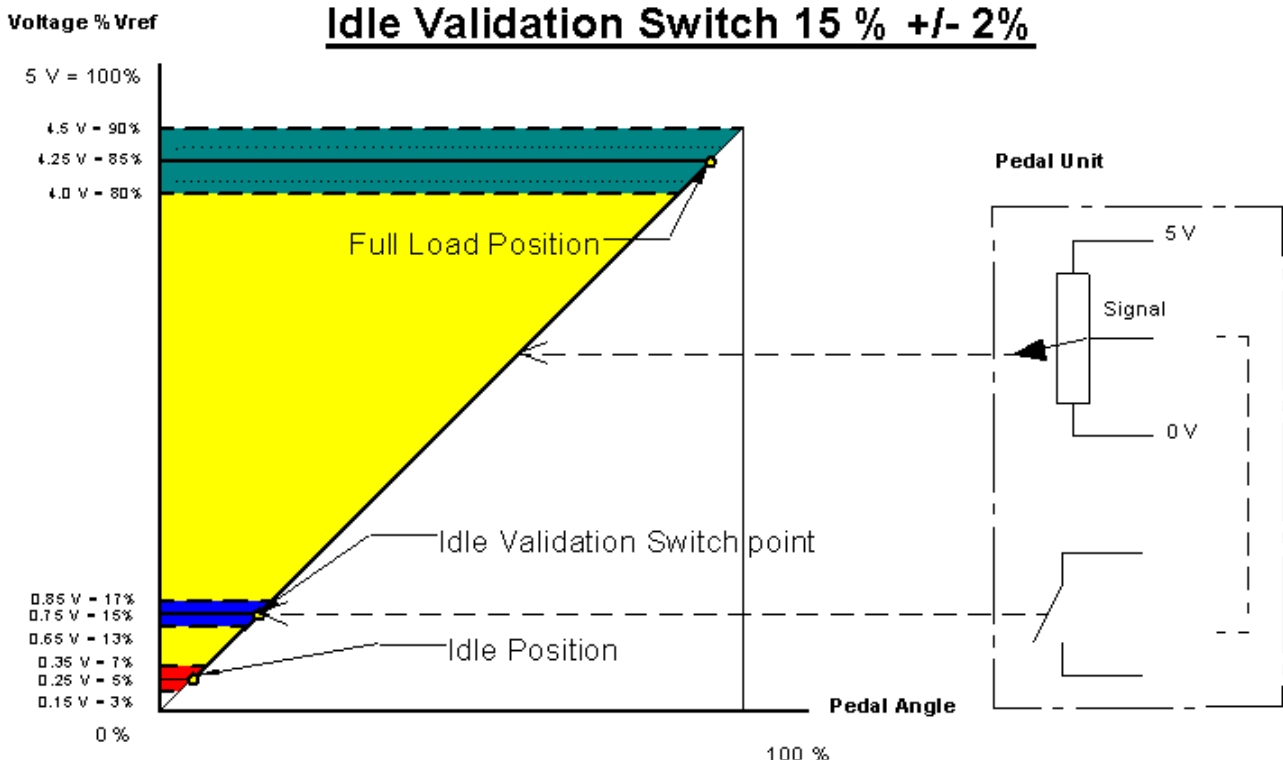

Product Manual Pedal Interface II

2. Installation Instructions

Contents

2.1 Safety Instruction	2
2.2 Preparation for Installation	4
2.3 Installation Steps	4
2.3.1 Installation of the Pedal Interface II Control Unit	4
2.3.2 Electrical Connection	4
2.3.3 Overview Table of In- and Outputs and Function Description (15-pole connector)	5
2.3.4 Electrical Connection of Pedal Interface	7
2.3.5 Electrical Connection of Voltage Supply	8
2.4 Pedal adjustment	9
2.5 Completion of Installation	13
2.6 Electrical Connection Diagram	14
2.7 Mounting Flow-Chart Pedal Interface II	15

Product Manual Pedal Interface II

2. Installation Instructions

2.1 Safety Instruction

- The product was developed, manufactured and tested considering the basic safety requirements of the EU guidelines and the accepted best available technology. The product is only for the use in grounded vehicles (exception: motorbikes) or stationary machines.

Before installation, attention should be paid to:

- Please check with Siemens VDO documentation as to whether the vehicle application has been released by Siemens VDO.
- Only to be installed by authorized trained personnel.
- Only to be installed by qualified auto electricians.
- Note data from volatile memories.
- Remove the key from the ignition. Then disconnect the negative terminal of the battery (also from additional batteries). When disconnecting the negative terminal from the battery, all volatile electronic memories may lose their input values.
- Not disconnecting the negative terminal of the battery can cause short circuits in the main power supply. These circuits may produce cable fires, battery explosions and damage to other electronic systems.
- Familiarise yourself with the vehicle type and vehicle-specific characteristics as e.g. position of fuel, hydraulic, air pressure and electrical lines before installation.
- Install the product in accordance with regulations, do not modify or tamper with the unit. Should the product be installed not in accordance to regulations, modified or tampered with may result in damage to persons, property or environment, or may affect safety.

Before Installation, attention should be paid to:

- Safety instructions of the vehicle, engine or tooling manufacturers!
- Select mounting position in such a way, that the product and its components:
 - do not affect or impede functions of the vehicle or the stationary machine.
 - cannot be damaged by functions of the vehicle or the stationary machine.
 - do not impair the viewing zone of the driver.
 - are not positioned in the head-impact zone of the driver or passenger
 - are not positioned in the mechanical and electrical airbag zone.
 - have space behind the drill-hole or the mounting hole.
 - do not drill holes into supporting and stabilizing braces or bars!

After installation, attention should be paid to:

- Connect ground cable to negative terminal of battery.
- Re-input programme values of volatile memories.
- Check all vehicle functions.
- Note data from volatile memories.

Product Manual Pedal Interface II

2. Installation Instructions

2.1 Safety instructions

For measuring voltages and currents in the vehicle only use a designated multimeter or diode control lamp. The use of conventional control lamps can cause damage to control units or other electronic systems.

Special Case:

Act with caution if essential work is required with the engine running. Wear appropriate work clothes, because there is the danger of injuries such as bruises or burns. Long hair should be tied back and a cap worn.

Do not smoke!

No open fire or light!

Electrical Connection

Connect the cables according to the electrical connection diagram. Incorrect connections may lead to short circuits!

Safety instructions:

- Danger of short circuit caused by incorrect connections or damaged cables! Therefore, all connections to the voltage supply have to either be smoothly soldered or provided with a solderable butt joint and adequately isolated. Pay special attention to correct ground connections! Cable ends not used must be isolated!
- Pay attention to cross section of cables! A reduction of the cable cross section leads to an increased current density. This may lead to an increased heat within the corresponding cable section!
- Stripping of cable insulation should only be carried out with an appropriate stripping tool. Adjust the stripping tool in such a way that no conductor is damaged or separated!
- Only crimp connections with an appropriate crimping tool. When running cables only use existing cable channels and cable lines, do not lay the cables parallel to ignition cables or high current cables! Fix the cables with binders or adhesive tape!
- Pay attention that the cables cannot be damaged!
- If the cables are run through panel holes, protect them with grommets or similar parts.

Do not smoke!

No open fire or light!

Product Manual Pedal Interface II

2. Installation Instructions

2.2 Preparation for Installation

- Before starting the installation make sure that the vehicle application is released and documented by Siemens VDO Trading.
- Please read carefully the safety instructions (Pt. 2.6.) and the below mentioned basic installation steps before you start an installation based on the vehicle-specific mounting instruction.
- Check that after switching on the ignition and starting the engine, there is no electronic engine control fault light on and no current fault exists (read the operating instruction of the vehicle)

2.3 Installation Steps

- Switch off ignition and remove the key. During installation the ignition must not be switched on. This will ensure that the electronic engine control does not generate any faults.

2.3.1 Installation of the Pedal Interface II Control Unit

The control unit may only be mounted inside the vehicle. Fix the control unit with the two self-tapping screws 4.8x13 provided in the installation kit. Pay attention to the fact, that the cable length of the wiring harness between the Pedal Interface II control unit and the splitting point at the pedal is maximum 1500mm. The connector of the Pedal Interface II control unit must point downwards.

2.3.2 Electrical Connection

Complete the electrical connections according to the vehicle-specific mounting instruction. The connection of the speed signal on vehicles that have to be equipped according to EU directive 92/6 has to be accomplished in such a way, that any tampering is traceable. Therefore, do not cut the circuit between Pedal Interface and connection point. In case a cut is necessary use a sealing-capable connector with sealing wire and lead seal.

Should the vehicle already be installed with a tachograph the connection of the speed signal can be taken from the PWM signal output of the tachograph. In this case the input signal Tacho/PWM is chosen as pulse source via the configuration software. An adjustment of the distance pulses is not necessary with a correctly calibrated tachograph system. If the speed signal is taken from the circuit of the speed sensor instead of the tachograph, the distance pulse has to be adjusted via the configuration software (see point 3.3.1 of the configuration software).

Product Manual Pedal Interface II

2. Installation Instructions

Connection example PWM signal at tachograph

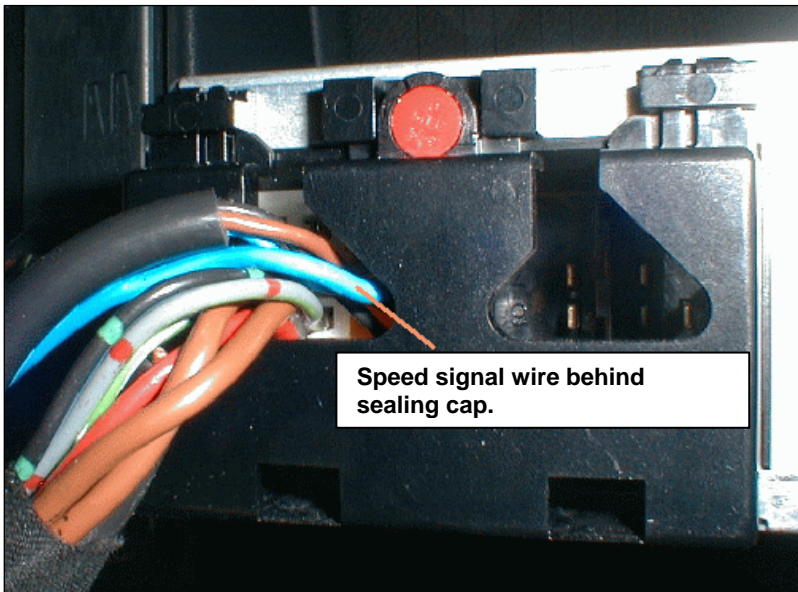

2.3.3 Overview Table of In- and Outputs and Function Description (15-pole connector)

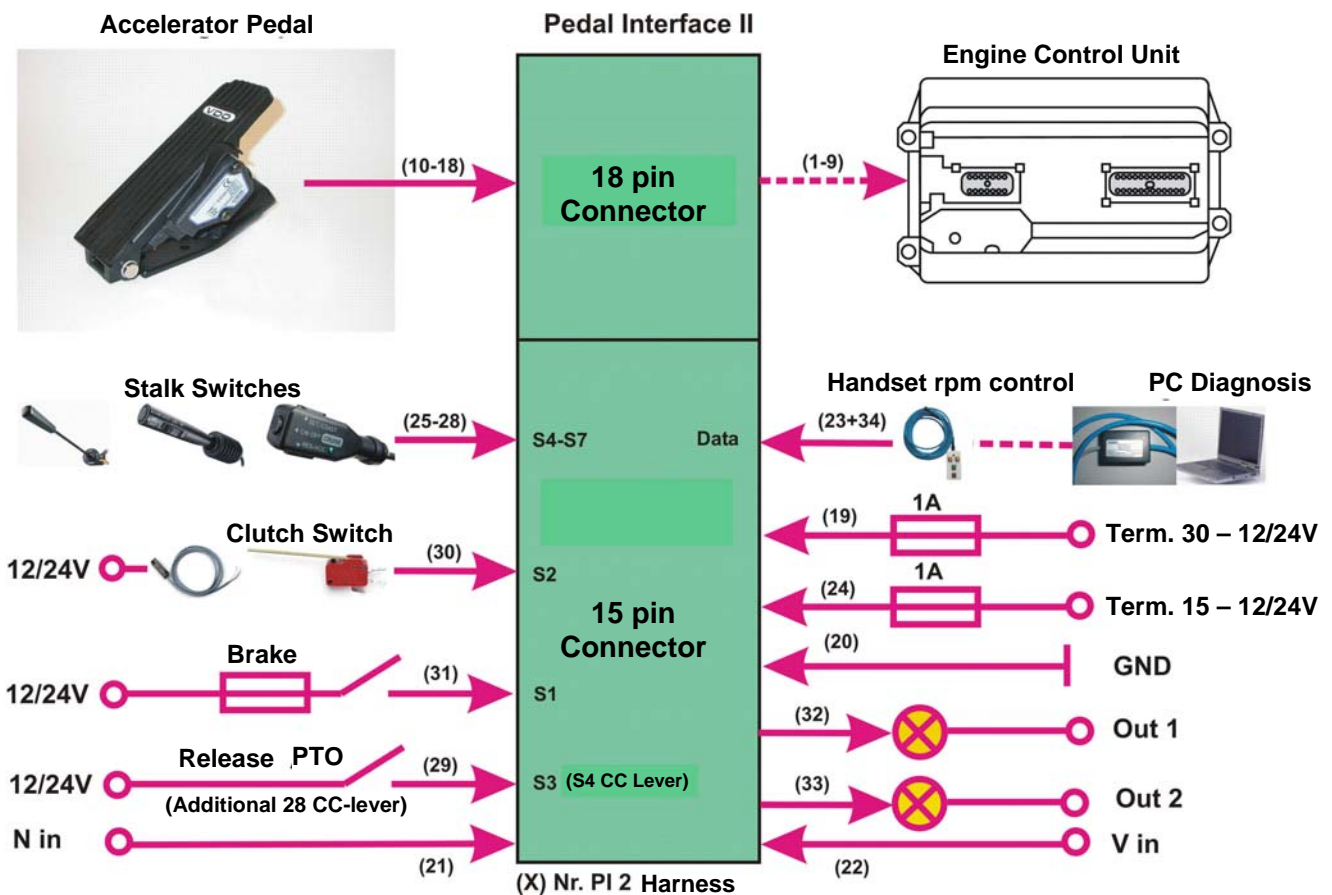

Product Manual Pedal Interface II

2. Installation Instructions

Designation	Cable Number	PIN ECU	Function
			NO = Switch, Normally Open NC = Switch, Normally Closed
Terminal 30	19	1	1A fuse, battery +
Vehicle ground	20/34	2	Battery -
RPM signal input (also possible to use for road speed)	21	3	Frequency input for square wave or <u>sine signal</u> for low voltage <u>min. > 0.8 V ptp. max. < 50V ptp.</u> If input 21 is used as v-input, input 22 automatically becomes the input for rotation speed.
Road speed input (also possible to use for engine speed)	22	4	Frequency input for square wave or PWM signal. Has to be used for Hall sender or tachograph PWM output (B7/C3).
Data Input and Output	23	5	Interface for dongle or hand - set for variable engine speed control.
Terminal 15	24	6	1 A fuse, ignition "on"
Status 7	25	7	<u>For use with cruise control:</u> Standard stalk → Memo Function (NO) LED/Flex stalk → cruise control switched on/off (NO) <u>Without cruise control:</u> Freely programmable via software (NO)
Status 6	26	8	<u>For use with cruise control:</u> Standard stalk → acceleration (NO) LED/Flex stalk → Memo/acceleration (NO) <u>Without cruise control:</u> Freely programmable via software (NO)
Status 5	27	9	<u>For use with cruise control:</u> Standard stalk → switch on cruise/ deceleration (NO) LED/Flex stalk → switch on cruise/ deceleration (NO) <u>Without cruise control:</u> Freely programmable via software (NO)
Status 4	28	10	<u>For use with cruise control:</u> Standard stalk → Off (NC) With use of LED/Flex stalk for variable engine speed control → Additionally, safety relevant second release for engine speed control (For safety reason should always be positive switching). (NO) Without cruise control freely programmable via software (NO)
Status 3	29	11	Designated as primary disengage for engine speed control (for safety reasons, should always be positive switching). (NO) <u>Without using rpm control:</u> Freely programmable via software. (NO)
Status 2	30	12	<u>For use with cruise control I:</u> Fix for clutch switch → only with mechanical transmission (Plus switching) NO/NC Without cruise control or vehicles with automatic transmission freely programmable via software
Status 1	31	13	<u>For use with cruise control:</u> Fix for brake light switch (positive switching) NO Without cruise control freely programmable via software
Output 1	32	14	Freely programmable via software (switches to ground) NO/NC
Output 2	33	15	Freely programmable via software (switches to ground) NO/NC

Product Manual Pedal Interface II

2. Installation Instructions

2.3.4 Electrical Connection of Pedal Interface

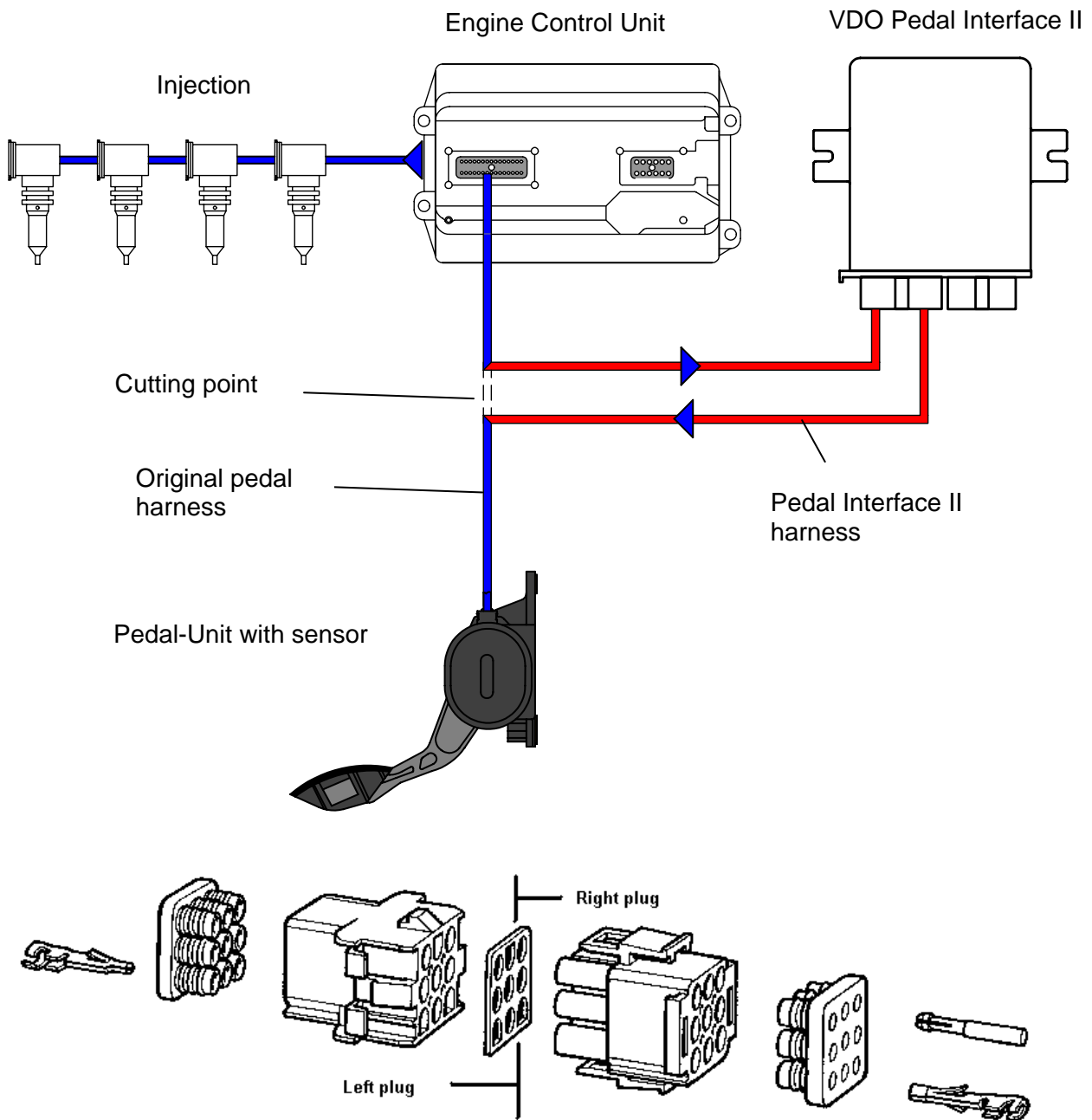

Left plug:

From Pedal to PI 2 and from VDO PI 2 to engine control unit.

Right plug:

From VDO PI 2 to pedal and from engine control unit to VDO PI 2.

- If all the connections are not used, the free wires have to be plugged into the free inputs from the connector to prevent short circuits. After completion of the electrical connection, plug the pedal connector to the VDO PI 2 control unit. The plug connection of the VDO PI 2 control electronic to the engine control unit has to remain detached until the programming of the pedal is finished to ensure no fault is passed to the vehicle engine control unit.

Product Manual Pedal Interface II

2. Installation Instructions

2.3.5 *Electrical Connection of Voltage Supply*

- The Pedal Interface II is connected to both terminal 30 and terminal 15 of the vehicle voltage supply. Both connections have to be fused with the 1A fuses, which are covered within scope of delivery. The final connection of terminal 15 will be done after the pedal adjustment with the configuration manager. The connections for Terminal 15, 30 and 31 should be carried out without the use of splice connectors or cutting connectors to guarantee a safe connection. If necessary soldering the contacts.
- Please note: The LED cruise control stalk is only for vehicles with 12 V power supply. If the LED stalk is connected to a 24 V system the stalk will be damaged.
- The ignition key has to be removed and ignition must be off. Pedal Interface should now be powered allowing connection to the configuration manager in order to program the VDO PI 2 control unit and to adjust the pedal.
- Connect the dongle to the wiring harness (2-pole connector) and your PC. Start the VDO PI 2 Configuration Manager, PI 2 control unit is now connected to the PC.

Product Manual Pedal Interface II

2. Installation Instructions

2.4 Pedal adjustment

Start the Configuration Manager and click "Next"



The below page will appear if the PI2 control unit has already been programmed.

To edit the existing parameters click "Next". To select a new vehicle click the "New" button.

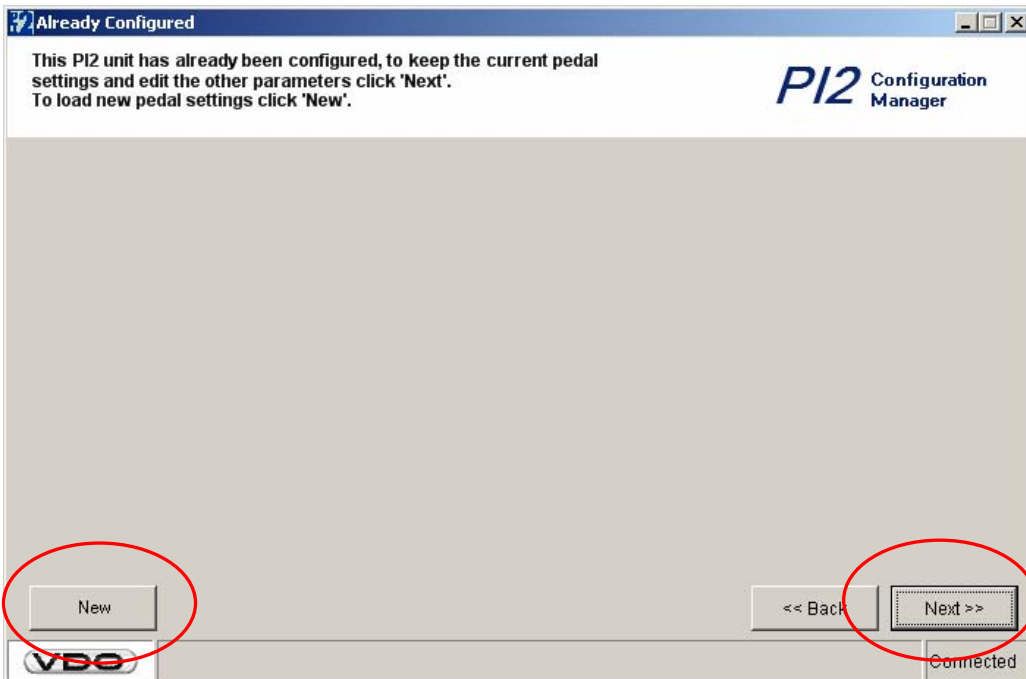

Product Manual Pedal Interface II

2. Installation Instructions

2.4 Pedal adjustment

The below page will appear if PI2 control unit has never been programmed or the New button was clicked on page shown above. Now choose the manufacturer and the model. Then press "Next".

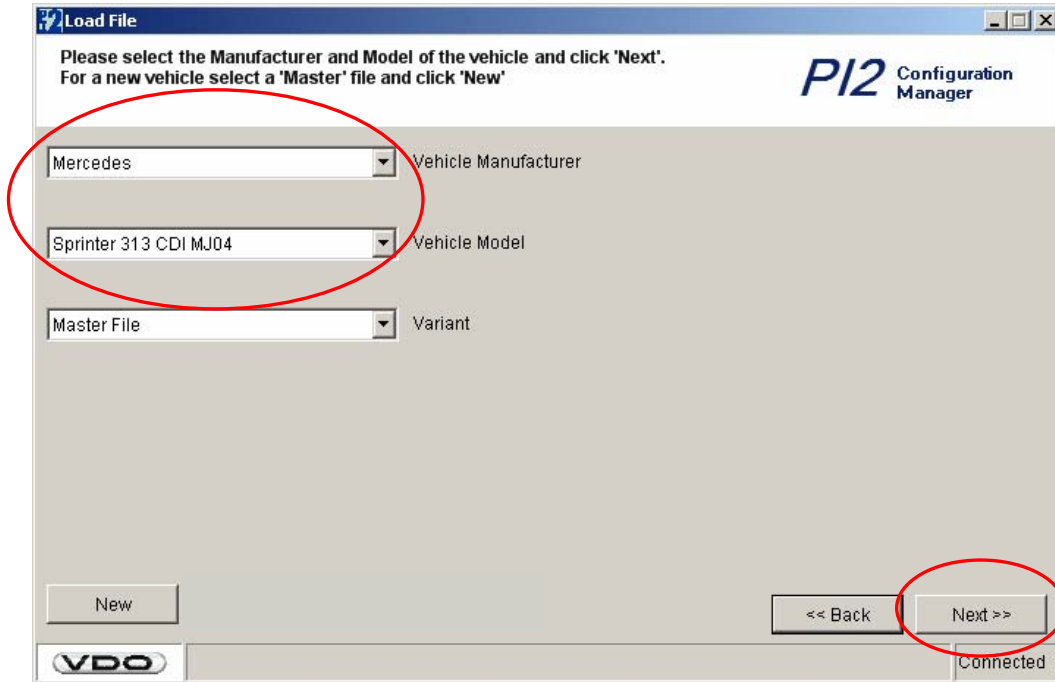

Follow the instructions from the page heading in order to set the throttle pedal and wait for the audible alarm signal. In cases where the bars are not green and you receive an error message, check if the correct vehicle has been selected and the electrical connections are correct.

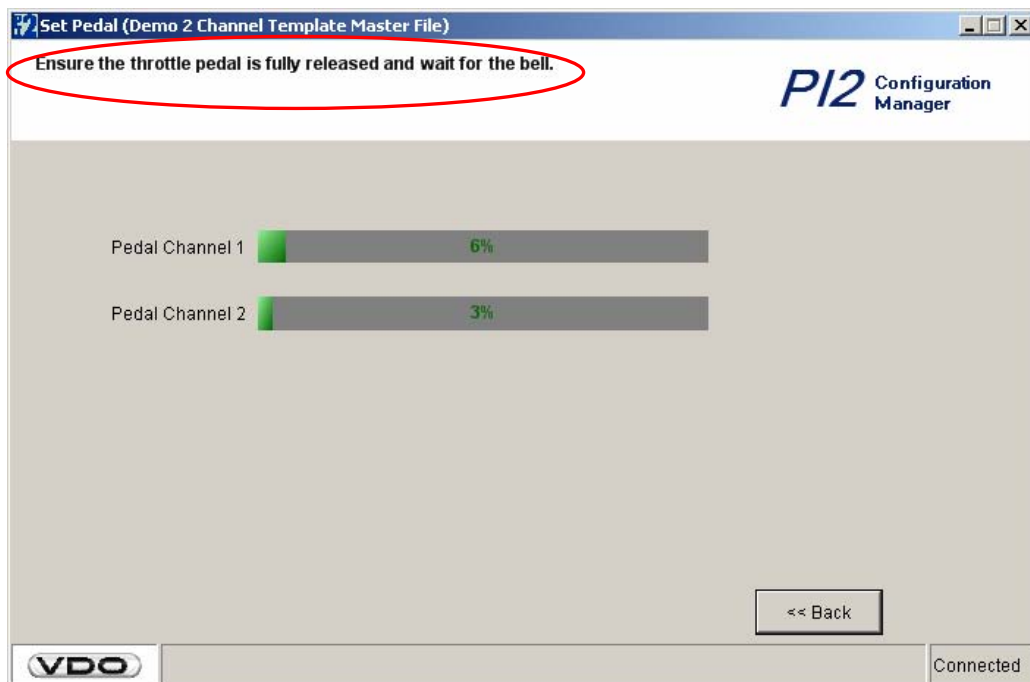

Product Manual Pedal Interface II

2. Installation Instructions

2.4 Pedal adjustment

Push the throttle down and hold in the full-throttle position until you hear the audible alarm or follow the instructions in the heading.

If the bars do not change to green and you receive an error message, check if the correct vehicle has been selected and the electrical connections are correct.

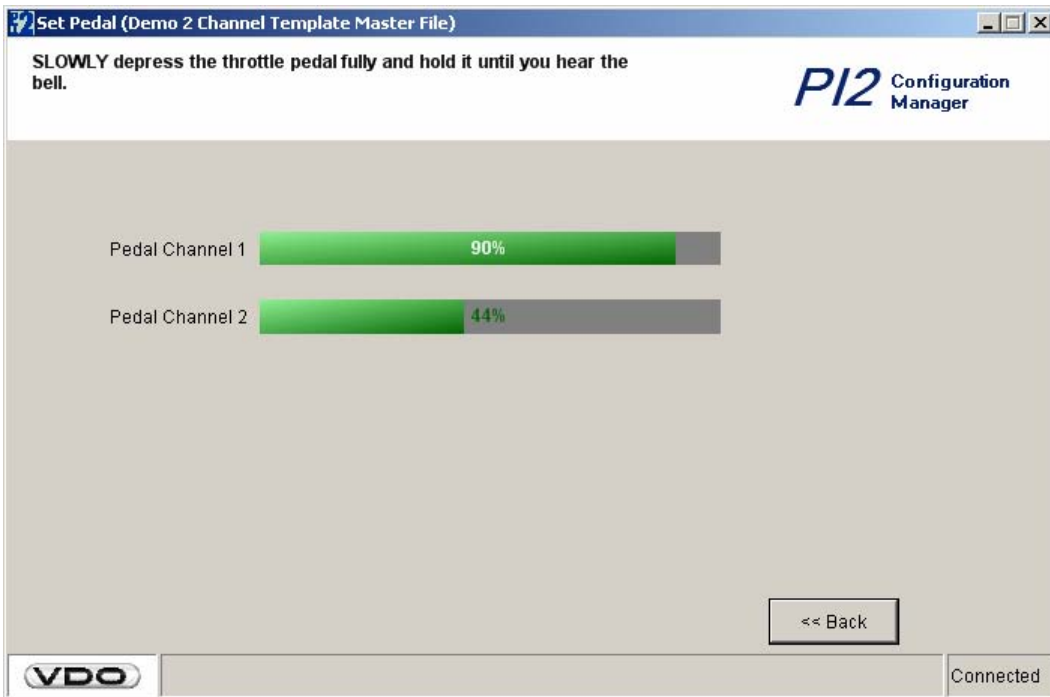

Wait until for the audible alarm or follow the instructions in the page heading. Slowly release the pedal. After a successful throttle pedal setting, the configuration manager will automatically down load new data and open the function select page.

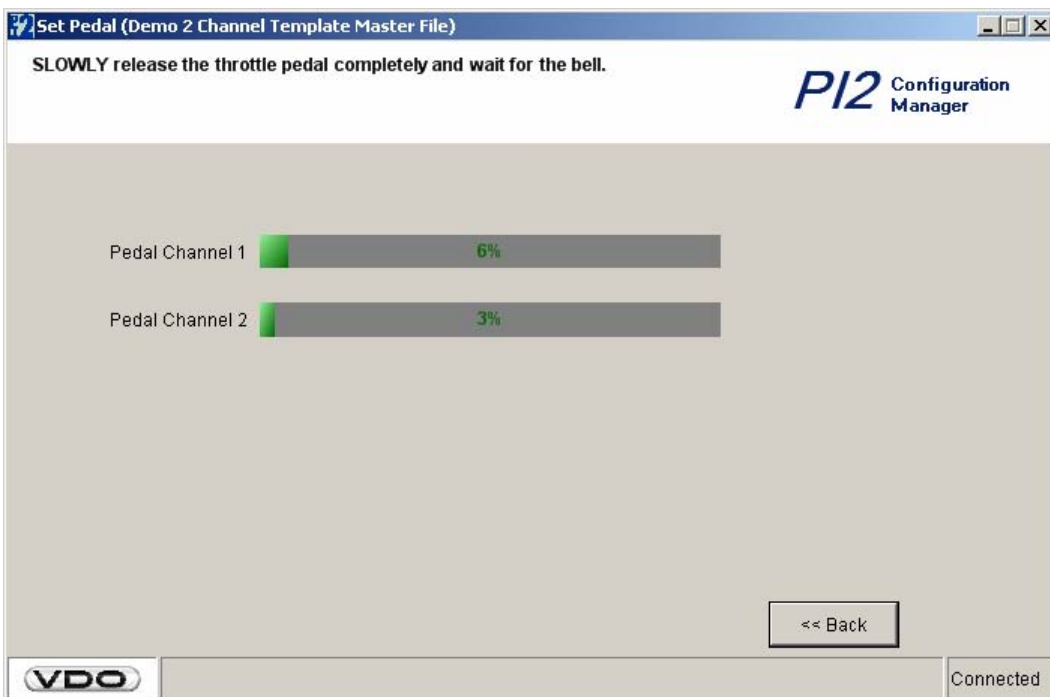

Product Manual Pedal Interface II

2. Installation Instructions

Now you can program individual parameters for the vehicle via the configuration manager.

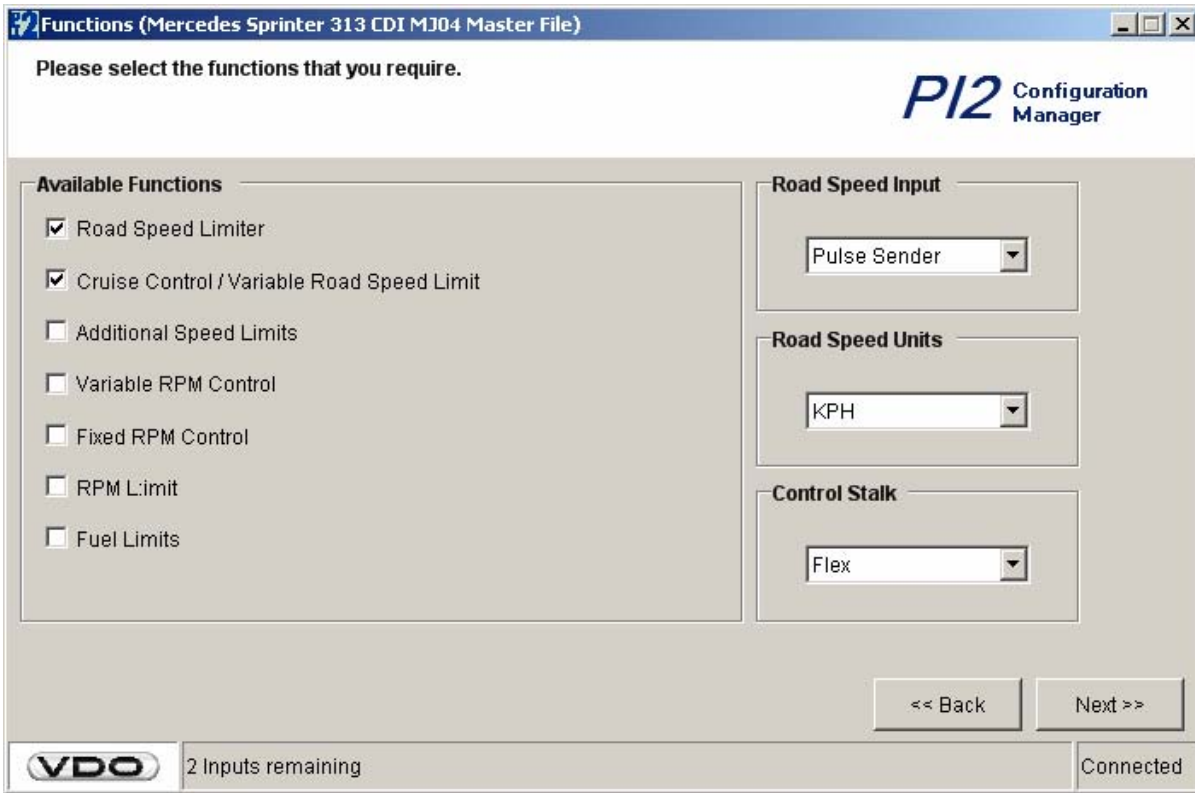

The description for programming the vehicle parameters can be read in:
Chapter 3.2: "Programming of vehicle-specific parameters".

Product Manual Pedal Interface II

2. Installation Instructions

2.5 Completion of Installation

Now complete the electrical connection for the Terminal15 and connect the plugs between the VDO Pedal Interface II control unit and vehicle engine control unit.

Seal the two plug connections on the pedal connection point.

Sealing lug connections

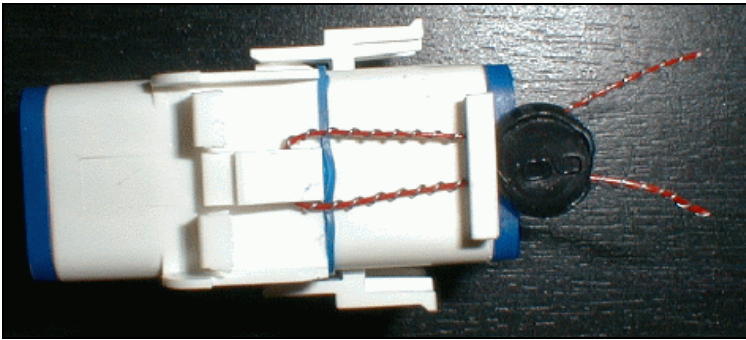

Sealed plug connections

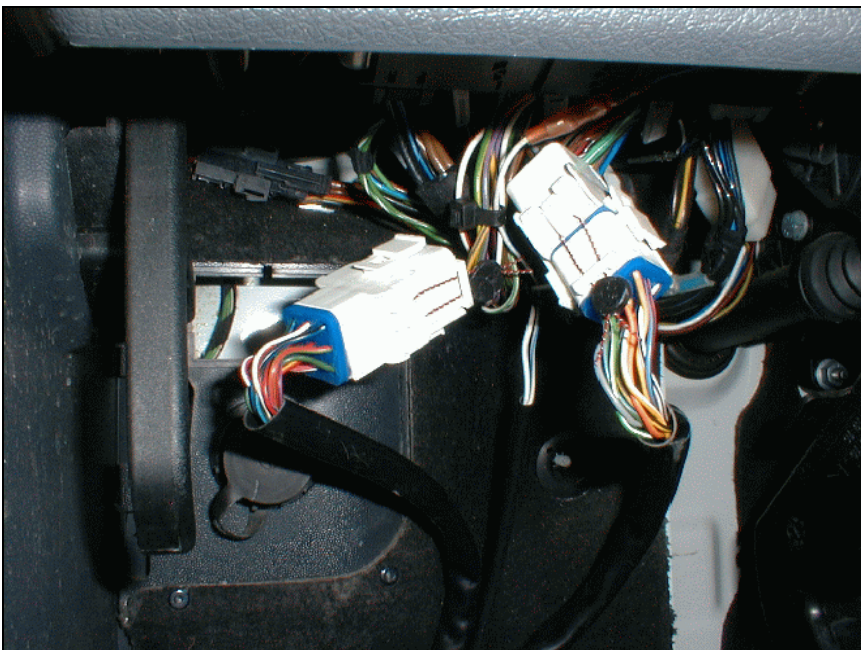

Check that after switching on the ignition and starting the engine, there is no electronic engine control fault light on and no current fault exists (read the operating instruction of the vehicle)

Product Manual Pedal Interface II

2. Installation Instructions

2.6 Electrical Connection Diagram

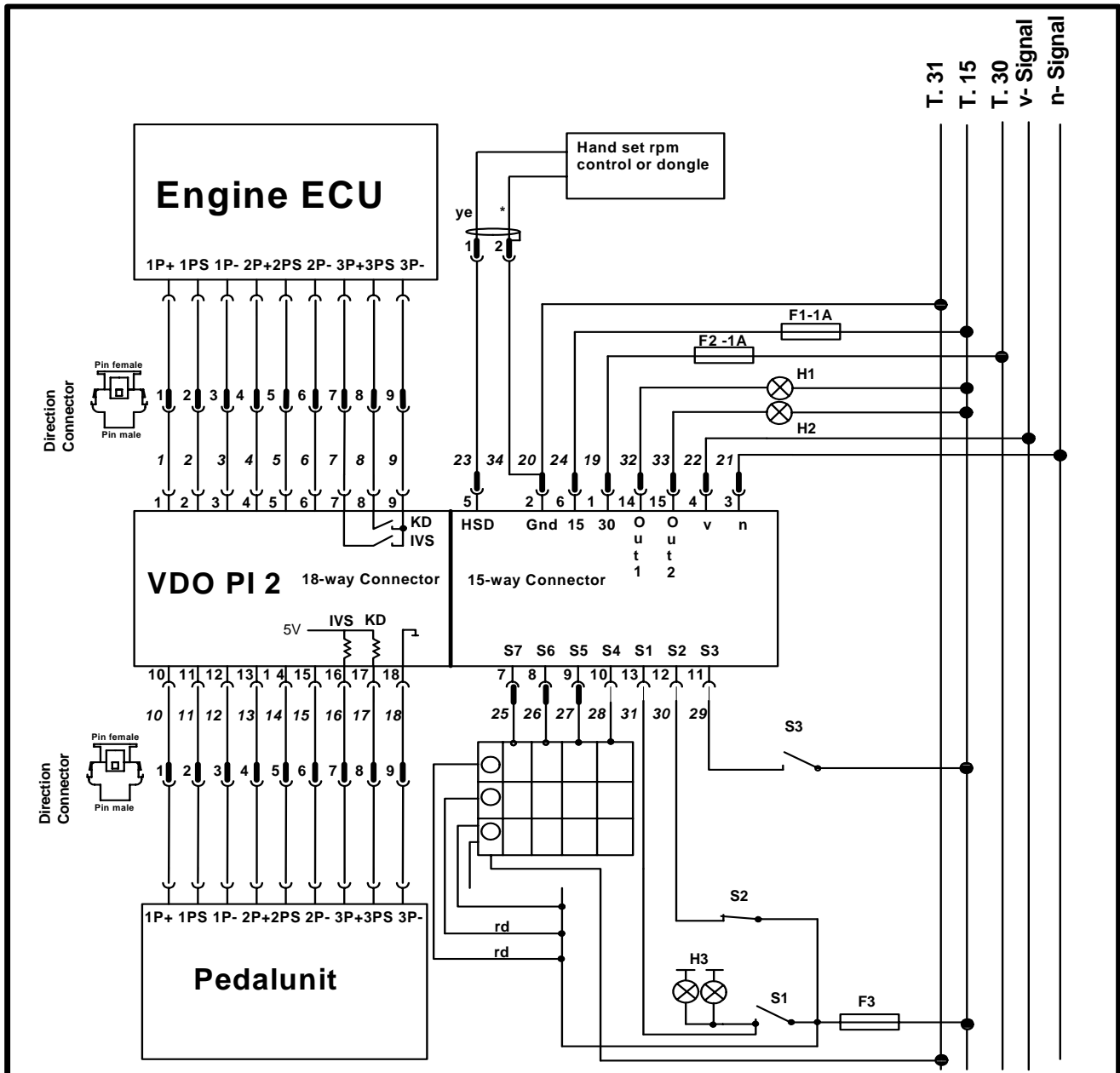

Legend: (S) = Standard (F) = Flex (L) = LED -Stalk

S1-S7: Statusinput 1-7

HSD: Data wire

Gnd: Vehicle ground

15: T.15

30: T.30

v: Road speed signal

IVS: Idle validation switch

n: RPM signal

Out1: Statusoutput 1

Out2: Statusoutput 2

F1: Fuse T.15 1A

F2: Fuse T.30 1A

F3: Break light fuse

KD: Kick-Down-Switch

*Transparency wire is ground wire and shield for data signals

S1: Break light switch

S2: Clutch switch (NC/NO)

S3: PTO release

H1: Statusoutput 1

H2: Statusoutput 2

H3: Brake lights

SIEMENS VDO
A u t o m o t i v e
VDO Pedal Interface II

Wiring Diagram

Product Manual Pedal Interface II

2. Installation Instructions

2.7 Mounting Flow-Chart Pedal Interface II

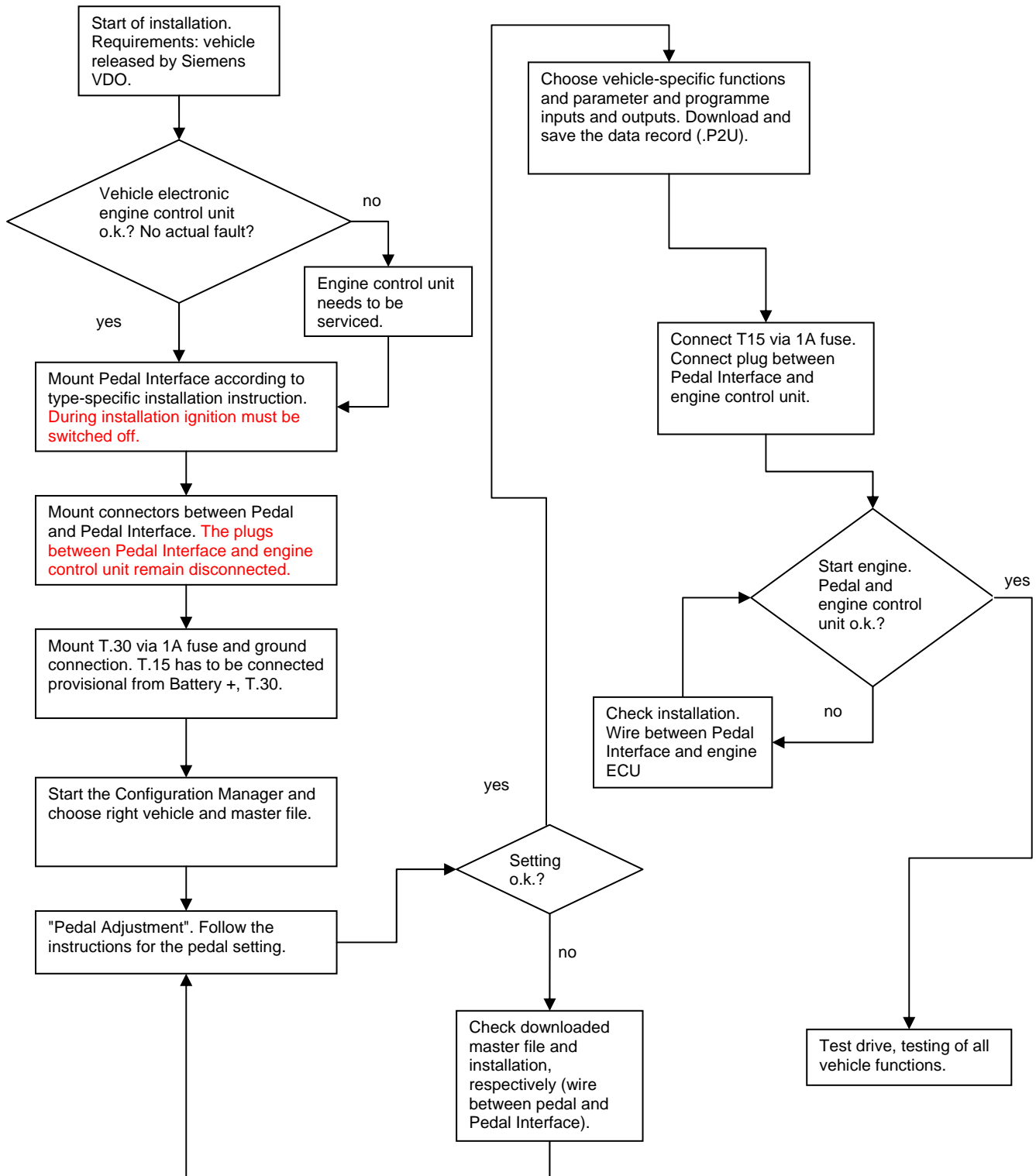

Product Manual Pedal Interface II

3. Configuration Manager

Contents

3.1 Download of a master file and pedal adjustment	2
3.2 Selection of the Vehicle-specific functions	7
3.2.1 Type of Transmission	8
3.2.2 Engine Speed Control (PTO)	9
3.2.3 Fuel Limitation* of Throttle Pedal / Additional Road Speed Limitation**	11
3.2.4 Outputs	12
3.2.5 Function Summary	13
3.2.6 Summary of the Electrical Connections	14
3.3 Definition of individual Parameters	15
3.3.1 Road Speed Limiter	16
3.3.2 Cruise Control	20
3.3.3 Engine Speed Limitation	21
3.3.4 Engine Speed Control	22
3.3.5 Additional Road Speed Limitation	25
3.3.6 Fuel Limit of Throttle Pedal	26
3.3.7 Outputs	27
3.4 Download and Storage of Vehicle-specific Data Set	28
3.4 Download and Storage of Vehicle-specific Data Set	29
3.5 Diagnostics Window	30

Product Manual Pedal Interface II

3. Configuration Manager

The Configuration Manager Requirements:

- Windows 98, ME, 2000 or XP
- USB Interface / serial Interface for Pedal Interface II dongle.

Requirements for starting the software:

- Pedal Interface II powered and dongle connected to Pedal Interface II

After starting the Configuration Manager and downloading the master file, the program guides you automatically through the programming. The parameter page only displays the chosen options from the function page. All the functions described in this manual are available with the "Premium" version. With the "Standard" and "Enhanced" version, only the functions available within the version will be displayed.

3.1 Download of a master file and pedal adjustment

Start the configuration manager; click "Next" to connect to the PI2 control unit. Should the message "A connection with a PI 2 unit could not be made" appear the possible reasons for this are as follows:

- VDO PI 2 has no voltage supply
- Dongle is not connected, please connect correctly
- The serial / USB interface "Com Port" is not recognized
- For demonstration purposes the configuration manager can be run offline without VDO PI 2. Simply press the button "Next" three times.



Once the Configuration Manager has connected to the VDO PI 2 control unit the Pedal Interface has now to be downloaded with the vehicle-specific data.

Product Manual Pedal Interface II

3. Configuration Manager

Step 1:

The below page will automatically appear if the PI2 control unit has already been programmed. To edit the existing parameters click "Next". To select a new vehicle click the "New" button.

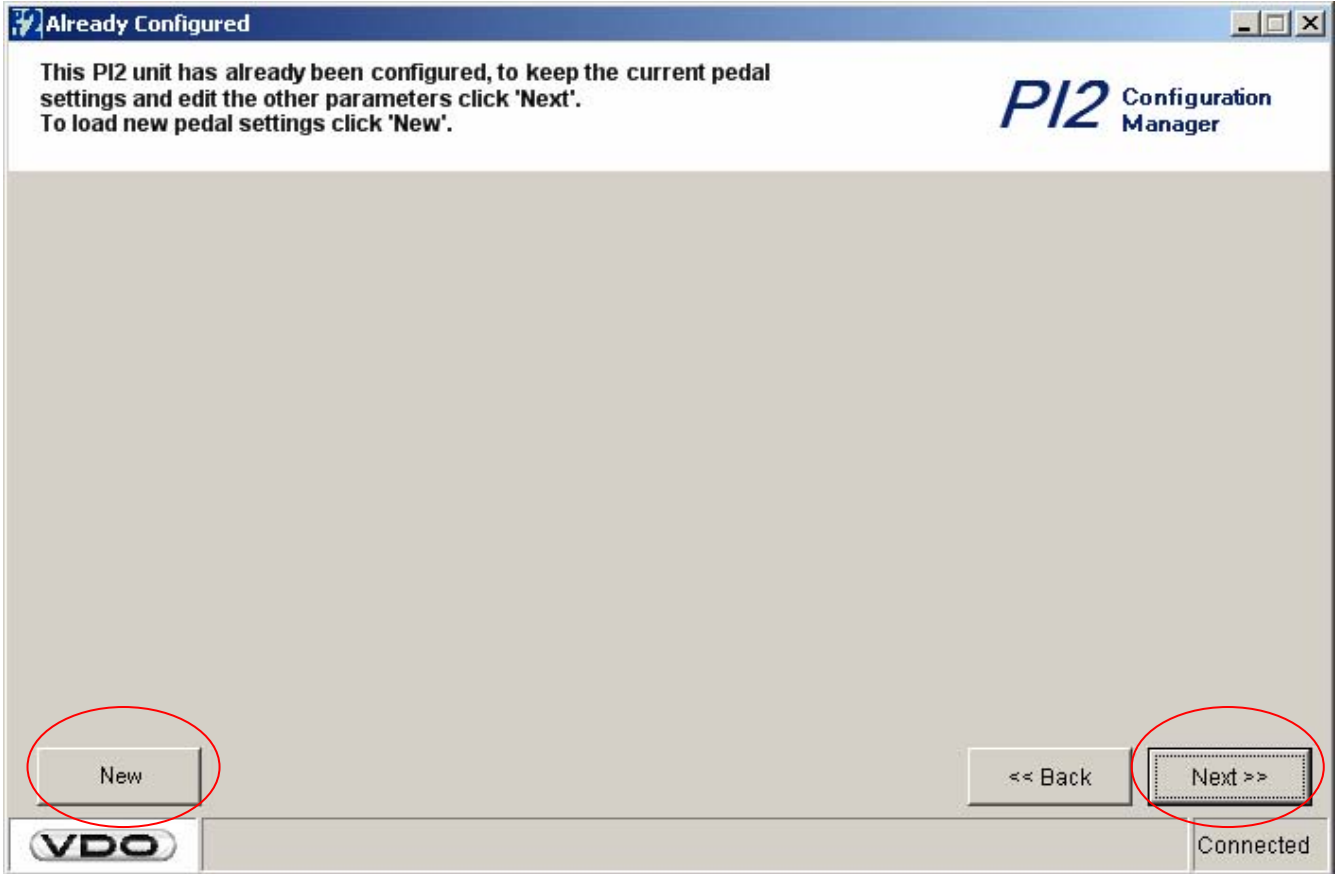

Product Manual Pedal Interface II

3. Configuration Manager

Step 2: New installation

The below page will appear if PI2 control unit has never been programmed or the New button was clicked on page shown in step 1. Now choose the manufacturer and the model. Then press "Next". The vehicle-specific data will be automatically downloaded in the control unit and the set throttle pedal page will appear.

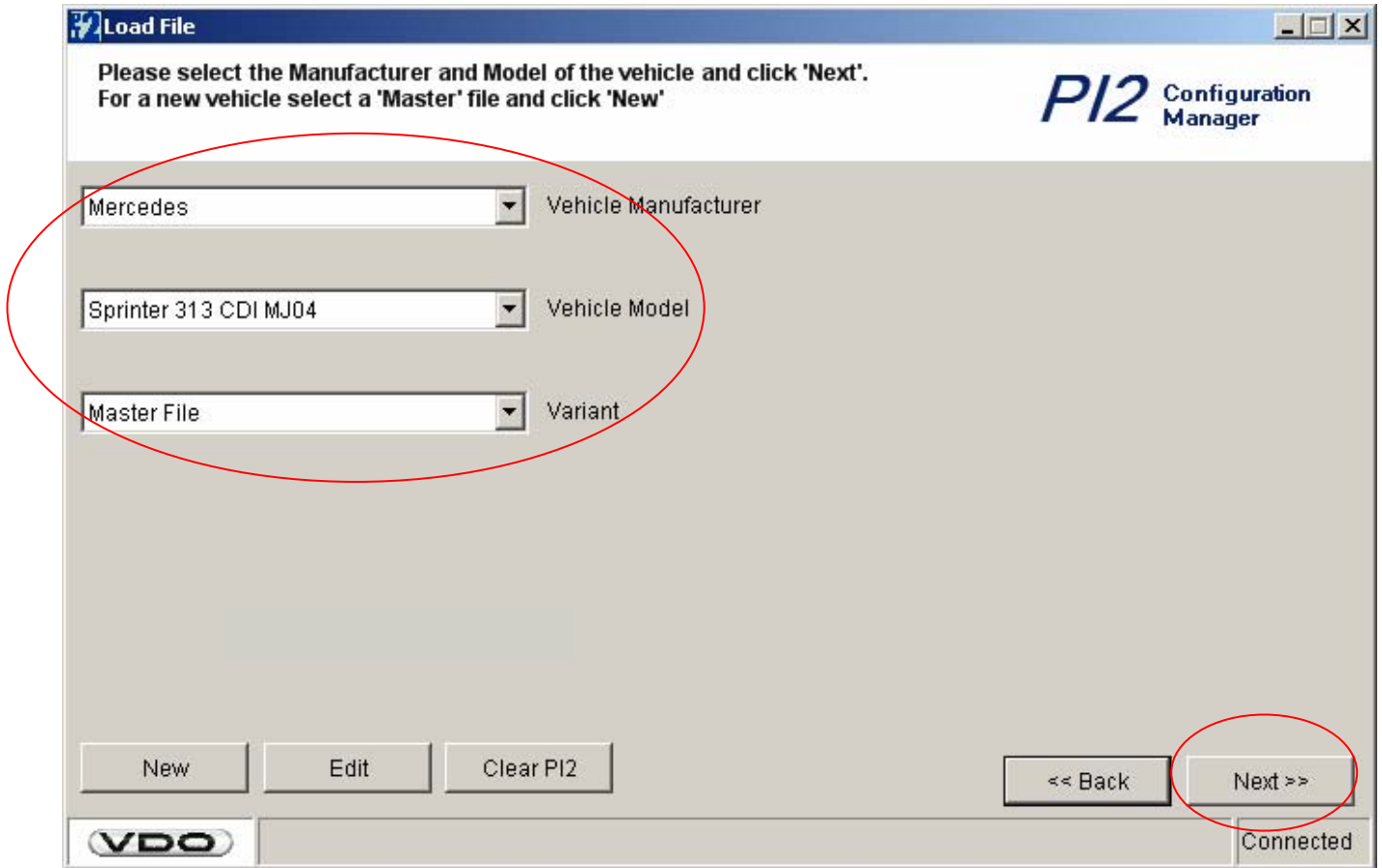

Product Manual Pedal Interface II

3. Configuration Manager

Step 3: Set Throttle Pedal

For setting throttle pedal the following is required:

- Terminal 30 (1A fused) and terminal 31 (GND) have to be connected. Terminal 15 has to be supplied via a 1A fuse provisional from terminal 30.
- The plug connection of the PI 2 control unit should not be connected to the vehicle ECU plug.

Follow the instructions in the page heading in order to set the throttle pedal and wait for an audible alarm signal. If the bars do not appear in green or you receive an error message, please check whether you have selected the right vehicle and the correct electrical connection, respectively.

Picture below: The throttle pedal needs to start at the idle position until the audible alarm and “Slowly depress the throttle pedal” appears in the page heading.

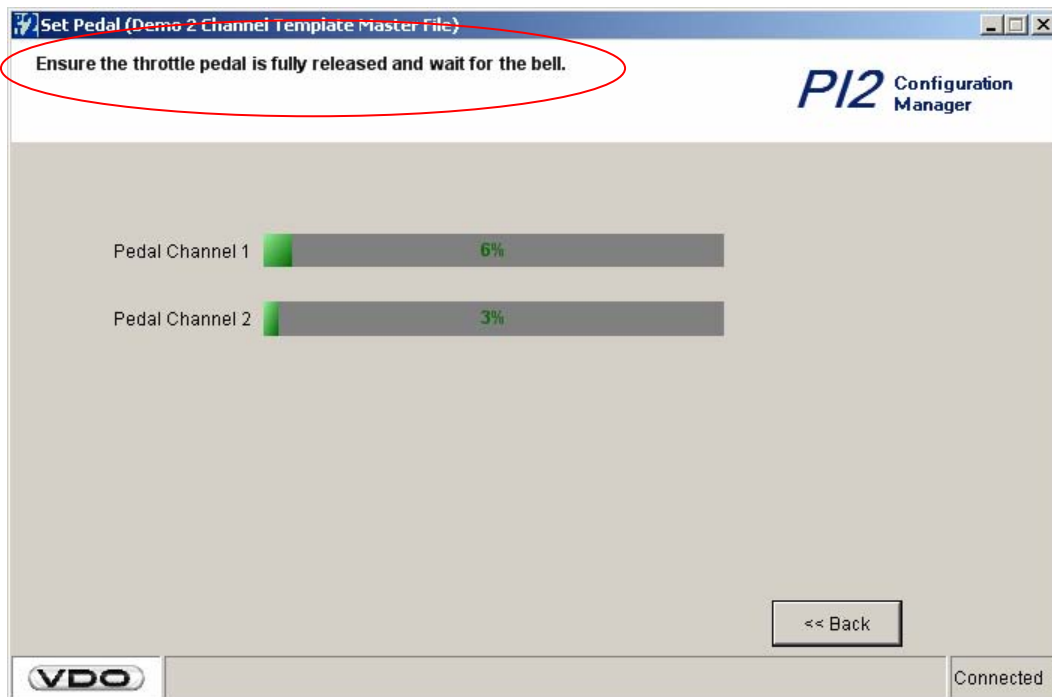

Product Manual Pedal Interface II

3. Configuration Manager

Picture below: Throttle Pedal in full throttle position. Wait until the Configuration Manager indicates for the pedal to go to idle position.

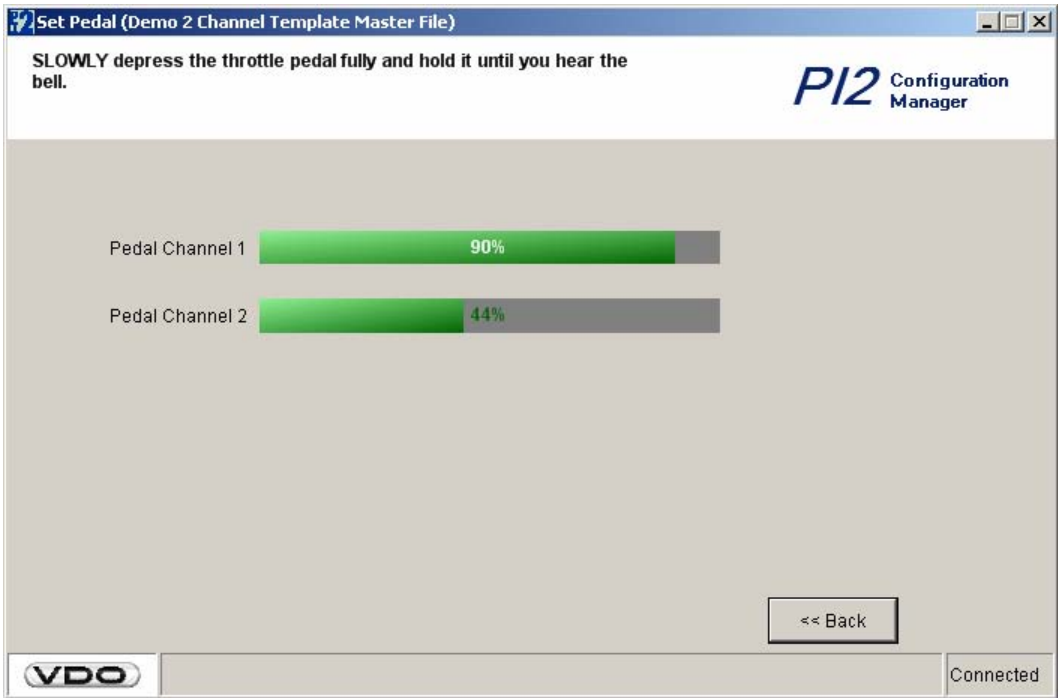

Picture below: pedal back to idle position.

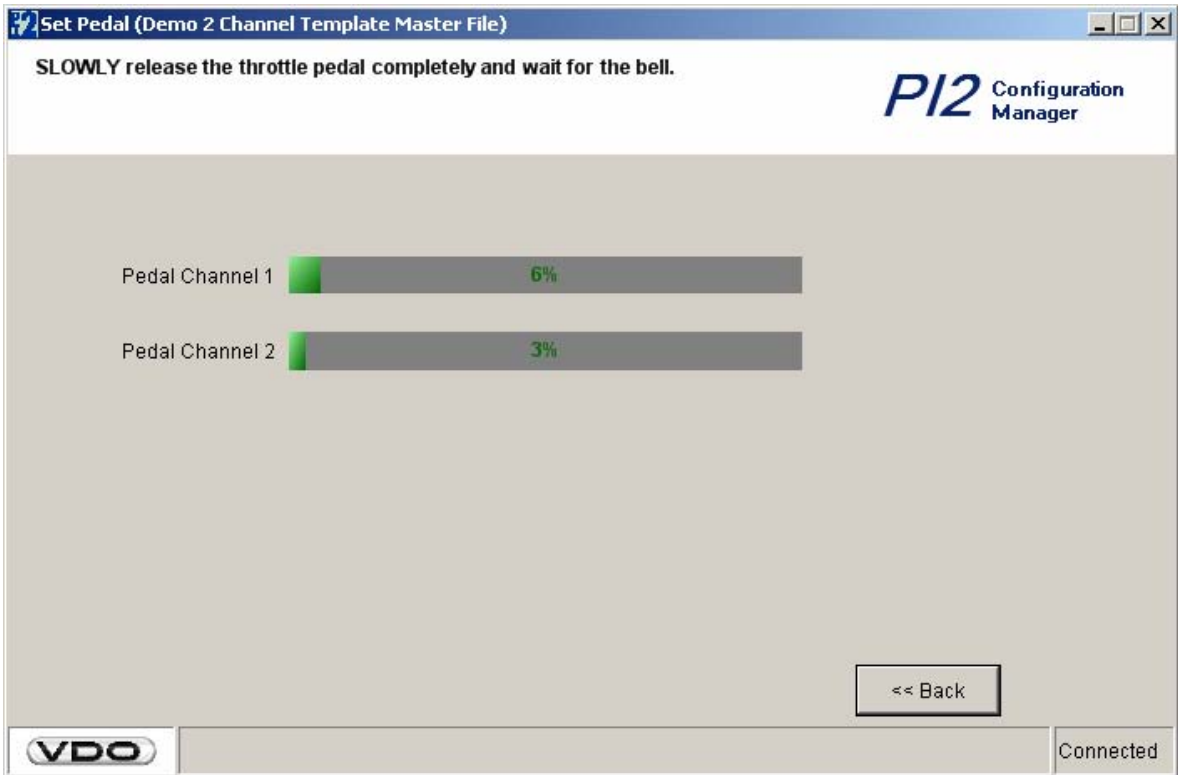

After a successful throttle pedal setting, the configuration manager will automatically download new data and open the function select page.

Product Manual Pedal Interface II

3. Configuration Manager

3.2 Selection of the Vehicle-specific functions

Select the desired functions for the vehicle.

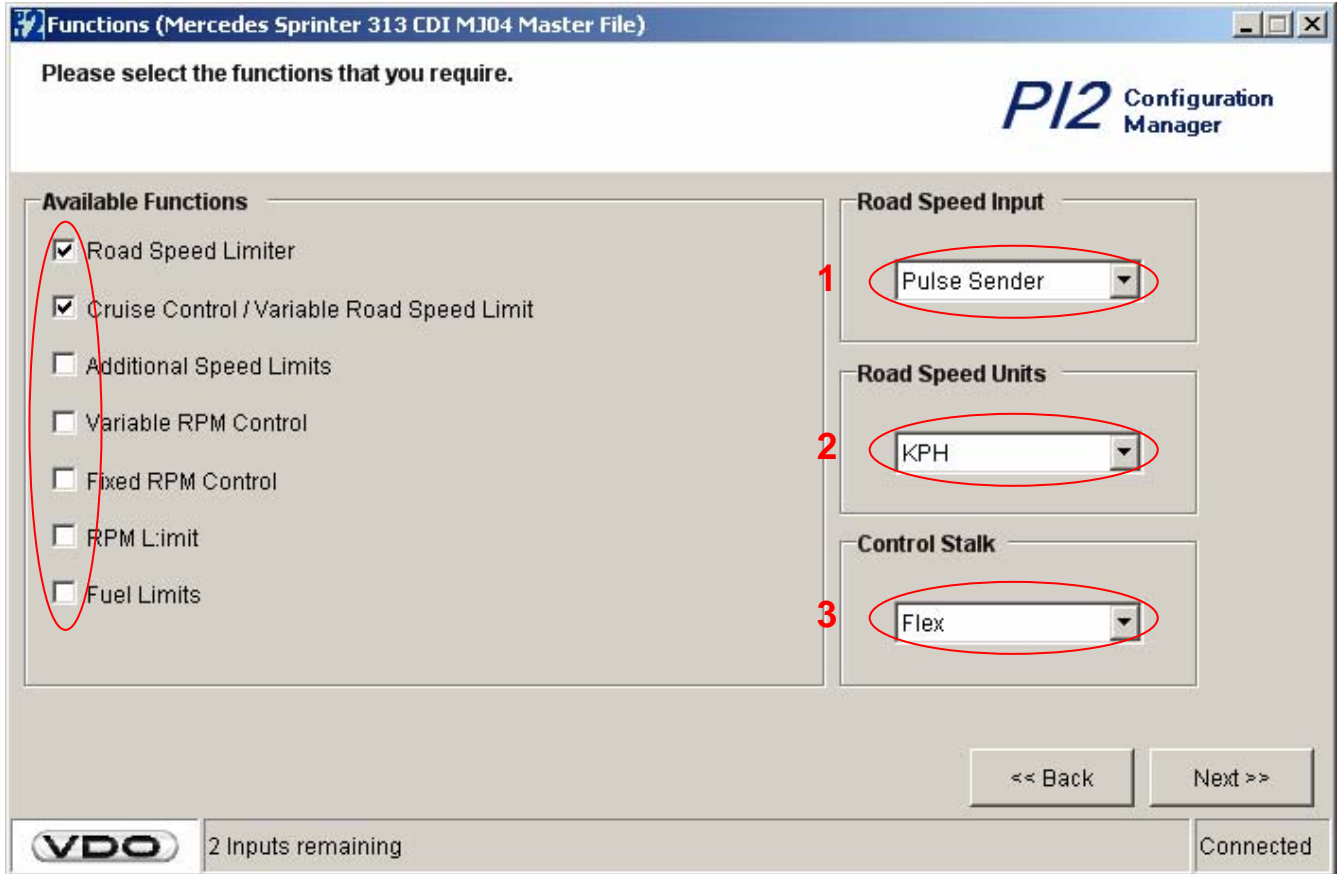

1 → Select the road speed sensor existing at the vehicle:

- Active Sensor (e.g. Hall)
- Tacho/PWM (B7/C3 tachograph)
- Inductive sensor with this selection, input pin 3 / wire no. 21 becomes input for the speed signal automatically.

2 → Select the required road speed sector.

- km/h
- mph

3 → Select the required cruise control stalk.

- none
- Standard
- LED
- Flex

Go to the next window by clicking "Next".

Product Manual Pedal Interface II

3. Configuration Manager

3.2.1 Type of Transmission

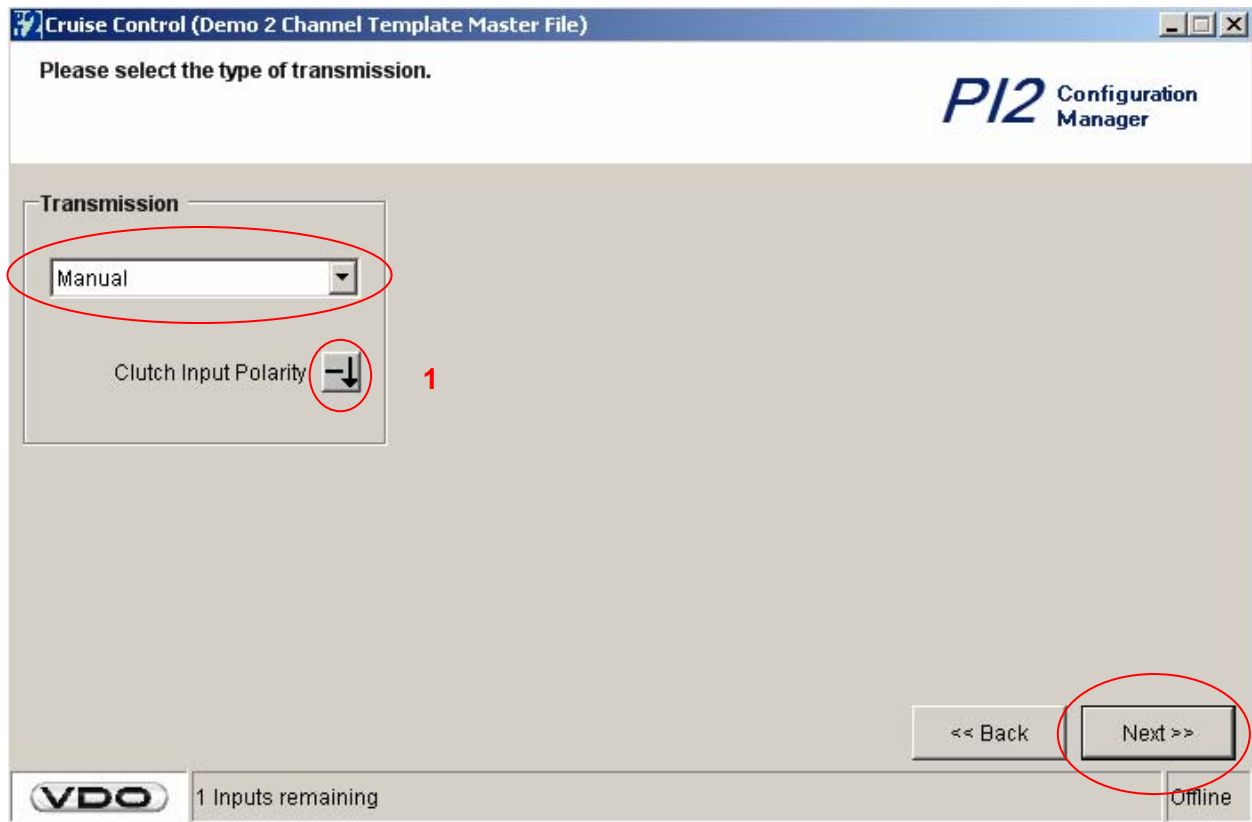

Select the respective transmission type of the vehicle.

With cruise control function and manual transmission selected the status input S2 (input pin 12, wire no. 30) will be automatically allocated for the clutch pedal input.

Button **1** will define the polarity of the clutch switch (active input).



= Cruise control function switches off with a positive signal (switch NO positive polarity).



= Cruise control function switches off with a negative or open wire signal. (switch NC according to wiring diagram of retrofitted clutch switch).

Go to the next window by pressing "Next".

Product Manual Pedal Interface II

3. Configuration Manager

3.2.2 Engine Speed Control (PTO)

Only for "Premium" version

By choosing the option "fixed engine speed control" within the window "available functions" the number of inputs can be selected.

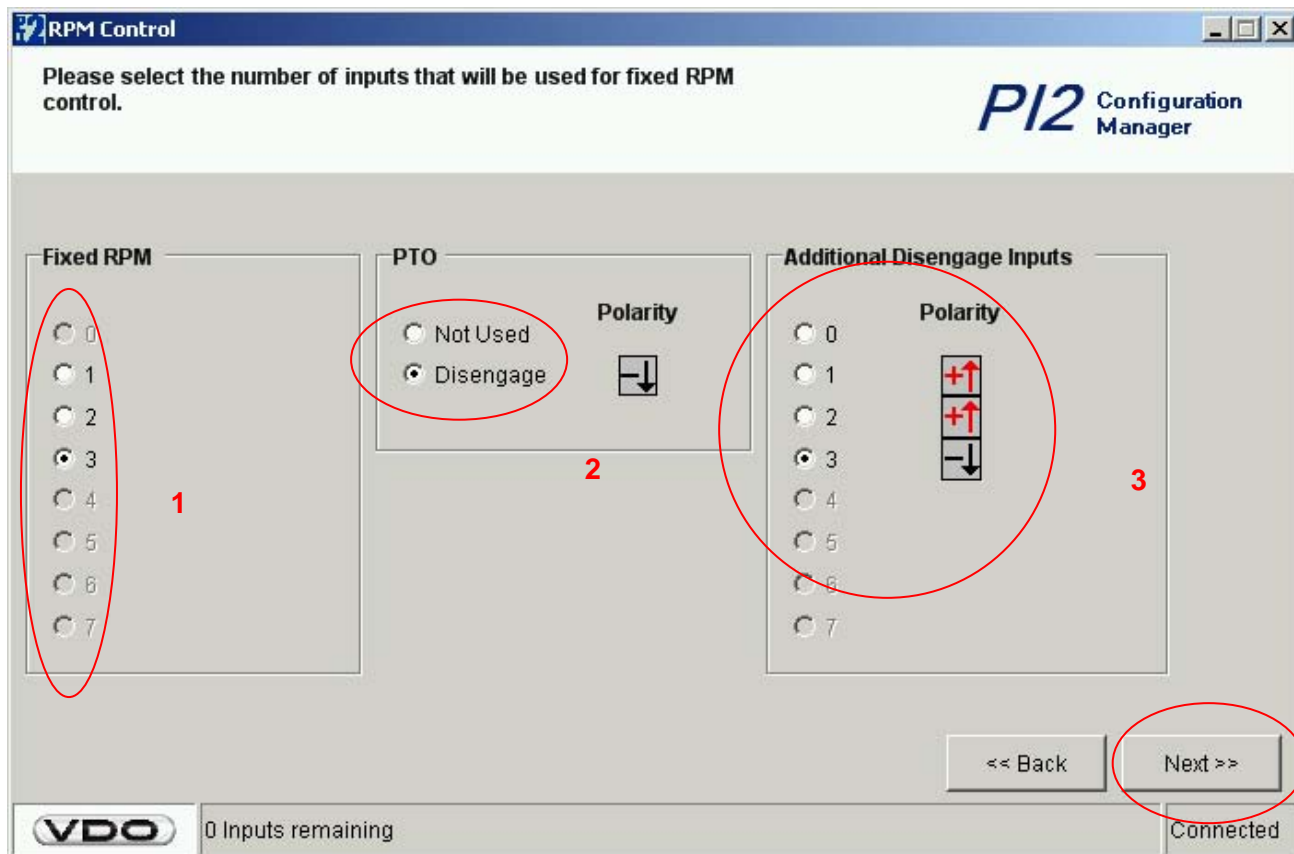

1 → - Number of fixed engine speed inputs (only positive polarity allowed)

2 → - PTO-Disengage

If the PTO release has been selected, the status input S3 (input pin 11, wire no. 29) will be automatically assigned (for safety reasons PTO disengage should be activated with a positive signal).

3 → - Additional disengage – inputs for engine speed control disengage and selection of the active signal input polarity. With an active signal, the rpm control switches off.

Polarity Explanation:

 = Engine speed **switch off** with a **positive** signal

 = Engine speed **switch off** with a **negative** signal

Go to the next window by pressing "Next".

Product Manual Pedal Interface II

3. Configuration Manager

3.2.2 Engine Speed Control

Only for "Premium" version

The window below allows the functionality for the Variable RPM Control to be defined.

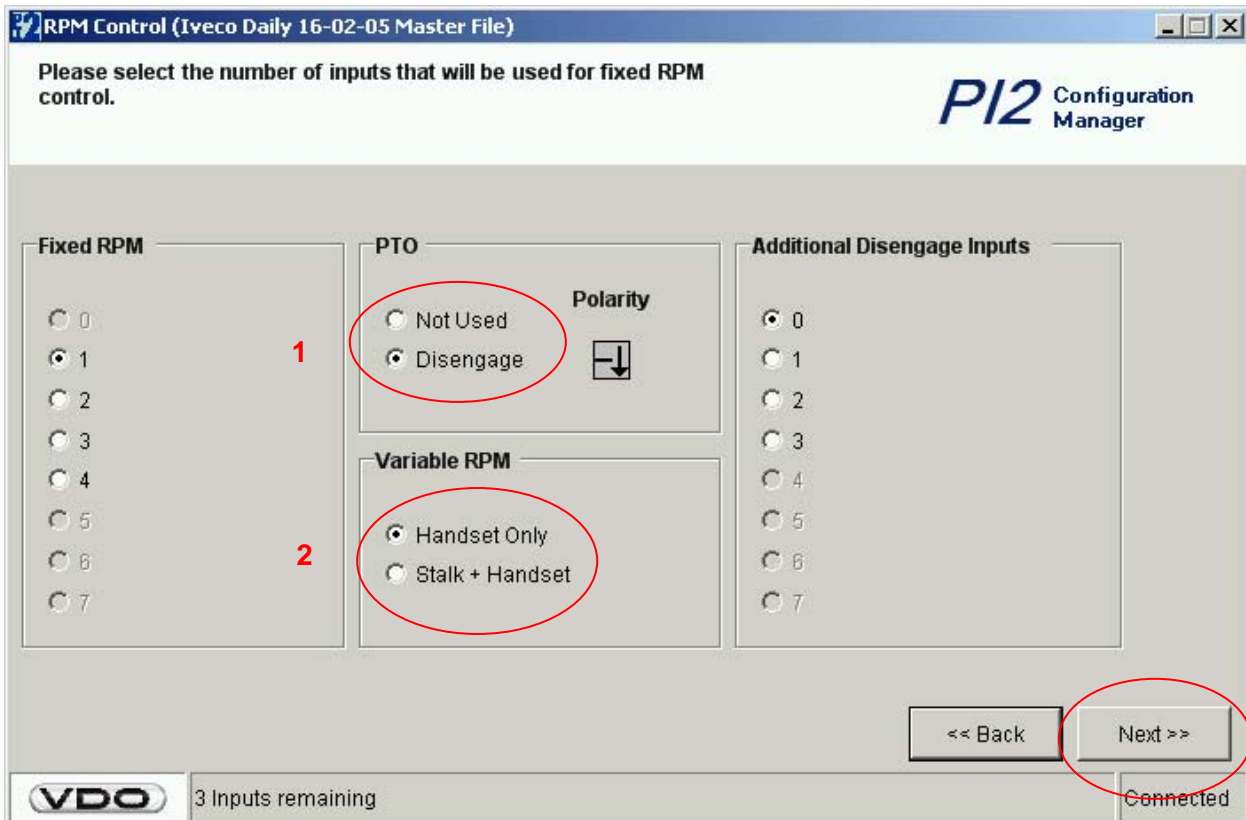

1 → - PTO Release

If the PTO release has been selected, the status input S3 (input pin 11, wire no. 29) will be automatically assigned, for safety reasons PTO disengage should be activated with a positive signal.

2 → - Selection of the operating device for Variable RPM Control.

For safety reasons, when using the LED or Flexible control stalk for this function, there are two inputs which have to be used for PTO release. In addition to Status – Input 3, Status - Input 4 (wire no. 28, Input 10) has to be connected.

Go to the next window by pressing "Next".

Product Manual Pedal Interface II

3. Configuration Manager

3.2.3 Fuel Limitation* of Throttle Pedal / Additional Road Speed Limitation**

* Only "Premium" version

** Only "Enhanced and Premium" version

By choosing the option "Fuel limitation of throttle pedal or additional road speed limitation" within the Available Functions page, the various inputs can be defined.

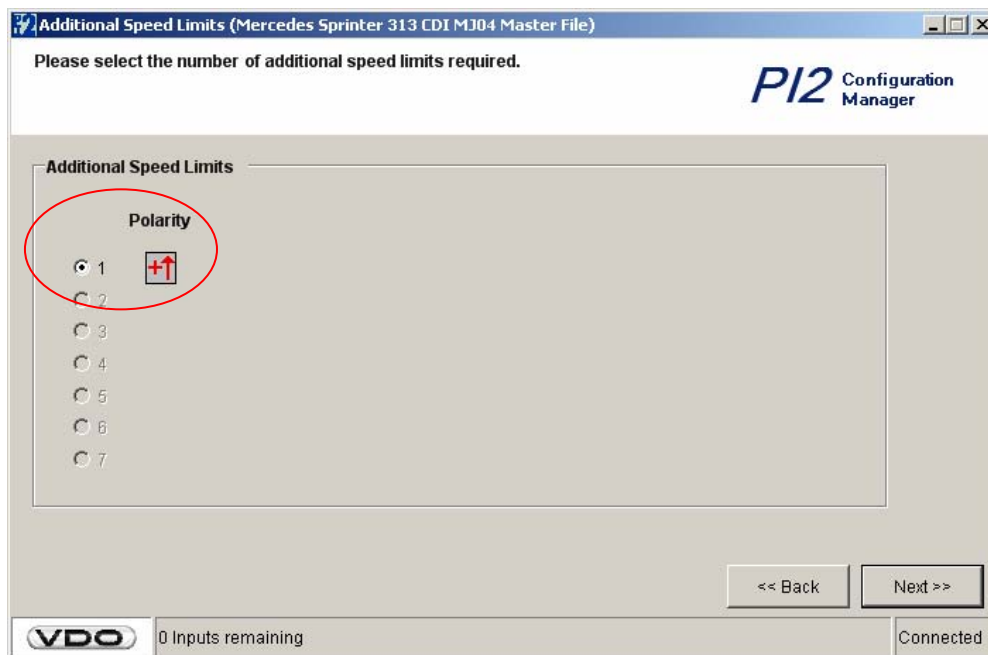
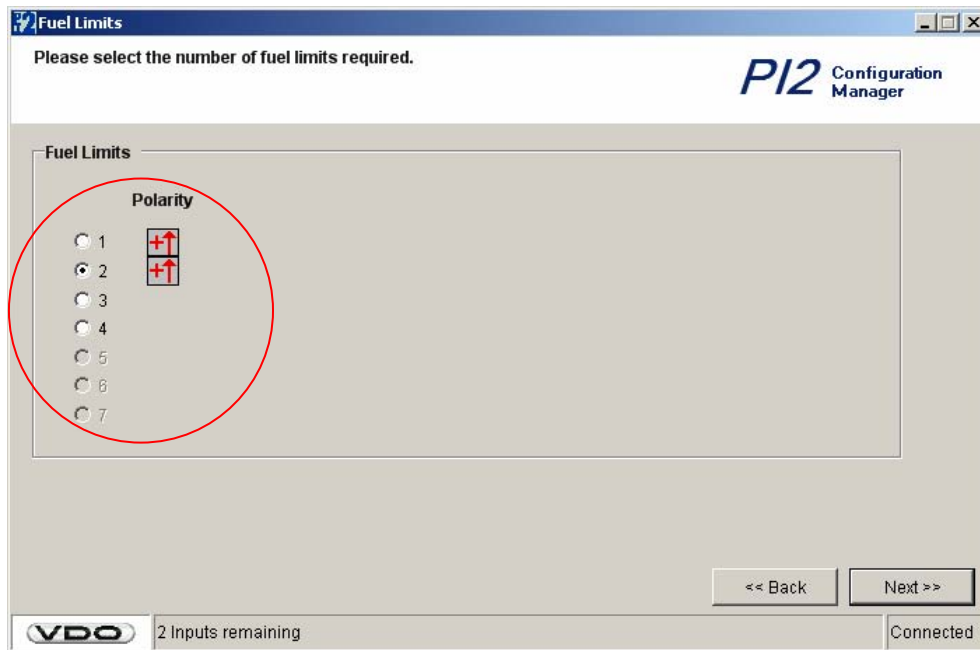

- Select number and polarity of the Fuel limit inputs.
- Select number and polarity of additional road speed limitations.

Go to the next window by pressing "Next".

Product Manual Pedal Interface II

3. Configuration Manager

3.2.4 Outputs

The function outputs can be selected as "On" or "Off".

The screenshot shows a software window titled "Outputs (Demo 2 Channel Template Master File)". The window contains the following elements:

- Header:** "Please select the default function for each of the outputs." and the "PI2 Configuration Manager" logo.
- Output 1 Section:** A list of radio button options: None, Road Speed, RPM, Cruise ON (selected), and Variable RPM.
- Output 2 Section:** A list of radio button options: None, Road Speed, RPM, Variable RSL ON (selected), and Variable RPM.
- Summary Row 1:** "Cruise Output" with a red "ON" button and the text "if cruise control active".
- Summary Row 2:** "Variable RSL Output" with a red "ON" button and the text "if variable road speed limit active".
- Navigation:** "<< Back" and "Next >>" buttons. The "Next >>" button is circled in red.
- Footer:** The "VDO" logo on the left and a "Connected" status indicator on the right.

The outputs can be programmed for the following:

- Dependent on road speed
- Dependent on engine speed
- Cruise control on
- Variable road speed limitation on
- Variable engine speed limitation on

Go to the next window by pressing "Next".

Product Manual Pedal Interface II

3. Configuration Manager

3.2.5 Function Summary

Here, you will get an overview of all previously selected functions.

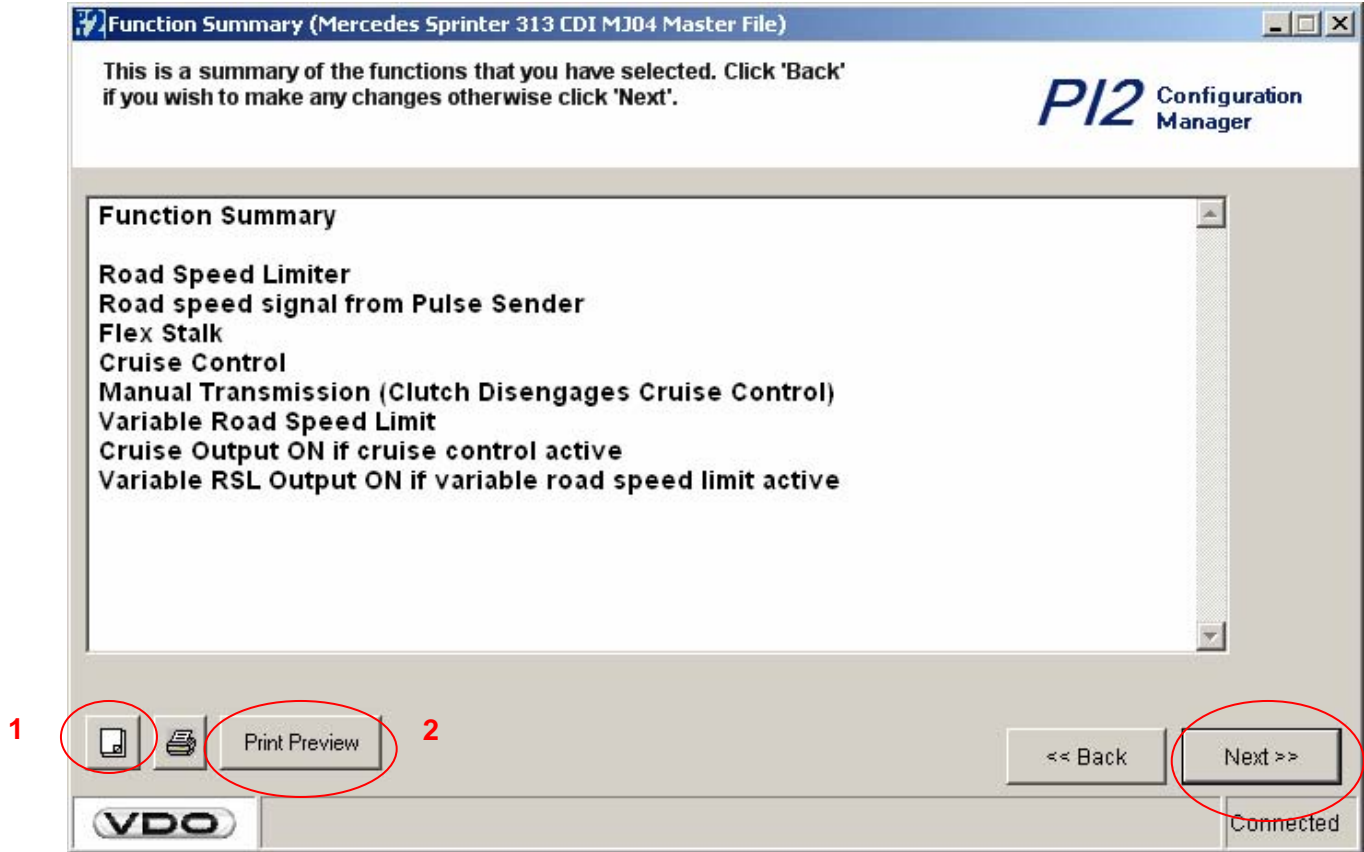

1 → Opens the window "Page setup"

2 → Opens the window "Print Preview"

Go to the next window by pressing "Next".

Product Manual Pedal Interface II

3. Configuration Manager

3.2.6 Summary of the Electrical Connections

Here, you can view and print the overview of the previously selected electrical connections and the corresponding pin assignments. Please compare this summary with the vehicle's electrical connections. In case of deviation, please check the connections on the vehicle.

Wiring Details

This is a summary of the wiring required for the functions that you have selected

PI2 Configuration Manager

Pin	Polarity	Wire Colour	Function	Comment
19			Permanent Supply	
20			Vehicle Ground	
21			Engine Speed Input	
22			Road Speed Input (Pu	
23				
24			Vehicle Ignition	
25	Negativ		RPM Disengage Input	
26	Positive		RPM Disengage Input	
27	Negativ		RPM Disengage Input	
28	Positive		Fixed RPM Input 3	
29	Positive		PTO Input	
30	Positive		Fixed RPM Input 2	
31	Positive		Fixed RPM Input 1	
32			RPM Output 2	
33	ON		RPM Output 1	

Print Preview

<< Back

Next >>

VDO 0 Inputs remaining Connected

Go to the next window by pressing "Next".

Product Manual Pedal Interface II

3. Configuration Manager

3.3 Definition of individual Parameters

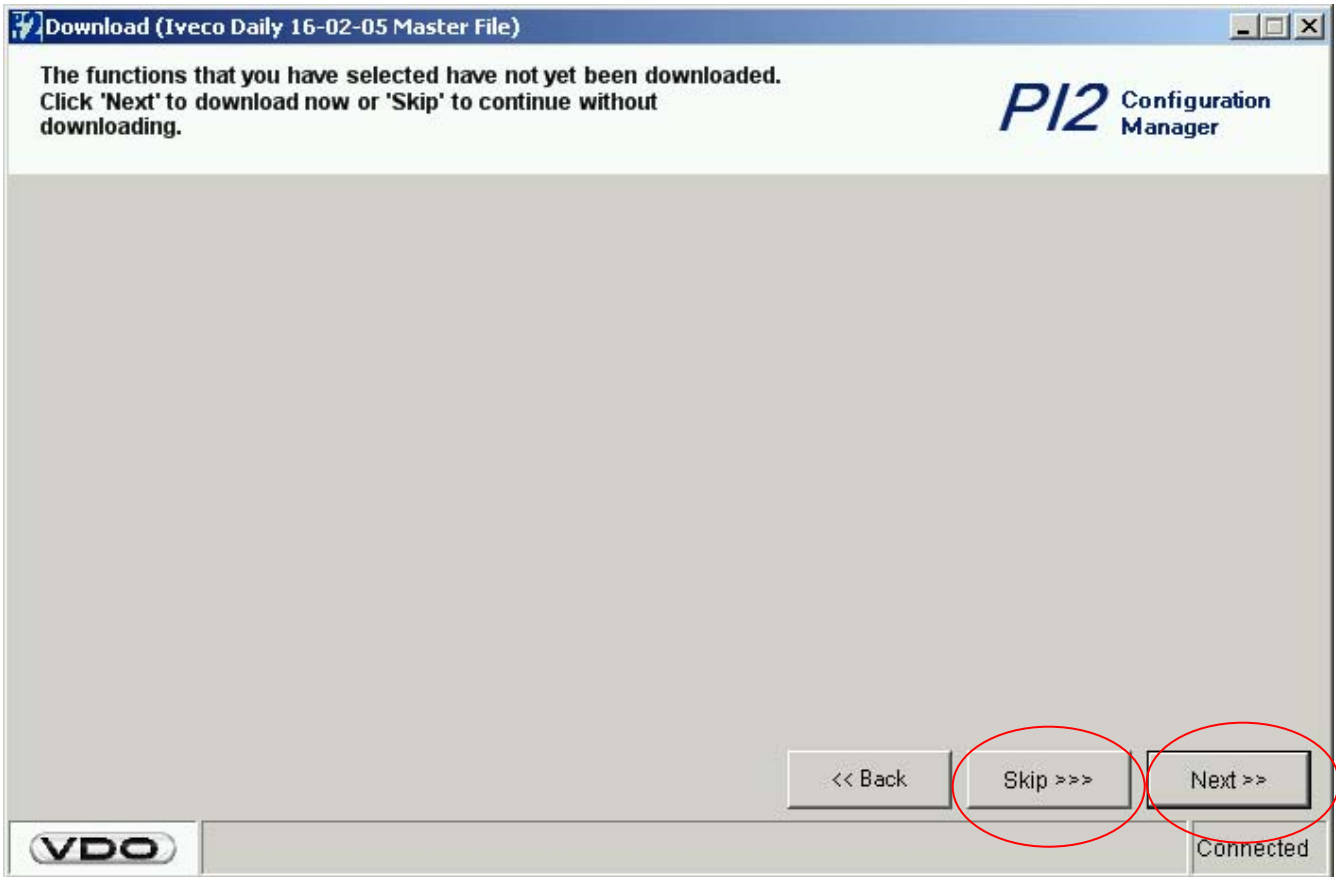

Click skip you will go to the next window **without** a download.

Click next there will be an automatic download of the functionality selected before reaching the next window.

Product Manual Pedal Interface II

3. Configuration Manager

3.3.1 Road Speed Limiter

Select the required maximum road speed limiter parameters.

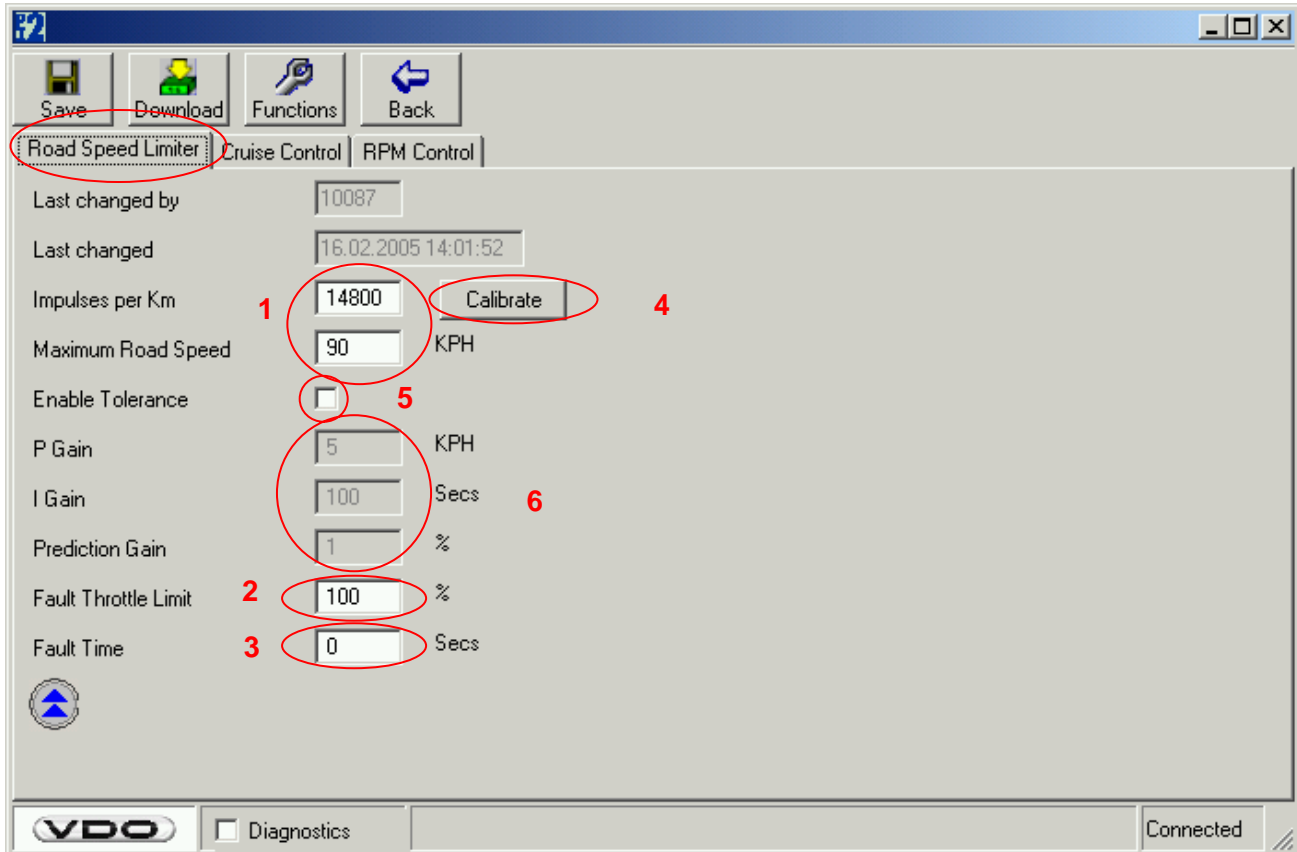

- 1 → Input of road speed pulses and maximum road speed.
- 2 → Input of throttle pedal limitation after breakdown of road speed signal (100% = no limitation, 0% = full limitation)
- 3 → Input of time, which defines for how long after recognition of a v-signal error full throttle is available.

Function 2 and 3:

Control function: fault throttle limitation programmable 0% - 100% with the loss of v-signal and the fault time from 0 to 60 seconds. The fault throttle limit activates with a breakdown of v-signal while accelerator pedal position lies above the programmable fault throttle limit for longer then the adjustable fault time. The fault time must be set allowing enough time for a vehicle driven from a stand still position to generate a speed signal. This means that when driving from a stand still position the road speed signal has to be recognized by the Pedal Interface ECU before the preprogrammed fault time lapses. If not, the pedal will be limited to the pre-set value.

- 4 → Via the button "Calibrate" the number of distance pulse can be adjusted
- 5 → If this function is selected, the controller adds 3.5 kph on the maximum road speed limit.
- 6 → Internal controller adjustment of the control parameters for road speed function. These values are for information only.

Product Manual Pedal Interface II

3. Configuration Manager

3.3.1 Road Speed Limiter

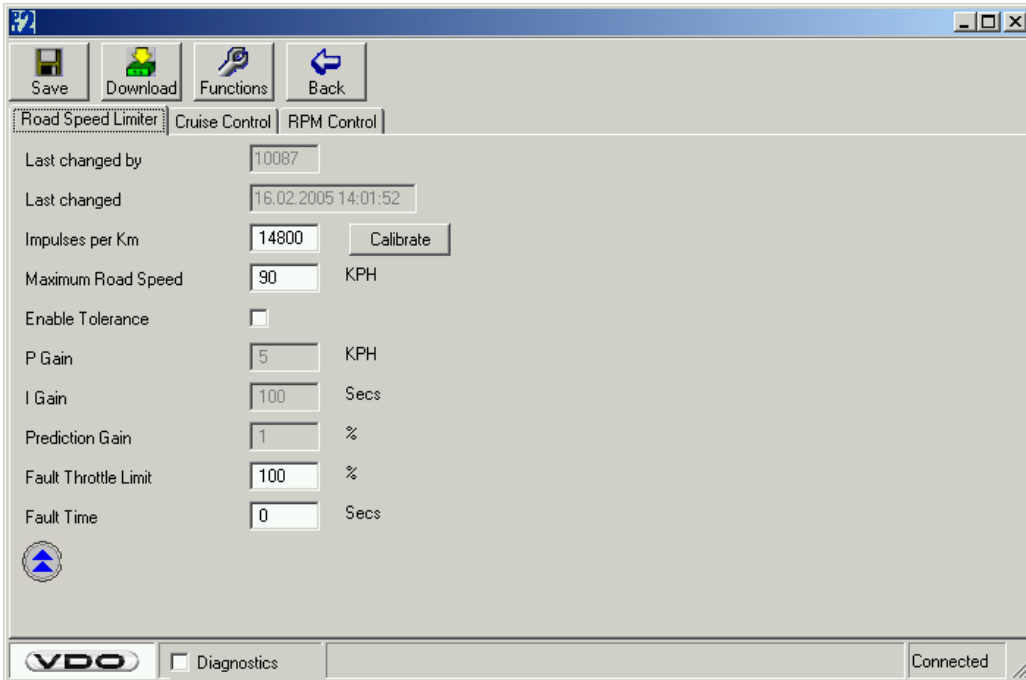

1 → If the pulses are known, it can be programmed directly to this Window. If not a calibration function is possible.

Measuring the road speed pulses

Press the bottom "Calibrate"

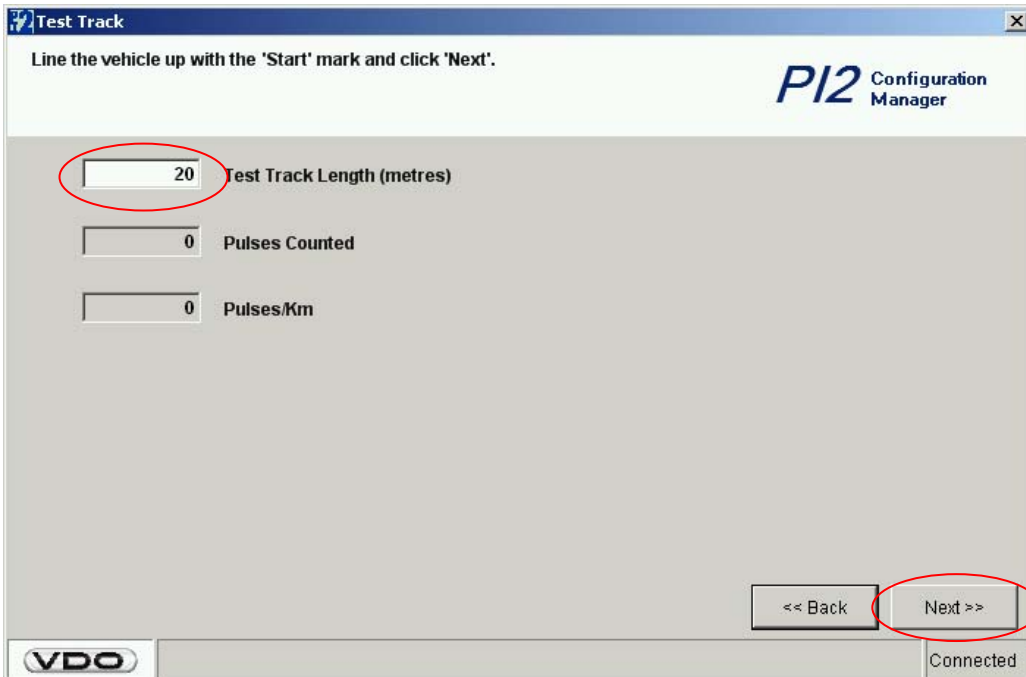

Program the length of the test track.

Press next.

Product Manual Pedal Interface II

3. Configuration Manager

3.3.1 Road Speed Limiter

Move the vehicle until full length of the test rack.

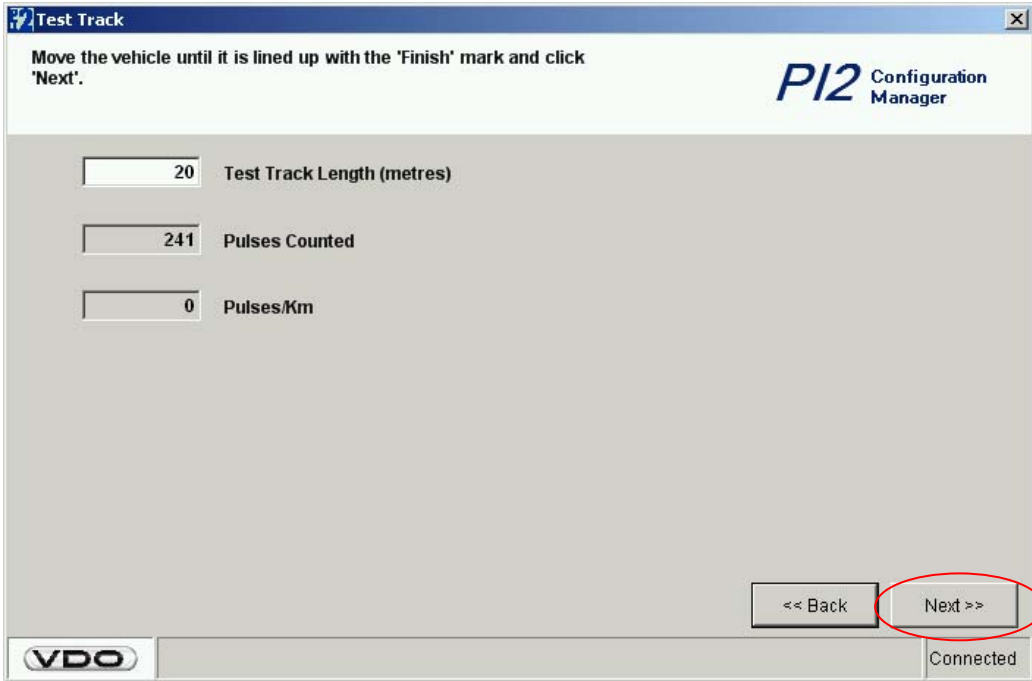

Press next.

The pulse/km will be counted.

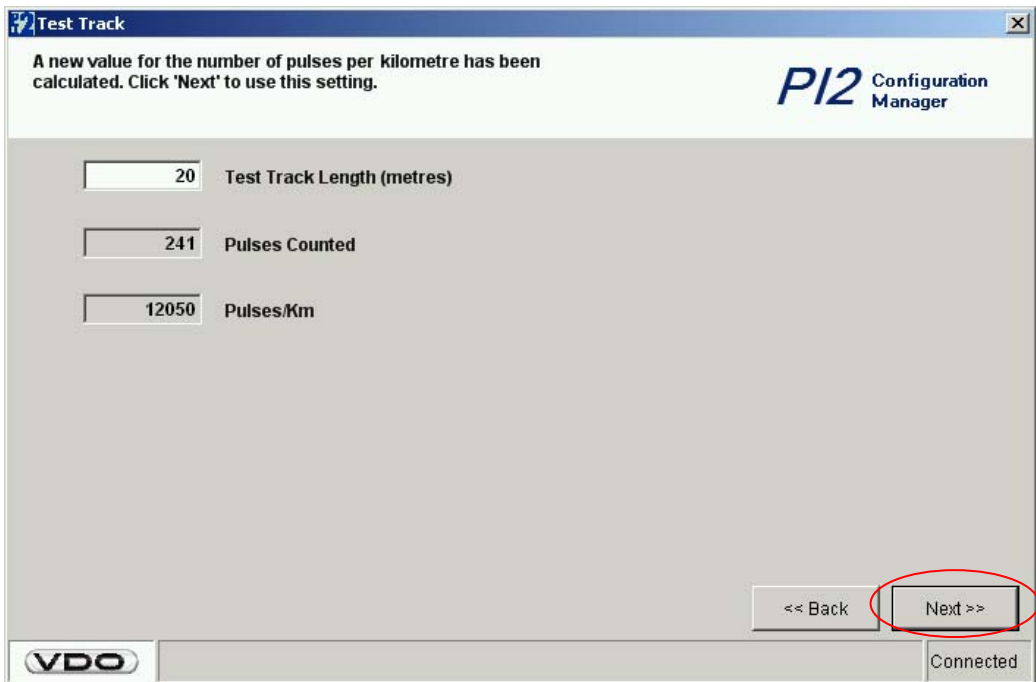

Press next.

Product Manual Pedal Interface II

3. Configuration Manager

3.3.1 Road Speed Limiter

The pulses/km will be automatically written into the window "Road Speed Limiter".

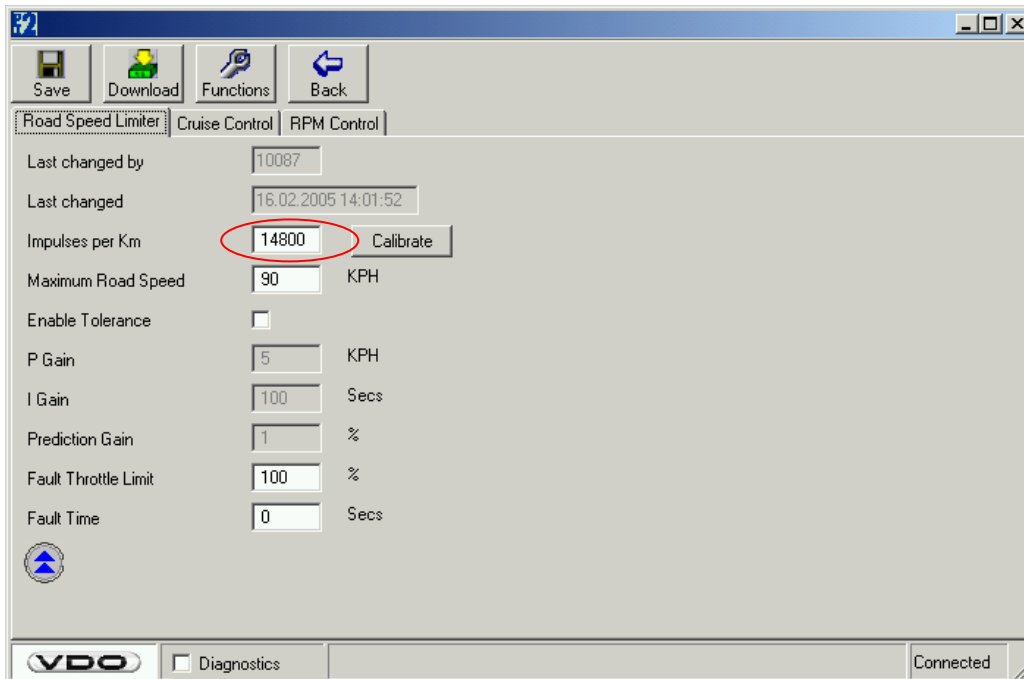

Product Manual Pedal Interface II

3. Configuration Manager

3.3.2 Cruise Control

Select required Cruise Control parameters.

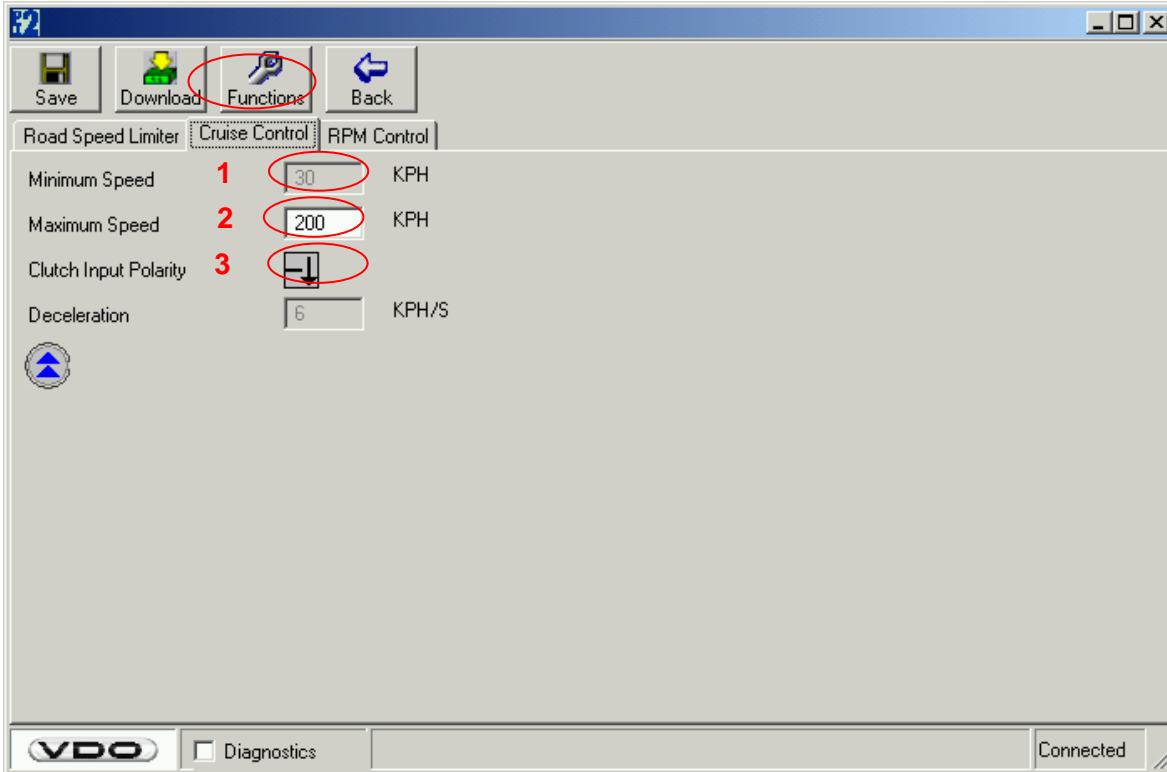

- 1 → Input of maximum set road speed within cruise control operation.
- 2 → Disengage function of the clutch switch will be defined (active input).



= Cruise Control switches of with positive signal



= Cruise Control switches of with negative signal or open wire

- 3 → Internal programming for switching off the cruise control if the deceleration is more than the pre-programmed value, in case of break switch fault. (6 km/h ~ 1, 5 m/s²)

Product Manual Pedal Interface II

3. Configuration Manager

3.3.3 Engine Speed Limitation

Select the required engine speed limitation.

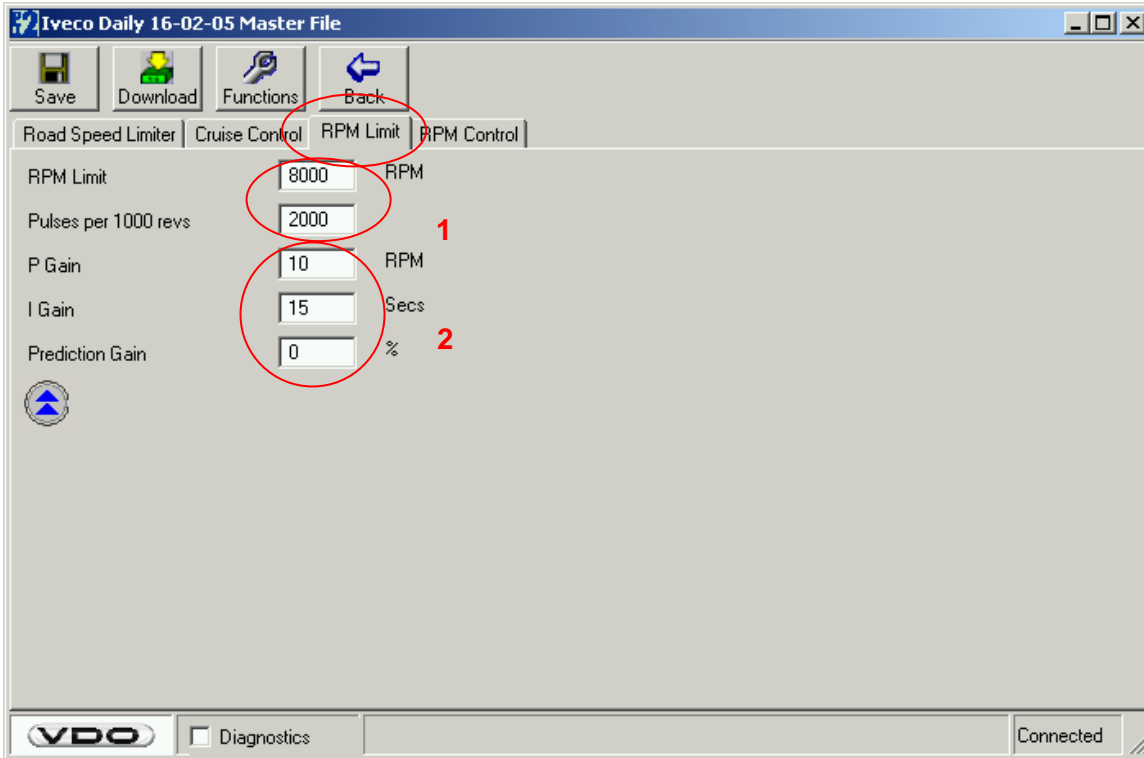

1 → Input of desired engine speed limit and the vehicle-specific engine speed pulses. If the engine speed limitation is not in use, 8000 rpm should be entered as the limit.

2 → These parameters define the control quality of the rpm limiter.

Description to adjust the rpm limiter

Adjustments should be in the following order P→I→Prediction Gain. Make sure that default settings are P=50, I=100 and Prediction Gain=1.

In this case I and Prediction Gain have no influence on the adjustment of P.

During a test drive make sure the rpm limiter operation is surge-free.

If the operation is not sufficient adjust the P-Gain value from 50 to 100.

Repeat this procedure (double P-Gain200.....400) until the engine limit runs smoothly.

Important: Too high P-value results in a slow and sluggish operation.

Adjust I-Gain. Reduce the value by halve (100....50....25) and check if the vehicle works smoothly.

Should there be any overshoot of maximum rpm, increase the Prediction Gain value step by step (1% →2%→3%). The Prediction Gain will reduce the overshoot. Ascertain the ideal value for a smooth operation.

Product Manual Pedal Interface II

3. Configuration Manager

3.3.4 Engine Speed Control

Select the required engine speed control. Here, you can define the parameters for fixed and variable engine speed control.

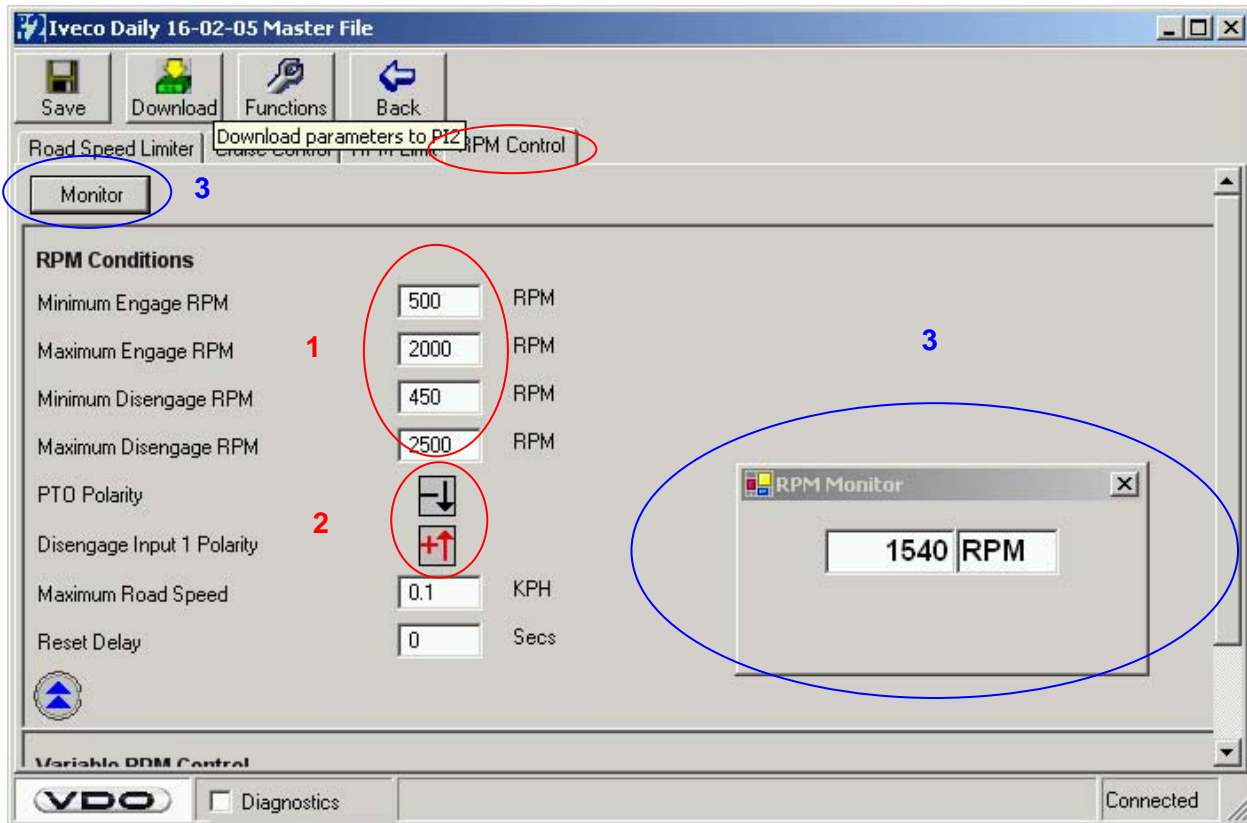

1 → Input the min, max engage and disengage of rpm control.

2 → Input the polarity of the disengage inputs. Switch "off" with active signal.

Explanation:  = Engine speed **switch off** with a **positive** signal

 = Engine speed **switch off** with a **negative** signal

3 → Via the button "Monitor" the actual engine speed can be called up.

Product Manual Pedal Interface II

3. Configuration Manager

3.3.4 Engine Speed Control

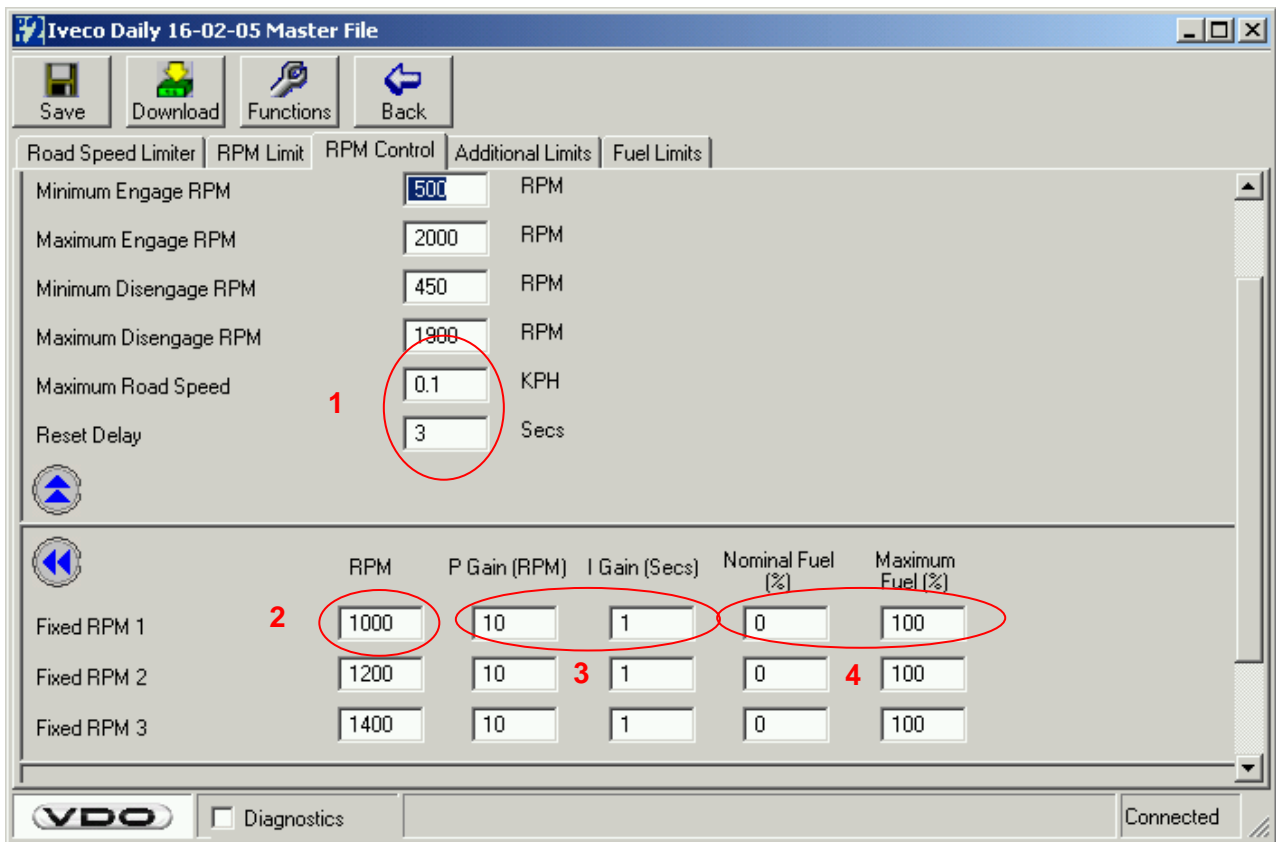

1 → Maximum Road Speed – Allows an additional disengage function of the rpm control when the road speed exceeds the speed set in this window.

Reset Delay: → Safety Function when the rpm control has been switched off via an illegal disengaged i.e. not turned off via normal off button. The reset delay function will limit the vehicle pedal to 0 % throttle. To regain the throttle pedal output the ignition has to be switched off for minimum of 10sec. When the ignition is switched back on the 100% throttle will be returned after the programmed reset delay time has lapsed. To remove the reset delay function programme 0 secs

Attention: If the fixed rpm control switch is still active the rpm control comes up immediately after an ignition reset. For this reason "Reset Delay" time have to be at min. 1sec.

For restarting the variable rpm control the reactivation has to be done via hand set.

2 → Requested fixed engine speed for respective status input.

3 → Control parameters (depending on the engine's load).

4 → Start and End position of the engine speed controller.

Product Manual Pedal Interface II

3. Configuration Manager

3.3.4 Engine Speed Control

Parameter for the adjustment of the variable engine speed control.

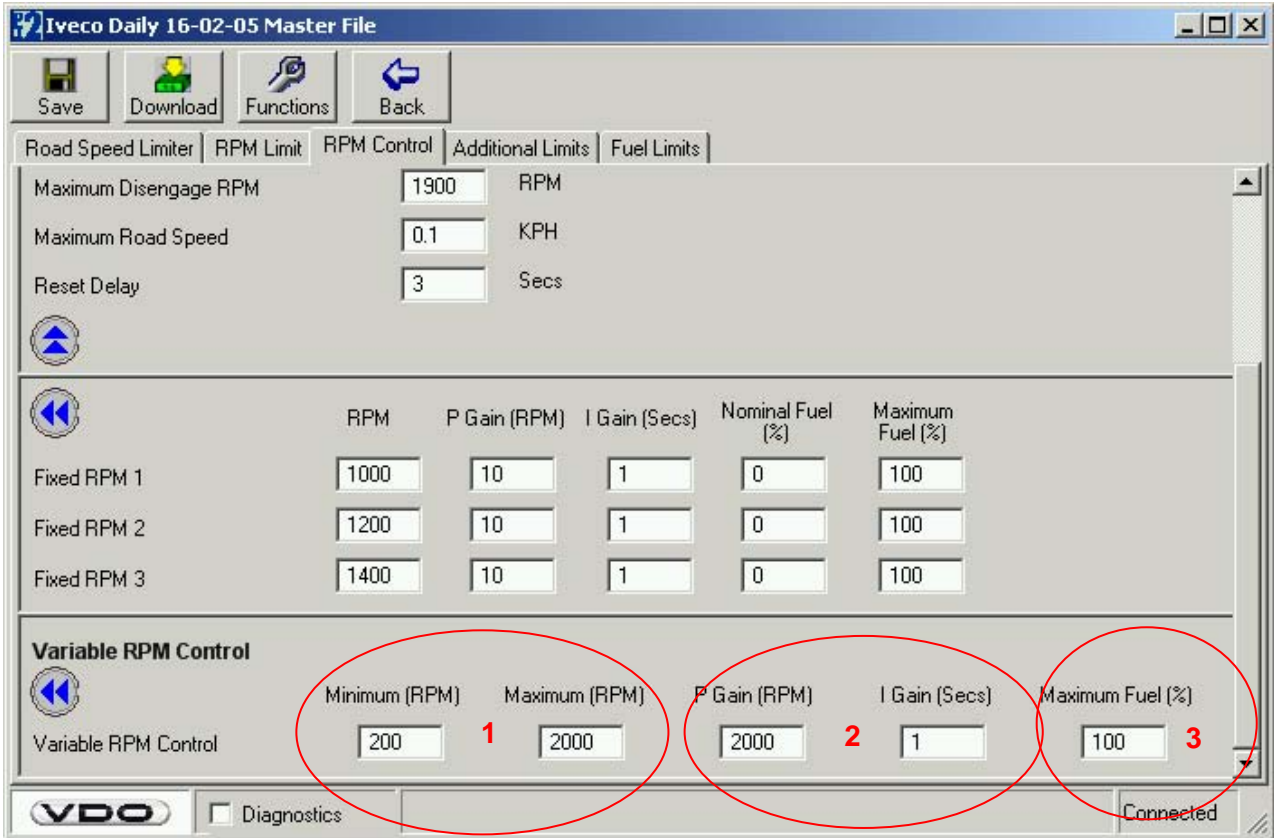

- 1 → Minimum and maximum rpm which can be selected by using the hand-set or stalk.
- 2 → Control parameters (depending on the engine's load).
- 3 → End position of the engine speed controller.

Product Manual Pedal Interface II

3. Configuration Manager

3.3.5 Additional Road Speed Limitation

Select the required "Additional Limits".

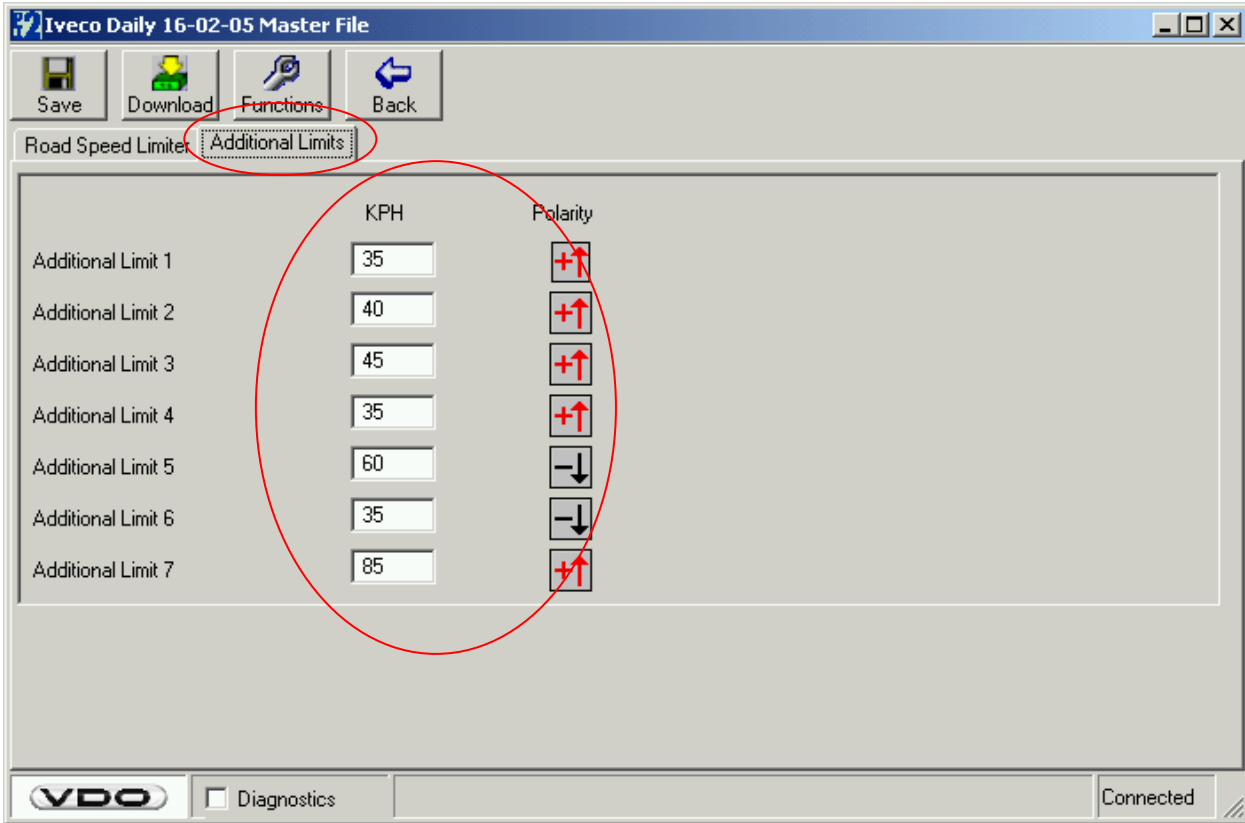

- Input of desired additional road speed limitation and polarity of respective selected status input.

Product Manual Pedal Interface II

3. Configuration Manager

3.3.6 Fuel Limit of Throttle Pedal

Select the required "Fuel Limits".

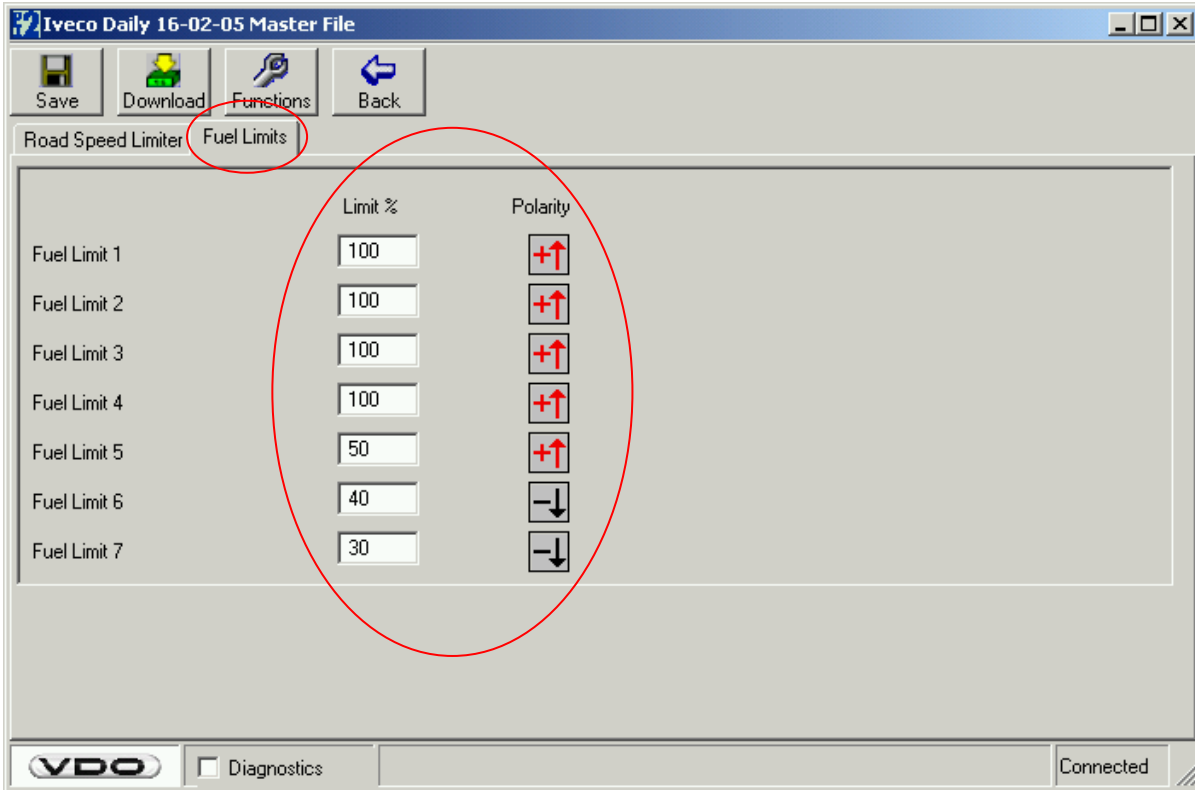

- Input of desired fuel limitation and polarity of the respective selected status input (100% = no limitation, 0% = full limitation).

Information: The fuel limit can be overridden with cruise control function.

Product Manual Pedal Interface II

3. Configuration Manager

3.3.7 Outputs

Select the required "Outputs".

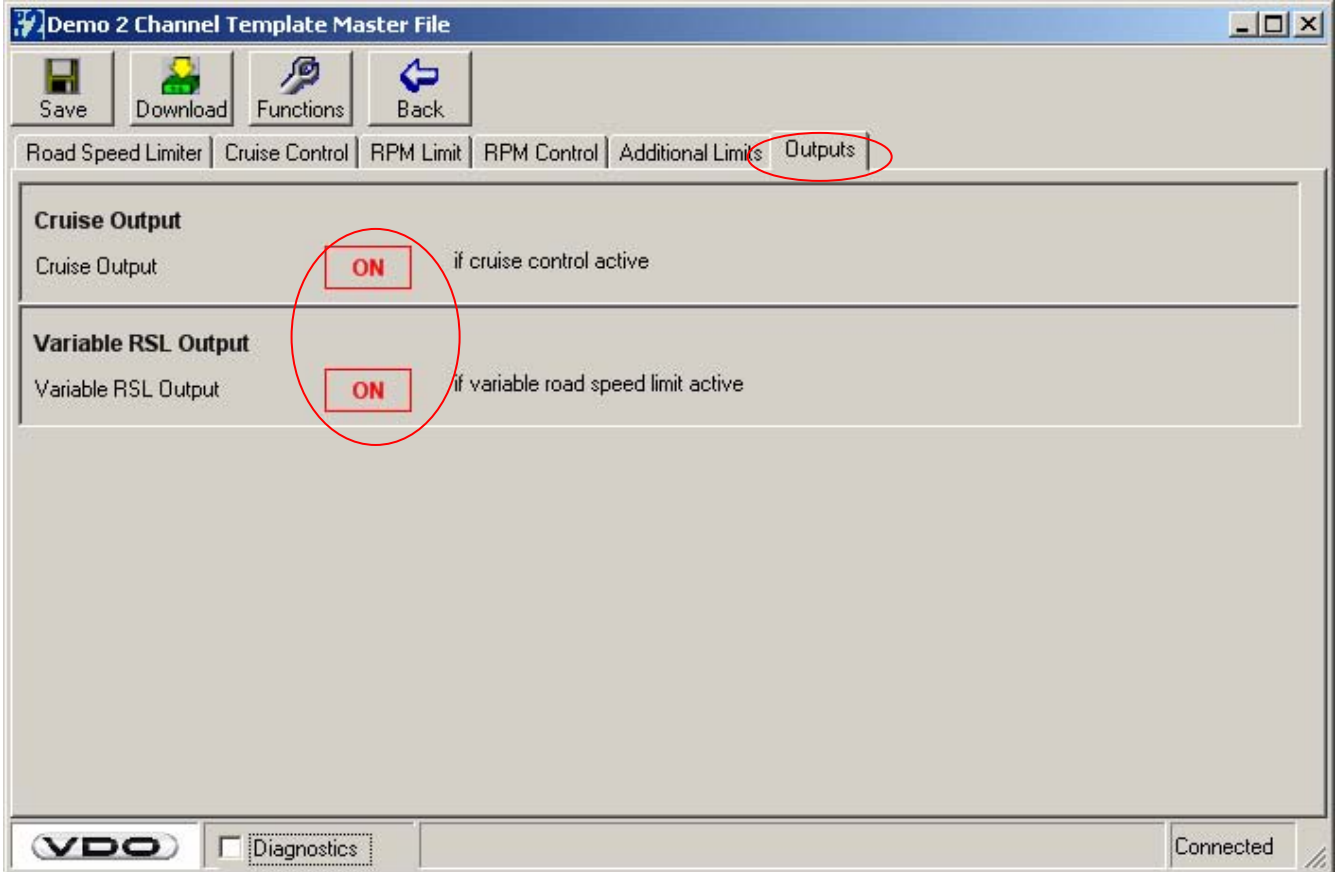

- Selection of when the outputs are active on or off.

Product Manual Pedal Interface II

3. Configuration Manager

3.4 Download and Storage of Vehicle-specific Data Set

After you have configured all specific data for vehicle, download and save your file / data set.

- 1 → Download the configured parameters to the Pedal Interface II control unit.
- 2 → The data sent to the VDO PI 2 should be stored on your PC (P2U. user file, see below).

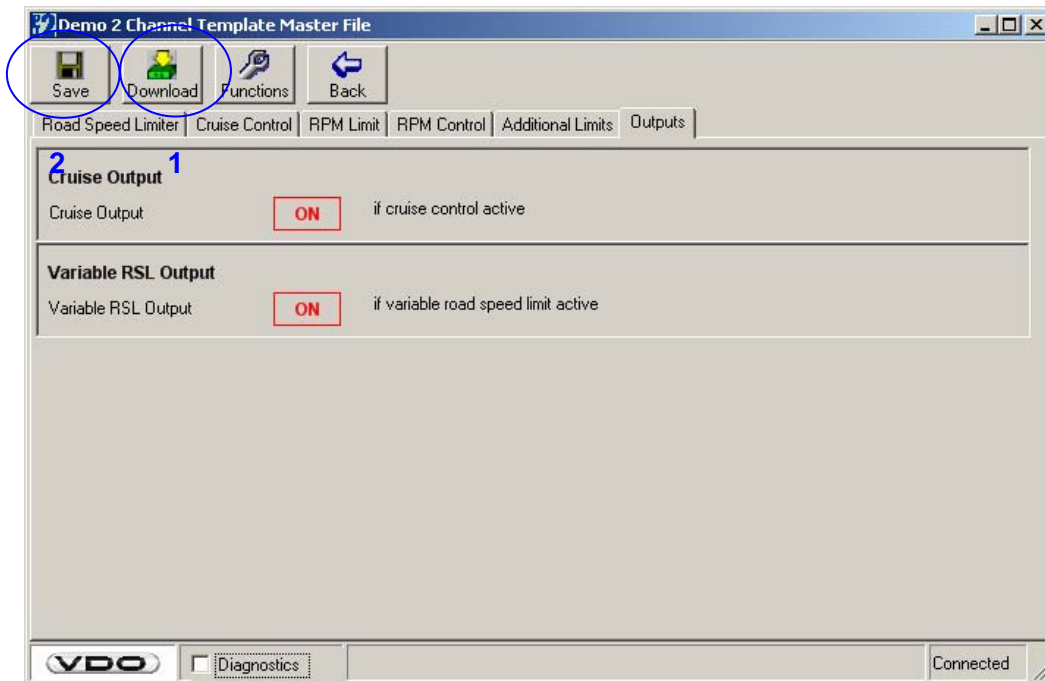

- 1 → Click on the "New" button to create a new variant file name (user file .P2U).

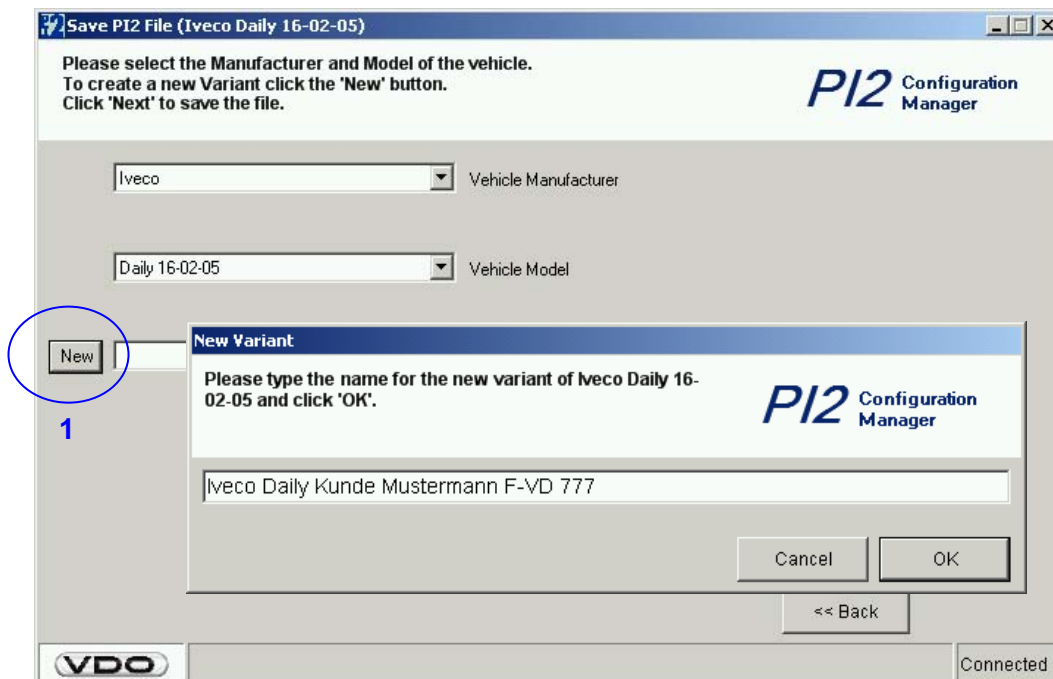

Product Manual Pedal Interface II

3. Configuration Manager

3.4 Download and Storage of Vehicle-specific Data Set

Click Next the file name will be stored as P2U user file.

Save P12 File (Iveco Daily 16-02-05 Iveco Daily Kunde Mustermann F-YD 777)

Please select the Manufacturer and Model of the vehicle.
To create a new Variant click the 'New' button.
Click 'Next' to save the file.

P12 Configuration Manager

Iveco Vehicle Manufacturer

Daily 16-02-05 Vehicle Model

New IVECO DAILY KUNDE MUSTERMANN F-VI Variant

<< Back Next >>

VDO Connected

Product Manual Pedal Interface II

3. Configuration Manager

3.5 Diagnostics Window

By ticking the diagnostics control box you can view the diagnostics window

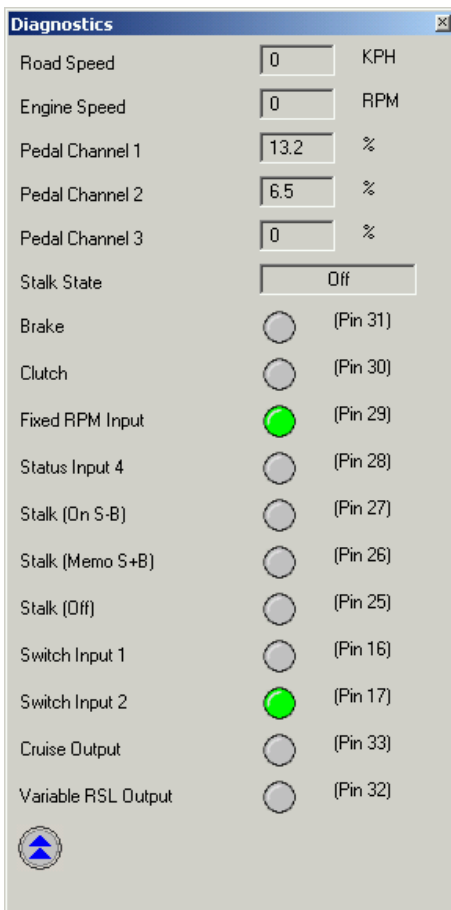
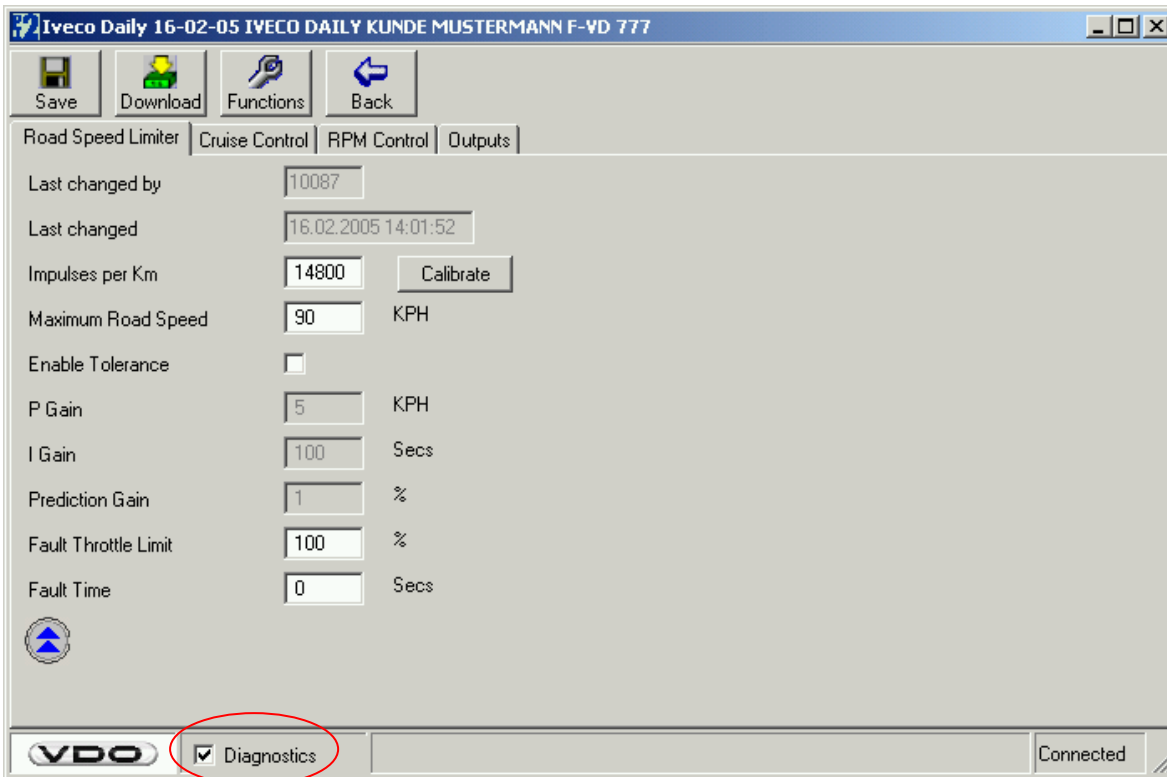

In the diagnostics window engine speed, road speed signal and pedal values are displayed

There is again the possibility to check all programmed inputs and outputs.

Active signal are displayed green.

Product Manual Pedal Interface II

4. Specifications

Contents

4.1 Technical Data	2
4.2 Inputs and Outputs	3

Product Manual Pedal Interface II

4. Specifications

4.1 Technical Data

Data	Control Electronic	Wiring harness	Remote Control	Dongle
General	Inverse polarity and overload protection.	B 0,5 acc. to DIN 72551	Two-filament interface, serial.	Connection to USB PC.
Electrical data	Nominal voltage: 12V and 24V. Operating voltage: 8V to 32V. Power consumption at 12V and 24V: T.15 < 1 mA, Cl.30 < 80 mA. When T. 15 switched off, current flow < 10 mA via T. 30.	Maximum load: 5A.		
Operating temperature	-40°C to + 85° acc. to IEC 68-2-38	-40°C to + 105°C	-40°C to + 85°C	0°C to +50°C
Protection class	IP 44, Mount inside vehicle.	Plug connection at section point Pedal: IP65.	Only for the use in protected environment.	Only for the use in protected environment.
<u>Test specifications:</u> Low and high temperature: Random vibration test within temperature cycle: Thermic Shock: Temperature and Humidity: Temperature cycle:	<ul style="list-style-type: none"> - ISO 16750 Part 4 chapter 5.1.1.2 and 5.1.2.2 - BS EN 60068-2: 1993 test Ab - BS EN 60068-2: 1993 test Bb <ul style="list-style-type: none"> - ISO 16750-3: 2003 (E) - Mechanical load - IEC 68-2-64: 1993, random vibrations: Method 2 - BS EN 60068-2-14: 2000 test Nb, Environmental test. <ul style="list-style-type: none"> - ISO 16750 Part 4 chapter 5.3.3 - BS EN 60068-2-14: 2000 test Na <ul style="list-style-type: none"> - ISO 16750 Part 4 chapter 5.6.2 - BS EN 60068-2-38: 1999 <ul style="list-style-type: none"> - ISO 16750 part 4 chapter 5.3.2 - BS EN 60068-2-14: 2000 test Nb 			
EMC	EG directive 95/54 e1 024028			
Road Speed limiter	EG directive 92/24 e1 000129 (only Enhanced and Premium)			

Product Manual Pedal Interface II

4. Specifications

4.2 Inputs and Outputs

Pin No.	Function	Inputs/Outputs	Signal type	Active level	Technical data
1	1 P+ engine ECU	Input	Analogue	Positive	$> 3V \leq 6V$ (5V)
2	1 PS Engine ECU	Output	Analogue	Positive controlled	From 1P+ ECU
3	1 P- Engine ECU	Input	Analogue	Negative	0V
4	2 P+ Engine ECU	Input	Analogue	Positive	$> 3V \leq 6V$ (5V)
5	2 PS Engine ECU	Output	Analogue	Positive controlled	Von 2P+ ECU
6	2 P- Engine ECU	Input	Analogue	Negative	0V
7	3 P+ Engine ECU	Input	Analogue	Positive	$> 3V \leq 6V$ (5V)
	Idle switch Engine ECU	Output	Digital	Positive or Negative	
8	3 PS Engine ECU	Output	Analogue	Positive controlled	From 3P+ ECU
	Upper switch Engine ECU	Output	Digital	Positive or Negative	
9	3 P- Engine ECU	Input	Analogue	Negative	0V
10	1 P+ Pedal	Output	Analogue	Positive	$> 3.5V \leq 4.9V$
11	1 PS Pedal	Input	Analogue	Positive controlled	From 1P+ Pedal
12	1 P- Pedal	Output	Analogue	Negative	0V
13	2 P+ Pedal	Output	Analogue	Positive	$> 3.5V \leq 4.9V$
14	2 PS Pedal	Input	Analogue	Positive controlled	From 2P+ Pedal
15	2 P- Pedal	Output	Analogue	Negative	0V
16	3 P+ Pedal	Output	Analogue	Positive	$3.5V \leq 4.9V$ or Signal Idle switch
	Idle-switch Pedal	Input	Digital	Negative	
17	3 PS Pedal	Input	Analogue	Positive controlled	From 3P+ Pedal Signal Upper-switch
	Upper-switch Pedal	Input	Digital	Negative	
18	3 P- Pedal	Output	Analogue	Negative	0V
19	+ U Batt 12V / 24V	Input	Digital	Positive	Clamp 30 Min. 8V, max. 32V Max. 80mA

Product Manual Pedal Interface II

4. Specifications

4.2 Inputs and Outputs

Pin No.	Function	Input/Output	Signal Type	Active level	Technical Data
20	Ground control unit Ground remote control	Input	Digital	Negative	Vehicle load
21	Engine Speed or road speed signal	Input	Frequency	Rectangle/Sinus	460- 300000 Imp./km Min. 0.8V, max. 50V Rin 560kΩ to ground
22	Speed or engine speed signal	Input	Frequency	Rectangle/ PWM/ Sinus	460- 300000 Imp./km Low level 0- 1.6V High level 6- 32V Rin 47kΩ to ground For tachograph Output B7/C3 (PWM)
23	Remote Control	Input / Output	Digital	Digital Data	
24	Ignition	Input	Digital	Positive	High level 7.35V-32V Low level 0V-3V Rin 47kΩ to ground
25	Status 7 In	Input	Digital	Positive or Negative	High level 7.35V-32V Low level 0V-3V Rin 47kΩ to ground
26	Status In	Input	Digital	Positive or Negative	High level 7.35V-32V Low level 0V-3V Rin 47kΩ to ground
27	Status 5 In	Input	Digital	Positive or Negative	High level 7.35V-32V Low level 0V-3V Rin 47kΩ to ground
28	Status 4 In	Input	Digital	Positive or Negative	High level 7.35V-32V Low level 0V-3V Rin 47kΩ to ground
29	Status 3 In	Input	Digital	Positive or Negative	High level 7.35V-32V Low level 0V-3V Rin 47kΩ to ground
30	Status 2 In	Input	Digital	Positive or Negative	High level 7.35V-32V Low level 0V-3V Rin 47kΩ to ground
31	Status 1 In	Input	Digital	Positive or Negative	High level 7.35V-32V Low level 0V-3V Rin 47kΩ to ground
32	Status 1 Out	Output	Digital	Negative	Max. 150mA
33	Status 2 Out	Output	Digital	Negative	Max. 150mA

Product Manual Pedal Interface II

5. Scope of Delivery

Contents

5.1 Pedal Interface II System:	2
5.2 Pedal Interface II Control electronic:	2
5.3 Wiring Harness	3
5.4 Mounting Kit	3
5.5 Handset for Engine Speed Control	3
5.6 Dongle Level 2 inclusive Testing software	4
5.7 Dongle Level 3 inclusive Testing software	4
5.8 Clutch Switch	4
5.9 Clutch Switch contact less	4
5.10 Standard Operating Stalk	5
5.11 LED Operating Stalk right	5
5.12 LED Operating Stalk left	5
5.13 Operating Stalk right, flexible	6
5.14 Operating Stalk left, flexible	6

Product Manual Pedal Interface II

5. Scope of Delivery

5.1 Pedal Interface II System:

Type 1 Standard - 3 Channel analogue
(cruise control®)
X10-737-100-001

Type 1 Enhanced - 3 Channel analogue
(cruise control® + speed and engine speed
limitation)
X10-737-101-001

Type 1 Premium - 3 Channel analogue
(cruise control® + speed and engine speed
limitation + engine speed control)
X10-737-102-001

Type 2 Standard - 2 Channel analogue + 2
switches
(cruise control®)
X10-737-200-001

Type 2 Enhanced - 2 Channel analogue + 2
switches
(cruise control® + speed and engine speed
limitation)
X10-737-201-001

Type 2 Premium - 2 Channel analogue + 2
switches
(cruise control® + speed and engine speed
limitation + engine speed control)
X10-737-202-001



5.2 Pedal Interface II Control electronic:

Type 1 Standard - 3 Channel analogue
(cruise control®)
X39-737-100-001

Type 1 Enhanced - 3 Channel analogue
(cruise control® + speed and engine speed
limitation)
X39-737-101-001

Type 1 Premium - 3 Channel analogue
(cruise control® + speed and engine speed
limitation + engine speed control)
X39-737-102-001

Type 2 Standard - 2 Channel analogue + 2
switches
(cruise control®)
X39-737-200-001

Type 2 Enhanced - 2 Channel analogue + 2
switches
(cruise control® + speed and engine speed
limitation)
X39-737-201-001

Type 2 Premium - 2 Channel analogue + 2
switches
(cruise control® + speed and engine speed
limitation + engine speed control)
X39-737-202-001



Product Manual Pedal Interface II

5. Scope of Delivery

5.3 Wiring Harness

X39-737-300-008



5.4 Mounting Kit

X39-737-300-003

Contents:

- 2 x clutch housing
- 2 x plug housing
- 4 x core seal
- 2 x interface seal
- 10 x coding pin
- 9 x pin contact
- 9 x socket contact
- 2 x cross-head screw
- 2 x fuse housing
- 2 x cap fuse housing
- 2 x fuse 1A
- 2 x contact bushing for fuse housing
- 10 x binder



5.5 Handset for Engine Speed Control

X39-737-003-003



Product Manual Pedal Interface II

5. Scope of Delivery

5.6 Dongle Level 2 inclusive Testing software

X12-737-100-002

Dongle for licensed garages acc. to EU guideline 92/6
Allows access to all functions incl. max. Road speed limitation.

5.7 Dongle Level 3 inclusive Testing software

X12-737-100-003

Dongle for not licensed garages acc. to EU guideline 92/6
Allows access to cruise control® - function and rotation speed control (fixed and variable rotation speed control as well as throttle position limitation).



5.8 Clutch Switch

X39-397-106-152

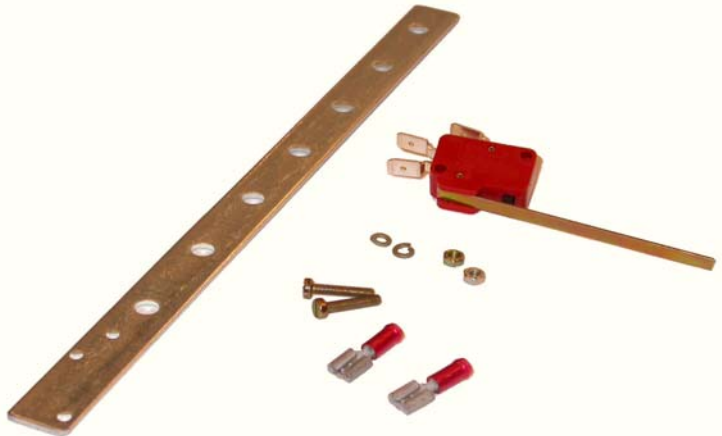

5.9 Clutch Switch contact less

X39-737-300-009



Product Manual Pedal Interface II

5. Scope of Delivery

5.10 Standard Operating Stalk

X39-397-106-149

Mounting kit for standard operating lever

X39-737-300-010



5.11 LED Operating Stalk right

X39-737-300-004



5.12 LED Operating Stalk left

X39-737-300-005



Product Manual Pedal Interface II

5. Scope of Delivery

5.13 Operating Stalk right, flexible

X39-737-300-006



5.14 Operating Stalk left, flexible

X39-737-300-007



Product-Manual Pedal Interface II

6. Type Approvals

Content

6.1 EC Type Approval 92/24	2
6.2 EC Type Approval 95/54	9

Product-Manual Pedal Interface II

6. Type Approvals

6.1 EC Type Approval 92/24



Kraftfahrt-Bundesamt
D-24932 Flensburg

EWG - TYPGENEHMIGUNGSBOGEN
(technische Einheit)

EEC TYPE-APPROVAL CERTIFICATE
(separate technical unit)

Benachrichtigung über

- **die Typgenehmigung**

eines Typs einer gesonderten technischen Einheit gemäß der Richtlinie 92/24/EWG zuletzt geändert durch die Richtlinie 2004/11/EG über Geschwindigkeitsbegrenzungseinrichtungen oder vergleichbare Geschwindigkeitsbegrenzungssysteme für bestimmte Kraftfahrzeugklassen.

Communication concerning the

- **type-approval**

of a type of separate technical unit with regard to Directive 92/24/EEC as last amended by Directive 2004/11/EC relating to speed limitation devices or similar speed limitation on-board systems of certain categories of motor vehicles.

Typgenehmigungsnummer: **e1*92/24*2004/11*0129*00**

Type-approval No.:

TEIL I
SECTION I

0. Allgemeines
General

0.1. Fabrikmarke (Firmenbezeichnung des Herstellers):
Make (trade name of manufacturer):
Siemens VDO Trading

0.2. Typ
Type
VDO Pedal Interface II

und Handelsbezeichnung:
and commercial description:
VDO Pedal Interface II
VDO Pedal Interface II Enhanced
VDO Pedal Interface II Premium

Product-Manual Pedal Interface II

6. Type Approvals



Kraftfahrt-Bundesamt

D-24932 Flensburg

2

Nummer der Genehmigung: e1*92/24*2004/11*0129*00
Approval No.:

- 0.3. Typenkennermerkmale, sofern auf der gesonderten technischen Einheit vorhanden:
Means of identification of type, if marked on the technical unit:
X 39-737-101-???; **X 39-737-102-???**;
X 39-737-201-???; **X 39-737-202-???**
- 0.3.1. Anbringungsstelle dieser Kennmerkmale:
Location of that marking:
auf dem Gehäuse
on the housing
- 0.5. Name und Anschrift des Herstellers:
Name and address of manufacturer:
Siemens VDO Trading GmbH
DE-60388 Frankfurt am Main
- 0.7. Im Fall von Bauteilen und technischen Einheiten:
Anbringungsstelle und Anbringungsart des EWG-Typgenehmigungszeichens:
In the case of components and separate technical units, location and method of affixing
of the EEC-approval mark:
Klebeschild auf der Frontseite des Elektronikgehäuses
stick-on-label on the front side of the housing

TEIL II SECTION II

1. Zusätzliche Angaben:
Additional information:
- 1.1. Geschwindigkeitsbegrenzungseinrichtung:
Speed limitation device:
elektronisch
electronic
- 1.2. Fahrzeugtyp(en), in den (die) die Einrichtung eingebaut werden kann:
Vehicle type(s) on which the device may be installed:
Klassen M₁, M₂, M₃, N₁, N₂ und N₃ mit elektronischer Pedalübertragung
classes M₁, M₂, M₃, N₁, N₂ and N₃ with electronic pedal transmission
- 1.3. Geschwindigkeit oder Bereich der Geschwindigkeiten, auf die der Begrenzer innerhalb
der Spanne der (des) Fahrzeuge(s), für den die Einrichtung vorgesehen ist, eingestellt
werden kann:
Speed or range of speeds at which the limiter may be set within the range established
for vehicle(s) on which the device may be installed:
30 km/h bis/to 200 km/h

Product-Manual Pedal Interface II

6. Type Approvals



Kraftfahrt-Bundesamt

D-24932 Flensburg

3

Nummer der Genehmigung: e1*92/24*2004/11*0129*00
Approval No.:

- 1.4. Motorleistung im Verhältnis zur Leermasse der (des) Fahrzeuge(s), in das (die) die Einrichtung eingebaut werden kann:
Engine power to unladen mass ratio of the vehicle(s) on which the device may be installed:
max. 50 KW/t
- 1.5. Größtes Verhältnis der Motordrehzahl zur Fahrzeuggeschwindigkeit im höchsten Gang des Fahrzeugs/der Fahrzeuge in das (die) die Einrichtung eingebaut werden kann:
Highest ratio of engine speed to vehicle speed in top gear of vehicle(s) on which the device may be installed:
entfällt
not applicable
- 1.6. Anleitungen zum Einbau der Einrichtung für jeden Fahrzeugtyp:
Instructions for the installation of the device for each type of vehicle:
Die Einrichtung wird vom Gerätehersteller oder von einer autorisierten Fachwerkstatt eingebaut.
The device is installed by the manufacturer of the device or by an authorised garage.
2. Für die Durchführung der Prüfungen zuständige Prüfstelle:
Technical department responsible for carrying out the tests:
TÜV Technische Überwachung Hessen GmbH
DE-64285 Darmstadt
3. Datum des Prüfprotokolls:
Date of test report:
25.11.2004
4. Nummer des Prüfprotokolls:
Number of test report:
TÜH 92/24 - 005.00
5. Grund (Gründe) für die Erweiterung der Typgenehmigung (falls zutreffend):
Ground(s) for extending type-approval (where appropriate):
entfällt
not applicable
6. Bemerkungen (ggf.):
Comments (if any):
entfällt
not applicable

Product-Manual Pedal Interface II

6. Type Approvals



Kraftfahrt-Bundesamt
D-24932 Flensburg

4

Nummer der Genehmigung: e1*92/24*2004/11*0129*00
Approval No.:

7. Ort: **DE-24932 Flensburg**
Place:
8. Datum: **14.12.2004**
Date:
9. Unterschrift: **Im Auftrag**
Signature:



Detlef Hansen

10. Eine Liste der in der Typpenehmigungsakte enthaltenen Dokumente, die bei der Verwaltungsbehörde, die die Typpenehmigung erteilt hat, hinterlegt ist, liegt bei. Sie können auf Antrag eingesehen werden.
A list of documents making up the type-approval file lodged with the administrative department that has granted type-approval, which may be obtained on request, is attached.
1. Inhaltsverzeichnis zu den Beschreibungsunterlagen
Index to the information package
 2. Beschreibungsunterlagen
Information package

Product-Manual Pedal Interface II

6. Type Approvals



Kraftfahrt-Bundesamt

D-24932 Flensburg

Inhaltsverzeichnis zu den Beschreibungsunterlagen Index to the information package

Anlage 1 zur EWG-Typgenehmigung Nr.: **e1*92/24*2004/11*0129*00**
Enclosure 1 to EEC type-approval certificate No.:

Ausgabedatum: **14.12.2004**
Date of issue:

letztes Änderungsdatum: --
last date of amendment:

1. Nebenbestimmungen und Rechtsbehelfsbelehrung
By-clauses and informations to legal remedy

2. Beschreibungsbogen Nr.:
Information document No.:
PRC04-001; 10-04

Datum:
Date:
28.10.2004

letztes Änderungsdatum: --
last date of amendment:

3. Prüfbericht(e) Nr.:
Test report(s) No.:
TÜH 92/24 - 005.00

Datum:
Date:
25.11.2004

4. Beschreibung der Änderungen:
Description of the modifications:
entfällt
not applicable

Product-Manual Pedal Interface II

6. Type Approvals



Kraftfahrt-Bundesamt

D-24932 Flensburg

Nr. der Genehmigung: e1*92/24*2004/11*0129*00
Approval No.:

- Anlage -

Nebenbestimmungen und Rechtsbehelfsbelehrung

Nebenbestimmungen

Jede Einrichtung, die dem genehmigten Typ entspricht, ist gemäß der angewendeten Vorschrift zu kennzeichnen.

Das Genehmigungszeichen lautet wie folgt:

e1

000129

Die Einzelerzeugnisse der reihenweisen Fertigung müssen mit den Genehmigungsunterlagen genau übereinstimmen. Änderungen an den Einzelerzeugnissen sind nur mit ausdrücklicher Zustimmung des Kraftfahrt-Bundesamtes gestattet.

Änderungen der Firmenbezeichnung, der Anschrift und der Fertigungsstätten sowie eines bei der Erteilung der Genehmigung benannten Zustellungsbevollmächtigten oder bevollmächtigten Vertreters sind dem Kraftfahrt-Bundesamt unverzüglich mitzuteilen.

Verstöße gegen diese Bestimmungen können zum Widerruf der Genehmigung führen und können überdies strafrechtlich verfolgt werden.

Die Genehmigung erlischt, wenn sie zurückgegeben oder entzogen wird, oder der genehmigte Typ den Rechtsvorschriften nicht mehr entspricht. Der Widerruf kann ausgesprochen werden, wenn die für die Erteilung und den Bestand der Genehmigung geforderten Voraussetzungen nicht mehr bestehen, wenn der Genehmigungsinhaber gegen die mit der Genehmigung verbundenen Pflichten – auch soweit sie sich aus den zu dieser Genehmigung zugeordneten besonderen Auflagen ergeben - verstößt oder wenn sich herausstellt, dass der genehmigte Typ den Erfordernissen der Verkehrssicherheit oder des Umweltschutzes nicht entspricht.

Das Kraftfahrt-Bundesamt kann jederzeit die ordnungsgemäße Ausübung der durch diese Genehmigung verliehenen Befugnisse, insbesondere die genehmigungsgerechte Fertigung, nachprüfen. Es kann zu diesem Zweck nach den Regeln der zugrundeliegenden Vorschriften Proben entnehmen oder entnehmen lassen.

Die mit der Erteilung der Genehmigung verliehenen Befugnisse sind nicht übertragbar. Schutzrechte Dritter werden durch diese Genehmigung nicht berührt.

Rechtsbehelfsbelehrung

Gegen diese Genehmigung kann innerhalb eines Monats nach Bekanntgabe Widerspruch erhoben werden. Der Widerspruch ist beim **Kraftfahrt-Bundesamt, Fördestraße 16, DE-24944 Flensburg**, schriftlich oder zur Niederschrift einzulegen.

Product-Manual Pedal Interface II

6. Type Approvals



Kraftfahrt-Bundesamt

D-24932 Flensburg

2

Nummer der Genehmigung: e1*92/24*2004/11*0129*00
Approval No.:

- Attachment -

Collateral clauses and instruction on right to appeal

Collateral clauses

All equipment which corresponds to the approved type is to be identified according to the applied regulation.

The approval identification is as follows: - see German version -

The individual production of serial fabrication must be in exact accordance with the approval documents. Changes in the individual production are only allowed with express consent of the Kraftfahrt-Bundesamt.

Changes in the name of the company, the address and the manufacturing plant as well as one of the parties given the authority to delivery or authorised representative named when the approval was granted is to be immediately disclosed to the Kraftfahrt-Bundesamt.

Breach of this regulation can lead to recall of the approval and moreover can be legally prosecuted.

The approval expires if it is returned or withdrawn or if the type approved no longer complies with the legal requirements. The revocation can be made if the demanded requirements for issuance and the continuance of the approval no longer exist, if the holder of the approval violates the duties involved in the approval, also to the extent that they result from the assigned conditions to this approval, or if it is determined that the approved type does not comply with the requirements of traffic safety or environmental protection.

The Kraftfahrt-Bundesamt can at any time check the proper exercise of the conferred authority taken from this approval, in particular the approving standards. For this purpose, samples can be taken or have taken according to the rules of the underlying regulations.

The conferred authority contained with issuance of this approval is not transferable. Trade mark rights of third parties are not affected with this approval.

Instruction on right to appeal

This approval can be appealed within one month after notification. The appeal is to be filed in writing or as a transcript at the **Kraftfahrt-Bundesamt, Fördestraße 16, DE-24944 Flensburg.**

Product-Manual Pedal Interface II

6. Type Approvals

6.2 EC Type Approval 95/54



Kraftfahrt-Bundesamt

D-24932 Flensburg

EG-TYPGENEHMIGUNGSBOGEN EC TYPE-APPROVAL CERTIFICATE

Benachrichtigung über

- die Typgenehmigung

für ein Bauteil gemäß der Richtlinie 72/245/EWG, zuletzt geändert durch die Richtlinie 95/54/EG

Communication concerning the

- type-approval

of a type of component with regard to Directive 72/245/EEC, as last amended by Directive 95/54/EC

Typgenehmigungsnummer: **e1*72/245*95/54*4028*00**
Type-approval No.:

Grund für die Erweiterung:

Reason for extension:

entfällt

not applicable

ABSCHNITT I SECTION I

0.1. Fabrikmarke (Handelsname des Herstellers):
Make (trade name of manufacturer):
Siemens VDO Trading

0.2. Typ:
Type:
VDO Pedal Interface II

Handelsbezeichnung(en):
General commercial description(s):
VDO Pedal Interface II Standard
VDO Pedal Interface II Enhanced
VDO Pedal Interface II Premium

Product-Manual Pedal Interface II

6. Type Approvals



Kraftfahrt-Bundesamt

D-24932 Flensburg

2

Nummer der Genehmigung: e1*72/245*95/54*4028*00
Approval No.:

- 0.3. Merkmale zur Typidentifizierung, sofern am Bauteil vorhanden:
Means of identification of type, if marked on the component:
X 39-737-100-????; X 39-737-101-????;
X 39-737-102-????; X 39-737-200-????;
X 39-737-201-????; X 39-737-202-????
- 0.3.1. Anbringungsstelle dieser Merkmale:
Location of that marking:
auf dem Gehäuse
on the housing
- 0.4. Fahrzeugklasse:
Category of vehicle:
entfällt
not applicable
- 0.5. Name und Anschrift des Herstellers:
Name and address of manufacturer:
Siemens VDO Trading GmbH
DE-60388 Frankfurt am Main
- 0.7. Bei Bauteilen und selbständigen technischen Einheiten, Lage und Anbringungsart des EG-Genehmigungszeichens:
In the case of components and separate technical units, location and method of affixing of the EEC approval-mark:
Klebeschild auf der Frontseite des Gehäuses
stick-on-label on the front side of the housing
- 0.8. Anschrift(en) der Fertigungsstätte(n):
Address(es) of assembly plant(s):
Siemens VDO Trading AG
CH-9464 Rüthi

ABSCHNITT II SECTION II

1. Zusätzliche Angaben (erforderlichenfalls):
Additional information (where applicable):
siehe Anlage
see appendix
2. Für die Durchführung der Prüfungen zuständiger technischer Dienst:
Technical service responsible for carrying out the tests:
VDE-Prüf- und Zertifizierungsinstitut
DE-63069 Offenbach

Product-Manual Pedal Interface II

6. Type Approvals



Kraftfahrt-Bundesamt
D-24932 Flensburg

3

Nummer der Genehmigung: e1*72/245*95/54*4028*00
Approval No.:

3. Datum des Prüfprotokolls:
Date of test report:
10.11.2004
4. Nummer des Prüfprotokolls:
Number of test report:
1283500-3650-0009/45816
5. Gegebenenfalls Bemerkungen:
Remarks (if any):
siehe Anlage
see appendix
6. Ort: **DE-24932 Flensburg**
Place:
7. Datum: **25.11.2004**
Date:
8. Unterschrift: **Im Auftrag**
Signature:

Detlef Hansen



Product-Manual Pedal Interface II

6. Type Approvals



Kraftfahrt-Bundesamt

D-24932 Flensburg

4

Nummer der Genehmigung: e1*72/245*95/54*4028*00
Approval No.:

9. Das Inhaltsverzeichnis der bei den zuständigen Behörden hinterlegten Typgenehmigungsunterlagen, die auf Antrag erhältlich sind, liegt bei.
The index to the information package lodged with the approval authority, which may be obtained on request is attached.
1. Anlage zum EG-Typgenehmigungsbogen
Appendix to the EC type-approval certificate
 2. Inhaltsverzeichnis zu den Beschreibungsunterlagen
Index to the information package
 3. Beschreibungsunterlagen
Information package

Product-Manual Pedal Interface II

6. Type Approvals



Kraftfahrt-Bundesamt

D-24932 Flensburg

Anlage Appendix

zum EWG-Typgenehmigungsbogen Nr. **e1*72/245*95/54*4028*00**
betreffend die Typgenehmigung einer elektrischen/elektronischen Unterbaugruppe gemäß
der Richtlinie 72/245/EWG, zuletzt geändert durch die Richtlinie 95/54/EG
to EEC type-approval certificate No. **e1*72/245*95/54*4028*00**
concerning the type-approval of an electric/electronic sub-assembly with regard to Directive
72/245/EEC, as last amended by Directive 95/54/EC

1. Ergänzende Angaben:
Additional information:
 - 1.1. Nennspannung des elektrischen Systems:
Electric system rated voltage:
12 V bzw. - resp. 24 V
 - 1.2. Dieses Bauteil kann für jeden Fahrzeugtyp mit folgenden Einschränkungen
verwendet werden:
This component can be used on any vehicle type with the following restrictions:
**alle Fahrzeugtypen mit einem 12 V bzw. 24 V - Bordnetz und Batterie(-) an der
Karosserie**
**any vehicle types with an 12 V resp. 24 V - electrical wiring and battery(-) at
the body**
 - 1.2.1. Einbauvorschriften (gegebenenfalls):
Installation conditions, if any:
die Einbauvorschriften sind der Einbauanleitung zu entnehmen
**the installation conditions have to be gathered from the installation
instructions**
 - 1.3. Diese selbständige technische Einheit kann nur für die folgenden Fahrzeugtypen
verwendet werden:
This ESA can only be used on the following vehicle types:
entfällt
not applicable
 - 1.3.1. Einbauvorschriften (gegebenenfalls):
Installation conditions, if any:
entfällt
not applicable

Product-Manual Pedal Interface II

6. Type Approvals



Kraftfahrt-Bundesamt

D-24932 Flensburg

2

Nummer der Genehmigung: e1*72/245*95/54*4028*00

Approval No.:

- 1.4. Angewandte(s) spezielle(s) Prüfverfahren und Frequenzbereiche zur Ermittlung der Störfestigkeit:
The specific test method(s) used and the frequency ranges covered to determine immunity were:
siehe Prüfbericht Nr.: 1283500-3650-0009/45816 vom 10.11.2004
see technical report

- 1.5. Beauftragtes/anerkanntes Labor (für die Zwecke dieser Richtlinie), zuständig für die Durchführung der Prüfungen:
Approved/recognized laboratory (for the purpose of this Directive) responsible for carrying out the tests:
VDE-Prüf- und Zertifizierungsinstitut
DE-63069 Offenbach

5. Bemerkungen:
Remarks:
entfällt
not applicable

Product-Manual Pedal Interface II

6. Type Approvals



Kraftfahrt-Bundesamt

D-24932 Flensburg

Inhaltsverzeichnis zu den Beschreibungsunterlagen Index to the information package

Zum EWG-Typgenehmigungsbogen Nr.: e1*72/245*95/54*4028*00
To EEC approval certificate No.:

Ausgabedatum: **25.11.2004**
Date of issue:

letztes Änderungsdatum: --
last date of amendment:

1. Nebenbestimmungen und Rechtsbehelfsbelehrung
By-clauses and informations to legal remedy

2. Beschreibungsbogen Nr.:
Information document No.:
PRC04-001; 10-04

Datum:
Date:
03.11.2004

letztes Änderungsdatum: ~
last date of amendment:

3. Prüfbericht(e) Nr.:
Test report(s) No.:
1283500-3650-0009/45816

Datum:
Date:
10.11.2004

4. Beschreibung der Änderungen:
Description of the modifications:
entfällt
not applicable

Product-Manual Pedal Interface II

6. Type Approvals



Kraftfahrt-Bundesamt

D-24932 Flensburg

Nr. der Genehmigung: e1*72/245*95/54*4028*00
Approval No.:

- Anlage -

Nebenbestimmungen und Rechtsbehelfsbelehrung

Nebenbestimmungen

Jede Einrichtung, die dem genehmigten Typ entspricht, ist gemäß der angewendeten Vorschrift zu kennzeichnen.

Das Genehmigungszeichen lautet wie folgt:

e1

024028

Die Einzelerzeugnisse der reihenweisen Fertigung müssen mit den Genehmigungsunterlagen genau übereinstimmen. Änderungen an den Einzelerzeugnissen sind nur mit ausdrücklicher Zustimmung des Kraftfahrt-Bundesamtes gestattet.

Änderungen der Firmenbezeichnung, der Anschrift und der Fertigungsstätten sowie eines bei der Erteilung der Genehmigung benannten Zustellungsbevollmächtigten oder bevollmächtigten Vertreters sind dem Kraftfahrt-Bundesamt unverzüglich mitzuteilen.

Verstöße gegen diese Bestimmungen können zum Widerruf der Genehmigung führen und können überdies strafrechtlich verfolgt werden.

Die Genehmigung erlischt, wenn sie zurückgegeben oder entzogen wird, oder der genehmigte Typ den Rechtsvorschriften nicht mehr entspricht. Der Widerruf kann ausgesprochen werden, wenn die für die Erteilung und den Bestand der Genehmigung geforderten Voraussetzungen nicht mehr bestehen, wenn der Genehmigungsinhaber gegen die mit der Genehmigung verbundenen Pflichten – auch soweit sie sich aus den zu dieser Genehmigung zugeordneten besonderen Auflagen ergeben - verstößt oder wenn sich herausstellt, dass der genehmigte Typ den Erfordernissen der Verkehrssicherheit oder des Umweltschutzes nicht entspricht.

Das Kraftfahrt-Bundesamt kann jederzeit die ordnungsgemäße Ausübung der durch diese Genehmigung verliehenen Befugnisse, insbesondere die genehmigungsgerechte Fertigung, nachprüfen. Es kann zu diesem Zweck nach den Regeln der zugrundeliegenden Vorschriften Proben entnehmen oder entnehmen lassen.

Die mit der Erteilung der Genehmigung verliehenen Befugnisse sind nicht übertragbar. Schutzrechte Dritter werden durch diese Genehmigung nicht berührt.

Rechtsbehelfsbelehrung

Gegen diese Genehmigung kann innerhalb eines Monats nach Bekanntgabe Widerspruch erhoben werden. Der Widerspruch ist beim **Kraftfahrt-Bundesamt, Fördestraße 16, DE-24944 Flensburg**, schriftlich oder zur Niederschrift einzulegen.

Product-Manual Pedal Interface II

6. Type Approvals



Kraftfahrt-Bundesamt

D-24932 Flensburg

2

Nummer der Genehmigung: e1*72/245*95/54*4028*00
Approval No.:

- Attachment -

Collateral clauses and instruction on right to appeal

Collateral clauses

All equipment which corresponds to the approved type is to be identified according to the applied regulation.

The approval identification is as follows: - see German version -

The individual production of serial fabrication must be in exact accordance with the approval documents. Changes in the individual production are only allowed with express consent of the Kraftfahrt-Bundesamt.

Changes in the name of the company, the address and the manufacturing plant as well as one of the parties given the authority to delivery or authorised representative named when the approval was granted is to be immediately disclosed to the Kraftfahrt-Bundesamt.

Breach of this regulation can lead to recall of the approval and moreover can be legally prosecuted.

The approval expires if it is returned or withdrawn or if the type approved no longer complies with the legal requirements. The revocation can be made if the demanded requirements for issuance and the continuance of the approval no longer exist, if the holder of the approval violates the duties involved in the approval, also to the extent that they result from the assigned conditions to this approval, or if it is determined that the approved type does not comply with the requirements of traffic safety or environmental protection.

The Kraftfahrt-Bundesamt can at any time check the proper exercise of the conferred authority taken from this approval, in particular the approving standards. For this purpose, samples can be taken or have taken according to the rules of the underlying regulations.

The conferred authority contained with issuance of this approval is not transferable. Trade mark rights of third parties are not affected with this approval.

Instruction on right to appeal

This approval can be appealed within one month after notification. The appeal is to be filed in writing or as a transcript at the **Kraftfahrt-Bundesamt, Fördestraße 16, DE-24944 Flensburg.**

Pedal Interface II

Datenblätter | Data Sheets



www.siemensvdo.com

Universelle Anlagen

Systemkomponente für Pedal Interface II

Universal Systems

System component for Pedal Interface II

Die Anlage besteht aus:

The system is consisting of:

Pos.	Komponente / Components Typ 1 — 3 Kanal analog / Type 1 — 3 Channel analogue	Anlage/System		
		Standard	Enhanced	Premium
1	Regelelektronik Typ 1 (tempostat®) Electronic controller type 1 (Cruise Control)	X		
1	Regelelektronik Typ 1 (tempostat® + Geschwindigkeits- u. Drehzahlbegrenzung) Electronic controller type 1 (Cruise Control + Road speed limiter + Engine Speed Limiter)		X	
1	Regelelektronik Typ 1 (tempostat® + Geschwindigkeits- u. Drehzahlbegrenzung + Drehzahlregelung) / (Cruise Control + Road speed limiter + Engine Speed Limiter + Engine speed Controller)			X
2	Einbausatz / Installation kit	X	X	X
3	Kabelbaum / Wiring harness	X	X	X
4	Bedienungsanleitung / Operating Instructions	X	X	X

Pos.	Komponente / Components Typ 2 — 2 Kanal analog + 2 Schalter Type 2 — 2 Channel analogue+ 2 switches	Anlage/System		
		Standard	Enhanced	Premium
1	Regelelektronik Typ 2 (tempostat®) Electronic controller type 2 (Cruise Control)	X		
1	Regelelektronik Typ 2 (tempostat® + Geschwindigkeits- u. Drehzahlbegrenzung) Electronic controller type 2 (Cruise Control + Road speed limiter + Engine Speed Limiter)		X	
1	Regelelektronik Typ 2 (tempostat® + Geschwindigkeits- u. Drehzahlbegrenzung + Drehzahlregelung) / (Cruise Control + Road speed limiter + Engine Speed Limiter + Engine speed Controller)			X
2	Einbausatz / Installation kit	X	X	X
3	Kabelbaum / Wiring harness	X	X	X
4	Bedienungsanleitung / Operating Instructions	X	X	X

Bestell-Nr. / Order No:

Typ 1 / Type 1 Standard	3 Kanal analog (tempostat®) 3 Channel analogue (Cruise Control)	X10-737-100-001
Typ 1 / Type 1 Enhanced	3 Kanal analog (tempostat® + Geschwindigkeits- u. Drehzahlbegrenzung) 3 Channel analogue (Cruise Control + Road speed limiter + Engine Speed Limiter)	X10-737-101-001
Typ 1 / Type 1 Premium	3 Kanal analog (tempostat® + Geschwindigkeits- u. Drehzahlbegrenzung + Drehzahlregelung) 3 Channel analogue (Cruise Control + Road speed limiter + Engine Speed Limiter + Engine speed Controller)	X10-737-102-001
Typ 2 / Type 2 Standard	2 Kanal analog + 2 Schalter (tempostat®) 2 Channel analogue + 2 switches (Cruise Control)	X10-737-200-001
Typ 2 / Type 2 Enhanced	2 Kanal analog + 2 Schalter (tempostat® + Geschwindigkeits- u. Drehzahlbegrenzung) 2 Channel analogue + 2 switches (Cruise Control + Road speed limiter + Engine Speed Limiter)	X10-737-201-001
Typ 2 / Type 2 Premium	2 Kanal analog + 2 Schalter (tempostat® + Geschwindigkeits- u. Drehzahlbegrenzung + Drehzahlregelung) 2 Channel analogue + 2 switches (Cruise Control + Road speed limiter + Engine Speed Limiter + Engine speed Controller)	X10-737-202-001

Regelelektronik

Systemkomponente für
Pedal Interface II

Electronic Controller

System component for
Pedal Interface II

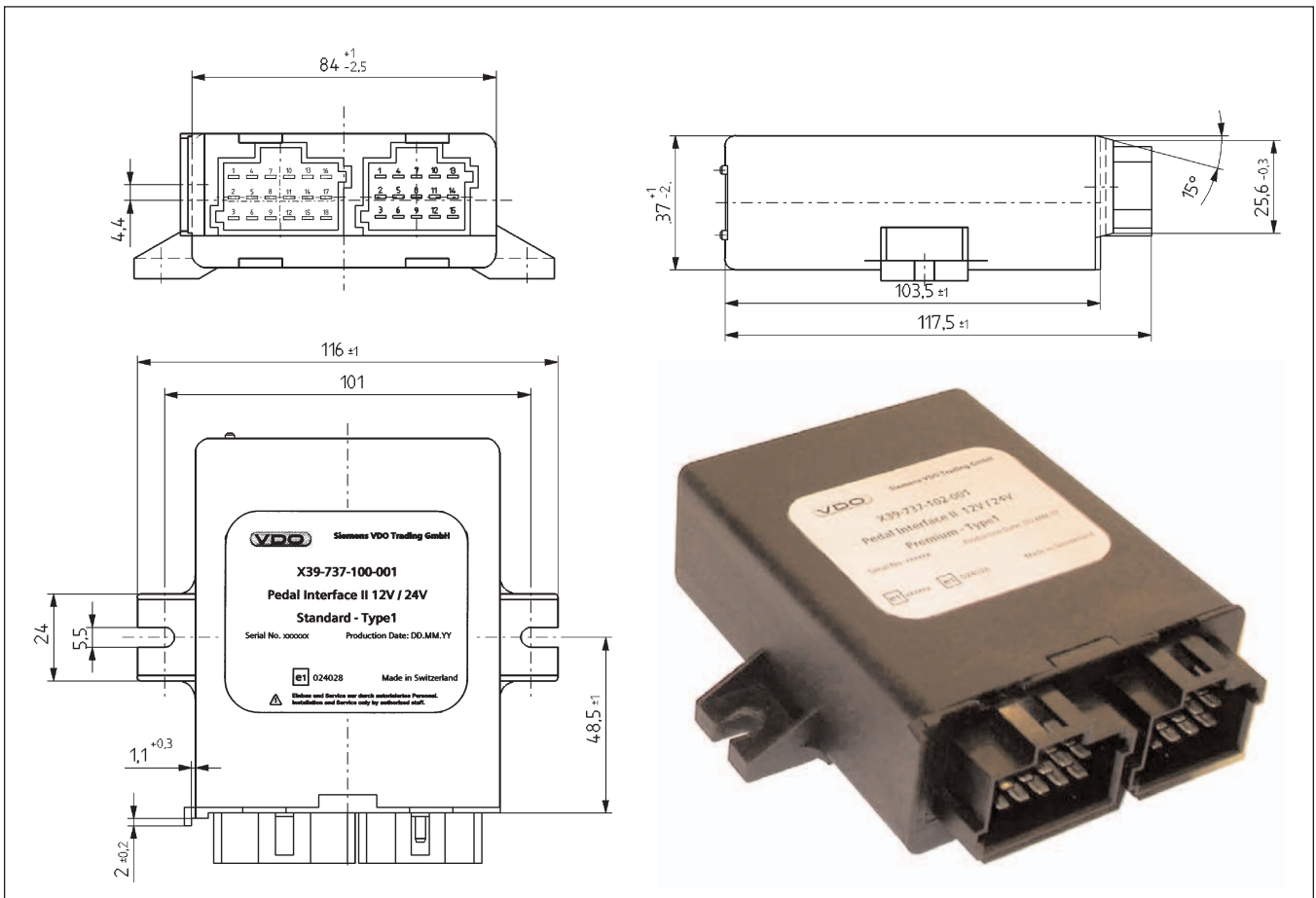

Bestell-Nr. / Order No:

Typ 1 / Type 1 Standard	3 Kanal analog 3 Channel analogue	(tempostat®) (Cruise Control)	X39-737-100-001
Typ 1 / Type 1 Enhanced	3 Kanal analog 3 Channel analogue	(tempostat® + Geschwindigkeits- u. Drehzahlbegrenzung) (Cruise Control + Road speed limiter + Engine Speed Limiter)	X39-737-101-001
Typ 1 / Type 1 Premium	3 Kanal analog 3 Channel analogue	(tempostat® + Geschwindigkeits- u. Drehzahlbegrenzung + Drehzahlregelung) (Cruise Control + Road speed limiter + Engine Speed Limiter + Engine speed Controller)	X39-737-102-001
Typ 2 / Type 2 Standard	2 Kanal analog + 2 Schalter 2 Channel analogue + 2 switches	(tempostat®) (Cruise Control)	X39-737-200-001
Typ 2 / Type 2 Enhanced	2 Kanal analog + 2 Schalter 2 Channel analogue + 2 switches	(tempostat® + Geschwindigkeits- u. Drehzahlbegrenzung) (Cruise Control + Road speed limiter + Engine Speed Limiter)	X39-737-201-001
Typ 2 / Type 2 Premium	2 Kanal analog + 2 Schalter 2 Channel analogue + 2 switches	(tempostat® + Geschwindigkeits- u. Drehzahlbegrenzung + Drehzahlregelung) (Cruise Control + Road speed limiter + Engine Speed Limiter + Engine speed Controller)	X39-737-202-001

Regelelektronik

Systemkomponente für Pedal Interface II

Technische Daten:

Nennspannung:	12 V / 24 V
Betriebsspannung:	8 V bis 32 V
Stromverbrauch:	Kl.15 < 1 mA; Kl. 30 < 80 mA (< 10 mA standby)
Schutzart:	IP44 DIN 40050
Betriebstemperatur:	- 40°C bis 85°C (IEC 68-2-38)

Testspezifikationen:

Niedrig- und Hochtemperatur:	<ul style="list-style-type: none">- ISO 16750 Teil 4 Abschnitt 5.1.1.2 und 5.1.2.2- BS EN 60068-2: 1993 Test Ab- BS EN 60068-2: 1993 Test Bb
Zufallsbedingter Vibrationstest im Temperaturzyklus:	<ul style="list-style-type: none">- ISO 16750-3: 2003 (E) - Mechanische Last- IEC 68-2-64: 1993, zufällige Vibrationen: Methode 2- BS EN 60068-2-14: 2000 Test Nb, Umwelttest
Thermischer Schock:	<ul style="list-style-type: none">- ISO 16750 Teil 4 Abschnitt 5.3.3- BS EN 60068-2-14: 2000 Test Na
Temperatur und Feuchtigkeit:	<ul style="list-style-type: none">- ISO 16750 Teil 4 Abschnitt 5.6.2- BS EN 60068-2-38: 1999
Temperaturzyklus:	<ul style="list-style-type: none">- ISO 16750 Teil 4 Abschnitt 5.3.2- BS EN 60068-2-14: 2000 Test Nb
Zulassung nach EU-RL:	Geschwindigkeitsbegrenzer 92/24 (nur Version Enhanced und Premium) EMV 95/54
Gutachten:	Tempostat-Funktion geprüft durch eine technische Prüfstelle für den Kraftfahrzeugverkehr.

Electronic Controller

System component for Pedal Interface II

Technical Data:

Rated voltage:	12 V / 24 V
Operating voltage:	8 V to 32 V
Current consumption:	Term. 15 < 1 mA; Term. 30 < 80 mA (< 10 mA standby)
Protection:	IP44 DIN 40050
Operating temperature:	- 40°C to 85°C (IEC 68-2-38)

Test specifications:

Low- and high temperature:	<ul style="list-style-type: none">- ISO 16750 part 4 sections 5.1.1.2 and 5.1.2.2- BS EN 60068-2: 1993 Test Ab- BS EN 60068-2: 1993 Test Bb
Random vibration with temperature cycle:	<ul style="list-style-type: none">- ISO 16750-3: 2003 (E) - Mechanical loads- IEC 68-2-64: 1993, Random vibration: method 2- BS EN 60068-2-14: 2000 Test Nb, Environmental test
Thermal Shock:	<ul style="list-style-type: none">- ISO 16750 part 4 section 5.3.3- BS EN 60068-2-14: 2000 Test Na
Temperature and humidity:	<ul style="list-style-type: none">- ISO 16750 part 4 section 5.6.2- BS EN 60068-2-38: 1999
Temperature cycle:	<ul style="list-style-type: none">- ISO 16750 part 4 section 5.3.2- BS EN 60068-2-14: 2000 Test Nb
Registration according to EC directive:	Road speed limiter 92/24 (only Version Enhanced and Premium) EMC 95/54
Expertise:	Cruise control function tested by a government approved body

Einbausatz

Systemkomponente für
Pedal Interface II

Installation Kit

System component for
Pedal Interface II

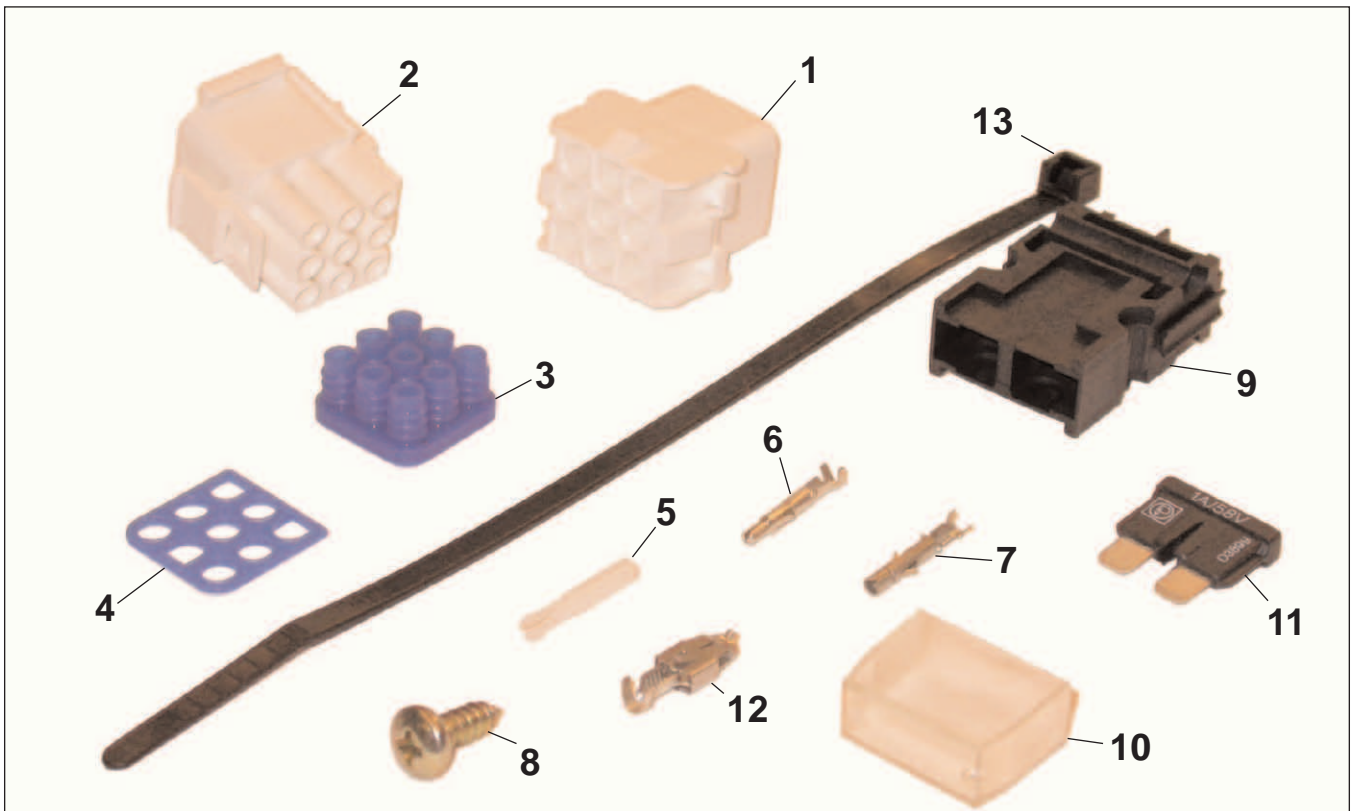

Der Einbausatz besteht aus:

The installation kit is consisting of:

Pos.	Benennung / Designation			Mindest Bestellmenge / minimum order quantity
1	Kupplungsgehäuse / Coupling housing	2x	X11-737-002-002	10
2	Steckergehäuse / Connector housing	2x	X11-737-002-001	10
3	Aderdichtung / Conductor seal	4x	X11-737-002-004	20
4	Schnittstellendichtung / Interface seal	2x	X11-737-002-003	10
5	Kodierstift / Coding pin	10x	X11-737-002-005	50
6	Stiftkontakt / Pin contact	9x	X11-737-002-006	100
7	Buchsenkontakt / Bush contact	9x	X11-737-002-007	100
8	Kreuzschlitzschraube / Cross-hand screw 4,8 x 13	2x		
9	Sicherungsgehäuse / Fuse housing	2x	X11-737-002-009	10
10	Kappe Sicherungsgehäuse / Cap fuse housing	2x	X11-737-002-012	10
11	Sicherung 1A / Fuse 1A	2x	X11-737-002-010	10
12	Kontaktbuchse für Sicherungsgehäuse / Contact socket for fuse housing	4x	X11-737-002-011	20
13	Kabelbinder / Cable tie	10x		

Bestell-Nr. / Order No.: X39-737-300-003

Kabelbaum

Systemkomponente für
Pedal Interface II

Wiring Harness

System component for
Pedal Interface II

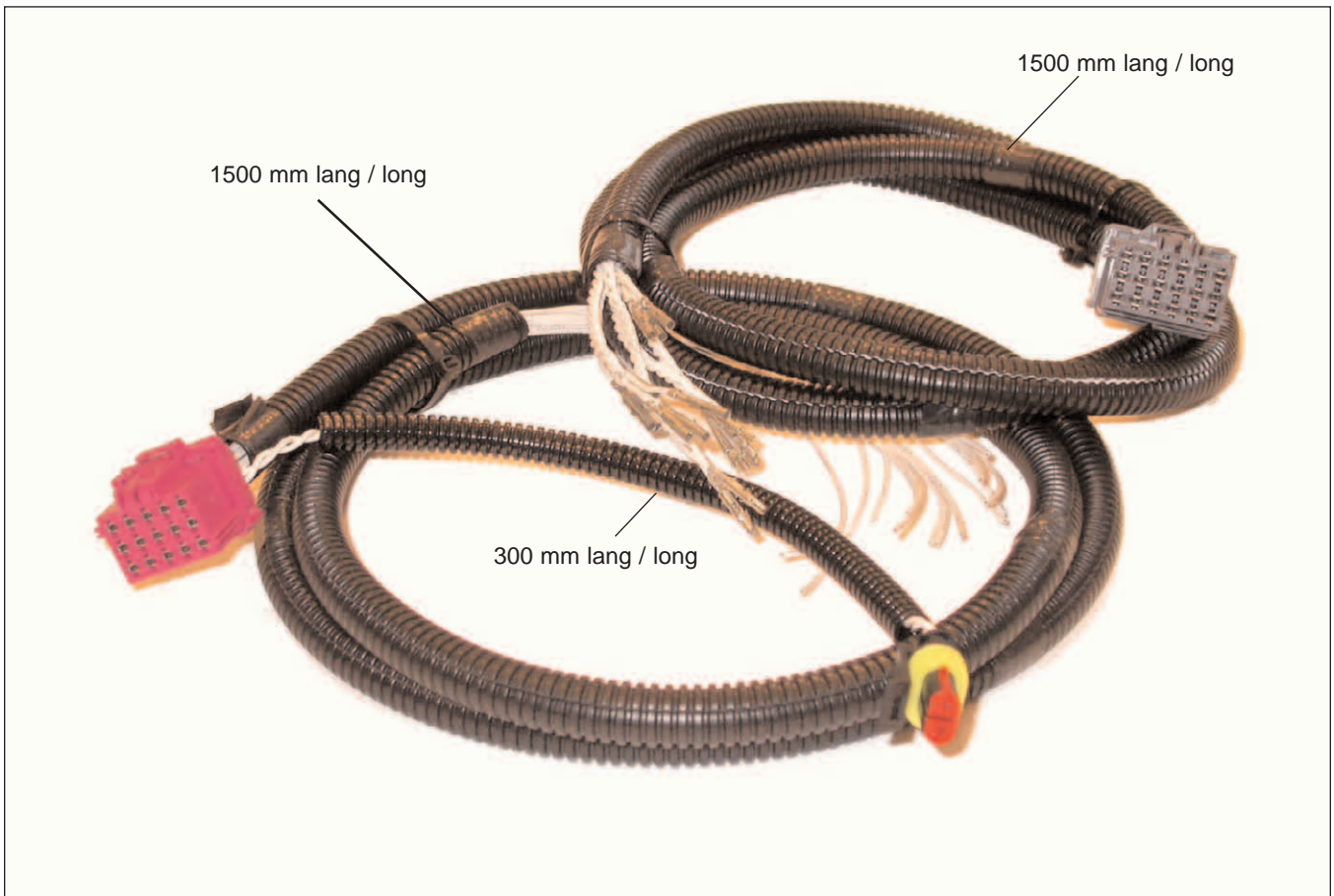

Technische Daten:

Max. Belastung:	5A
Leitung:	B 0,5 nach DIN 72551
Betriebstemperatur:	- 40°C bis + 105 °C
Schutzart (Trennstelle Pedal):	IP65 DIN 40050

Technical Data:

Max. strain:	5A
Wire:	B 0.5 acc. DIN 72551
Operating temperature:	- 40°C to + 105 °C
Protection (separating point pedal):	IP65 DIN 40050

Bestell-Nr. / Order No: X39-737-300-008

Bedienteil für Drehzahlregelung

Systemkomponente für
Pedal Interface II

Hand Set Rpm Control (PTO)

System component for
Pedal Interface II

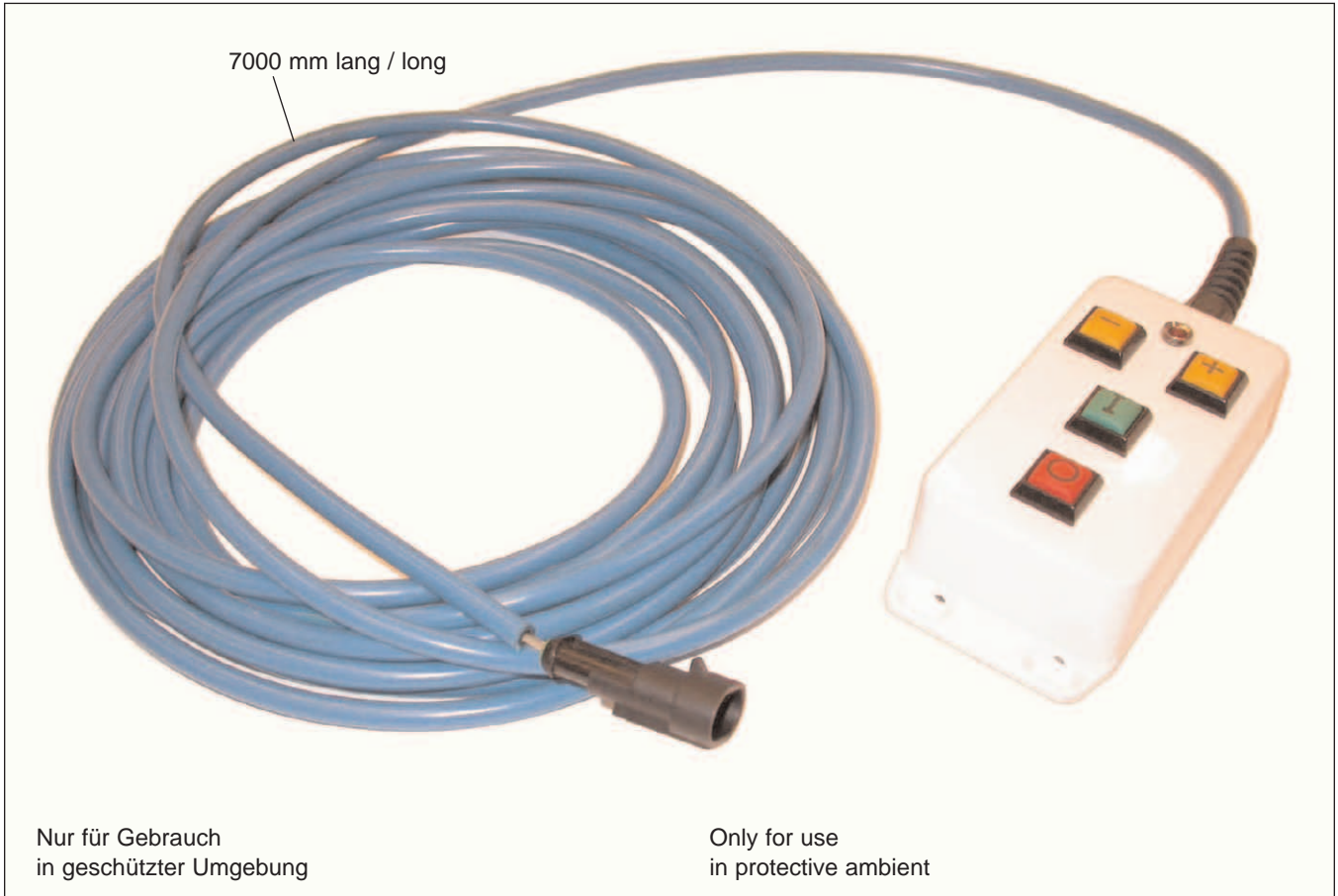

Technische Daten:

Zweidrahtschnittstelle, seriell	
Betriebstemperatur:	- 40°C bis + 85°C

Technical Data:

Double-wire interface, serial	
Operating temperature:	- 40°C to + 85°C

Bestell-Nr . / Order No: X39-737-003-003

Pedal Interface Dongle Level 1 (Master Dongle)

Systemkomponente für Pedal Interface II

Beschreibung:

Master Dongle: Erlaubt Zugriff auf alle Funktionen inkl. Erstellung und speichern von neuen Master files.

System component for Pedal Interface II

Description:

Master Dongle: Permits access to all functions. Can create and save master files and activated all functions.

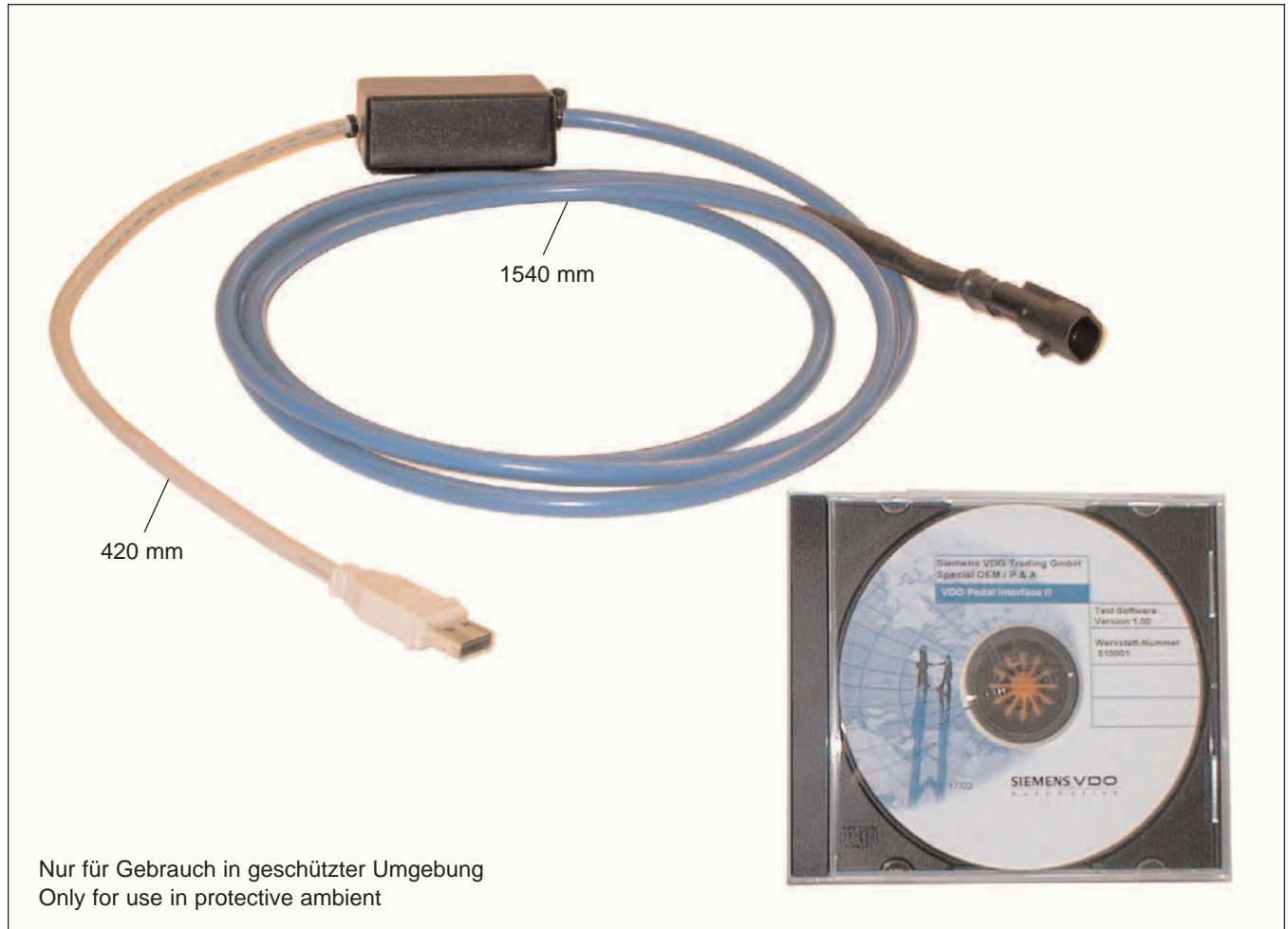

Technische Daten:

Anschluss an:	PC USB
Betriebstemperatur:	0 °C bis + 50 °C

Technical Data:

Connected on:	PC USB
Operating temperature:	0 °C to + 50 °C

Bestell-Nr. / Order No: X12-737-100-001

Pedal Interface Dongle Level 2

(Dongle für ermächtigte Werkstätten nach EU RL 92/6)

Dongle for authorised workshops according to EC directive 92/6)

Systemkomponente für Pedal Interface II

System component for Pedal Interface II

Beschreibung:

Workshop Dongle: Erlaubt Zugriff auf alle Funktionen inkl. maximaler Geschwindigkeitsbegrenzung.

Description:

Master Dongle: Permits access to all functions including maximum Road Speed Limit.

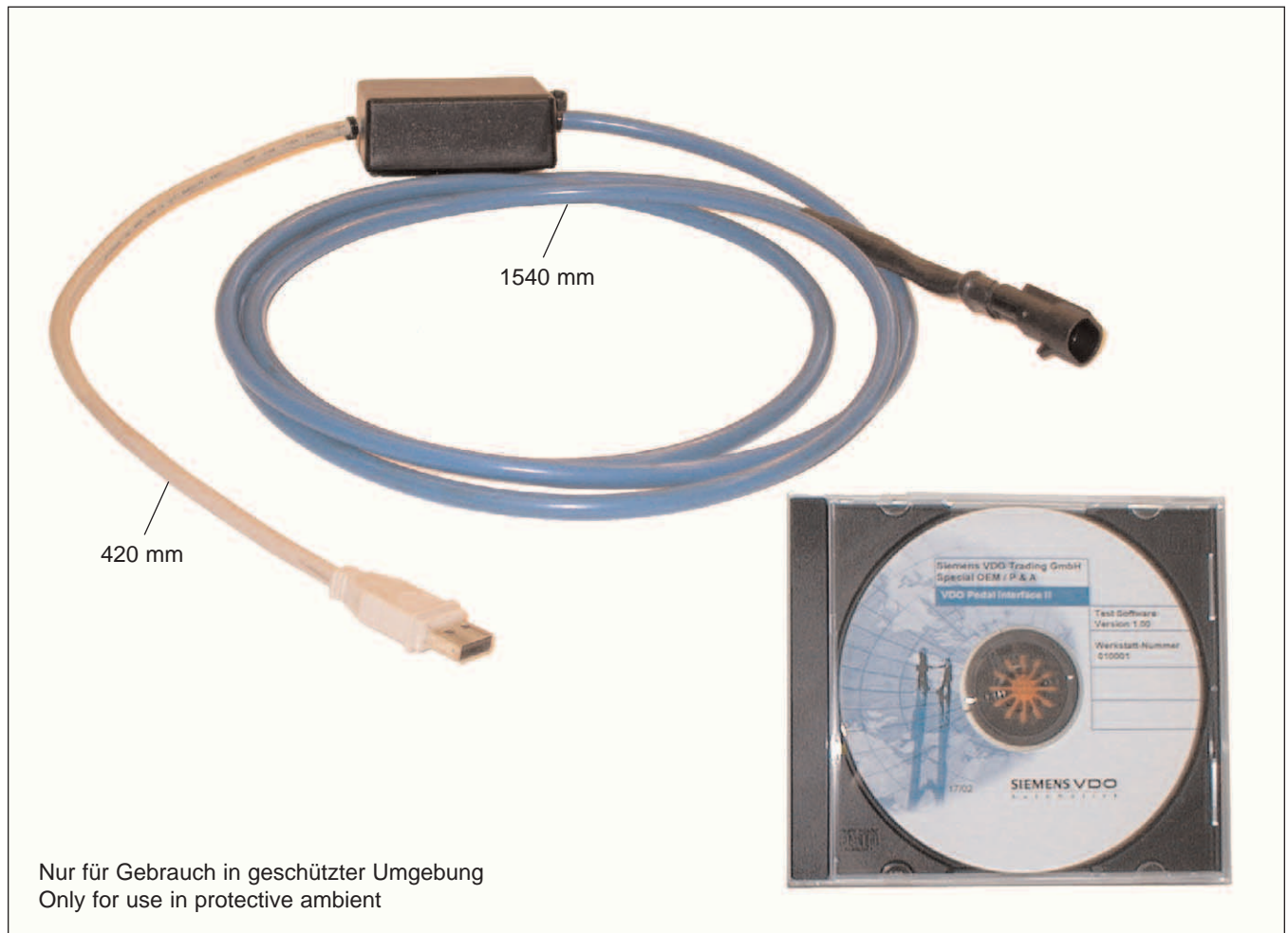

Technische Daten:

Anschluss an:	PC USB
Betriebstemperatur:	0 °C bis + 50 °C

Technical Data:

Connected on:	PC USB
Operating temperature:	0 °C to + 50 °C

Bestell-Nr. / Order No: X12-737-100-002

Pedal Interface Dongle Level 3

(Dongle für ermächtigte Werkstätten nach EU RL 92/6)

Dongle for authorised workshops according to EC directive 92/6)

Systemkomponente für Pedal Interface II

System component for Pedal Interface II

Beschreibung:

Dieser Dongle erlaubt: Zugriff auf tempostat®- Funktion und Drehzahlregelung (Feste Drehzahl-, variable Drehzahlregelung und Gaspedal Stellungsbegrenzung).

Description:

This Dongle permits: Access to the Cruise Control and RPM Control (Fixed rpm, variable rpm and pedal position limiter).

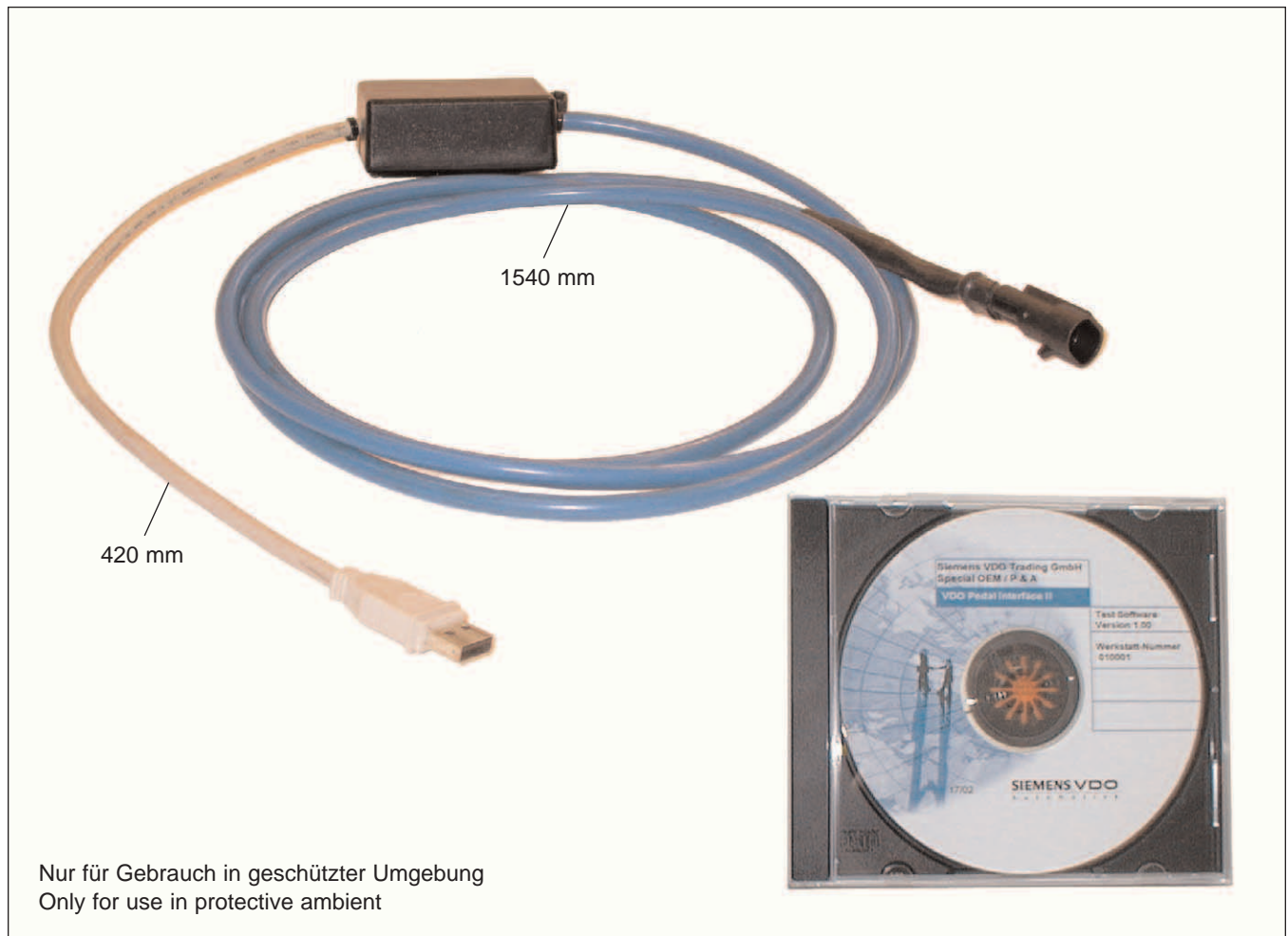

Technische Daten:

Anschluss an:	PC USB
Betriebstemperatur:	0 °C bis + 50 °C

Technical Data:

Connected on:	PC USB
Operating temperature:	0 °C to + 50 °C

Bestell-Nr. / Order No: X12-737-100-003

Kupplungsschalter

Systemkomponente für
Pedal Interface II

Clutch Switch

System component for
Pedal Interface II

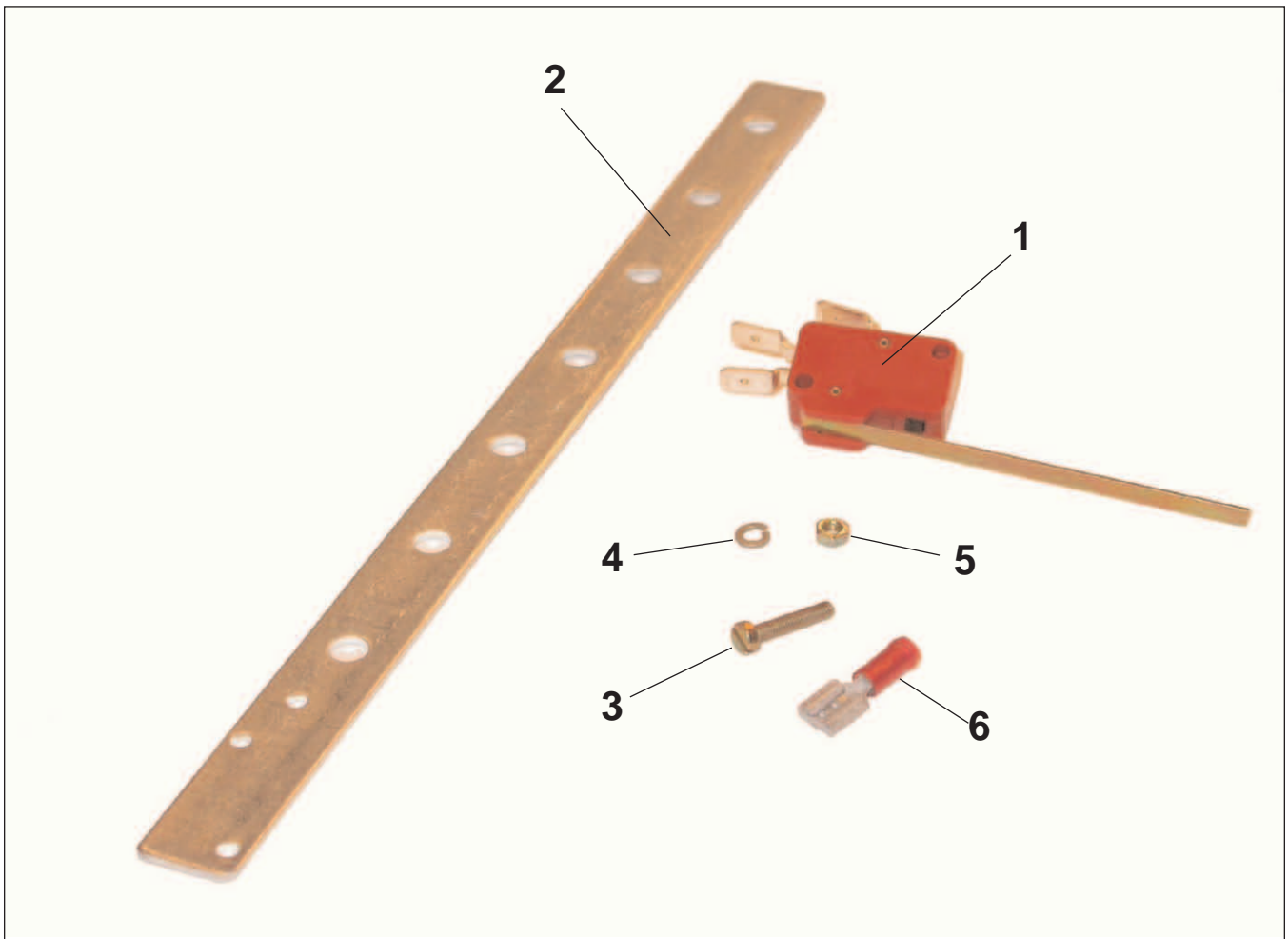

Der Kupplungsschalter besteht aus:

The clutch switch is consisting of:

Pos.	Benennung / Designation			Mindest Bestellmenge / minimum order quantity
1	Kupplungsschalter / Clutch switch	1x	X39-397-106-135	
2	Halter / Mounting bracket	1x	X39-397-106-125	10
3	Zylinderkopfschraube / cheese hd. screw (M3x16 ISO 1207-St)	2x		
4	Federring / Lock washer (3 DIN 127-St)	2x		
5	Sechskantmutter / Hex nut (M3 ISO 4032-St)	2x		
6	Flachsteckhülse / Female connector (6,3x0,8)	2x	4-711-025-011	100

Bestell-Nr. / Order No.: X39-397-106-152

Kupplungsschalter, berührungslos

Systemkomponente für
Pedal Interface II

Clutch Switch, contact less

System component for
Pedal Interface II

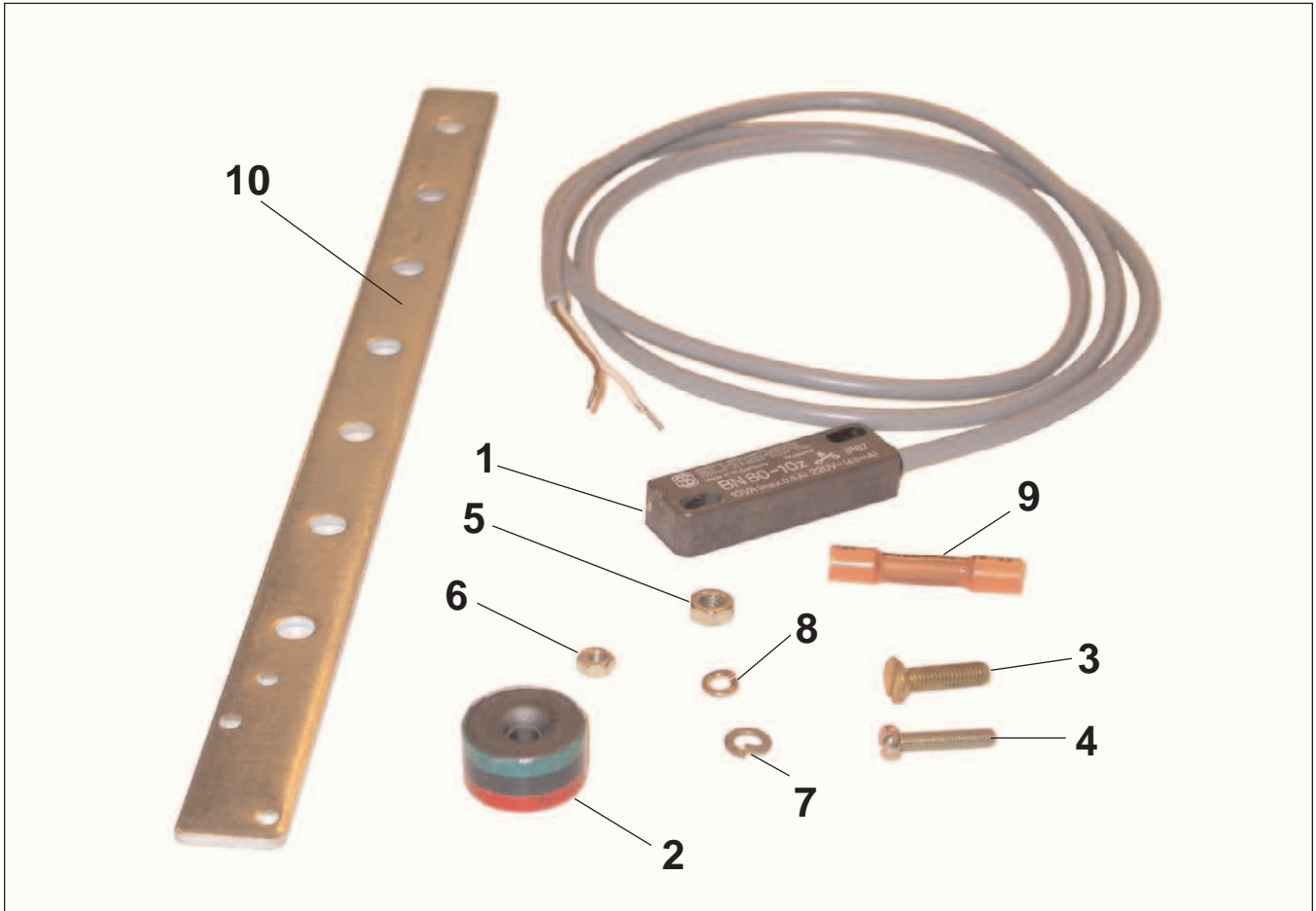

Der Kupplungsschalter besteht aus:

The clutch switch is consisting of:

Pos.	Benennung / Designation			Mindest Bestellmenge / minimum order quantity
1	Kupplungsschalter / Clutch switch	1x	X39-397-106-127	
2	Magnet / Magnet	1x	X39-397-106-128	
3	Senkschraube / Countersunk screw M4 x 16	1x		
4	Zyl. Schraube / Cheese-head screw M3 x 16	2x		
5	Mutter / Nut M4	1x		
6	Mutter / Nut M3	2x		
7	Federring / Spring ring A4	1x		
8	Federring / Spring ring A3	2x		
9	Quetschverbinder / Crimp connector (schrumpfbar / shrinkable)	2x	X39-397-106-143	100
10	Halter Kupplungsschalter / Bracket clutch switch	1x	X39-397-106-125	10

Bestell-Nr. / Order No.: X39-737-300-009

Einbausatz Kupplungsschalter, rund (M10x1)

Systemkomponente für
Pedal Interface II

Installation Kit Clutch Switch, round (M10x1)

System component for
Pedal Interface II

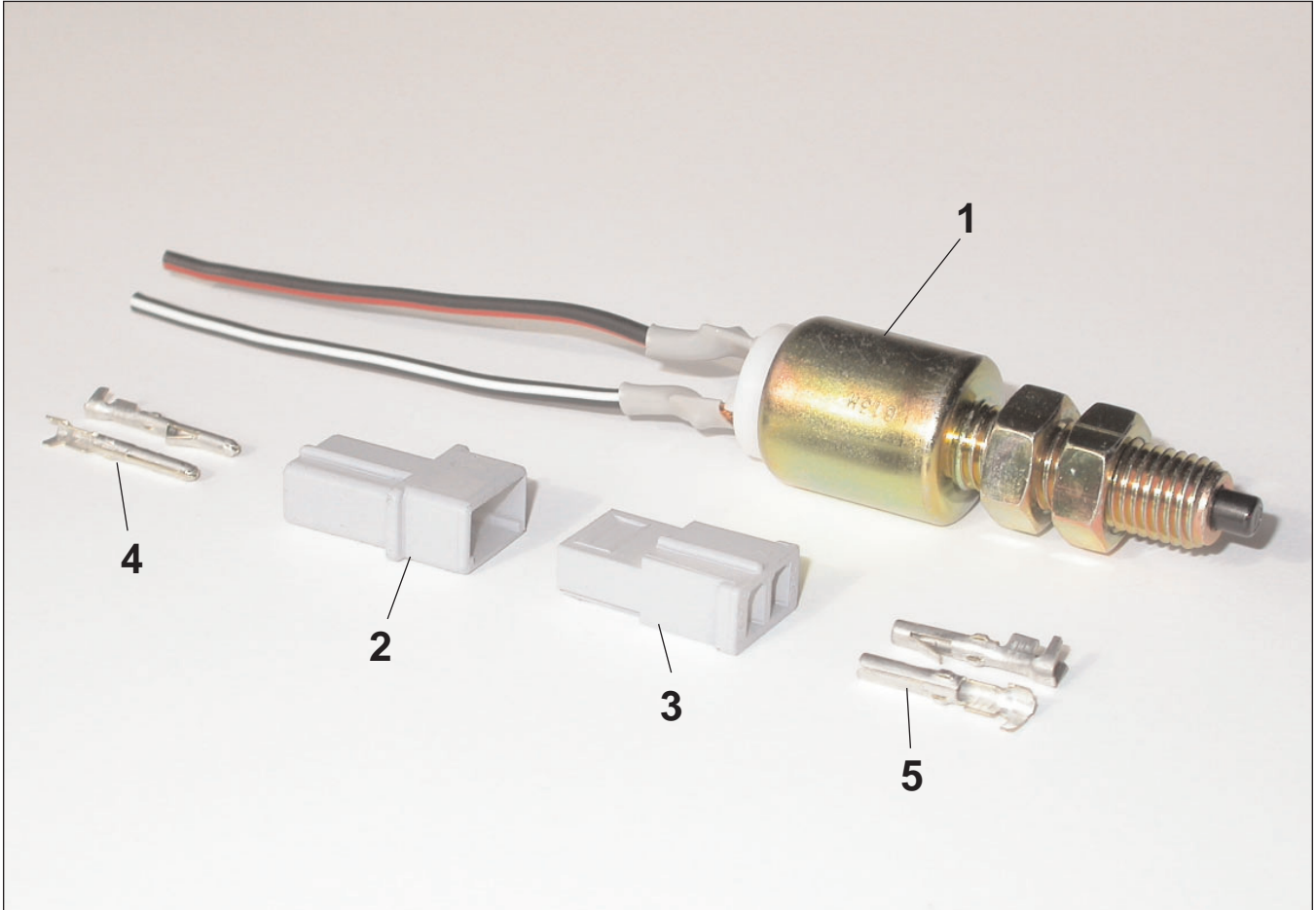

Der Einbausatz Kupplungsschalter besteht aus:

The installation kit clutch switch is consisting of:

Pos.	Benennung / Designation			Mindest Bestellmenge / minimum order quantity
1	Kupplungsschalter / Clutch switch	1x		
2	Steckergehäuse (Steckerstift) / Connector housing (Connector pin)	1x	A2C59511543	10
3	Steckergehäuse (Steckerbuchse) / Connector housing (Female connector)	1x	A2C59511544	10
4	Steckerstift / Connector pin (0,2-0,8mm ²)	2x	A2C59511545	20
5	Steckerbuchse / Female connector (0,2-0,8mm ²)	2x	A2C59511546	20

Bestell-Nr. / Order No.: A2C59511557

Einbausatz LED 12 VDC Grün

Systemkomponente für
Pedal Interface II

Installation Kit LED 12 VDC Green

System component for
Pedal Interface II

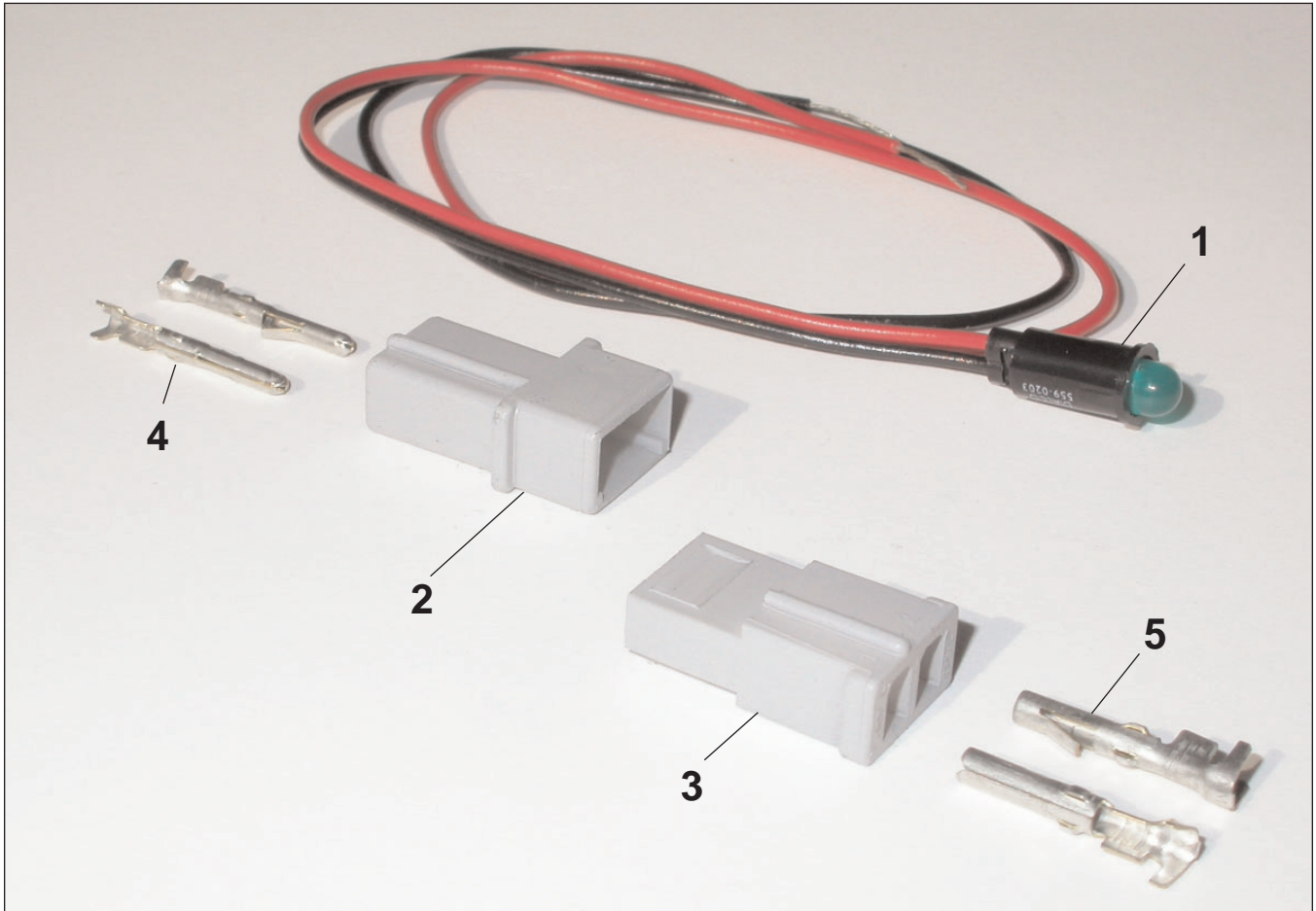

Der Einbausatz LED besteht aus:

The installation kit LED is consisting of:

Pos.	Benennung / Designation			Mindest Bestellmenge / minimum order quantity
1	LED 12V grün / green	1x		
2	Steckergehäuse (Steckerstift) / Connector housing (Connector pin)	1x	A2C59511543	10
4	Steckerstift / Connector pin (0,2-0,8mm ²)	2x	A2C59511545	20
Optional (nicht im Einbausatz enthalten) / Option (not contained in the installation kit):				
3	Steckergehäuse (Steckerbuchse) / Connector housing (Female connector)	1x	A2C59511544	10
5	Steckerbuchse / Female connector (0,2-0,8mm ²)	2x	A2C59511546	20

Bestell-Nr. / Order No.: A2C59511548

Standard Bedienhebel

Systemkomponente für
tempostat® 12V, AGB Komfort, E-Gas® II
E-Gas® compact, Pedal Interface II

Standard control stalk

System component for
tempostat® 12V, RSL Comfort, E-Gas® II
E-Gas® compact, Pedal Interface II

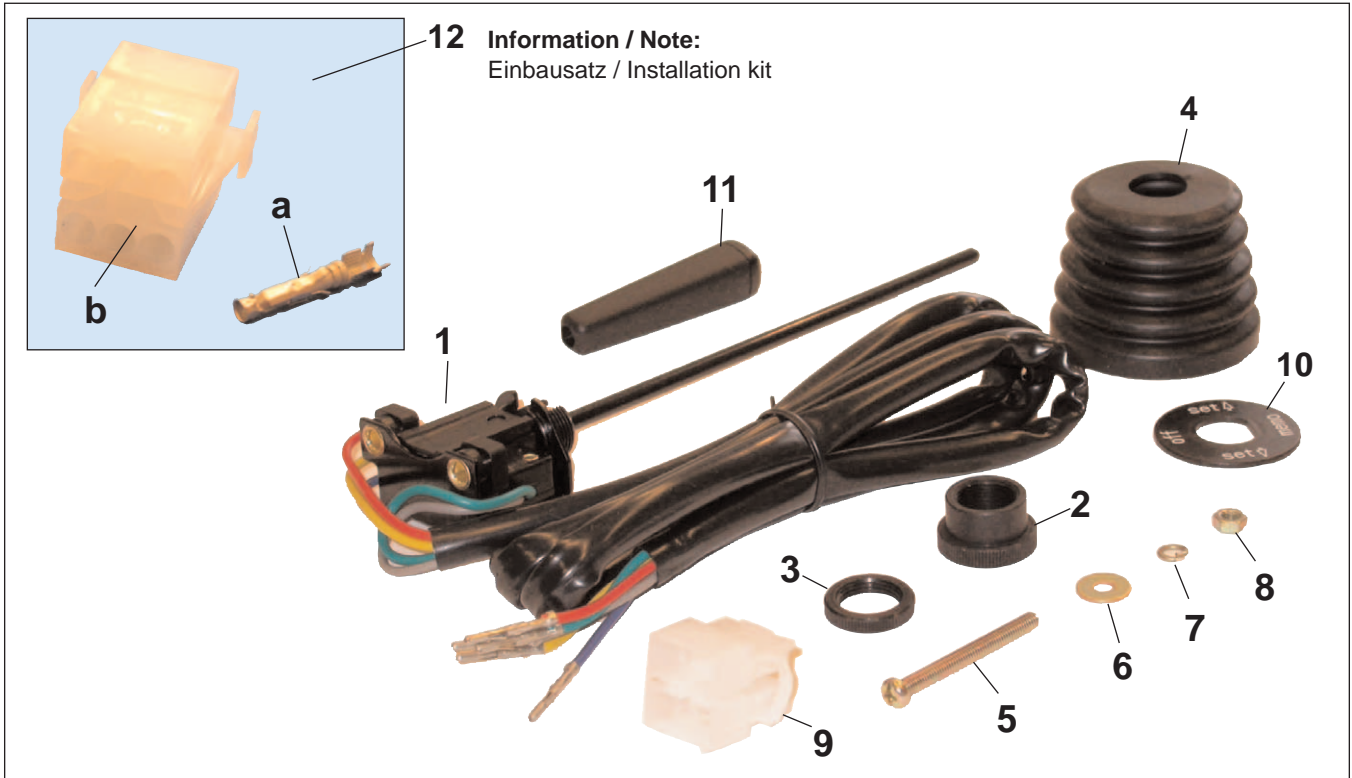

Der Einbausatz besteht aus:

The installation kit is consisting of:

Pos.	Benennung / Designation		
1	Bedienhebel / Control stalk	1x	
2	Gewindehülse / Threaded sleeve (M14 x 1)	1x	
3	Rändelmutter / Knurled nut (M14x1)	1x	
4	Faltenbalg / Bellows	1x	
5	Zylinderkopfschraube / Cheese hd. screw (M4x40 DIN 84)	2x	
6	Scheibe / Washer (4,2 DIN 9021)	2x	
7	Federring / Lock washer (4 DIN 127)	2x	
8	Sechskantmutter / Hex nut (M4 DIN 934)	2x	
9	Steckerstiftgehäuse, 6polig / Pin housing, 6-pole	1x	
10	Blende / Cover	1x	
11	Griff / Grip	1x	
12	Information / Note: Einbausatz Standard Bedienhebel / Installation kit standard stalk (Gehört nicht zum Lieferumfang, falls notwendig bitte separat bestellen / This is not part of the supply, if necessary please order separatly).		X39-737-300-010
a	Buchsenkontakt / Bush contact	6x	X11-708-002-023
b	Kupplungsgehäuse / Coupling housing	1x	X11-708-002-027

TU00-0785-5104620 | 0806 | Technische Änderungen vorbehalten | Technical details subject to change

Standard Bedienhebel

Systemkomponente für
temostat® 12V, AGB Komfort, E-Gas® II
E-Gas® compact, Pedal Interface II

Standard control stalk

System component for
temostat® 12V, RSL Comfort, E-Gas® II
E-Gas® compact, Pedal Interface II

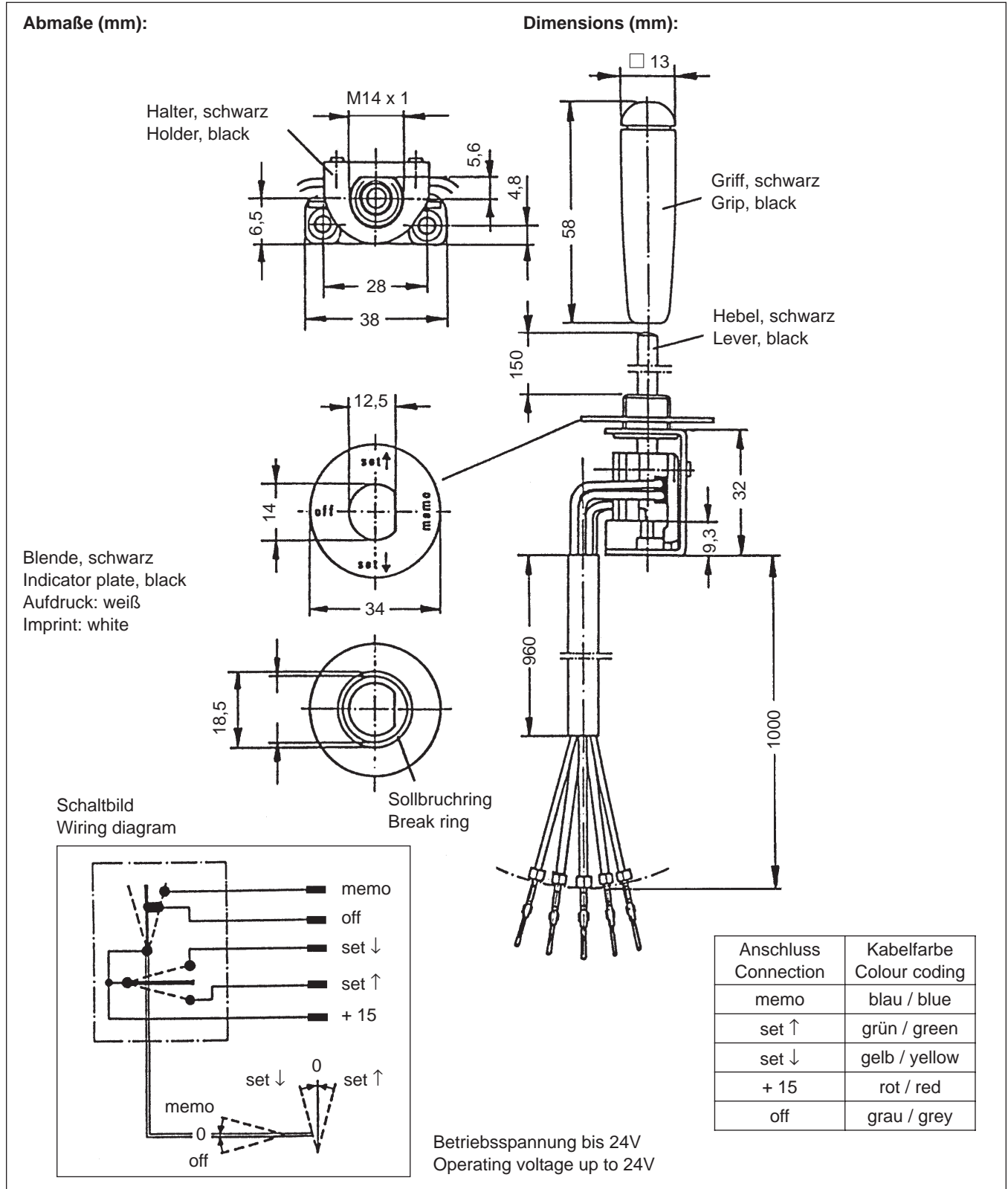

Bestell-Nr. / Order No.: X39-397-106-149

LED Bedienhebel rechts

Systemkomponente für
Pedal Interface II
(nur für 12V Anwendung)

LED control stalk right hand

System component for
Pedal Interface II
(only for 12V application)

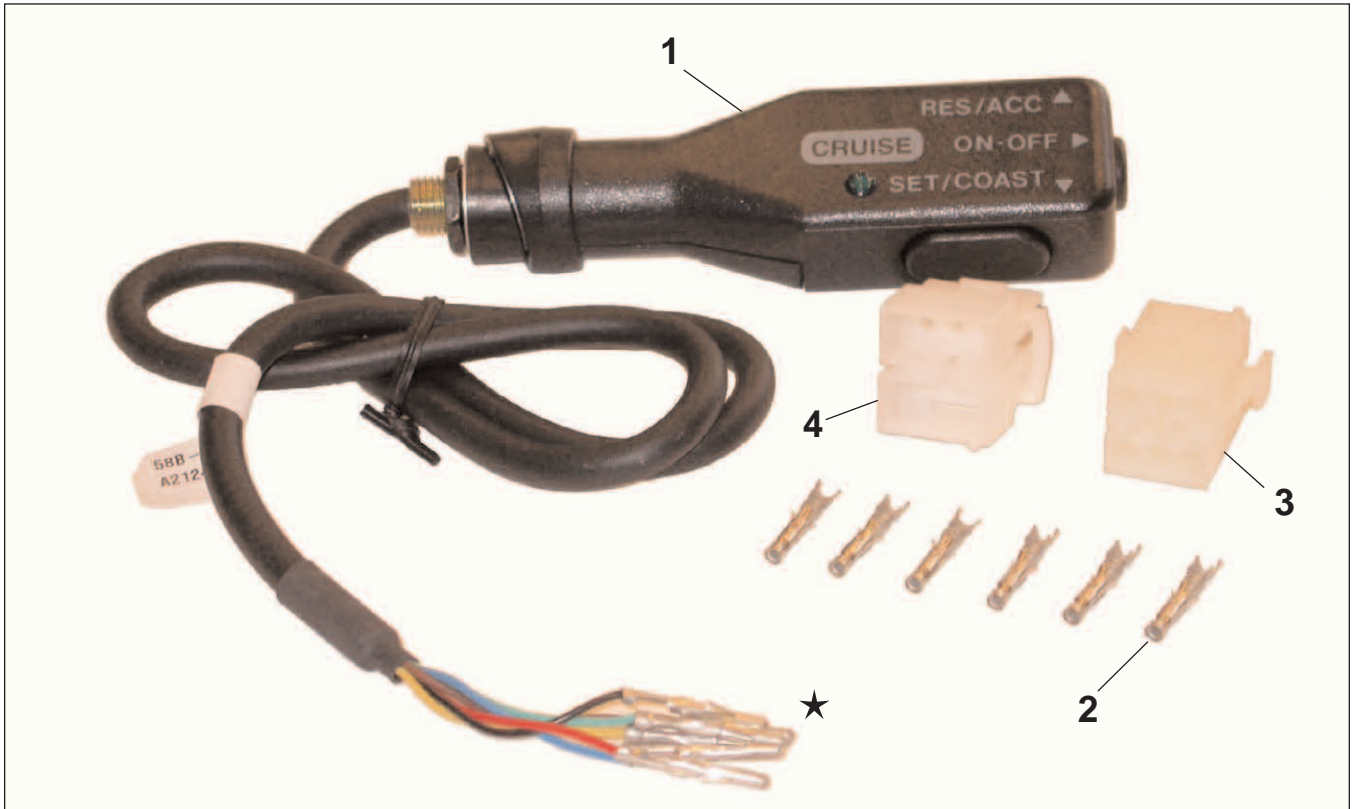

Der Einbausatz besteht aus:

The installation kit is consisting of:

Pos.	Benennung / Designation		
1	LED Bedienhebel / LED Control stalk	1x	
2	Buchsenkontakt / Bush contact	6x	X11-708-002-023
3	Kupplungsgehäuse / Coupling housing	1x	X11-708-002-027
4	Steckergehäuse / Connector housing	1x	X39-397-106-069
★	Stiftkontakt / Pin contact	6x	X11-708-002-022

Bestell-Nr. / Order No.: X39-737-300-004

LED Bedienhebel links

Systemkomponente für
Pedal Interface II
(nur für 12V Anwendung)

LED control stalk left hand

System component for
Pedal Interface II
(only for 12V application)

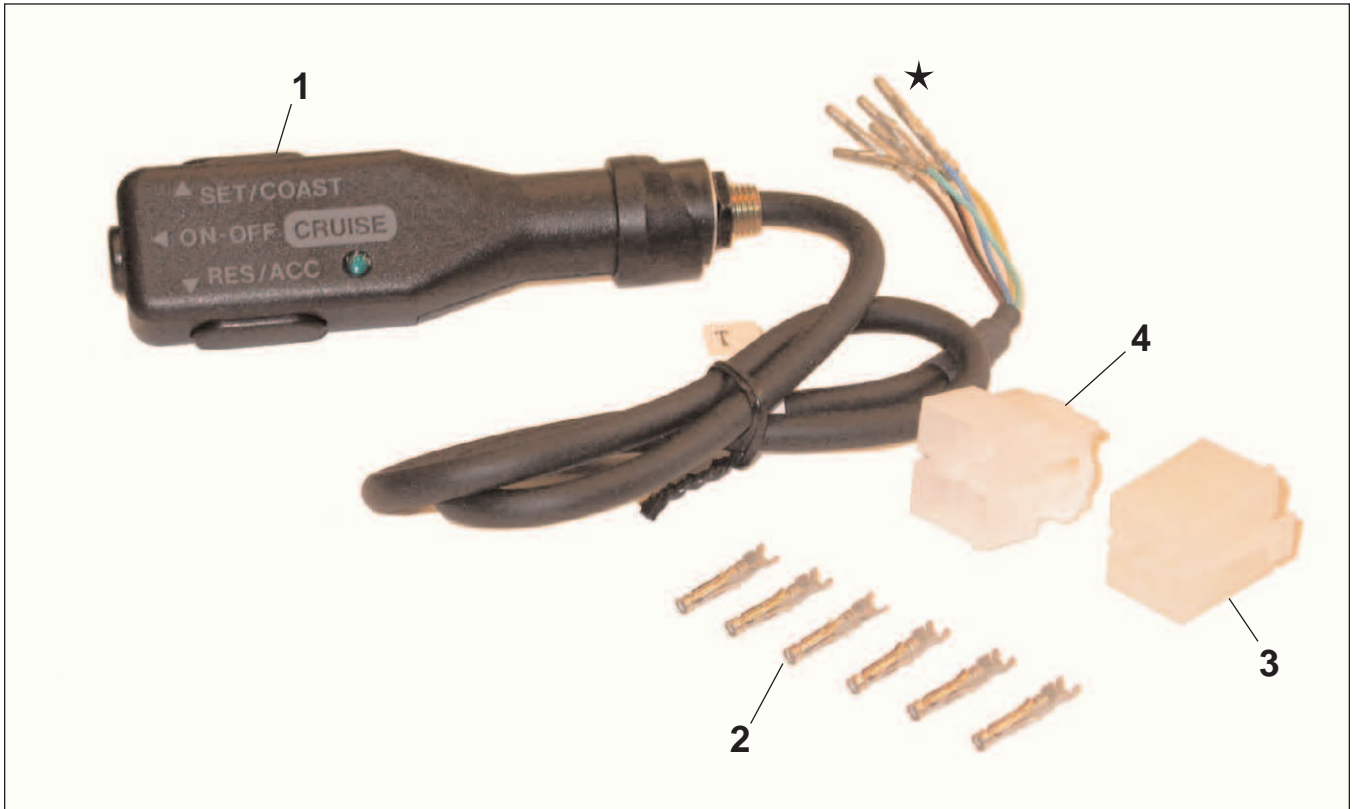

Der Einbausatz besteht aus:

The installation kit is consisting of:

Pos.	Benennung / Designation		
1	LED Bedienhebel / LED control stalk	1x	
2	Buchsenkontakt / Bush contact	6x	X11-708-002-023
3	Kupplungsgehäuse / Coupling housing	1x	X11-708-002-027
4	Steckergehäuse / Connector housing	1x	X39-397-106-069
★	Stiftkontakt / Pin contact	6x	X11-708-002-022

Bestell-Nr. / Order No.: X39-737-300-005

Bedienhebel rechts, flexibel

Systemkomponente für
Pedal Interface II

Flexible control stalk right hand

System component for
Pedal Interface II

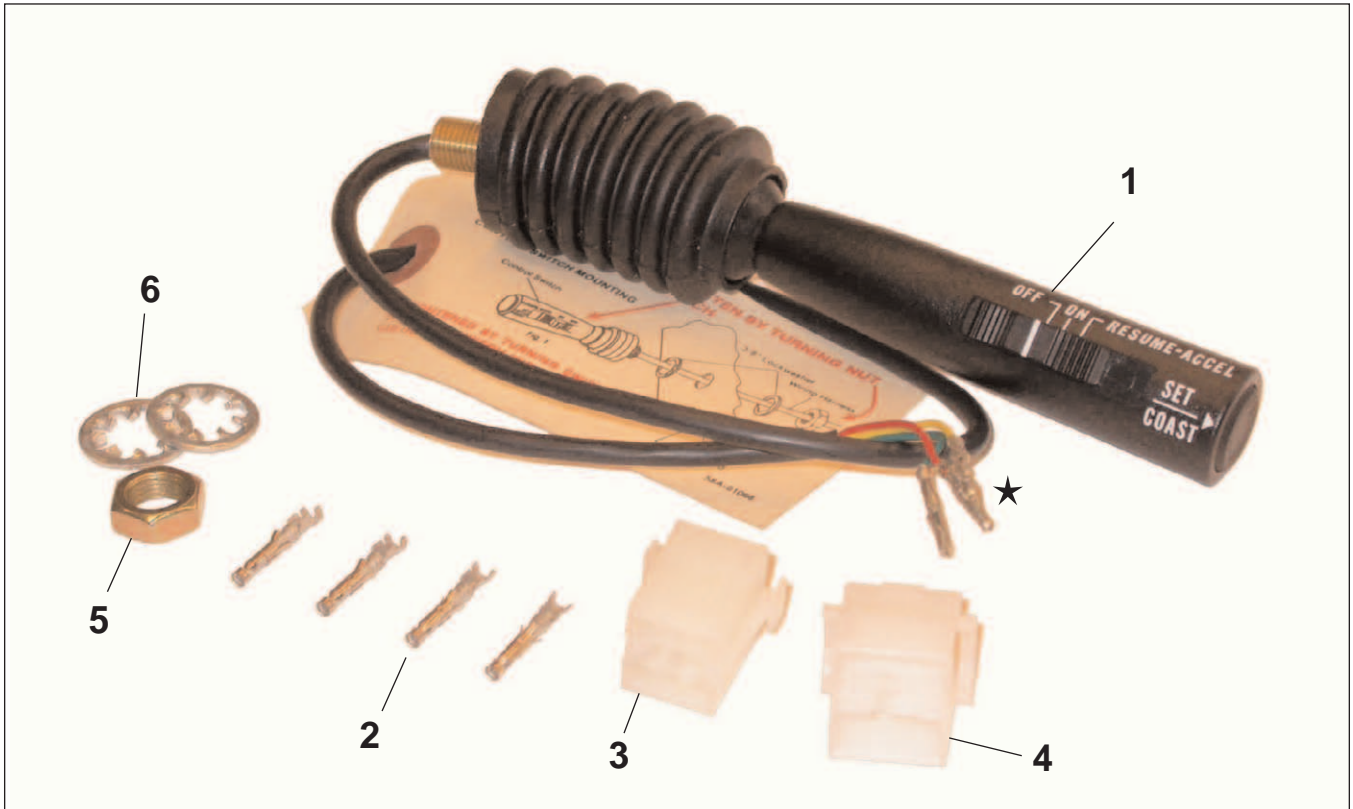

Der Einbausatz besteht aus:

The installation kit is consisting of:

Pos.	Benennung / Designation		
1	Flexibler Bedienhebel / Flexible control stalk	1x	
2	Buchsenkontakt / Bush contact	4x	X11-708-002-023
3	Kupplungsgehäuse / Coupling housing	1x	X11-708-002-027
4	Steckergehäuse / Connector housing	1x	X39-397-106-069
5	Flache Sechskantmutter M10 / Flat hexagon nut M10	1x	
6	Fächerscheibe 10,5 / Serrated washer 10.5	2x	
★	Stiftkontakt / Pin contact	4x	X11-708-002-022

Bestell-Nr. / Order No.: X39-737-300-006

Bedienhebel links, flexibel

Systemkomponente für
Pedal Interface II

Flexible control stalk left hand

System component for
Pedal Interface II



Der Einbausatz besteht aus:

The installation kit is consisting of:

Pos.	Benennung / Designation		
1	Flexibler Bedienhebel / Flexible control stalk	1x	
2	Buchsenkontakt / Bush contact	4x	X11-708-002-023
3	Kupplungsgehäuse / Coupling housing	1x	X11-708-002-027
4	Steckergehäuse / Connector housing	1x	X39-397-106-069
5	Flache Sechskantmutter M10 / Flat hexagon nut M10	1x	
6	Fächerscheibe 10,5 / Serrated washer 10.5	2x	
★	Stiftkontakt / Pin contact	4x	X11-708-002-022

Bestell-Nr. / Order No.: X39-737-300-007

Typenspezifische Anlage

Mitsubishi Colt 2004/2005
Pedal Interface II

Type specific System

Mitsubishi Colt 2004/2005
Pedal Interface II

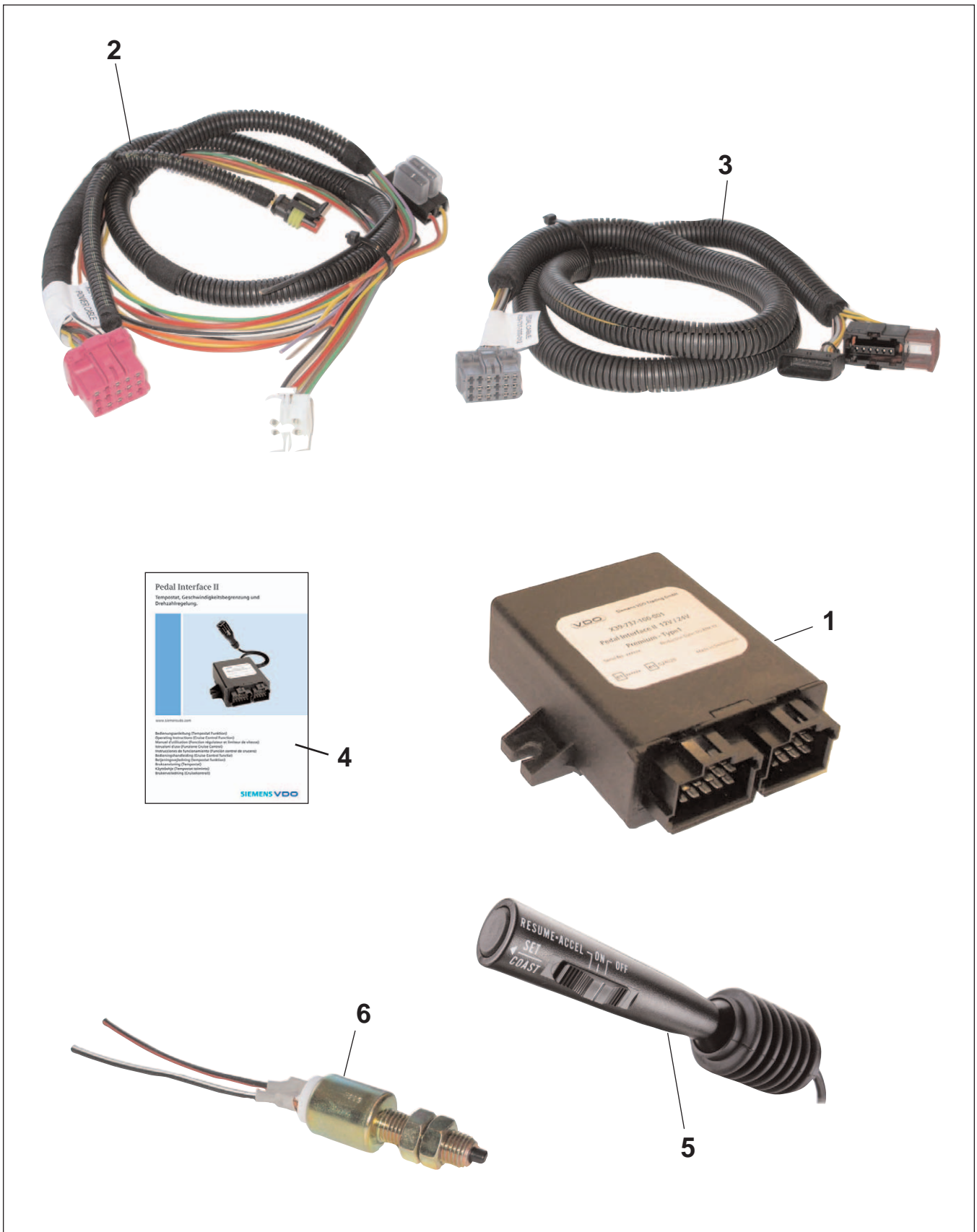

TU00-0050-6504620 | 0507 | Technische Änderungen vorbehalten | Technical details subject to change

Typenspezifische Anlagen Type specific System

Pedal Interface II

Pedal Interface II

Die Anlage besteht aus:

The system is consisting of:

Pos.	Mitsubishi Colt, Modell 2004/05, DID & CZT, 5 Gear Manual Transmission 1.5 MPI Turbo: 1.5L Petrol 110 kW (CZT) MT 1.5 DI-D Turbo: 1.5L Diesel 50 kW or 70kW MT	X10-737-100-002
1	Elektronischer Regler / Electronic Control Unit Für Ersatzbedarf muß der Regler durch autorisierte Stelle programmiert werden For replacement the ECU must be programmed by an authorised workshop File name: Colt MTDID&CZT.P2U	X39-737-100-001
2	Kabelbaum Spannungsversorgung / Power Supply Harness	X39-737-300-011
3	Kabelbaum Pedal / Pedal Harness	X39-737-300-012
4	Bedienungsanleitung / Operating instruction	TU00-0050-5110591
5	Bedienhebel / Control Stalk	X39-737-300-007

Pos.	Mitsubishi Colt, Modell 2004/05, 6 Gear Allshift Transmission 1.3 MPI: 1.3L Petrol 70kW 1.5 MPI: 1.5L Petrol 80 kW 1.5 DI-D Turbo: 1.5L Turbo-Diesel 70 kW	X10-737-100-003
1	Elektronischer Regler / Electronic Control Unit Für Ersatzbedarf muß der Regler durch autorisierte Stelle programmiert werden For replacement the ECU must be programmed by an authorised workshop File name:Colt AS.P2U	X39-737-100-001
2	Kabelbaum Spannungsversorgung / Power Supply Harness	X39-737-300-011
3	Kabelbaum Pedal / Pedal Harness	X39-737-300-012
4	Bedienungsanleitung / Operating instruction	TU00-0050-5110591
5	Bedienhebel / Control Stalk	X39-737-300-007

Pos.	Mitsubishi Colt, Modell 2004/05, 5 Gear Manual Transmission 1.1 MPI: 1.1L Petrol 55kW 1.3 MPI: 1.3L Petrol 70kW 1.5 MPI: 1.5L Petrol 80kW	X10-737-100-004
1	Elektronischer Regler / Electronic Control Unit Für Ersatzbedarf muß der Regler durch autorisierte Stelle programmiert werden For replacement the ECU must be programmed by an authorised workshop File name: Colt MT.P2U	X39-737-100-001
2	Kabelbaum Spannungsversorgung / Power Supply Harness	X39-737-300-011
3	Kabelbaum Pedal / Pedal Harness	X39-737-300-012
4	Bedienungsanleitung / Operating instruction	TU00-0050-5110591
5	Bedienhebel / Control Stalk	X39-737-300-007
6	Kupplungsschalter / Clutch Switch	A2C59511557

Typenspezifische Anlage

Ssang Yong Actyon, Kyron, Rodius 2006
Pedal Interface II

Type specific System

Ssang Yong Actyon, Kyron, Rodius 2006
Pedal Interface II



TU00-0050-6504620 | 0507 | Technische Änderungen vorbehalten | Technical details subject to change

Typenspezifische Anlagen Type specific System

Pedal Interface II

Pedal Interface II

Die Anlage besteht aus:

The system is consisting of:

Pos.	Ssang Yong Kyron, Modell 2006, 200 xdi / 2,0L Diesel / 143 hp (105 kW), Manual Transmission	X10-737-100-005
1	Elektronischer Regler / Electronic Control Unit Für Ersatzbedarf muß der Regler durch autorisierte Stelle programmiert werden For replacement the ECU must be programmed by an authorised workshop File name: KyronFinal.P2U	X39-737-100-001
2	Kabelbaum Spannungsversorgung / Power Supply Harness	X39-737-300-015
3a	Kabelbaum Pedal / Pedal Harness	X39-737-300-017
4	Bedienungsanleitung / Operating instruction	TU00-0050-5110591
5	Bedienhebel / Control Stalk	X39-737-300-005

Pos.	Ssang Yong Actyon, Modell 2006, 200 xdi / 2,0L Diesel / 143 hp (105 kW), Manual Transmission	X10-737-100-007
1	Elektronischer Regler / Electronic Control Unit Für Ersatzbedarf muß der Regler durch autorisierte Stelle programmiert werden For replacement the ECU must be programmed by an authorised workshop File name: ActyonFinal.P2U	X39-737-100-001
2	Kabelbaum Spannungsversorgung / Power Supply Harness	X39-737-300-015
3a	Kabelbaum Pedal / Pedal Harness	X39-737-300-017
4	Bedienungsanleitung / Operating instruction	TU00-0050-5110591
5	Bedienhebel / Control Stalk	X39-737-300-005

Pos.	Ssang Yong Rodius, Modell 2005, 270 xdi / 2,7L Diesel / 164 hp (121 kW), Manual Transmission	X10-737-100-008
1	Elektronischer Regler / Electronic Control Unit Für Ersatzbedarf muß der Regler durch autorisierte Stelle programmiert werden For replacement the ECU must be programmed by an authorised workshop File name: ActyonFinal.P2U	X39-737-100-001
2	Kabelbaum Spannungsversorgung / Power Supply Harness	X39-737-300-015
3b	Kabelbaum Pedal / Pedal Harness	X39-737-300-016
4	Bedienungsanleitung / Operating instruction	TU00-0050-5110591
5	Bedienhebel / Control Stalk	X39-737-300-005

Typenspezifische Anlage

Toyota Yaris, RAV 4 2006, Auris 2007
Pedal Interface II

Type specific System

Toyota Yaris, RAV 4 2006, Auris 2007
Pedal Interface II



TU00-0050-6504620 | 0507 | Technische Änderungen vorbehalten | Technical details subject to change

Typenspezifische Anlagen Type specific System

Pedal Interface II

Pedal Interface II

Die Anlage besteht aus:

The system is consisting of:

Pos.	Toyota RAV4 (ALA30), Modell 2006, 2,2L Diesel / 100kW / (2AD), Manual Transmission	A2C59511490
1	Elektronischer Regler / Electronic Control Unit Für Ersatzbedarf muß der Regler durch autorisierte Stelle programmiert werden For replacement the ECU must be programmed by an authorised workshop File name: RAV4 D4D 2.2l 100kw MT MY06 Tempostat.P2U	X39-737-100-001
2	Kabelbaum Spannungsversorgung / Power Supply Harness	A2C59510984
3	Kabelbaum Pedal / Pedal Harness	A2C59510983
4	Bedienungsanleitung / Operating instruction	TU00-0050-5110591
5	Bedienhebel / Control Stalk	X39-737-300-005

Pos.	Toyota RAV4 (ACA30), Modell 2006, 2,0L Petrol / 112kW / (1AZ), Manual Transmission	A2C59511491
1	Elektronischer Regler / Electronic Control Unit Für Ersatzbedarf muß der Regler durch autorisierte Stelle programmiert werden For replacement the ECU must be programmed by an authorised workshop File name: RAV4 2l petrol 112kw MT MY06 TEMPOSTAT.P2U	X39-737-100-001
2	Kabelbaum Spannungsversorgung / Power Supply Harness	A2C59510984
3	Kabelbaum Pedal / Pedal Harness	A2C59510983
4	Bedienungsanleitung / Operating instruction	TU00-0050-5110591
5	Bedienhebel / Control Stalk	X39-737-300-005
6	Kupplungsschalter / Clutch Switch	A2C59511557

Pos.	Toyota RAV4 (ACA30), Modell 2006, 2,0L Petrol / 112kW / (1AZ), Automatic Transmission	A2C59511492
1	Elektronischer Regler / Electronic Control Unit Für Ersatzbedarf muß der Regler durch autorisierte Stelle programmiert werden For replacement the ECU must be programmed by an authorised workshop File name: RAV4 2l petrol 112kw AT MY06 TEMPOSTAT.P2U	X39-737-100-001
2	Kabelbaum Spannungsversorgung / Power Supply Harness	A2C59510984
3	Kabelbaum Pedal / Pedal Harness	A2C59510983
4	Bedienungsanleitung / Operating instruction	TU00-0050-5110591
5	Bedienhebel / Control Stalk	X39-737-300-005

Typenspezifische Anlagen Type specific System

Pedal Interface II

Pedal Interface II

Die Anlage besteht aus:

The system is consisting of:

Pos.	Toyota Yaris (KSP90), Modell 2006, 1,0L Petrol / 51kW / (2SZ), Manual Transmission	A2C59511493
1	Elektronischer Regler / Electronic Control Unit Für Ersatzbedarf muß der Regler durch autorisierte Stelle programmiert werden For replacement the ECU must be programmed by an authorised workshop File name: Yaris KSP 90 1-0L petrol 51KW MT MY06 TEMPOSTAT.P2U File name: Yaris ZSP90 1.8l 98kw petrol MT MY07 TEMPOSTAT.P2U	X39-737-100-001
2	Kabelbaum Spannungsversorgung / Power Supply Harness	A2C59510984
3	Kabelbaum Pedal / Pedal Harness	A2C59510983
4	Bedienungsanleitung / Operating instruction	TU00-0050-5110591
5	Bedienhebel / Control Stalk	X39-737-300-005
6	Kupplungsschalter / Clutch Switch	A2C59511557

Pos.	Toyota Yaris (SCP90), Modell 2006, 1,3L Petrol / 64kW / (1SZ), Manual Transmission Toyota Yaris (ZSP90), Modell 2006, 1,8L Petrol / 98kW / (1ZR), Manual Transmission	A2C59511494
1	Elektronischer Regler / Electronic Control Unit Für Ersatzbedarf muß der Regler durch autorisierte Stelle programmiert werden For replacement the ECU must be programmed by an authorised workshop File name: Yaris SCP90 1.3L petrol 64KW MT MY06 TEMPOSTAT.P2U	X39-737-100-001
2	Kabelbaum Spannungsversorgung / Power Supply Harness	A2C59510984
3	Kabelbaum Pedal / Pedal Harness	A2C59510983
4	Bedienungsanleitung / Operating instruction	TU00-0050-5110591
5	Bedienhebel / Control Stalk	X39-737-300-005
6	Kupplungsschalter / Clutch Switch	A2C59511557

Pos.	Toyota Yaris (NLP90), Modell 2006, 1,4L Diesel / 66kW / (1ND), Manual Transmission	A2C59511495
1	Elektronischer Regler / Electronic Control Unit Für Ersatzbedarf muß der Regler durch autorisierte Stelle programmiert werden For replacement the ECU must be programmed by an authorised workshop File name: Yaris NLP90 D4D 1.4L 66KW MT MY06 TEMPOSTAT.P2U	X39-737-100-001
2	Kabelbaum Spannungsversorgung / Power Supply Harness	A2C59510984
3	Kabelbaum Pedal / Pedal Harness	A2C59510983
4	Bedienungsanleitung / Operating instruction	TU00-0050-5110591
5	Bedienhebel / Control Stalk	X39-737-300-005

Datenblätter für Pedal Interface II

Data Sheets For Pedal Interface II

Änderungsübersicht / Change Overview

Datum Date	Produktgruppe / Product Line Doku-Nr. / Documentation No.	Seite Page	Bemerkung Comment
0105	Regelelektronik / Electronic Controller TU00-0050-5204620	2	neu / new: Technische Daten / Technical Data: Gutachten / Expertise
0205	Einbausatz / Installation Kit TU00-0050-5304620	1	neu / new: Mindest Bestellmenge / minimum order quantity
	Kupplungsschalter / Clutch Switch TU00-0050-5904620	1	neu / new: Mindest Bestellmenge / minimum order quantity
	Kupplungsschalter, berührungslos Clutch Switch, contact less TU00-0050-6004620	1	neu / new: Mindest Bestellmenge / minimum order quantity
0305	Standard Bedienhebel / Standard control stalk TU00-0050-6104620	1	X11-708-002-023 war / was X11-737-002-007 6x war / was 4x X11-708-002-027 war / was X11-737-002-001
	LED Bedienhebel rechts / LED control stalk right hand TU00-0050-6204620	1	X11-708-002-023 war / was X11-737-002-007 X11-708-002-027 war / was X11-737-002-002
	LED Bedienhebel links / LED control stalk left hand TU00-0050-6304620	1	X39-397-106-069 war / was X11-737-002-001 X11-708-002-022 war / was X11-737-002-006
	Bedienhebel rechts, flexibel / Flexible control stalk right hand TU00-0050-6404620	1	
	Bedienhebel links, flexibel / Flexible control stalk left hand TU00-0050-6504620	1	
0505	Kupplungsschalter, berührungslos Clutch Switch, contact less TU00-0050-6004620	1	Mindest Bestellmenge / minimum order quantity X39-397_106_128 war / was 10
0806	komplett / complete	—	neu / new: Corporate Design
0507	Universelle Anlagen / Universal Systems TU00-0050-5104620	1, 2	neu / new: Bedienungsanleitung / Operating Instructions Universelle Anlagen / Universal Systems
	Typenspezifische Anlage / Type specific system TU00-0050-6604620	—	neu / new: komplett / complete
	Typenspezifische Anlage / Type specific system TU00-0050-6604620	2, 6, 7	A2C59511557 war / was X39-737-300-013
0707	Typenspezifische Anlage / Type specific system TU00-0050-6604620	8, 9	Toyota Hilux neu / new
0807	Installation Kit Clutch Switch, round (M10x1) / Einbausatz Kupplungsschalter, rund (M10x1) TU00-0050-67604620	—	neu / new: komplett / complete
0807	Installation Kit LED 12 VDC Green / Einbausatz LED 12 VDC Green TU00-0050-68604620	—	neu / new: komplett / complete

