

PLAN VIEW

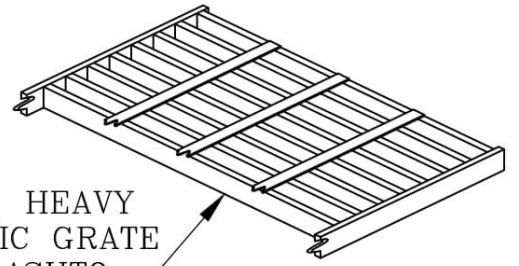

GRATING

NOTES:

BOX FABRICATED FROM  
10 GA. MATERIAL

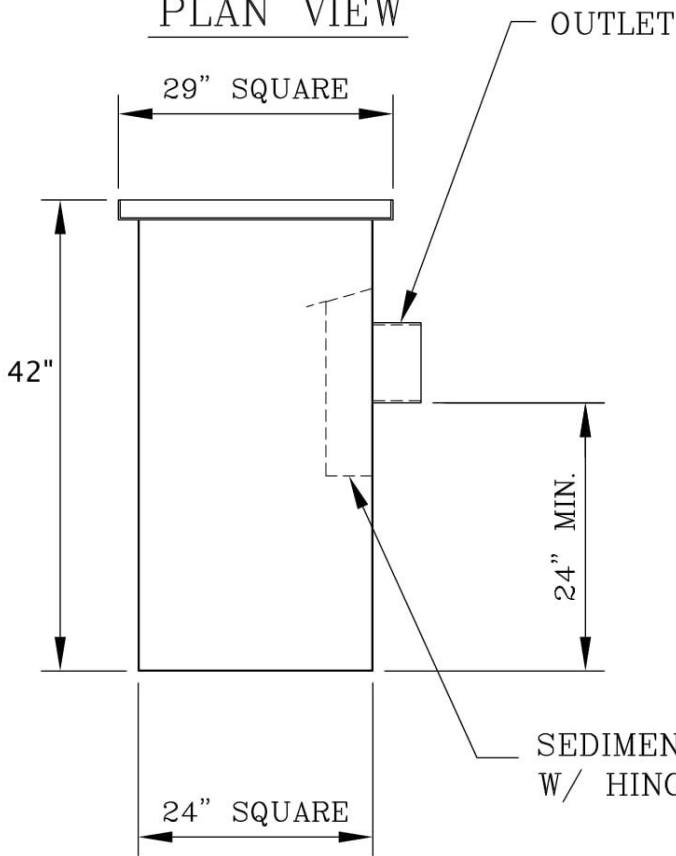

SIDE VIEW

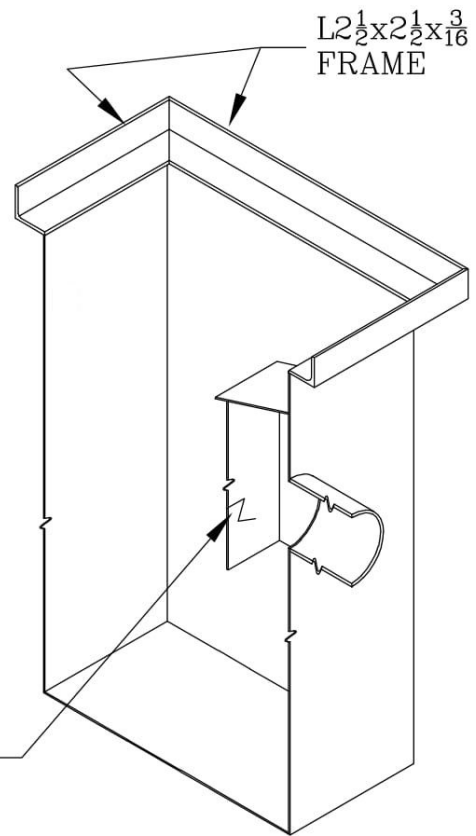

ISOMETRIC SECTION

STATE APPROVED — ASPHALT DIPPED

24" SQUARE — 4"Ø OR 6"Ø OR 8"Ø OUTLET

STORM WATER CATCH BASIN

MODEL: MPCB10-42HB-4&6&8

DATE: 11/19/2020

SCALE: NONE

DWG #

**T1**

**Gibson Steel Basins, Inc.**

1040 Arrowsmith St. Eugene Or. 97402  
(541) 484-7200 or (800) 574-8096

Visit us at: [www.gibsonsteelbasins.com](http://www.gibsonsteelbasins.com)  
Email us at: [sales@gibsonsteelbasins.com](mailto:sales@gibsonsteelbasins.com)

EST. 1996

CCB 150089