

INDUSTRIAL DIESEL ENGINE

KUBOTA 03 SERIES (3-cylinder)

D1803-CR-E4B

RATED POWER

28.0kW @ 2700rpm

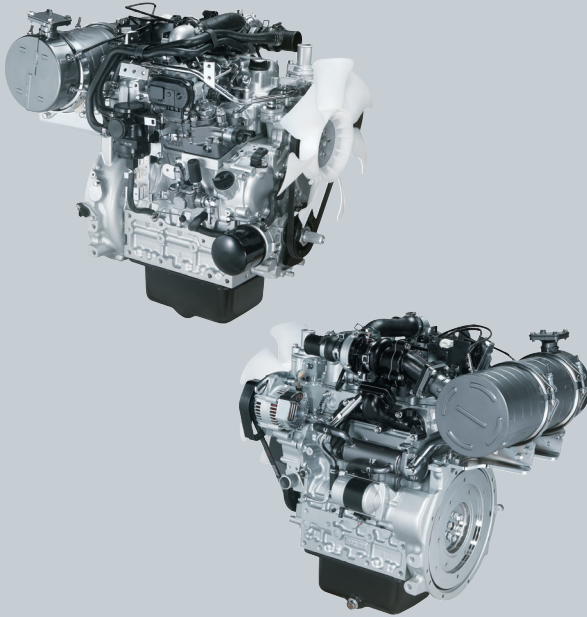

Turbo version Shown.
Photographs may show non-standard equipment.

PERFORMANCE CURVE

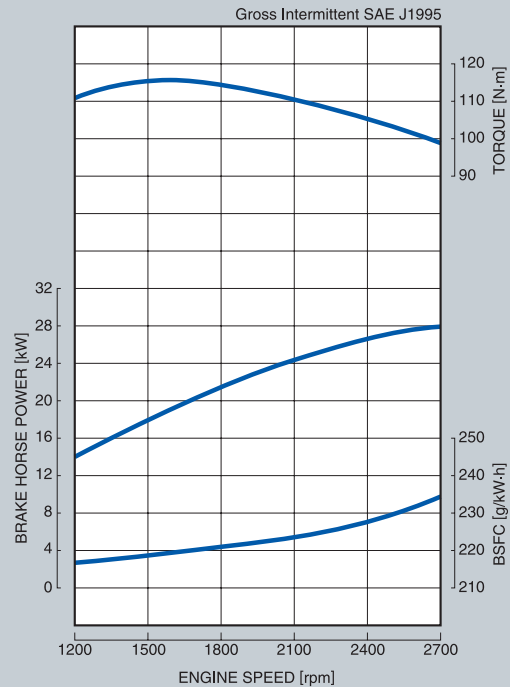

FEATURES and BENEFITS

Proven Reliability and New Technology

The latest technology and a strong performance – two things customers expect from Kubota engines. We continue to provide both by seeking excellence in three key areas: emission compliance, new strides in fully electronic controlled engines, and flexibility in products and services to customers worldwide.

Emission Compliance

Meeting rigid emission regulations can be a challenge for any company. At Kubota, our 03 Series engines have been designed to comply with the most stringent regulations: The EPA Tier4 and the EU Stage III A. In addition, innovative emission solutions, such as an aftertreatment device, have also been integrated into the 03 Series engines.

Clean and Quiet Power

The Common Rail System has made it possible to optimize combustion and create a more durable, quiet, and improved fuel-economy engine. By meticulously screening and controlling the exhaust gas aftertreatment components, Diesel Oxidation Catalyst (DOC) and Diesel Particulate Filter (DPF), we offer a cleaner high-performance engine.

Flexibility

When working with customers in different countries and with different engine needs, flexibility is a must. Since Kubota 03 Series engines have evolved step-by-step to meet every EPA Tier, we provide the appropriate emission regulation certified engine to any customers worldwide. Added to that, we have designed aftertreatment device with minimum package impact for easy installation.

Trust

The Kubota 03 Series is the best solution for your company's global marketing strategy. We continuously strive to meet your needs with the experience and expertise you expect and deserve.

KUBOTA 03 SERIES D1803-CR-E4B

GENERAL SPECIFICATION

Model		D1803-CR-E4B
Emission Regulation		Tier4 / Stage III A
Type		Vertical 4-cycle liquid cooled Diesel
Number of Cylinders		3
Bore	mm (in)	87.0 (3.43)
Stroke	mm (in)	102.4 (4.03)
Displacement	L (cu.in)	1.826 (111.43)
Combustion System		DI
Intake System		Naturally Aspirated
Maximum Speed	rpm	2700
Output: Gross Intermittent	kW	28.0
	hp	37.5
	ps	38.1
Direction of Rotation		Counter clockwise Viewed on Flywheel
Oil Pan Capacity	L (gal)	7.0 (1.8)
Starter Capacity	V-kW	12-2.0
Alternator Capacity	V-A	12-60
Length	mm (in)	744.0 (29.30)
Width	mm (in)	507.0 (20.00)
Height	mm (in)	721.0 (28.40)
Dry Weight	kg (lb)	185.0 (408.0)

*Specification is subject to change without notice.

*Output: Gross Intermittent SAE J1995

*Dry weight is according to Kubota's standard specification.
When specification varies, the weight will vary accordingly.

DIMENSIONS

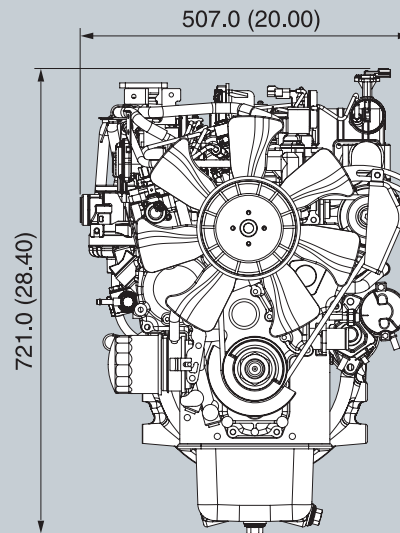
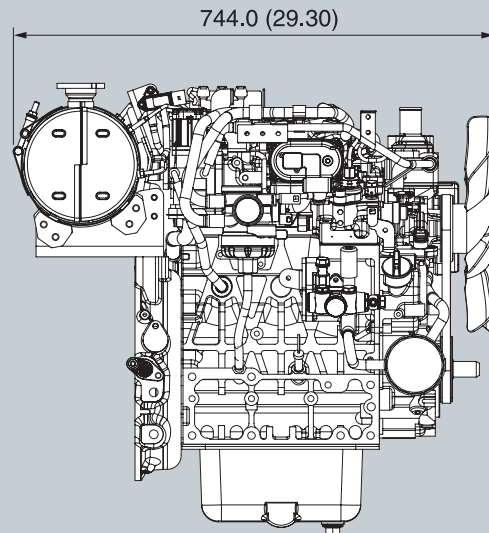

Final weight and dimension will depend on completed specification.



KUBOTA Engine America Corporation

505 Schelton Road, Lincolnshire, IL 60069

Phone: 847-955-2500 Fax: 847-955-2699

www.kubotaengine.com