



M-K POWER PRODUCTS CORP.
 3500 Laird Road, Unit 2
 Mississauga, Ontario
 L5L 5Y4

800 263-5011
 www.M-K.com

ZPP NA 665

6 Cylinder Inline | Naturally-Aspirated |
 6.5L - Natural Gas, Propane, Dual Fuel |

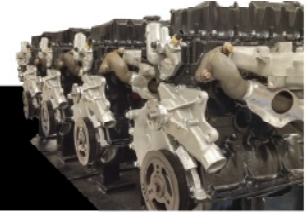

Specifications

# of Cylinders	6 Inline
Operation	4-stroke
Ignition	Spark-Ignited
# of Valves	4/cylinder
Firing Order	1-5-3-6-2-4
Bore x Stroke	105 X 124 mm 4.134" x 4.882"
Displacement	6.5 L / 396.7 ci
Compression Ratio	11.1 : 1
Dry Weight	500 kg / 1100 lbs
Piston Speed @ 2300 rpm	1871 fpm
Piston Speed @ 1800 rpm	1465 fpm
Oil Capacity	17.0 L / 18.0 qts
Electrical System	Combined 12/24 Volt

Standard Features

☆	US EPA Certified
☆	CAN bus controlled—J1939
☆	Full Built-in Engine Protection
☆	SAE #3 Housing
☆	SAE 11.5" Flywheel
☆	Replaceable Dry Liners

Optional Features

☆	Customer Specific Packaging
☆	Turn-Key Enclosures

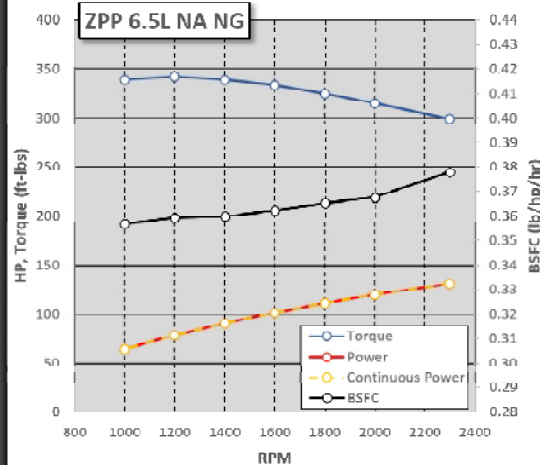

Rating	Industrial Rating (bHP)		Genset Rating (kWe)
	2300 rpm	1800 rpm	1800 rpm
Intermittent	131.0	111.0	76
Prime	131.0	111.0	76
Continuous	131.0	111.0	76

*All data is corrected per SAE J1349
 *Performance is Net including losses from auxiliaries (alternator, fan, water pump)
 *NG is pipeline grade gas
 *LPG is Commercial grade
 *Gasoline is pump gasoline
 *Electrical kW is calculated using a 92%

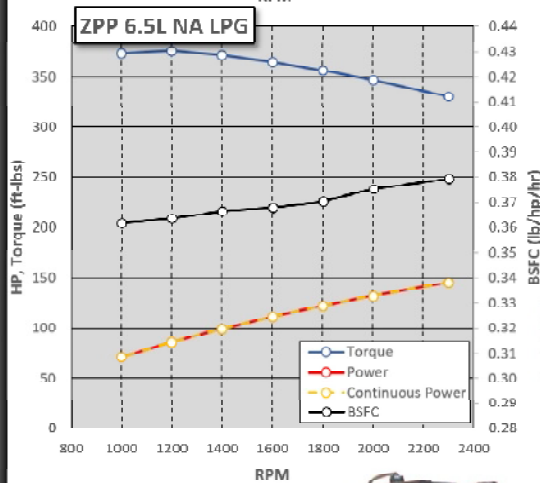

Rating	Industrial Rating (bHP)		Genset Rating (kWe)
	2300 rpm	1800 rpm	1800 rpm
Intermittent	145.0	122.0	84
Prime	145.0	122.0	84
Continuous	145.0	122.0	84





M-K POWER PRODUCTS CORP.

3500 Laird Road, Unit 2
Mississauga, Ontario
L5L 5Y4

800 263-5011
www.M-K.com

Fuel System Features

- ☆ Natural Gas, LPG, or Dual Fuel
- ☆ Air-valve Mixer based fueling
- ☆ Electronic, closed-loop control
- ☆ EPA certified to pipeline quality fuels
- ☆ Electronic Throttle body
- ☆ Inline catalyst provided with engine

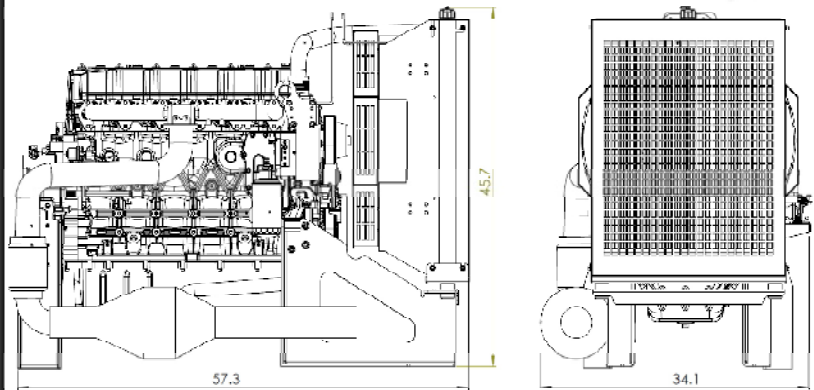

*All data is corrected per SAE J1349

Pipeline NG

RPM	Torque ft-lbs (Nm)	Power BHP (kW)	BMEP (psi)	Fuel Flow (lb/hr)	Air Flow (lb/hr)	BSFC (lb/hp/hr)	Exhaust Outlet (F)
2300	299 (406)	131 (98)	107	49.5	812.5	0.378	1,300
2000	316 (428)	120 (90)	112	44.2	724.2	0.367	1,290
1800	325 (441)	111 (83)	116	40.7	667.7	0.365	1,261
1600	334 (453)	102 (76)	119	36.8	604.1	0.362	1,238
1400	339 (460)	90 (67)	121	32.5	533.4	0.360	1,215
1200	342 (464)	78 (58)	122	28.1	461.0	0.359	1,180
1000	339 (460)	65 (48)	121	23.0	378.0	0.357	1,134

Commercial LPG

RPM	Torque ft-lbs (Nm)	Power BHP (kW)	BMEP (psi)	Fuel Flow (lb/hr)	Air Flow (lb/hr)	BSFC (lb/hp/hr)	Exhaust Outlet (F)
2300	331 (448)	145 (108)	118	54.9	860.2	0.379	1,335
2000	347 (470)	132 (98)	124	49.5	775.8	0.375	1,324
1800	356 (483)	122 (91)	127	45.2	708.4	0.370	1,295
1600	365 (495)	111 (83)	130	40.9	640.9	0.368	1,270
1400	372 (504)	99 (74)	132	36.3	568.4	0.366	1,238
1200	376 (510)	86 (64)	134	31.2	489.1	0.364	1,204
1000	374 (71)	71 (53)	133	25.7	403.1	0.362	1,160