



**M-K POWER PRODUCTS CORP.**  
 3500 Laird Road, Unit 2  
 Mississauga, Ontario  
 L5L 5Y4

800 263-5011  
 www.M-K.com

# ZPP NA 857

8 Cylinder Vee | Naturally-Aspirated |  
 5.7L - Natural Gas, Propane, Dual Fuel |



## Specifications

# of Cylinders	8 Vee
Operation	4-stroke
Ignition	Spark-Ignited
# of Valves	2/cylinder
Firing Order	1-8-4-3-6-5-7-2
Bore x Stroke	101.6 X 88.4 mm 4.000" x 3.480"
Displacement	5.7 L / 349.7 ci
Compression Ratio	9.4 : 1
Dry Weight	204 kg / 450 lbs
Piston Speed @ 2600 rpm	1,508 fpm
Piston Speed @ 1800 rpm	1,044 fpm
Oil Capacity	4.73 L / 5.0 qts
Electrical System	12 Volt

## Standard Features

☆	US EPA Certified
☆	CAN bus controlled—J1939
☆	Full Built-in Engine Protection
☆	Stoichiometric Combustion
☆	Cast Iron block and head

## Optional Features

☆	Customer Specific Packaging
☆	Turn-Key Enclosures

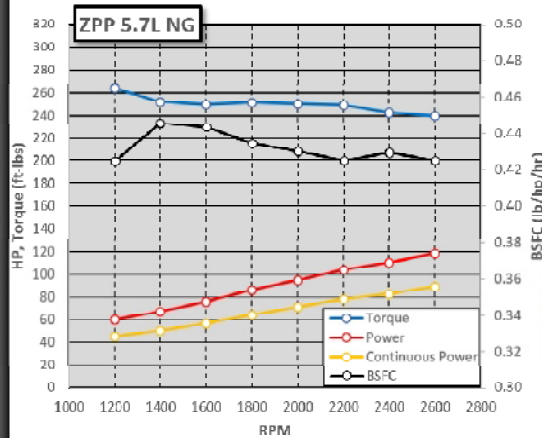

	Industrial Rating (bHP)		Genset Rating (kWe)
Rating	2600 rpm	1800 rpm	1800 rpm
Intermittent	119	86	60
Prime	107	78	53
Continuous	89	65	44

\*All data is corrected per SAE J1349  
 \*Performance is Net including losses from engine auxiliaries (alternator, fan, water pump, air cleaner, catalysis)  
 \*NG is pipeline grade gas  
 \*LPG is commercial grade  
 \*Gasoline is pump gasoline  
 \* Electrical kW calculated with 92%

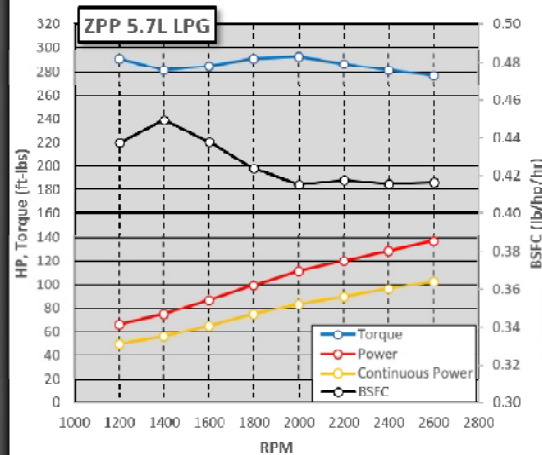

	Industrial Rating (bHP)		Genset Rating (kWe)
Rating	2600 rpm	1800 rpm	1800 rpm
Intermittent	137	100	68
Prime	123	90	62
Continuous	103	75	51

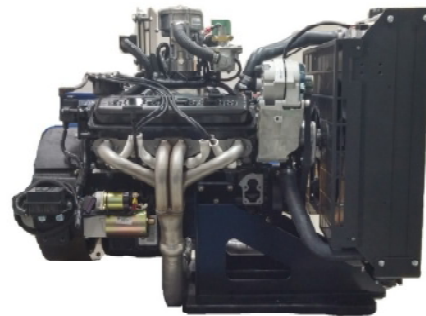



**M-K POWER PRODUCTS CORP.**

3500 Laird Road, Unit 2  
Mississauga, Ontario  
L5L 5Y4

800 263-5011  
www.M-K.com

### Fuel System Features

- ☆ Natural Gas, LPG, or Dual Fuel
- ☆ Air-valve Mixer based fueling
- ☆ Electronic, closed-loop control
- ☆ EPA certified to pipeline quality fuels
- ☆ Electronic Throttle body
- ☆ Inline catalyst provided with engine

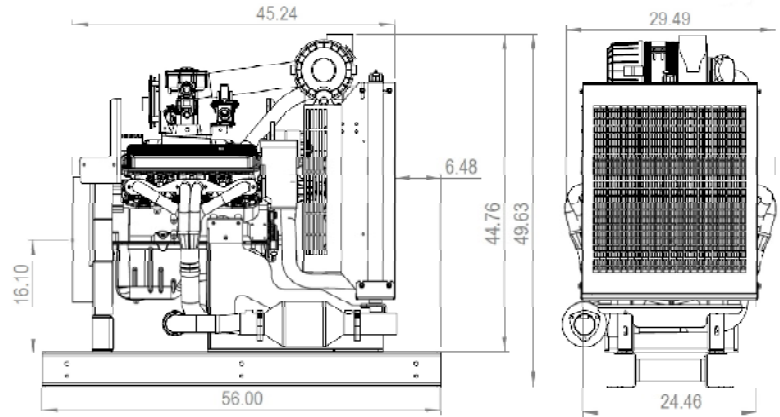

\*All data is corrected per SAE J1349

Pipeline NG

RPM	Torque ft-lbs (Nm)	Power BHP (kW)	BMEP (psi)	Fuel Flow (lb/hr)	Air Flow (lb/hr)	BSFC (lb/hp/hr)	Exhaust Outlet (F)	Exhaust Mass Flow (lb/hr)
2600	240 (325)	119 (89)	94.2	46.0	754.3	0.425	1,415	784
2400	243 (329)	111 (83)	95.3	43.4	711.3	0.429	1,389	739
2200	249 (338)	104 (78)	97.9	40.4	662.7	0.425	1,359	689
2000	250 (339)	95 (71)	98.2	37.3	611.7	0.430	1,325	634
<b>1800</b>	<b>252 (341)</b>	<b>86 (64)</b>	<b>98.8</b>	<b>34.1</b>	<b>559.7</b>	<b>0.434</b>	<b>1,292</b>	<b>580</b>
1600	250 (339)	76 (57)	98.1	30.7	504.2	0.444	1,244	521
1400	252 (342)	67 (50)	99.0	27.3	447.2	0.446	1,173	461
1200	264 (359)	60 (45)	103.8	23.4	383.3	0.425	1,096	395

Commercial LPG

RPM	Torque ft-lbs (Nm)	Power BHP (kW)	BMEP (psi)	Fuel Flow (lb/hr)	Air Flow (lb/hr)	BSFC (lb/hp/hr)	Exhaust Outlet (F)	Exhaust Mass Flow (lb/hr)
2600	277 (375)	137 (102)	108.7	52.0	813.6	0.416	1,412	854
2400	282 (382)	129 (96)	110.5	48.7	762.2	0.416	1,390	802
2200	287 (389)	120 (90)	112.5	45.6	714.8	0.418	1,356	752
2000	293 (397)	111 (83)	114.9	42.2	660.1	0.415	1,318	691
<b>1800</b>	<b>291 (395)</b>	<b>100 (74)</b>	<b>114.3</b>	<b>38.5</b>	<b>602.3</b>	<b>0.423</b>	<b>1,285</b>	<b>629</b>
1600	285 (387)	87 (65)	111.9	34.6	542.4	0.438	1,241	566
1400	282 (382)	75 (56)	110.6	30.7	481.1	0.449	1,180	501
1200	291 (395)	67 (50)	114.3	26.5	414.9	0.438	1,110	431

**POWERED by**

