

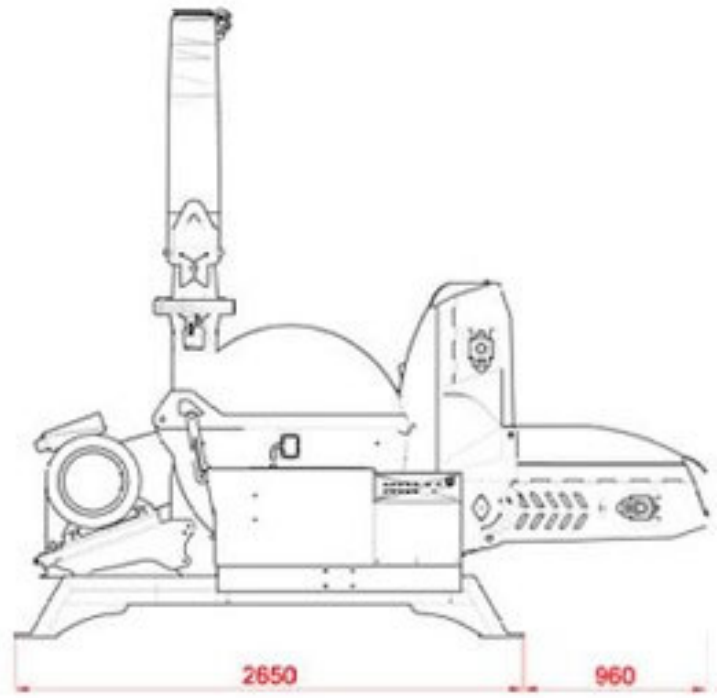

### SM5025E TECHNICAL SPECS

<b>Max. Diameter of Log</b>	Ø250 mm
<b>Feed Table Width</b>	520 mm
<b>Feed Table Length</b>	1500 mm
<b>Bunker Neck Entrance</b>	300 x 560mm
<b>Drum Diameter</b>	Ø540 mm
<b>Drum Length</b>	500 mm
<b>Fixed Blade</b>	1 piece
<b>Rotating Blades</b>	6 pieces
<b>Speed range</b>	800 rpm
<b>Capacity</b>	Min 10m <sup>3</sup> /hour
<b>Chute Rotation Angle</b>	270 °
<b>Weight</b>	4000 kg
<b>Drive System</b>	Intermittent system with hydraulic speed control
<b>Min Motor Power</b>	55 kW
<b>Operating Voltage</b>	380V

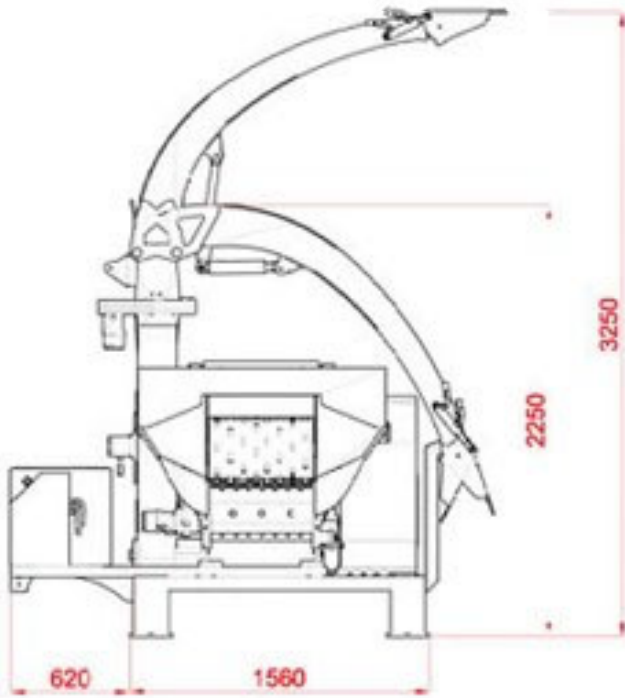

**Agrotech**  
**Automation** **1300 284 268**  
[www.agro-tech.com.au](http://www.agro-tech.com.au)