



Hawk Lift

optimize reaching

5333A

A high quality trailer boom lift with the most modern control technology and excellent work performance

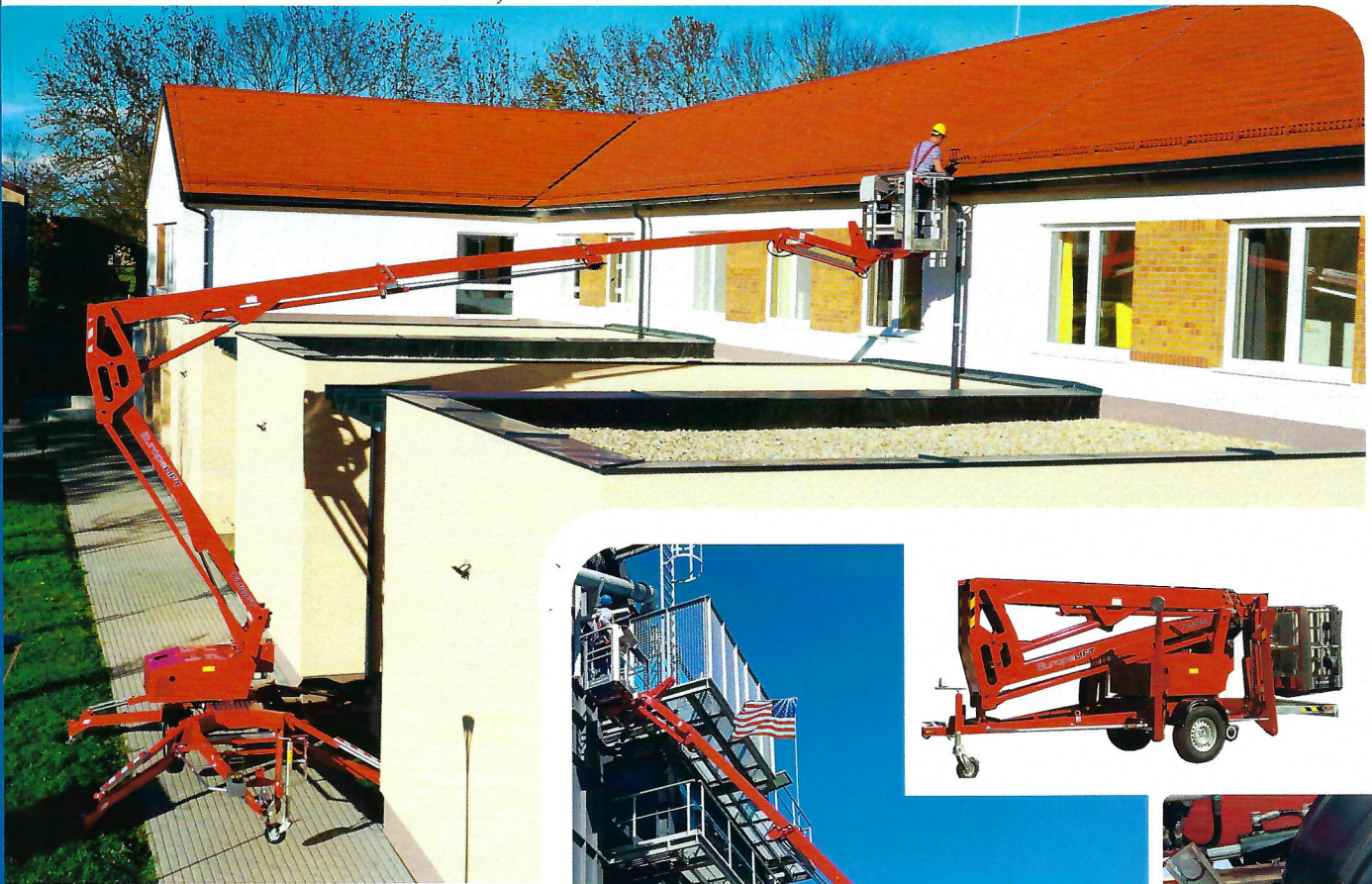

- Working Height: 59 ft 5 in
- Max. Platform capacity 485 lbs
- Max. outreach: 34 ft 5 in (220 lbs)
- Articulated construction with three section telescopic upper boom.
- Upper control box with LCD-display, plus wifi remote live service diagnostic (standard)
- Auto home function (standard)
- Gasoline engine (Honda/Briggs) power source (standard)
- Auto level chassis (standard)
- Compact transport dimensions (Transport length 20 ft)

TRAILER MOUNTED BOOM LIFT



TYP: **5333A**

Technical data	5333A
Working Height	59 ft 5 in
Platform Height	52 ft 10 in
Max. horizontal Reach	(220 lbs) app.34 ft 5 in
Max. horizontal Reach	(485 lbs) 26 ft 6,9 in
Max. Platform Capacity	485 lbs
Platform Rotation	355°
Flyjib	4 ft 3 in
Platform Dimensions	3 ft 11 in x 2 ft 7,5 in x 3 ft 7 in
Platform Rotation	2x45°
Transport Length	20 ft
Transport Width	5 ft 5 in
Transport Height	6 ft 11 in
Total Weight 230V & Gasoline engine, wheel assist, platform rotator	4475 lbs
Wheel assist	Standard
Outrigger footprint (width)	12 ft 7 in (plate outer edge)
Gradeability	10%
Max. Speed	50 m/h
Tongue weight	220 lbs
Energy chain	Inside profile

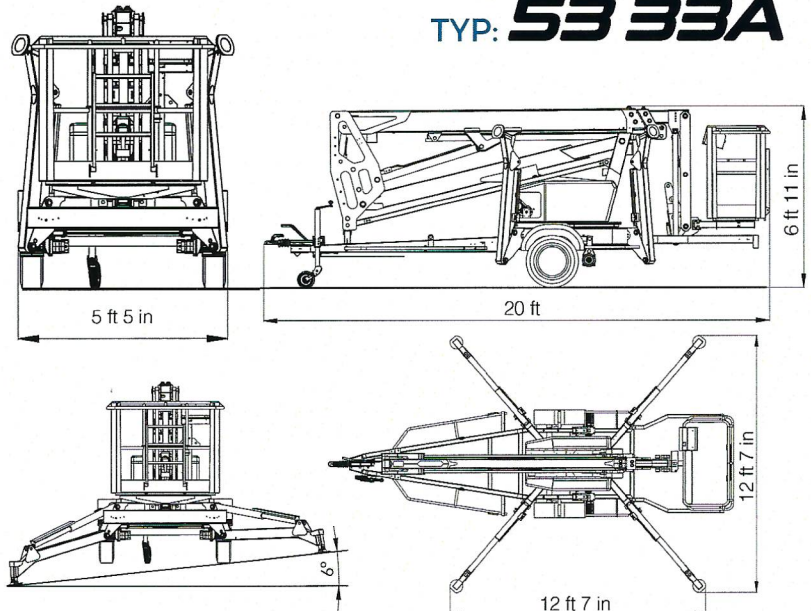

STANDARD FEATURES

- Articulated construction with 3-section telescope upper boom system with moment control system
- 4 ft 3 in flyjib
- Autohome and Platform rotator
- Platform leveling with 3° Auto adjust
- Alu basket with guard rail and tool tray
- Platform controls with LCD function display, plus Wifi remote live service diagnostics
- Proportional, electro-hydraulic fine control by fingertip joysticks
- Horn and Anti-Collision control
- Ground and platform control
- Chassis monitoring with 1° with acoustic. warning signal
- Ground pressure monitoring on outrigger plates with acoustic and visual warning signal
- Protective cover on upper control box
- Rear LED light support frame

OPTIONS

- Custom colour
- Battery power source 24V 220Ah
- Dual power source 24V DC & gasoline engine
- GRP work platform with tool tray
- 1,3 x 1,3 x 0,1 ft plastic outrigger pads
- Air & water line to platform
- Stroboscope warning lights on outriggers
- AC wiring power line to the platform, hour meter
- Wheel assist with hydraulic coupling
- Hydraulic speed control of the engine

