

LED Barn Light

naturaLED®

ECO STREAMS®

naturaLED® offers our newest temporary work light providing high performance, long lifespan and energy savings for illuminating large industrial, construction and outdoor areas. It is a great replacement or upgrade choice for existing HID, Metal Halide, CFL work light. It is designed to combine the professional brightness intensity of industry-graded high bay fixtures with the convenience of a portable work light. This product is the perfect choice for temporary lighting on new and existing construction sites, short-term maintenance tasks, and warehouses, factories and workshops, highway toll stations, gas stations, exhibition halls.



SKU#: 4555
Model: LED60TL/FR66/850

- ▶ IP64 UL listed
- ▶ LED 60W, 120Vac, 50/60Hz
- ▶ Linkable with built-in connector
- ▶ 6600 Lumen, CCT 5000K
- ▶ Net Weight: 3.75 lbs
- ▶ Material: Durable stainless steel lamp guard

Warranty: 5yrs



Dimensions

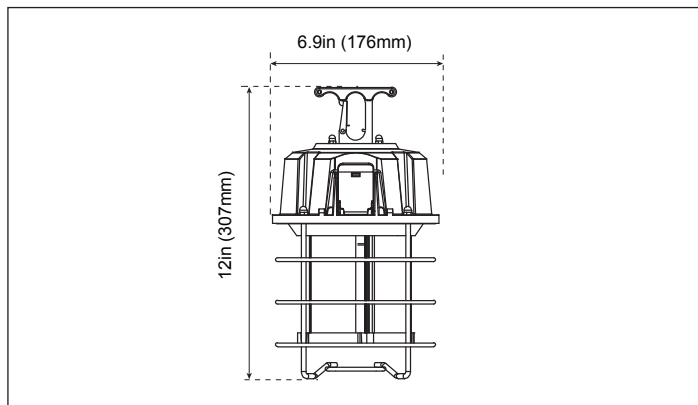

Photometric Chart

