

OUTLINE FOR ASCO® 300 SERIES TRANSFER SWITCHES (D3ATS,D3NTS) 30-230 AMPERES OPEN TYPE

GENERAL NOTES

1. THE STANDARD SWITCH CONFIGURATION IS FOR TOP EMERGENCY & LOAD AND BOTTOM NORMAL.
2. NEUTRAL CONFIGURATIONS:
AN OPTIONAL FULL RATED NEUTRAL CONFIGURATION FOR EACH SOURCE AND THE LOAD MAY BE PROVIDED. WHEN EQUIPPED IT IS IN ONE OF THE FOLLOWING FORMATS AS SPECIFIED BY THE CATALOG NUMBER NO. NEUTRAL TYPE:
(A) SOLID (COPPER BUS) NEUTRAL
(B) SWITCHED NEUTRAL POLE
(C) OVERLAPPING NEUTRAL POLE
3. THE STANDARD MECHANICAL (SCREW TYPE) AL/CU TERMINAL LUGS ARE SHOWN FOR REFERENCE.
4. SWITCHED NEUTRAL POLE IS SHOWN FOR REFERENCE ON PAGE TWO.
5. WHEN INSTALLING CONDUCTORS, CONNECT TO SIMILARLY MARKED PHASES OF NORMAL, EMERGENCY & LOAD.
6. ALL INTERNAL CONNECTIONS ARE MADE AT FACTORY.
7. MAINTAIN ELECTRICAL CLEARANCE OF .50" (12,7 mm) BETWEEN LIVE METAL PARTS AND GROUNDED METAL.
8. WHEN MOUNTING THE TRANSFER SWITCH IN AN ENCLOSURE, MOUNT THE TRANSFER SWITCH UNIT ON THE INSIDE BACK SURFACE OF THE ENCLOSURE. THE CONTROL(S) PANEL AND OPERATOR CONTROLS SHOULD BE MOUNTED ON THE INSIDE, REAR SURFACE OF THE DOOR. A MINIMUM DEPTH OF 6.00" (152,4mm) IS REQUIRED BETWEEN THE TRANSFER SWITCH AND THE DOOR WHEN THE DOOR IS CLOSED.
9. THE CONTROL PANEL(S) IS CONNECTED TO THE TRANSFER SWITCH BY A HARNESS WITH A QUICK DISCONNECT PLUG(S). THE HARNESS EXITS THE TRANSFER SWITCH ON THE RIGHT SIDE. CONSULT FACTORY FOR EXTENSION HARNESSES.
10. FOR TYPE 1 ENCLOSURE SEE DETAIL A -1 AND DETAIL B -1 FOR CUTOUT DATA. FOR TYPE 3R, 4, & 12 ENCLOSURE SEE DETAIL A -2 AND DETAIL B -2 FOR CUTOUT DATA. GASKETS ARE PROVIDED FOR TYPE 3R, 4, & 12 ENCLOSURES. A BEZEL FOR THE CONTROL PANEL IS ALSO PROVIDED FOR TYPE 3R, 4, & 12 ENCLOSURES.
11. AN OPERATOR'S MANUAL IS FURNISHED WITH EACH AUTOMATIC TRANSFER SWITCH. REFER TO THIS PUBLICATION PRIOR TO INSTALLATION AND OPERATION OF THE SWITCH.
12. WHEN OPTIONAL OVERLAPPING NEUTRAL IS SUPPLIED THE CONTACTS ON THE OVERLAPPING NEUTRAL ARE REVERSED, NORMAL ON TOP, EMERGENCY AT BOTTOM.

MINIMUM REQUIRED ENCLOSURE SIZE IN(mm)

SWITCH RATING (AMPS)	HEIGHT	WIDTH	DEPTH
30-200 AMPS	31.00 (787,4)	17.50 (444,5)	11.63 (295,4)
230 AMPS	48.00 (1219,2)	18.00 (457,2)	13.00 (330,2)

APPROXIMATE SHIPPING WEIGHT, LBS (KG)
(WEIGHT INCLUDES STANDARD TRANSFER SWITCH & CONTROLS)

AMP SIZE	POLES	WEIGHT
30-230	2	17 (8)
	3	20 (9)
	3 W/ NEUTRAL POLE	23 (11)

SUGGESTED BOLT SIZE FOR MOUNTING A.T.S.:
1/4-20 X 1 INCH LONG MINIMUM QUANTITY (4)

SWITCH RATING (AMPS)	RANGE OF WIRE
30-150	(1) #14 TO 4/O AWG AL-CU WIRE
200-230	(1) #14 TO 4/O AWG COPPER WIRE

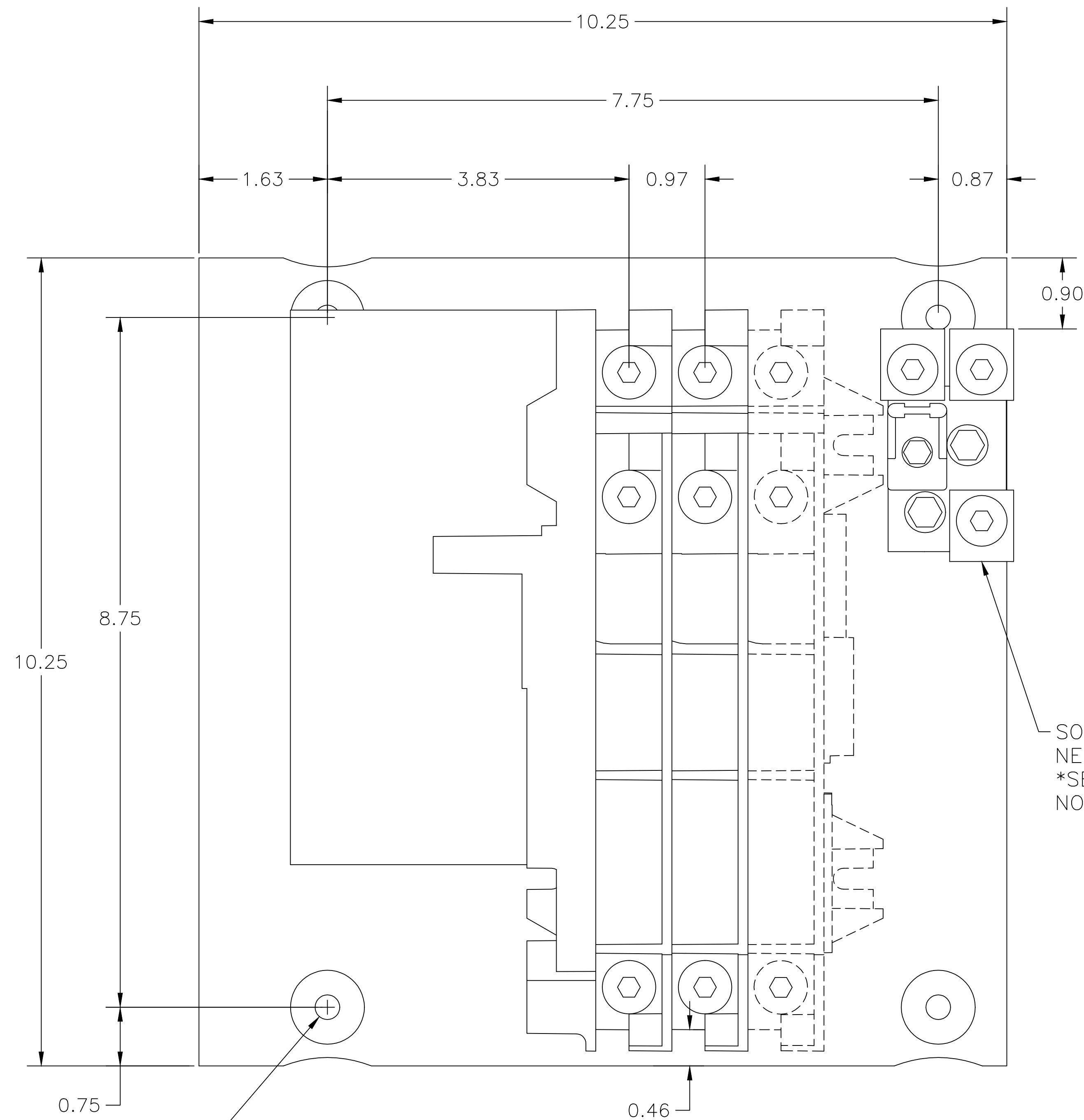
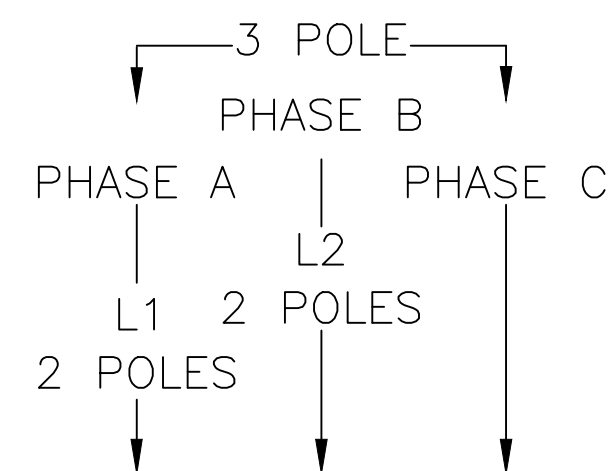

(FRONT VIEW)

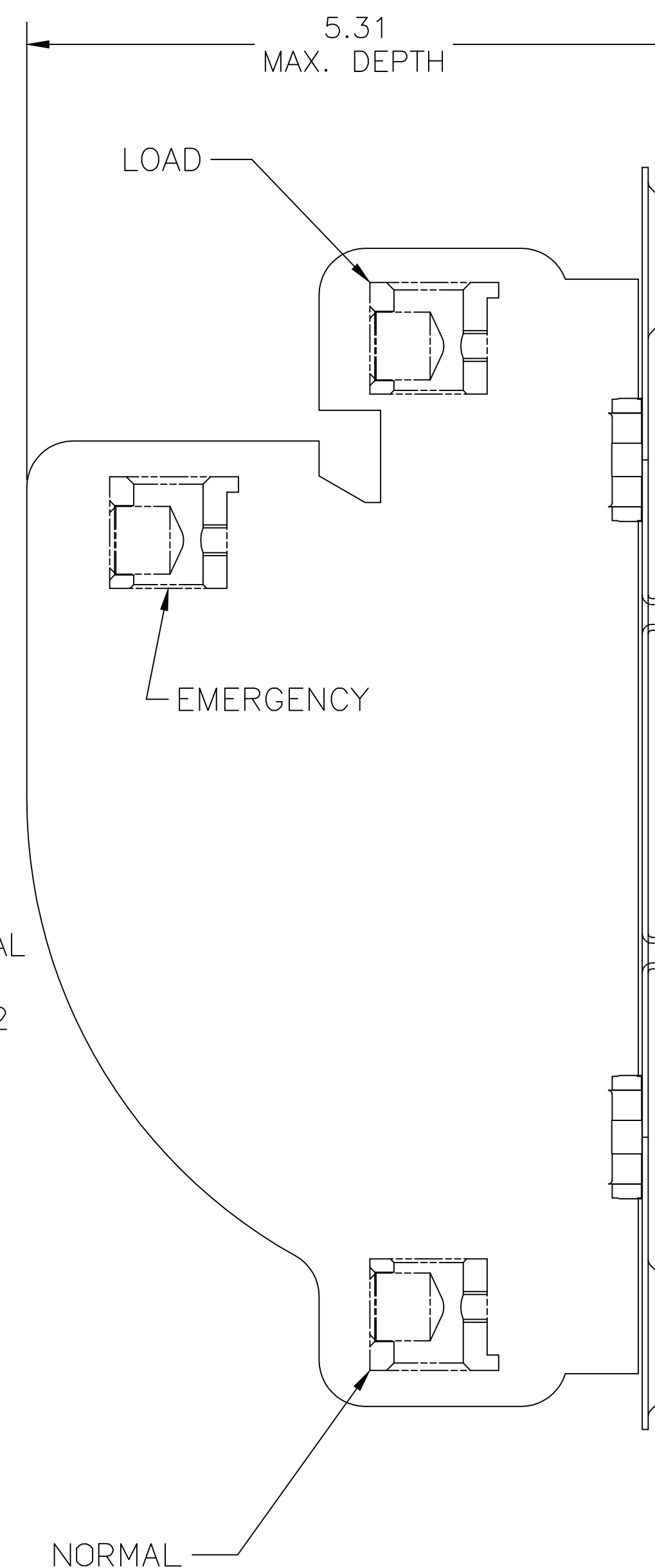

(SIDE VIEW)
*SOLID NEUTRAL NOT SHOWN

SOLID NEUTRAL
*SEE NOTE 2

B	251362	TR	BK	10/22/14
	SEE ECN			
A	249616	AE	BK	07/20/14
	SEE ECN			
-	245200	BWM	SDH	11/1/13
	ISSUED			

PROJECT NAME:		REV. TO SHEET	ECN NO.	BY	APP.	DATE
COMPOSITE OUTLINE						
300 SERIES, D3ATS/D3NTS RATED 30-230 AMPERES OPEN TYPE						
BY	DATE	MANUFACTURING TOLERANCES TO BE IN ACCORDANCE WITH ASCO PROCEDURE MP-1-003. FOR PLASTIC PARTS SEE MP-1-005		ASSEM. REF. NO.	COMPUTER GENERATED DRAWING	
DRAWN BY	BWM	11/1/13			SCALE	NO. SIZE DS
CHECKED			PROPERTY OF ASCO POWER TECHNOLOGIES. USE PERMITTED FOR OUR WORK ONLY. ALL RIGHTS OF DESIGN OR INVENTION ARE RESERVED.		DWG. NO.	
PROJECT APPROVAL					987723-002	
FINAL APPROVAL	SDH	11/1/13	ASCO ASCO POWER TECHNOLOGIES, L.P. FLORHAM PARK, NEW JERSEY 07932 U.S.A.		DRAWING B	ECN NO. 251362 SHEET 1 OF 3

OUTLINE FOR ASCO® 300 SERIES TRANSFER SWITCHES (D3ATS,D3NTS) 30-230 AMPERES OPEN TYPE

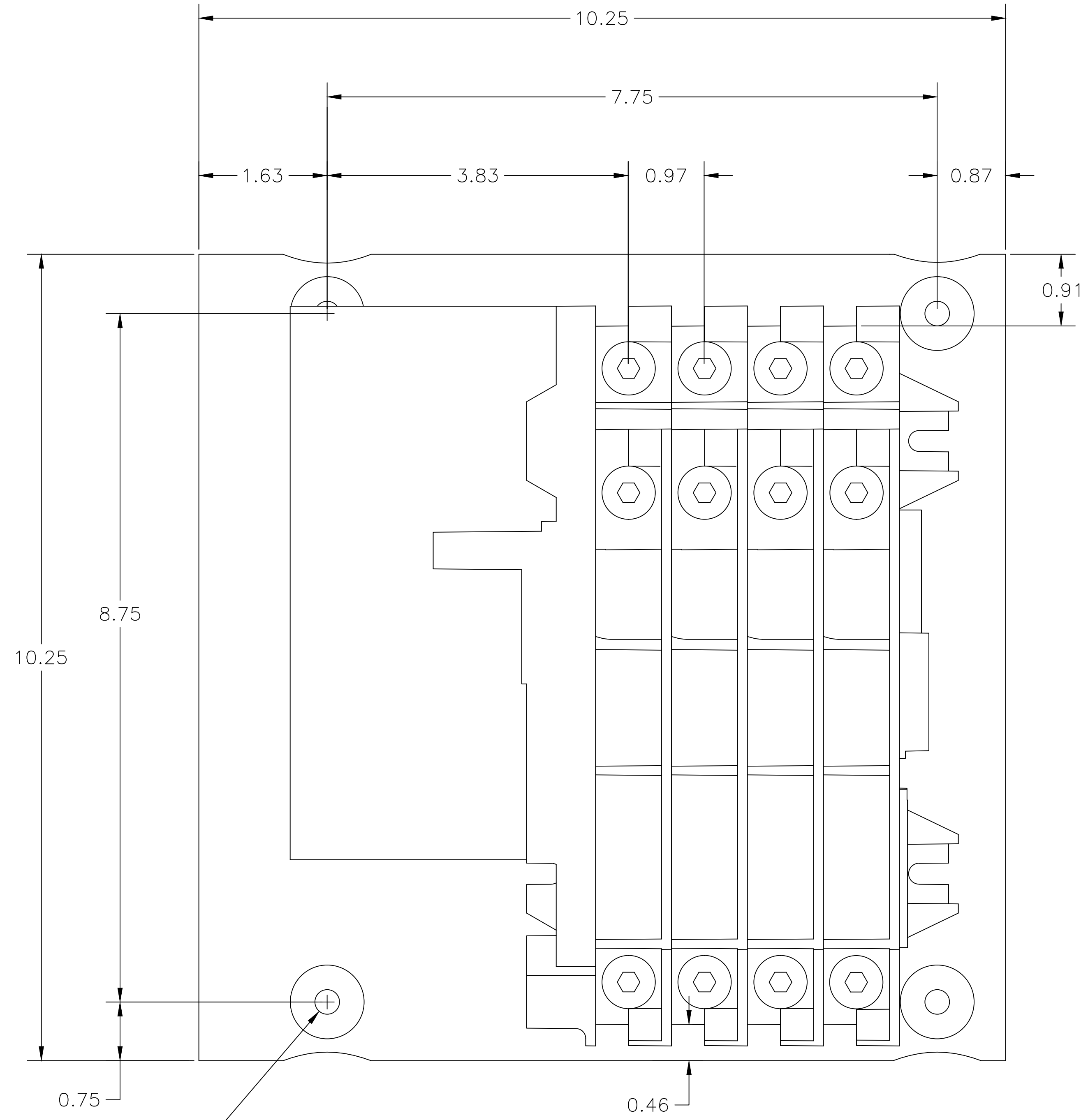
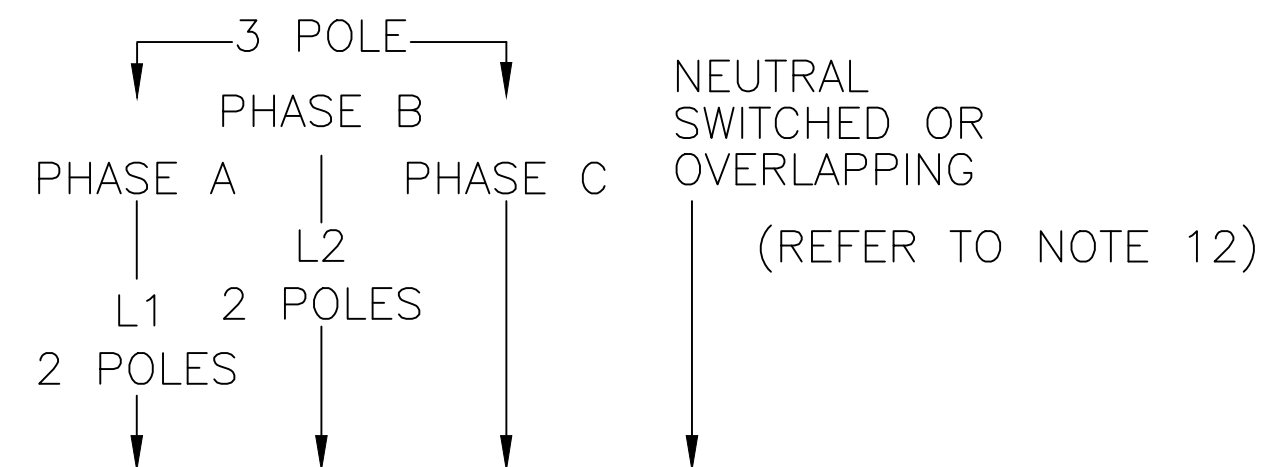

(FRONT VIEW)

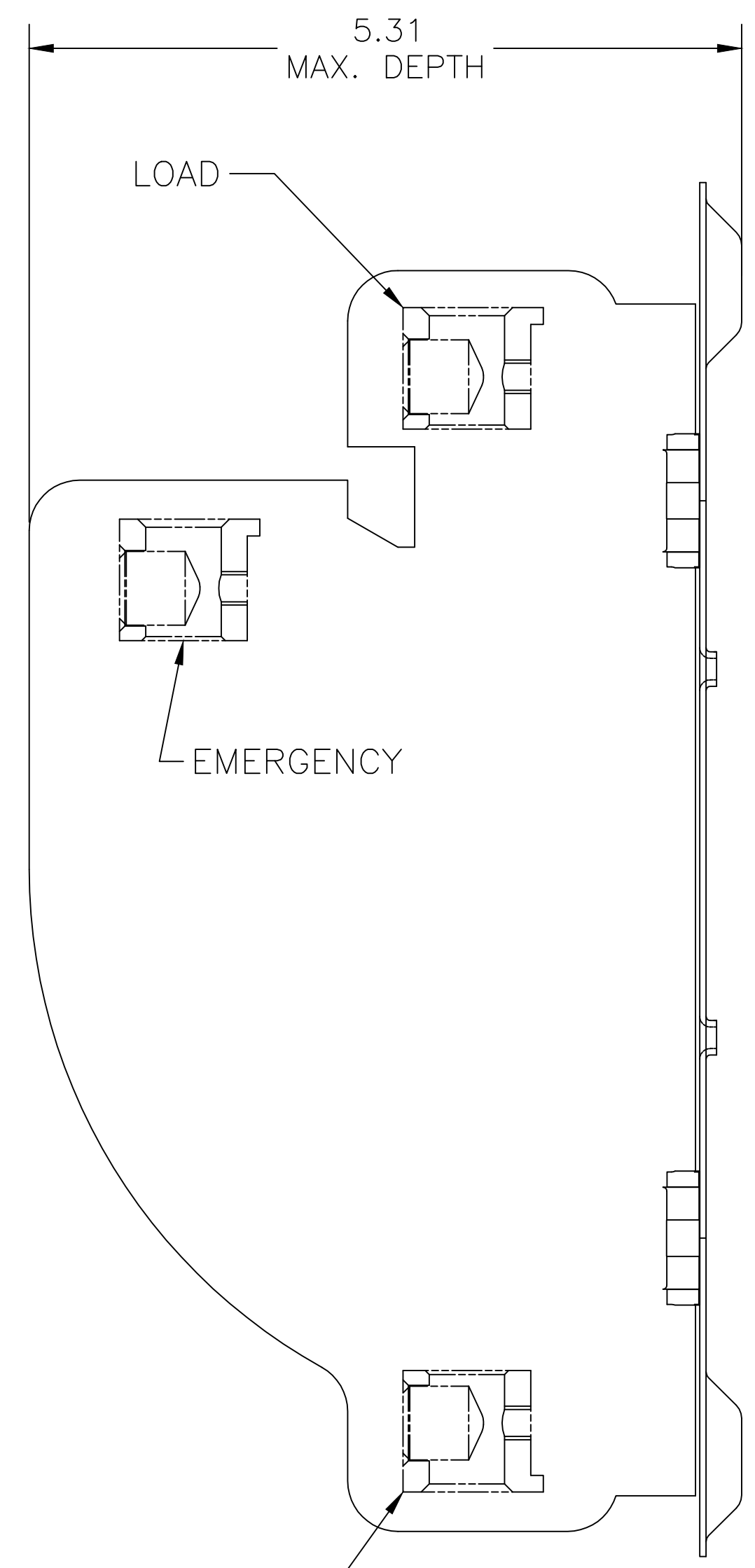

(SIDE VIEW)

Ø0.312 MOUNTING HOLE DIA.

B	251362	TR	BK	10/22/14
SEE ECN				
A	249616	AE	BK	07/20/14
SEE ECN				
-	245200	BWM	SDH	11/1/13
ISSUED				

PROJECT NAME:		REV. TO SHEET	ECN NO.	BY	APP.	DATE
COMPOSITE OUTLINE						
300 SERIES, D3ATS/D3NTS RATED 30-230 AMPERES						
OPEN TYPE						
BY	DATE	MANUFACTURING TOLERANCES TO BE IN ACCORDANCE WITH ASCO PROCEDURE MP-1-003. FOR PLASTIC PARTS SEE MP-1-055.		ASSEM. REF. NO.	COMPUTER GENERATED DRAWING	
CHECKED		PROPERTY OF ASCO POWER TECHNOLOGIES. USE PERMITTED FOR OUR WORK ONLY. ALL RIGHTS OF DESIGN OR INVENTION ARE RESERVED.		SCALE	NONE	SIZE DS
PROJECT APPROVAL				DWG. NO.	987723-002	
FINAL APPROVAL	SDH 11/1/13	ASCO® ASCO POWER TECHNOLOGIES, L.P. FLORHAM PARK, NEW JERSEY 07932 U.S.A.		DRAWING REV.	ECN NO. 251362	SHEET 2 OF 3

OUTLINE FOR ASCO® 300 SERIES TRANSFER SWITCHES (D3ATS,D3NTS) 30-230 AMPERES OPEN TYPE

CONTROL PANEL & CONTROLS MOUNTING

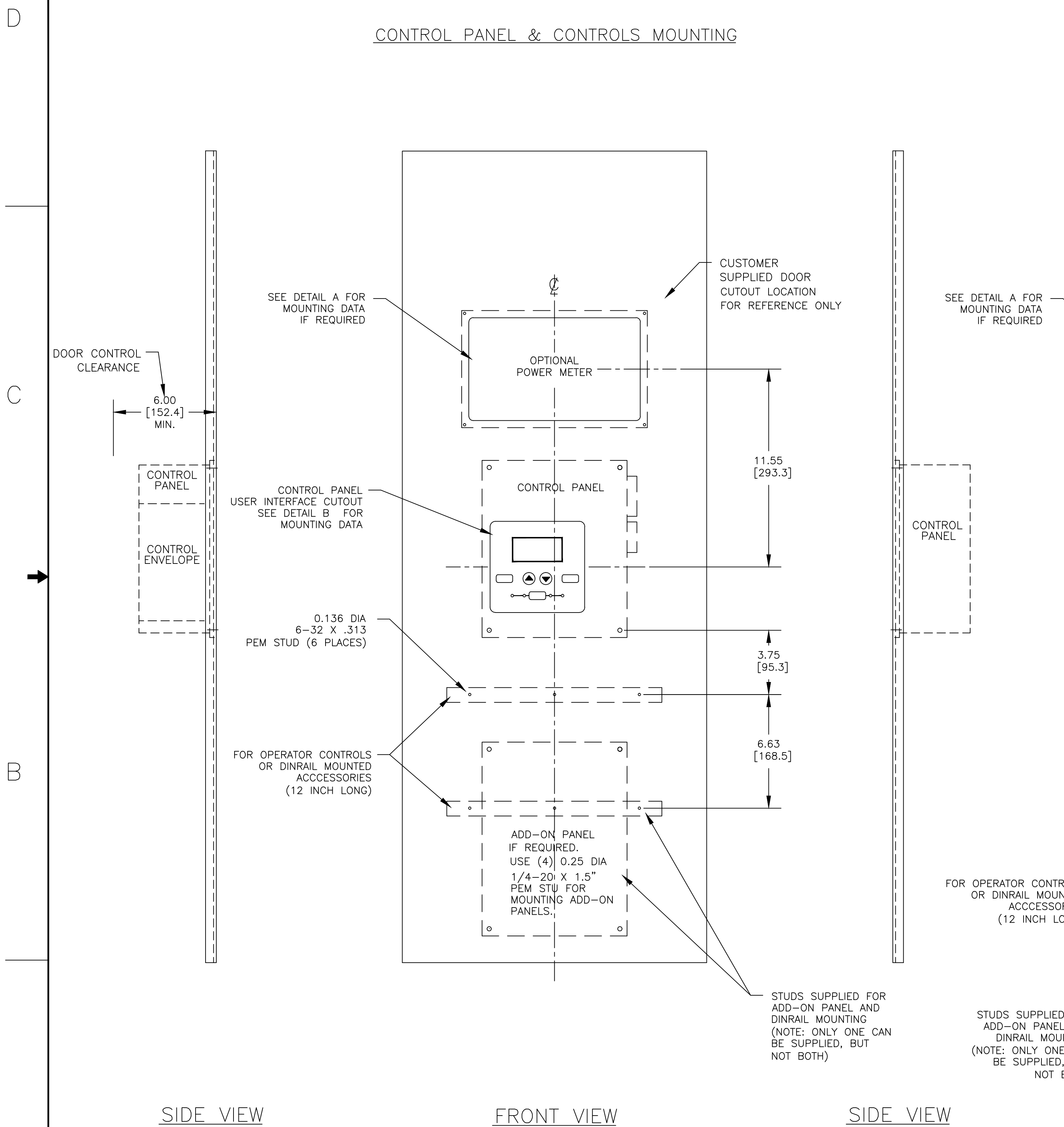

DEVICES ON MOUNTING RAILS (FOR SHIPPING ONLY)

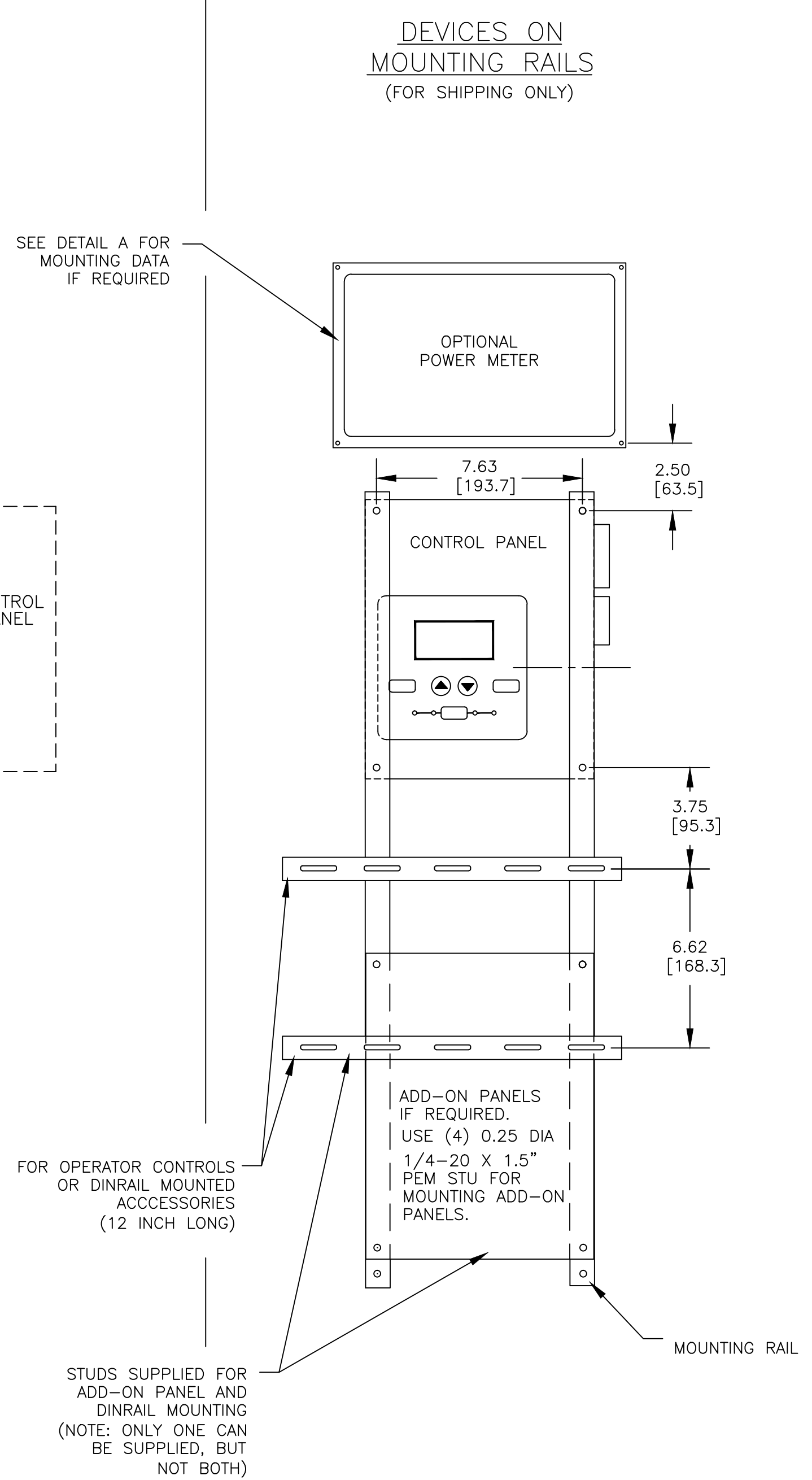

CONTROL PANEL & CONTROLS MOUNTING DATA

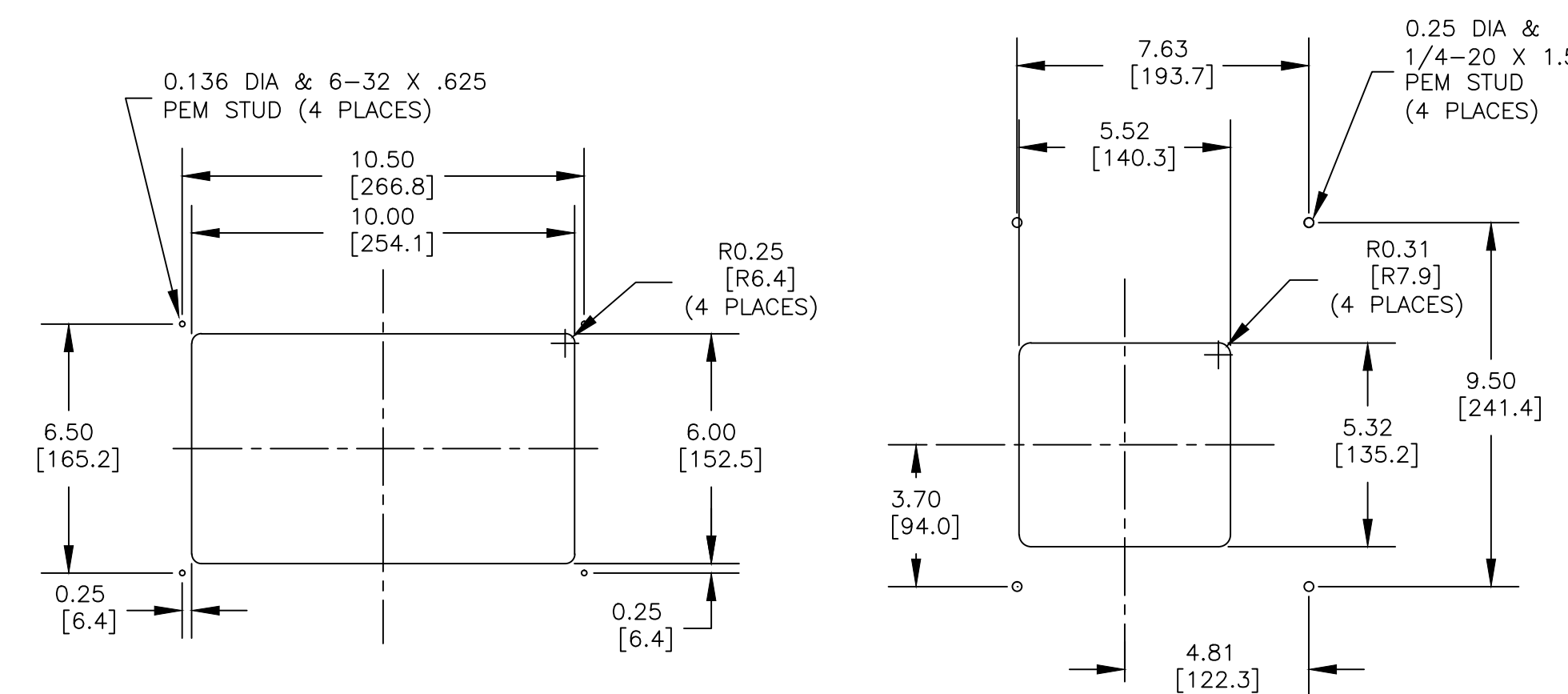

DETAIL A -1 (FOR TYPE 1)

DETAIL B -1 (FOR TYPE 1)

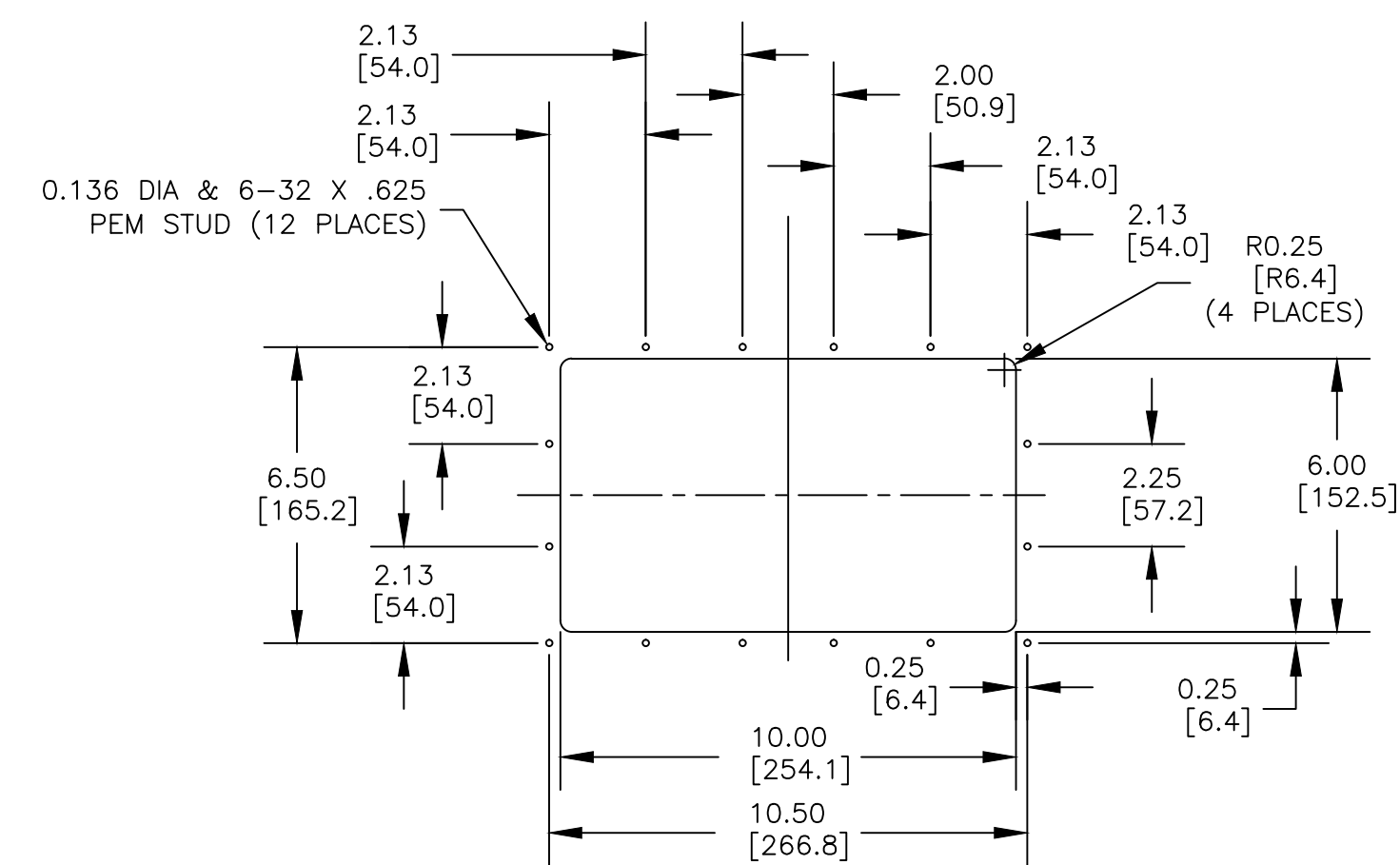

DETAIL A -2 (FOR TYPE 3R, 12 & 4)

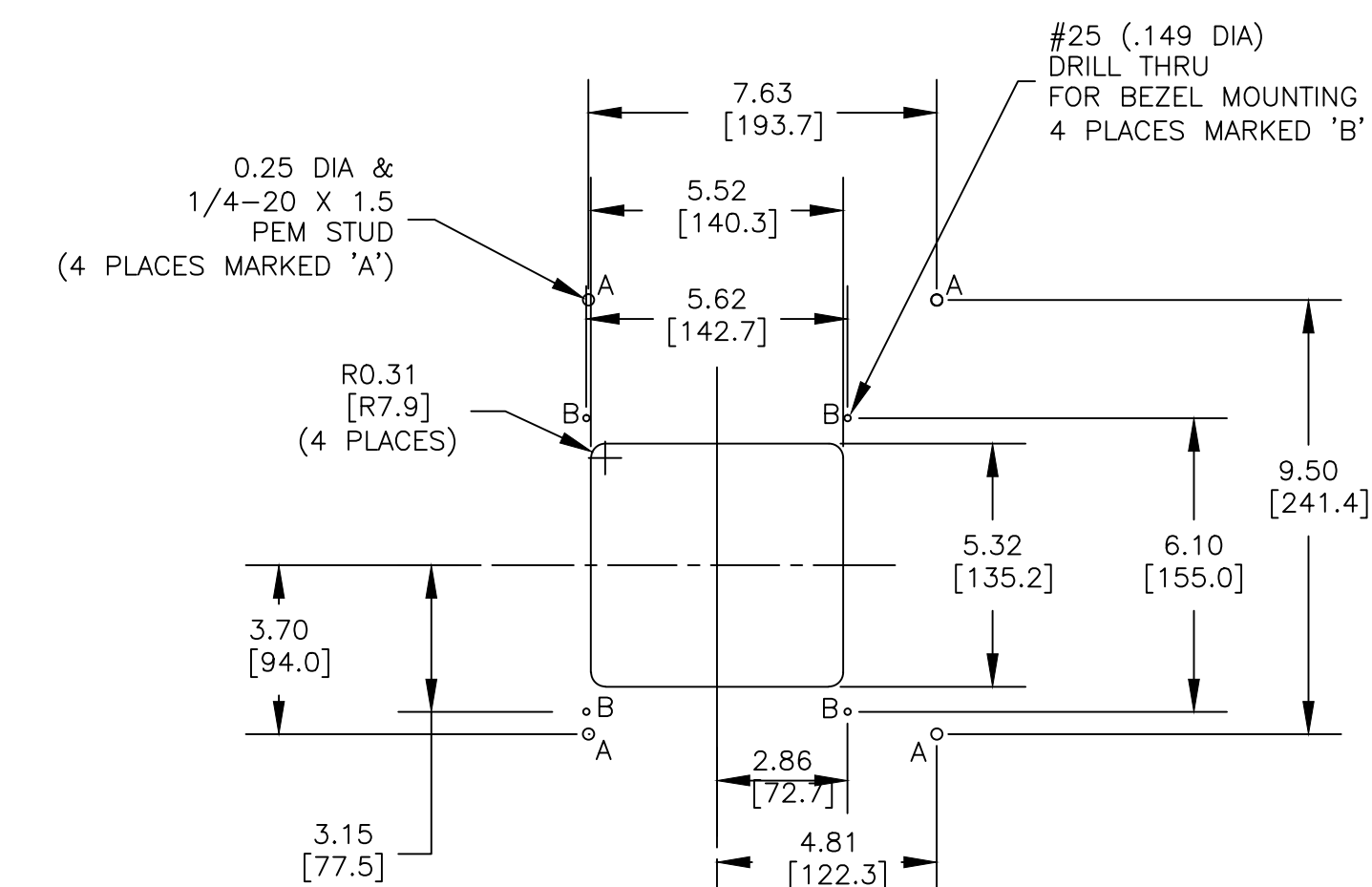

DETAIL B -2 (FOR TYPE 3R, 12 & 4)

PROJECT NAME:		COMPOSITE OUTLINE		300 SERIES, D3ATS/D3NTS RATED 30-230 AMPS		OPEN TYPE	
BY	DATE	MANUFACTURING TOLERANCES TO BE IN ACCORDANCE WITH ASCO PROCEDURE MP-1-003. FOR PLASTIC PARTS SEE MP-1-005		ASSEM. REF. NO.	SCALE		SIZE
DRAWN BY	BWM	11/1/13				None	DS
CHECKED			PROPERTY OF ASCO POWER TECHNOLOGIES. USE PERMITTED FOR OUR WORK ONLY. ALL RIGHTS OF DESIGN OR INVENTION ARE RESERVED.		DWG. NO.		
PROJECT APPROVAL					987723-002		
FINAL APPROVAL	SDH	11/1/13	ASCO POWER TECHNOLOGIES, L.P. FLOHAM PARK, NEW JERSEY 07932 U.S.A.		DRAWING BY	ECN NO.	SHEET
					B	251362	3 OF 3

B	251362	BK	TR	10/23/14
A	249616	AE	BK	07/20/14
-	245200	BWM	SDH	11/1/13

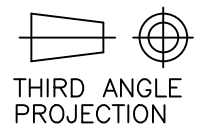

ASCO