

OUTLINE FOR ASCO® 300 SERIES 260-400 AMPERE "J" FRAME (J3ATS,J3NTS) FRONT CONNECTED TRANSFER SWITCHES OPEN TYPE

FRONT VIEW

SIDE VIEW

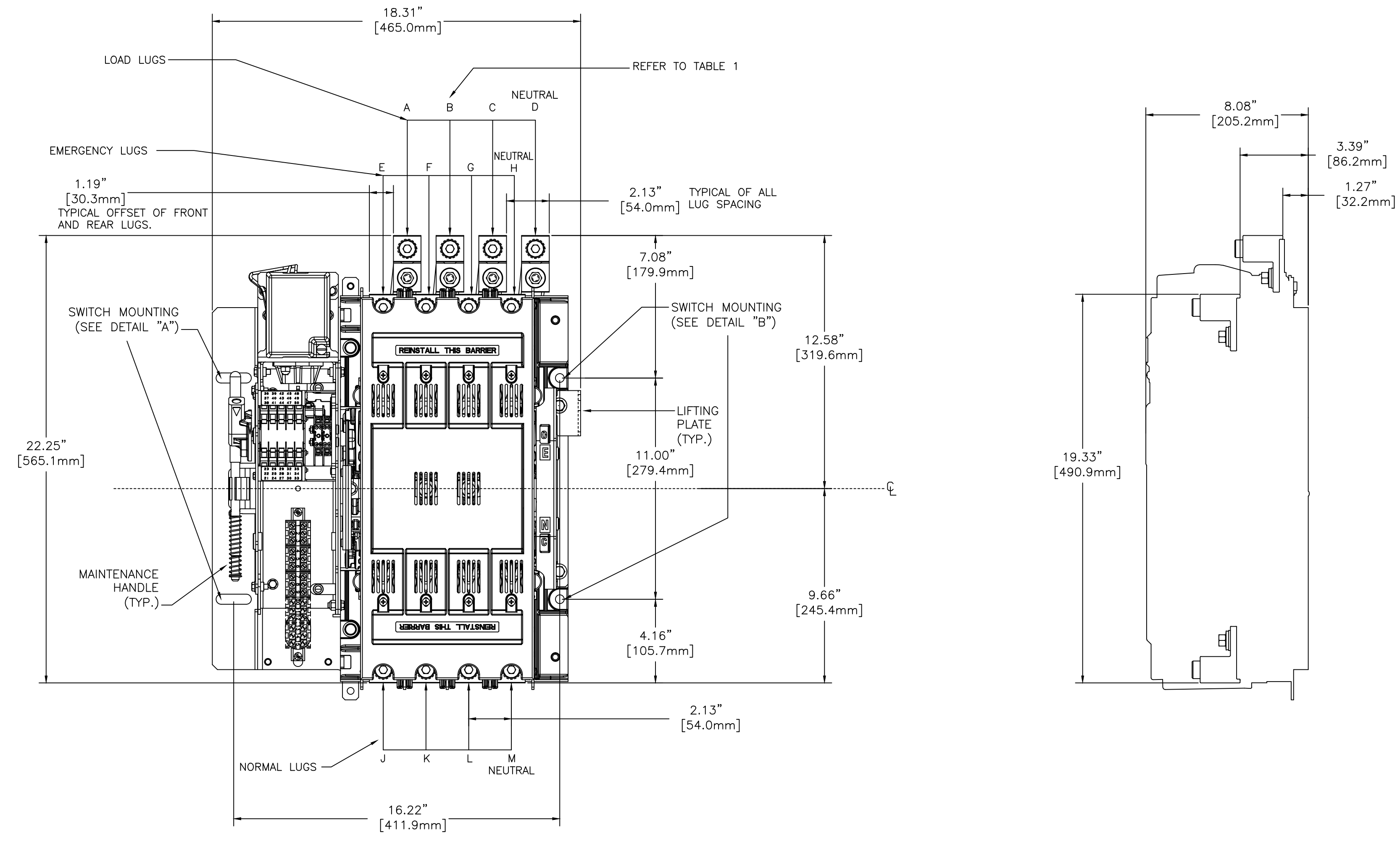

260-400 AMP ATS/NTS

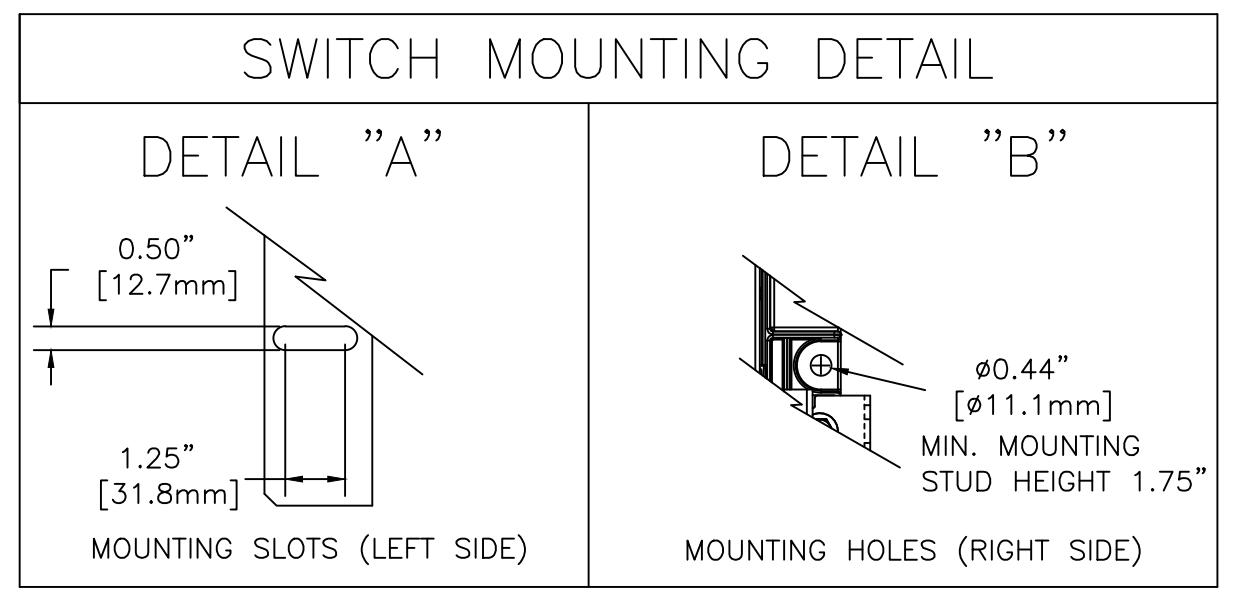

TABLE 1: POLE LOCATIONS

POLES	A	B	C	D	E	F	G	H	J	K	L	M
2	LL1		LL2		EL1		EL2		NL1		NL2	
B2	LL1	LL0	LL2		EL1	ELO	EL2		NL1	NLO	NL2	
3	LA	LB	LC		EA	EB	EC		NA	NB	NC	
B3	LA	LB	LC	LN	EA	EB	EC	EN	NA	NB	NC	NN
4	LA	LB	LC	LN	EA	EB	EC	EN	NA	NB	NC	NN

150-400A UNITS APPROX. SHIPPING WEIGHT, LBS (KG)		
SWITCH TYPE	POLES	WEIGHTS LB (KG)
ATS / NTS	2	68 (31)
ATS / NTS	3 OR B2	74 (31)
ATS / NTS	4 OR B3	80 (36)

PROJECT NAME: COMPOSITE OUTLINE
 300 SERIES ATS/NTS "J" FRAME
 260-400A OPEN TYPE

REV. TO SHEET	ECN NO.	BY	APP.	DATE
A	265710	TR	BK	03/22/17
	264826	JPB	JPB	12/23/16

SCALE: NONE SIZE: DS
 DWG. NO. 1001393-012
 SHEET 1 OF 3

ASCO® ASCO POWER TECHNOLOGIES, L.P.
 FLORHAM PARK, NEW JERSEY 07932 U.S.A.

OUTLINE FOR ASCO® 300 SERIES 260-400 AMPERE "J" FRAME (J3ATS,J3NTS) FRONT CONNECTED TRANSFER SWITCHES OPEN TYPE

MOUNTING OF FIELD TERMINAL BLOCK ASSEMBLY (TB) AND SOLID NEUTRAL TERMINAL ASSEMBLY (NTA)

(REFER TO NOTE 10)

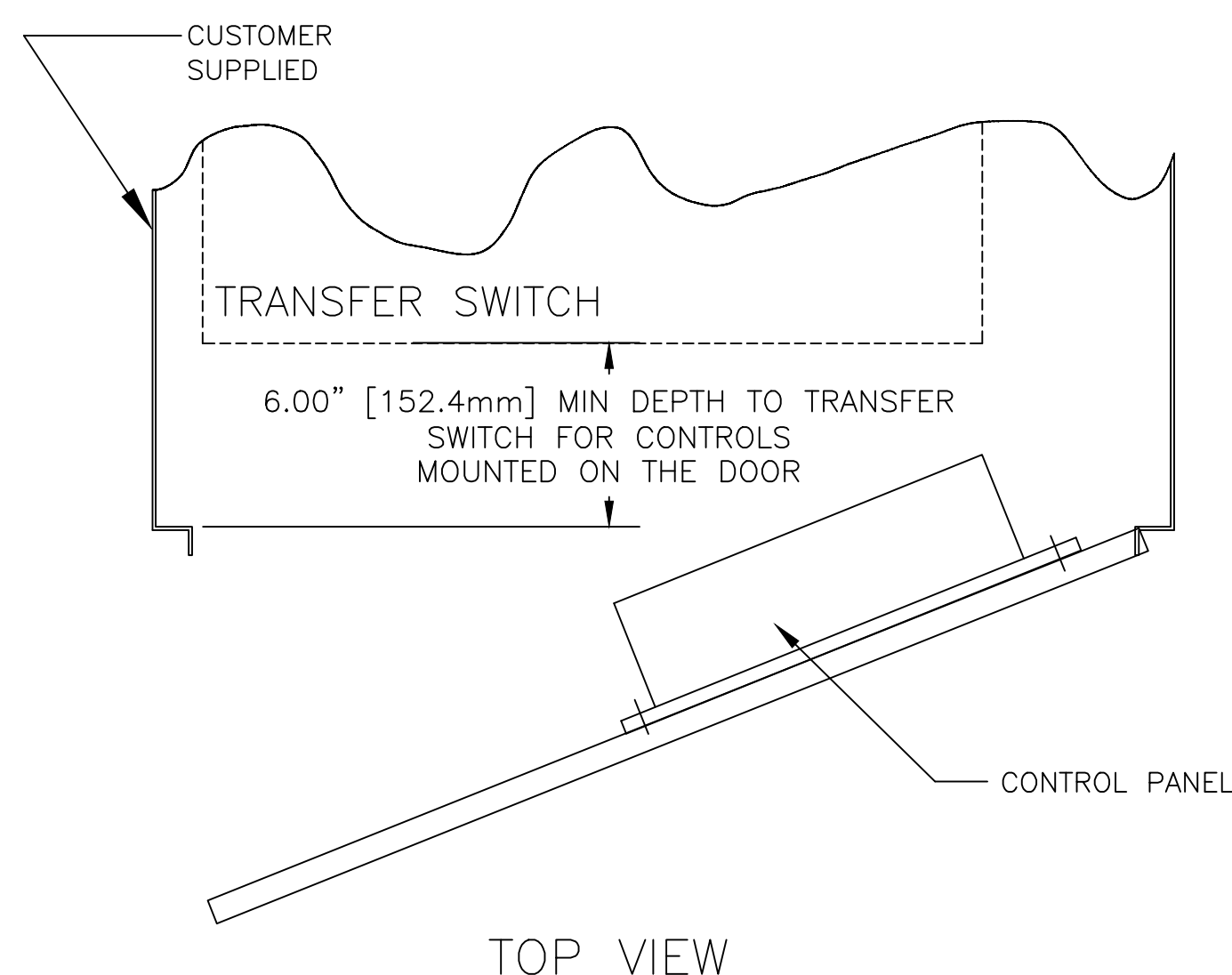

TOP VIEW

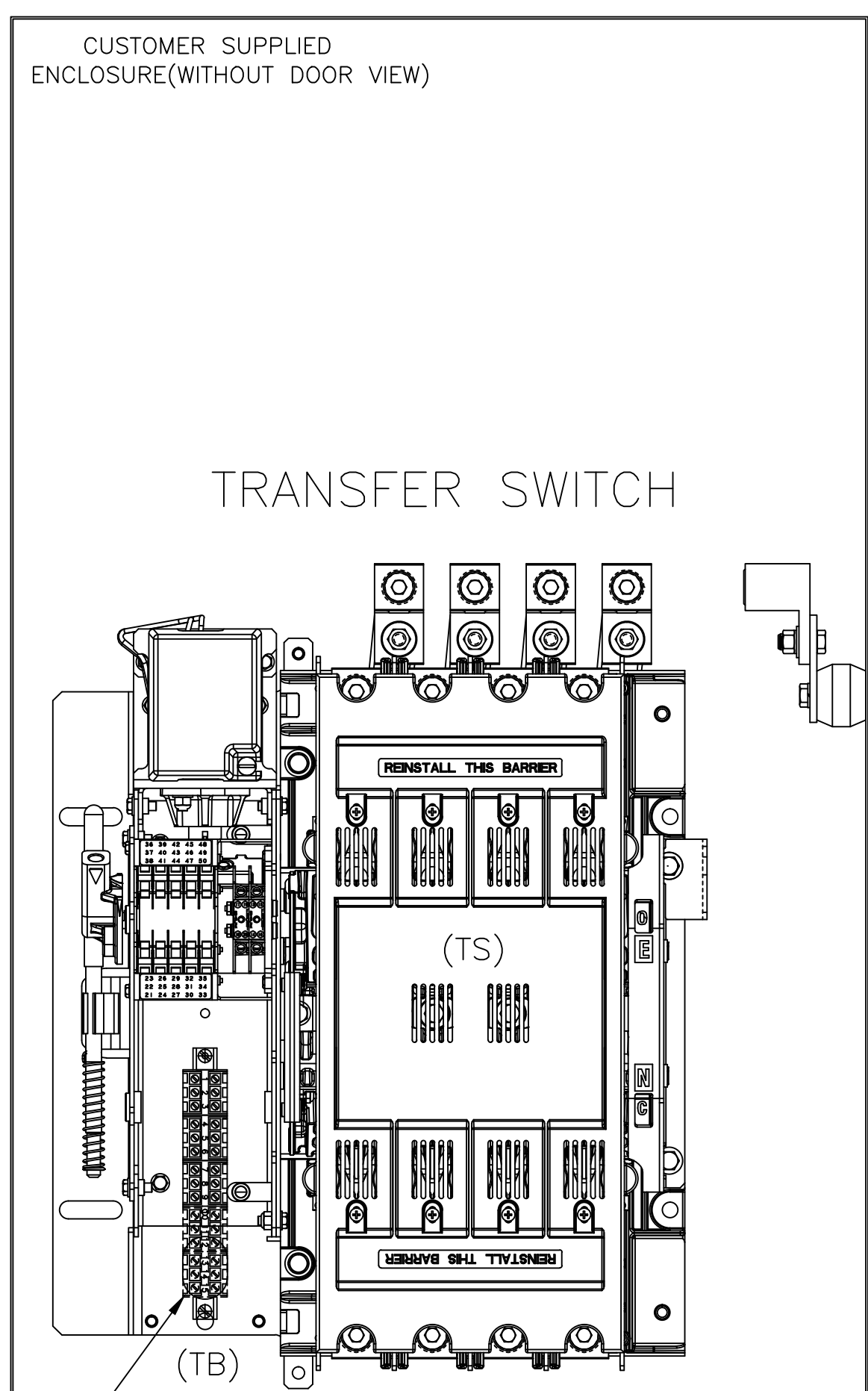

FRONT VIEW

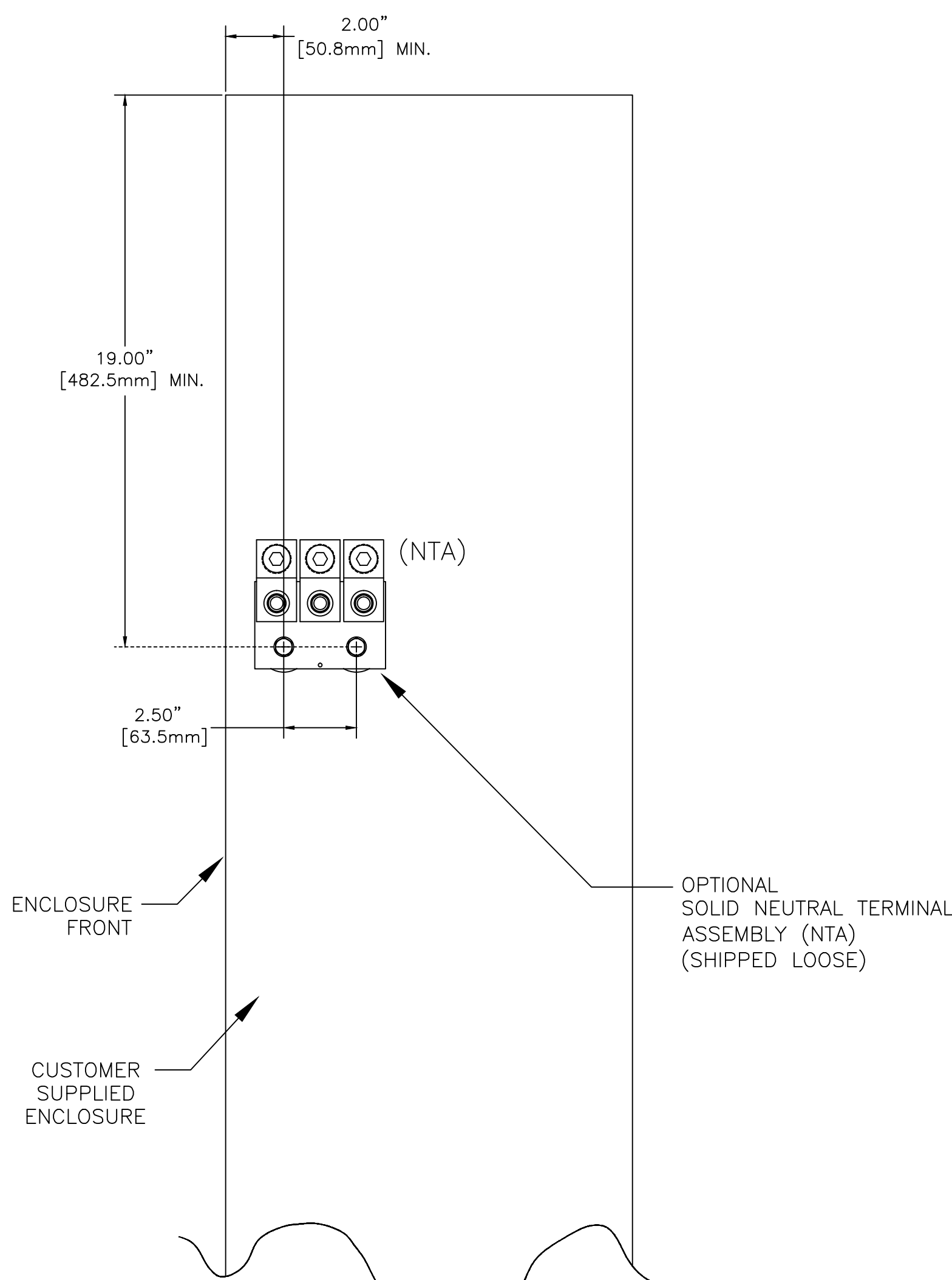

RIGHT SIDE VIEW

GENERAL NOTES

1. THE STANDARD SWITCH CONFIGURATION IS FOR TOP (LOAD & EMERGENCY) AND BOTTOM (NORMAL).
2. NEUTRAL CONFIGURATIONS:
AN OPTIONAL FULL RATED NEUTRAL CONFIGURATION FOR EACH SOURCE AND THE LOAD MAY BE PROVIDED. WHEN EQUIPPED IT IS IN ONE OF THE FOLLOWING FORMATS AS SPECIFIED BY THE CATALOG NUMBER NO. NEUTRAL TYPE:
(A) SOLID NEUTRAL TERMINAL ASSEMBLY (NTA)
(B) SWITCHED NEUTRAL POLE
3. THE STANDARD MECHANICAL (SCREW TYPE) AL/CU TERMINAL LUGS ARE SHOWN FOR REFERENCE.
4. WHEN INSTALLING CONDUCTORS, CONNECT TO SIMILARLY MARKED PHASES OF NORMAL, EMERGENCY & LOAD.
5. ALL INTERNAL CONNECTIONS ARE MADE AT FACTORY.
6. MAINTAIN ELECTRICAL CLEARANCE OF 1.00" [25.4mm] BETWEEN LIVE METAL PARTS AND GROUNDED METAL.
7. WHEN MOUNTING THE TRANSFER SWITCH IN THE ENCLOSURE, THE CONTROL PANEL(S) AND OPERATOR CONTROLS SHOULD BE MOUNTED ON THE INSIDE, REAR SURFACE OF THE DOOR. 6.00" [152.4mm] MIN. DEPTH TO TRANSFER SWITCH FOR CONTROLS IS REQUIRED.
8. THE CONTROL PANEL(S) IS CONNECTED TO THE TRANSFER SWITCH BY A HARNESS WITH A QUICK DISCONNECT PLUG(S). THE HARNESS EXITS THE TRANSFER SWITCH ON THE RIGHT SIDE. CONSULT FACTORY FOR EXTENSION HARNESSES.
9. FOR TYPE 1 ENCLOSURE SEE DETAIL A -1 AND DETAIL B -1 FOR CUTOUT DATA. FOR TYPE 3R, 4, & 12 ENCLOSURE SEE DETAIL A -2 & DETAIL B -2 FOR CUTOUT DATA. GASKETS AND BEZELS ARE PROVIDED FOR TYPE 3R, 4, & 12 ENCLOSURE.
10. CUSTOMER TERMINAL BLOCKS:
FOR ATS AND NTS THE TB WILL BE MOUNTED ON THE TRANSFER SWITCH FRAME AS INDICATED ON THIS PAGE.

SIZE	CABLE ACCOMMODATIONS (PER PHASE & NEUTRAL)
260-400	SCREW TYPE (STANDARD)- (2) 1/0 - 250 MCM AL/CU OR (1) #4 - 600 MCM AL/CU

CABLING NOTES

1. ALL SIZES SUPPLIED STANDARD WITH MECHANICAL (SCREW TYPE) LUGS. (SEE AMP SIZE BELOW)
A. LUG MATERIAL: ALUMINUM ALLOY 6061-T6 WITH ELECTRO TIN PLATED FINISH.
B. SCREW MATERIAL: ALUMINUM ALLOY 6262-T9 WITH ELECTRO TIN PLATED FINISH.
C. UL LISTED, CSA CERTIFIED.
D. LUG SCREW TIGHTENING TORQUE PER UL 486B: 19 FT-LBS.

NOTES 260-400 AMP SWITCHES

1. SUPPLIED WITH STANDARD MECHANICAL (SCREW TYPE) LUGS ON THE NORMAL, EMERGENCY & LOAD BUS STABS. ONE (1) LUG PER PHASE AND SWITCHING NEUTRAL WHEN SUPPLIED, EACH SUITABLE FOR CONNECTION OF TWO (2) 1/0 -250MCM CU/AL CABLES OR ONE (1) #4 -600MCM CU/AL CABLE.
2. OPTIONAL SOLID NEUTRAL TERMINAL ASSEMBLY. (NTA)
EACH TERMINAL SUITABLE FOR CONNECTION OF TWO (2) 1/0 -250MCM CU/AL CABLES OR ONE (1) #4 -600MCM CU/AL CABLE.

MINIMUM REQUIRED ENCLOSURE SIZE INCH (mm)

SWITCH RATING (AMPS)	HEIGHT	WIDTH	DEPTH
260-400	56.00" (1422)	24.00" (610mm)	14.00" (356mm)

A	265710	TR	BK	03/22/17
	SEE ECN			
	264826	JPB	JPB	12/23/16
	ISSUE			

PROJECT NAME:		REV. TO SHEET	ECN NO.	BY	APP.	DATE
COMPOSITE OUTLINE						
300 SERIES ATS/NTS "J" FRAME						
260-400A OPEN TYPE						
BY	DATE	MANUFACTURING TOLERANCES TO BE IN ACCORDANCE WITH ASCO PROCEDURE MP-1-003. FOR PLASTIC PARTS SEE MP-1-005		ASSEM. REF. NO.	COMPUTER GENERATED DRAWING	
DRAWN BY	JPB	12/23/16			SCALE	SIZE DS
CHECKED			PROPERTY OF ASCO POWER TECHNOLOGIES. USE PERMITTED FOR OUR WORK ONLY. ALL RIGHTS OF DESIGN OR INVENTION ARE RESERVED.		DWG. NO.	
PROJECT APPROVAL					1001393-012	
FINAL APPROVAL	JPB	12/23/16			ASCOS	ASCOS
					ASCOS	ASCOS
					ASCOS	ASCOS

ASCOS ASCO POWER TECHNOLOGIES, L.P. FLORHAM PARK, NEW JERSEY 07932 U.S.A.

DRAWING A REV. ECH NO. 265710 SHEET 2 OF 3

OUTLINE FOR ASCO® 300 SERIES 260-400 AMPERE "J" FRAME (J3ATS, J3NTS) FRONT CONNECTED TRANSFER SWITCHES OPEN TYPE

CONTROL PANEL & CONTROLS MOUNTING DATA

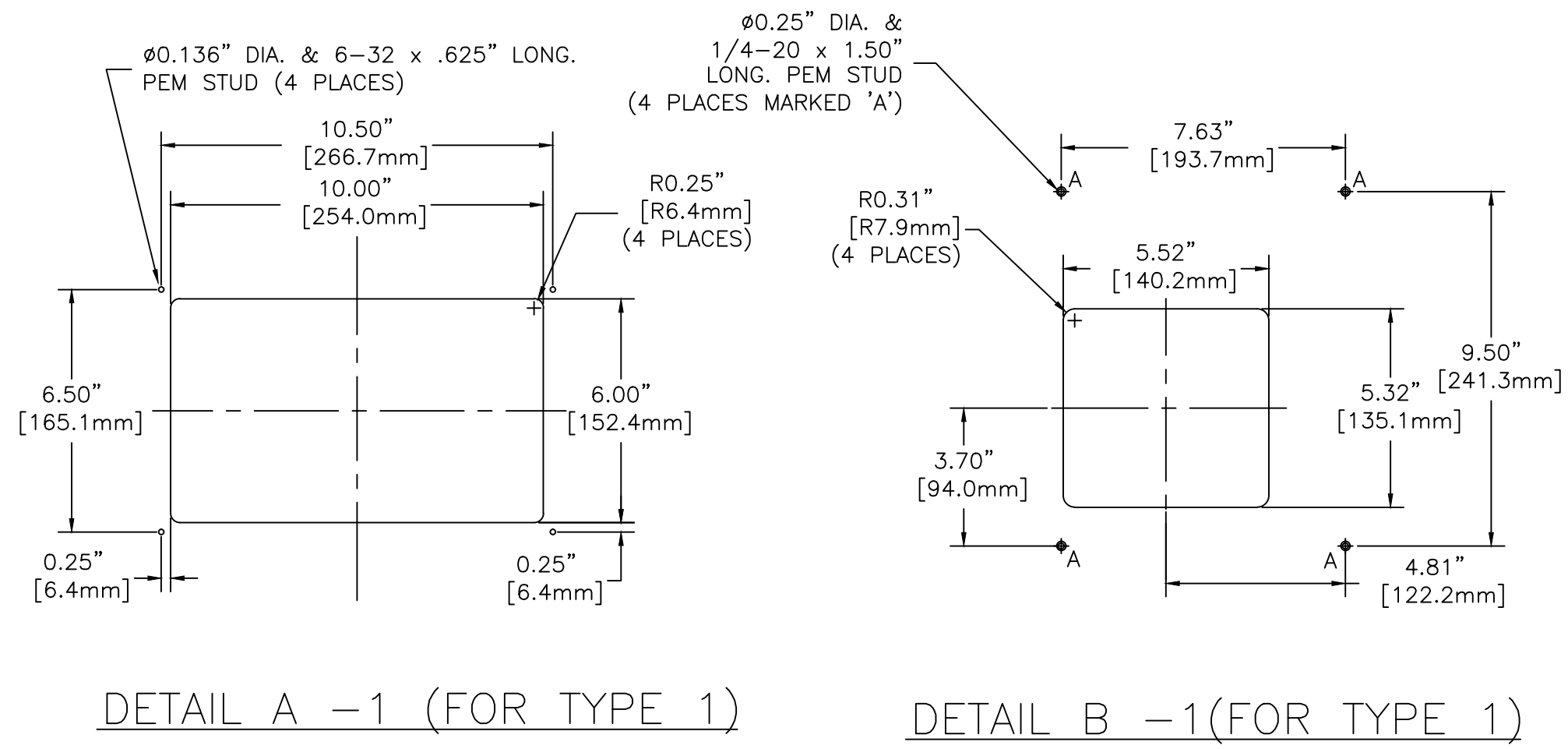

CONTROL PANEL & CONTROLS MOUNTING

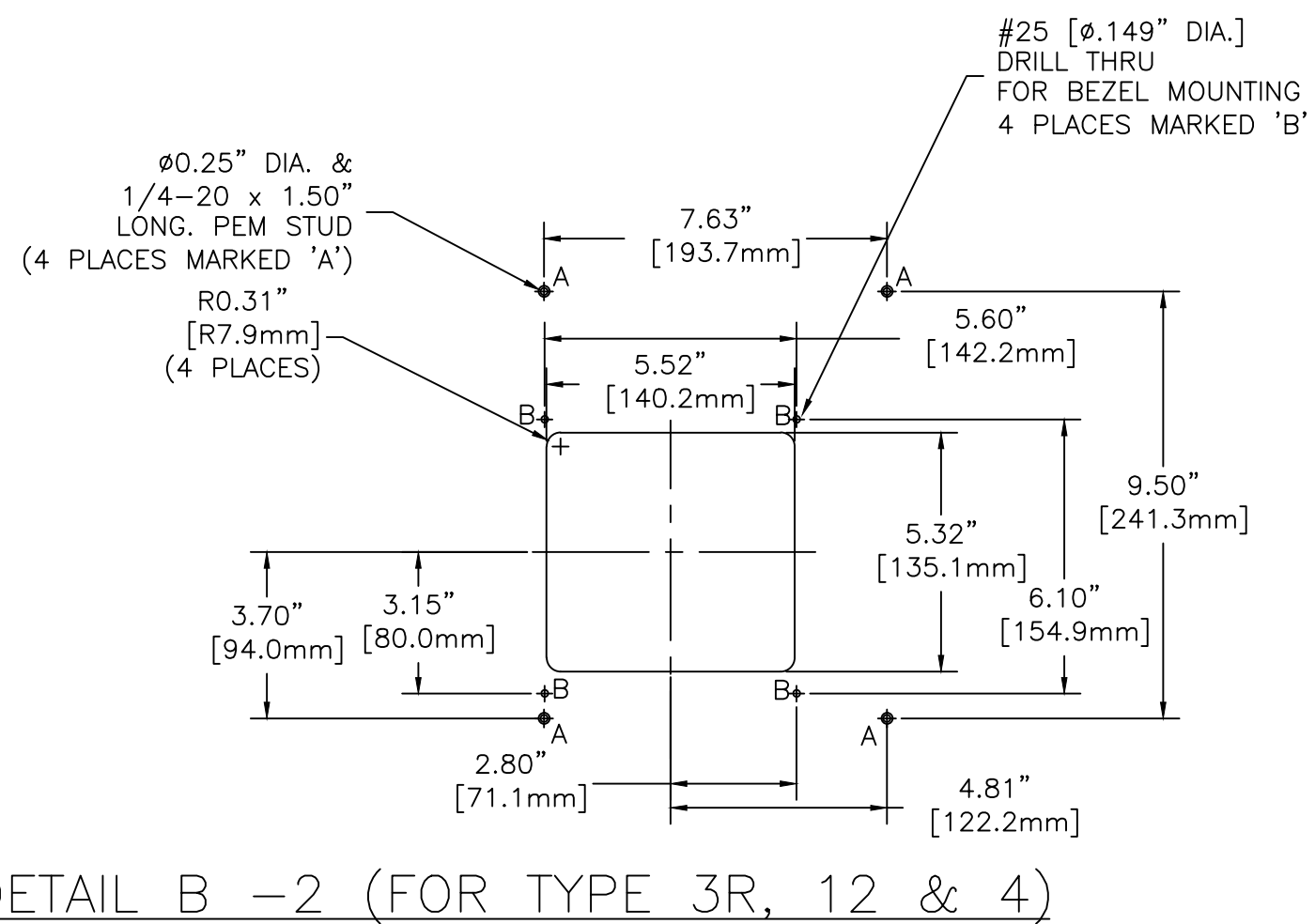
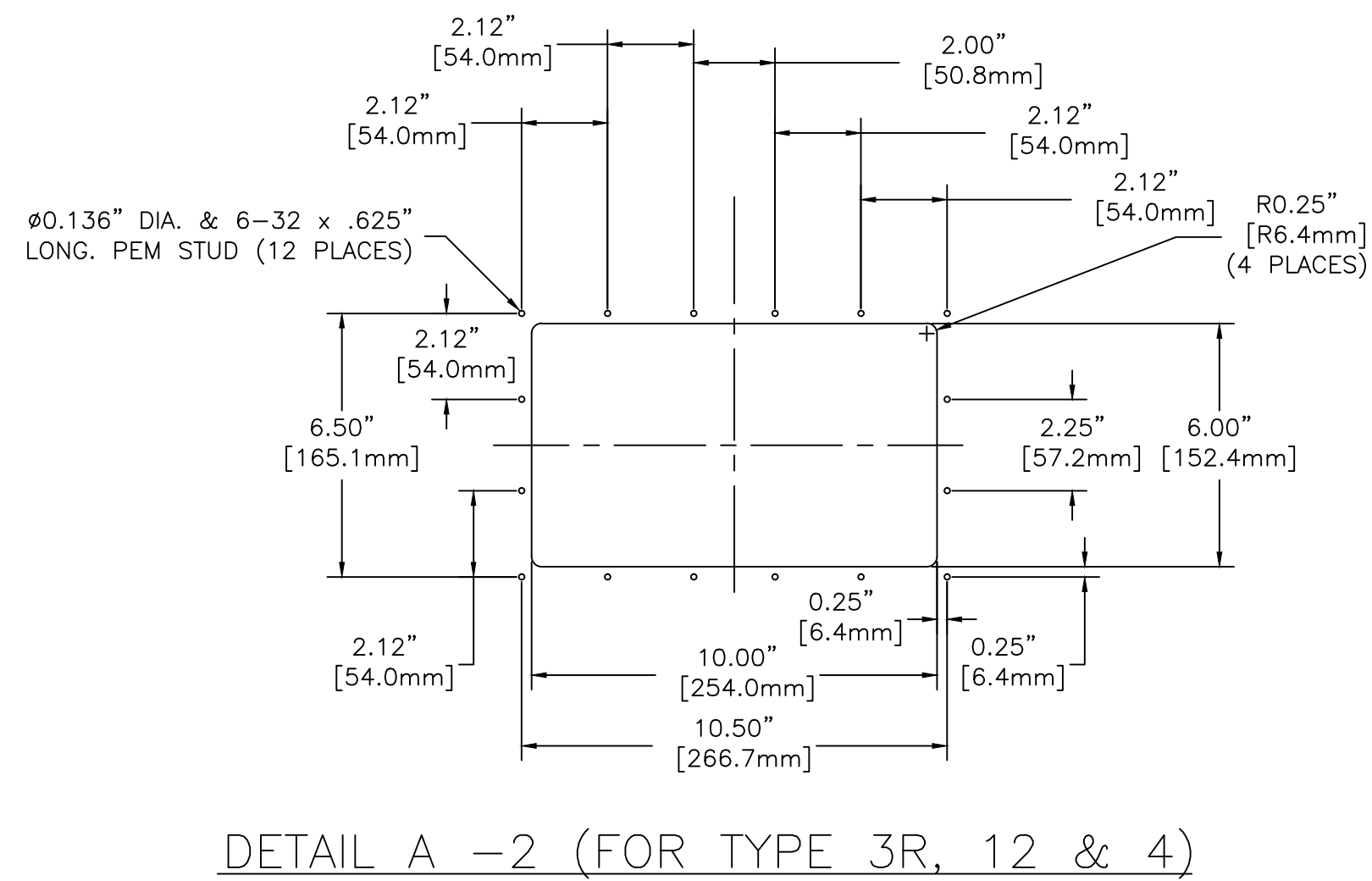
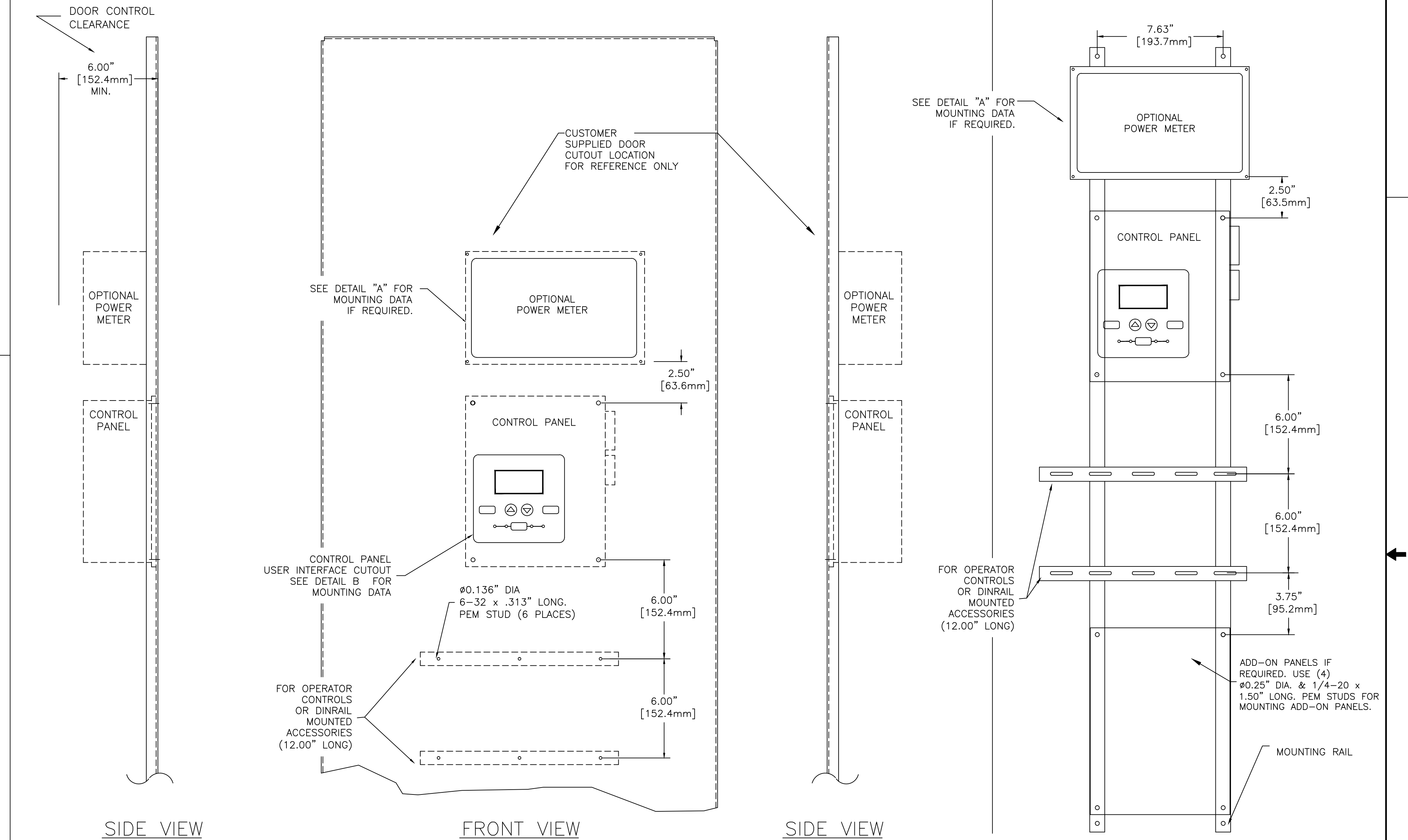

PROJECT NAME:		REV. TO SHEET		ECN NO.		BY		APP.		DATE	
COMPOSITE OUTLINE		A		265710		TR		BK		03/22/17	
300 SERIES ATS/NTS "J" FRAME		SEE ECN		264826		JPB		JPB		12/23/16	
260-400A OPEN TYPE		ISSUE									
DRAWN BY		DATE		MANUFACTURING TOLERANCES TO BE IN ACCORDANCE WITH ASCO PROCEDURE MP-1-003. FOR PLASTIC PARTS SEE MP-1-055		ASSEM. REF. NO.		SCALE		SIZE	
CHECKED				PROPERTY OF ASCO POWER TECHNOLOGIES. USE PERMITTED FOR OUR WORK ONLY. ALL RIGHTS OF DESIGN OR INVENTION ARE RESERVED.				NONE		DS	
PROJECT APPROVAL				DRAWING NO.				1001393-012		SHEET	
FINAL APPROVAL		JPB 12/23/16		ASCO® ASCO POWER TECHNOLOGIES, L.P. FLOHAM PARK, NEW JERSEY 07932 U.S.A.		REV.		A		3 OF 3	