

8 7 6 5 4 3 2 1
OUTLINE FOR ASCO® 300 SERIES 2600-3000 AMPERE "G" FRAME (G3ATS,G3NTS,G3ADTS,G3NDTS) REAR CONNECTED TRANSFER SWITCHES TYPE 1 ENCLOSURE

GENERAL NOTES

- TYPE 1 ENCLOSURE. FREE STANDING. FLOOR MOUNTED. CODE GAUGE FORMED FRAME CONSTRUCTION.
- NEC STANDARD GAUGE PAN TYPE DOOR WITH LOCKABLE HANDLE.
- FINISH: ANSI 61 GRAY, POLYESTER POWDER STANDARD. OTHER ANSI COLORS AVAILABLE CONSULT FACTORY. UL RECOGNIZED.
- CONSTRUCTION IS IN ACCORDANCE WITH APPLICABLE REQUIREMENTS OF UL 1008.
- RECOMMENDED CLEARANCES:
FRONT: 36 INCHES
- A 20% RATED GROUND BUS IS PROVIDED.
- UNIT IS DESIGNED FOR COMBINATION TOP AND BOTTOM CABLE ENTRY.
- NEUTRAL CONFIGURATIONS:
AN OPTIONAL FULL RATED NEUTRAL CONFIGURATION FOR EACH SOURCE AND THE LOAD MAY BE PROVIDED. WHEN EQUIPPED IT IS IN ONE OF THE FOLLOWING FORMATS AS SPECIFIED BY THE CATALOG NUMBER NO. NEUTRAL TYPE:
(A) SOLID (COPPER BUS) NEUTRAL.
(B) SWITCHED NEUTRAL POLE.
-  CENTER OF GRAVITY.
- NO KNOCKOUTS ARE PROVIDED.

CABLING NOTES

- ALL SIZES SUPPLIED STANDARD WITH MECHANICAL (SCREW TYPE) LUGS. (SEE AMP SIZE BELOW)
A. LUG MATERIAL: ALUMINUM ALLOY 6061-T6 WITH ELECTRO TIN PLATED FINISH.
B. SCREW MATERIAL: ALUMINUM ALLOY 6262-T9 WITH ELECTRO TIN PLATED FINISH.
C. UL LISTED, CSA CERTIFIED.
D. LUG SCREW TIGHTENING TORQUE PER UL 486B: 19 FT-LBS.
E. SUITABLE WIRE BENDING SPACE IS PROVIDED. (SEE AMP SIZE BELOW)
- GROUND LUGS ARE PROVIDED STANDARD AS FOLLOWS. (SEE AMP SIZE BELOW)

NOTES 2600-3000 AMPS

- SUPPLIED WITH STANDARD MECHANICAL (SCREW TYPE) LUGS ON THE NORMAL, EMERGENCY & LOAD BUS STABS. ONE (1) LUG PER PHASE AND NEUTRAL EACH SUITABLE FOR CONNECTION OF TWELVE (12) 1/0 -750MCM CU/AL CABLE (SEE NOTE "E" BELOW).
E. SUITABLE WIRE BENDING SPACE IS PROVIDED FOR UP TO TWELVE (12) 750MCM CABLES PER TERMINAL PER NEC.
- GROUND LUGS ARE PROVIDED STANDARD AS FOLLOWS;
(36) 1/0 - 750MCM CU/AL CABLE

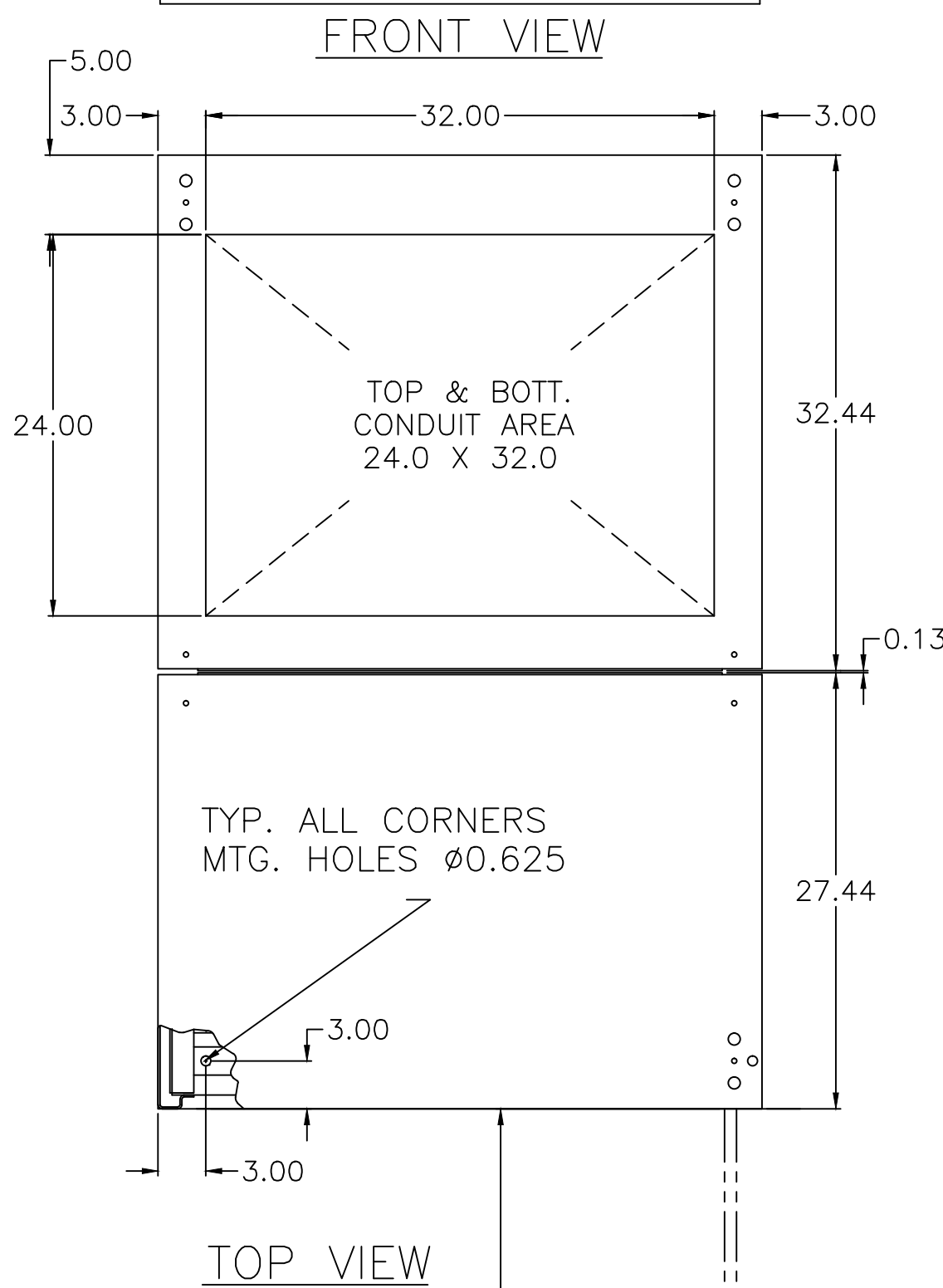
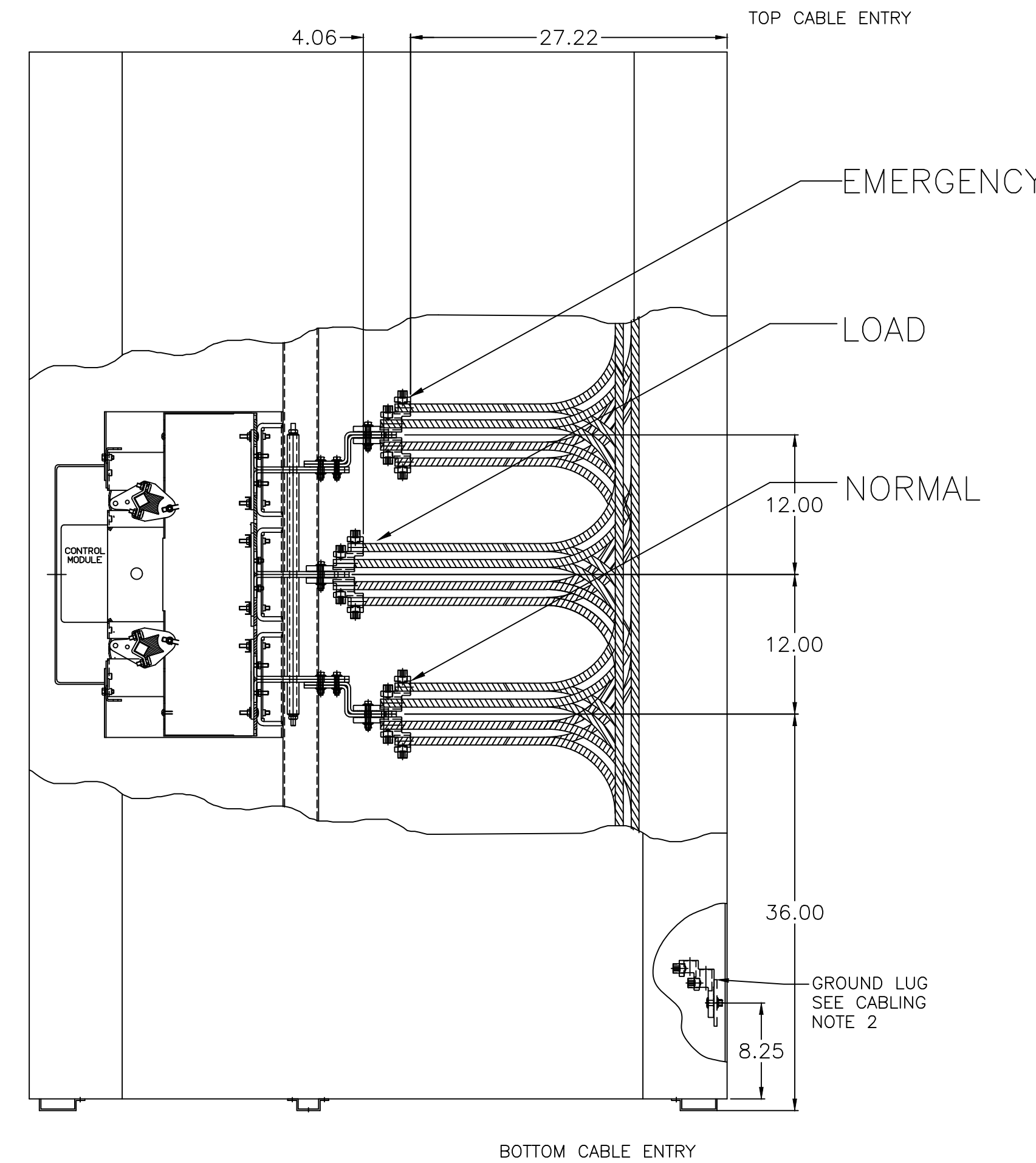
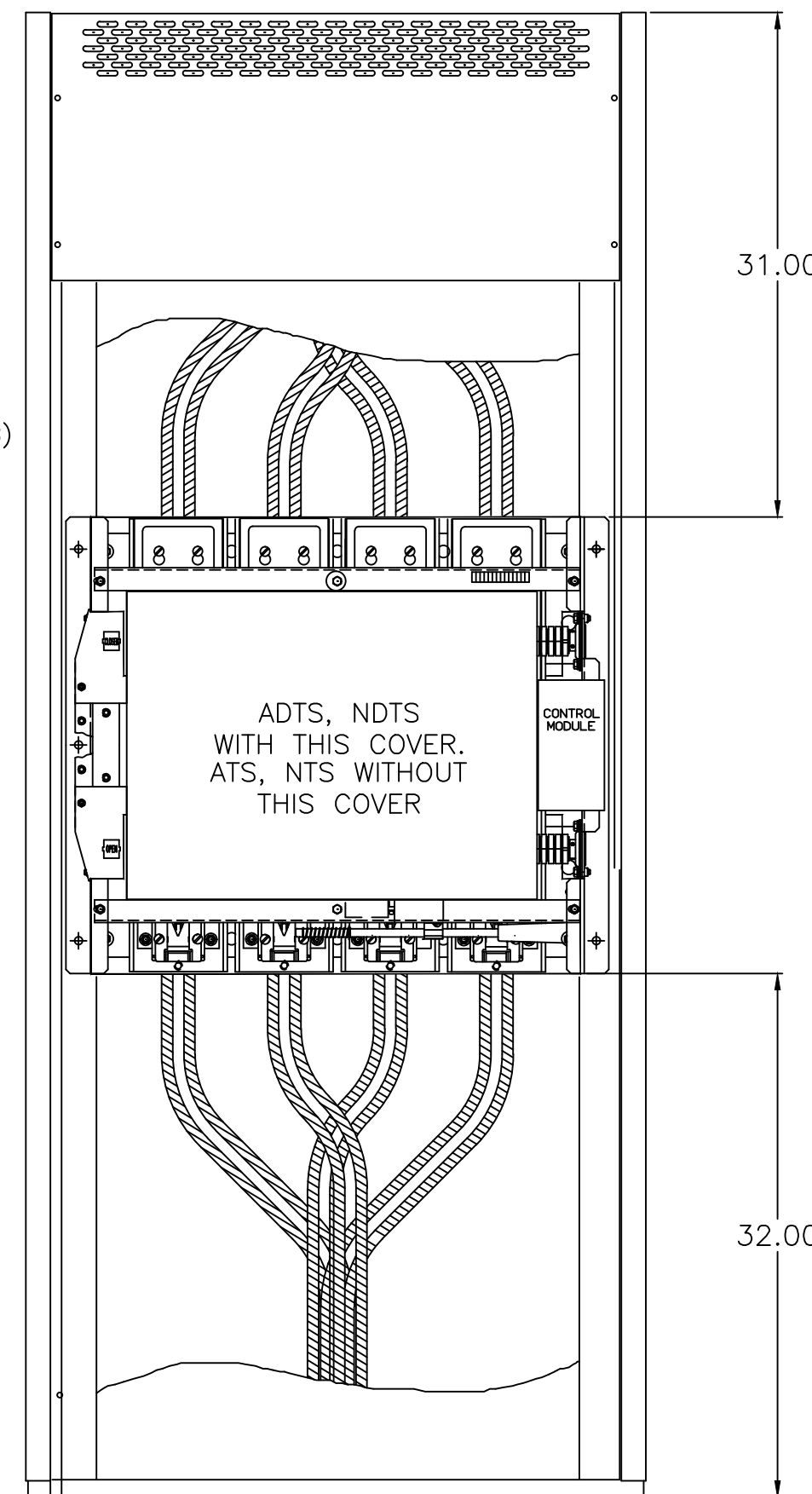
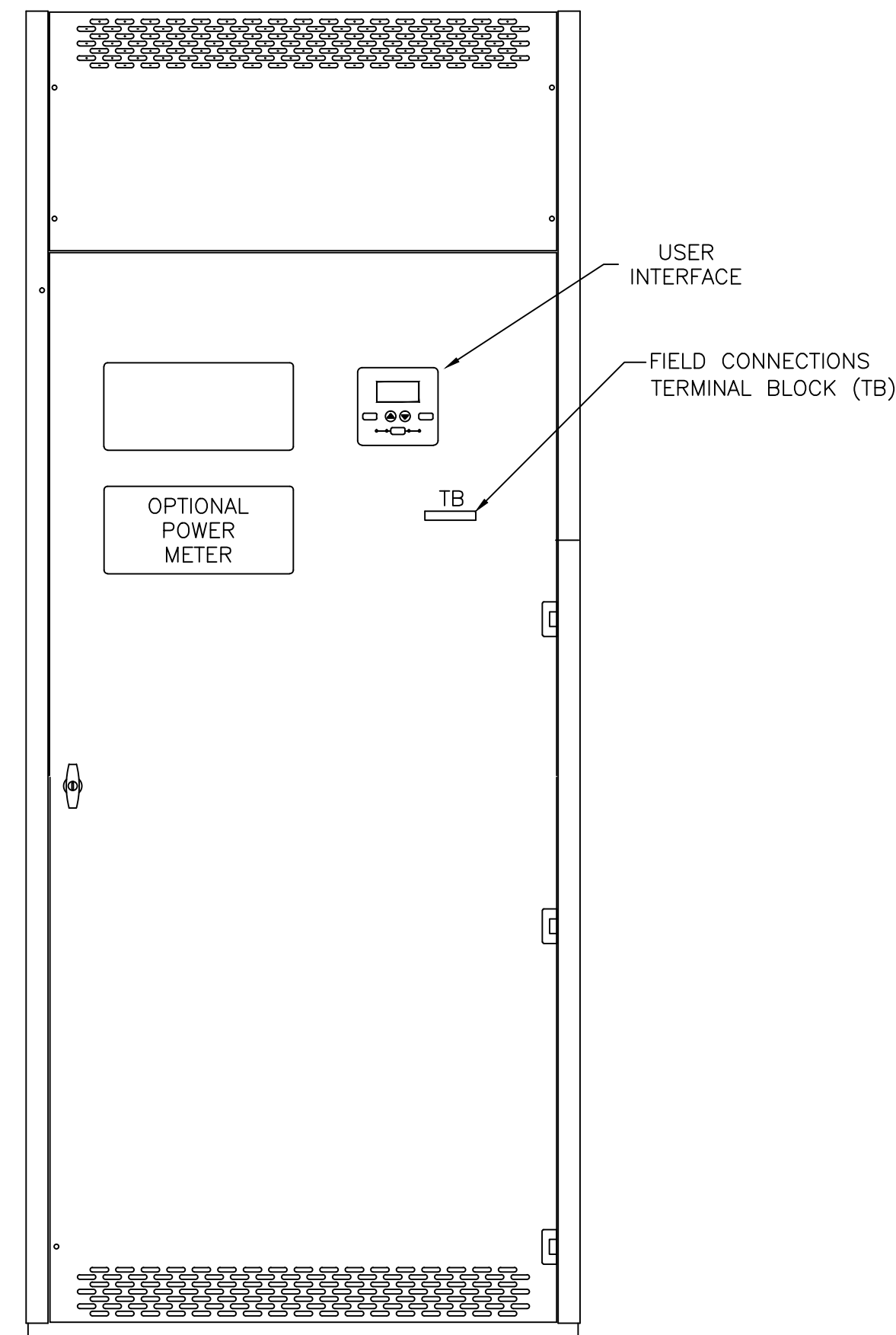

FRONT VIEW WITH DOOR REMOVED

RIGHT SIDE VIEW

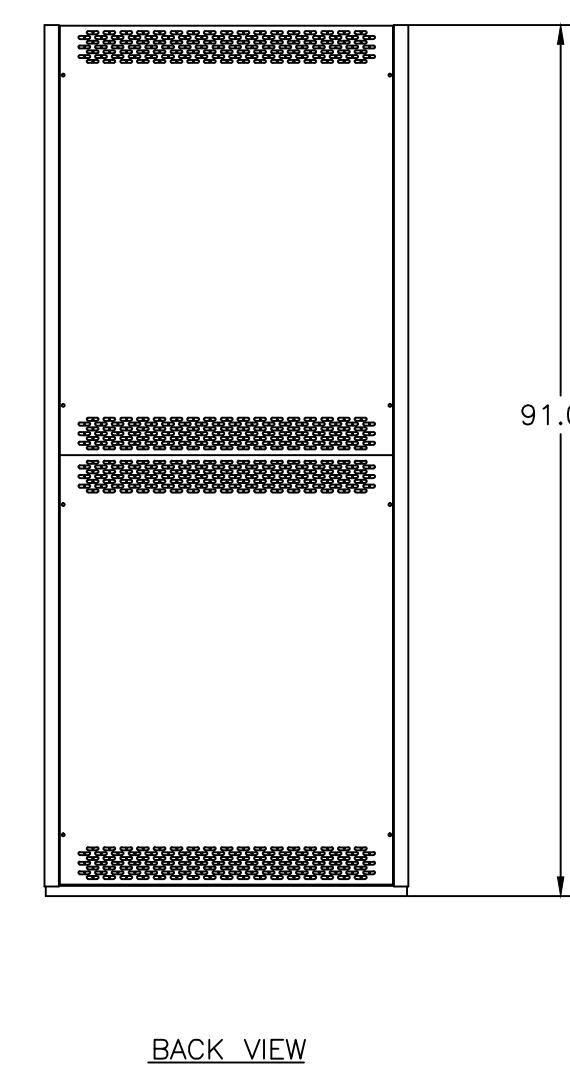
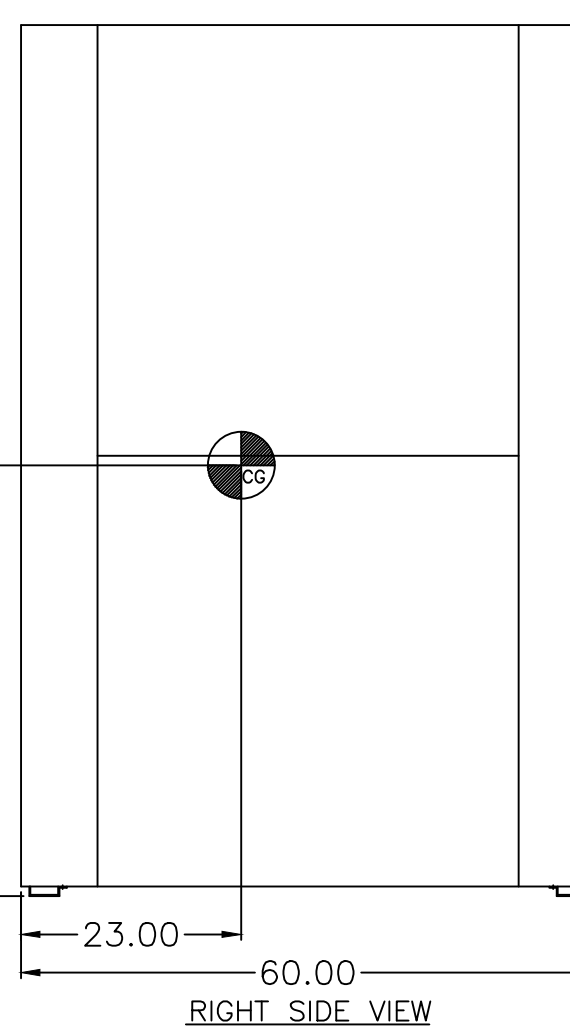
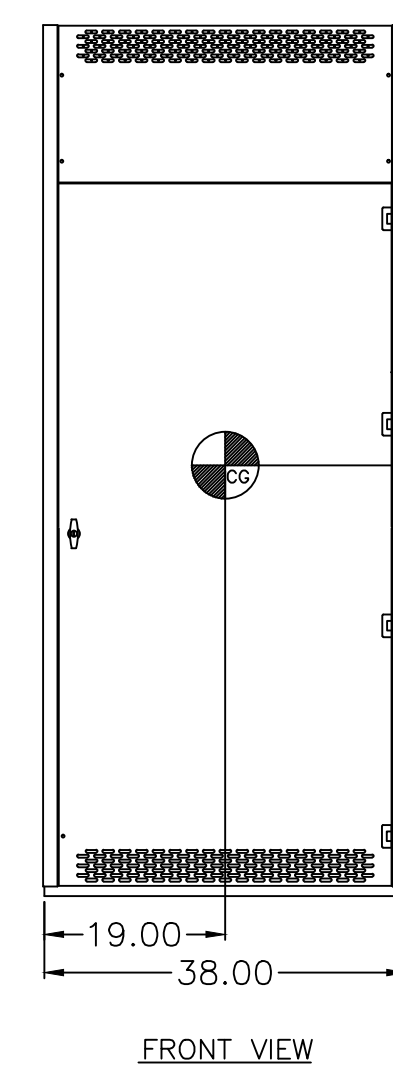

FRONT VIEW

RIGHT SIDE VIEW

BACK VIEW

A	254523	WK	BK	04/29/15
	SEE ECN			
	245879	BWM	BK	12/16/13
	ISSUED			

PROJECT NAME:		REV. TO SHEET	ECN NO.	BY	APP.	DATE
OUTLINE 300 SERIES 2600-3000 AMP (R/C ONLY)						
DRAWN BY	DATE	MANUFACTURING TOLERANCES TO BE IN ACCORDANCE WITH ASCO PROCEDURE MP-1-003. FOR PLASTIC PARTS SEE MP-1-005	ASSEM. REF. NO.	COMPUTER GENERATED DRAWING		
CHECKED	DATE	PROPERTY OF ASCO POWER TECHNOLOGIES. USE PERMITTED FOR OUR WORK ONLY. ALL RIGHTS OF DESIGN OR INVENTION ARE RESERVED.	SCALE	NONE	SIZE	DS
PROJECT APPROVAL						
FINAL APPROVAL	DATE					
DRAWING NO. 1001395-001		DRAWING A		ECN NO. 254523	SHEET 1 OF 1	
 ASCO ® ASCO POWER TECHNOLOGIES, L.P. FLORHAM PARK, NEW JERSEY 07932 U.S.A.						