

GENERAL NOTES

- TYPE 1 ENCLOSURE. FREE STANDING. FLOOR MOUNTED. CODE GAUGE FORMED FRAME CONSTRUCTION.
- NEC STANDARD GAUGE PAN TYPE DOOR WITH LOCKABLE HANDLE.
- FINISH: ANSI #1 GRAY. POLYESTER POWDER STANDARD. OTHER ANSI COLORS AVAILABLE CONSULT FACTORY, UL RECOGNIZED.
- CONSTRUCTION IS IN ACCORDANCE WITH APPLICABLE REQUIREMENTS OF UL 1008.
- RECOMMENDED CLEARANCES:
FRONT: 36 INCHES
- A 20% RATED GROUND BUS IS PROVIDED.
- UNIT IS DESIGNED FOR COMBINATION TOP AND BOTTOM CABLE ENTRY. THE STANDARD SWITCH CONFIGURATION IS FOR TOP ENTRY EMERGENCY & LOAD AND BOTTOM ENTRY NORMAL. OPTIONALLY, THE SWITCH MAY BE SUPPLIED REVERSE SOURCES AND/OR BOTTOM ENTRY LOAD.
(REFER TO THE WIRING DIAGRAM FURNISHED WITH EACH TRANSFER SWITCH TO DETERMINE TERMINATION POSITIONS).
- IMPORTANT NOTE:**
UNDER NO CIRCUMSTANCES SHOULD POWER CABLES BE ROUTED ALONG THE SIDES OF THE TRANSFER SWITCH. AN OPTIONAL CABLE PULL BOX WHICH MOUNTS ON THE LEFT SIDE OF THE ENCLOSURE IS AVAILABLE WHEN CONDITIONS EXIST FOR WHICH CABLES MUST RUN BETWEEN THE TOP AND BOTTOM OF THE UNIT. GROUND CONDUCTORS ONLY MAY BE RUN ALONG THE LEFT SIDEWALL OF THE ENCLOSURE.
- NEUTRAL CONFIGURATIONS:
AN OPTIONAL FULL RATED NEUTRAL CONFIGURATION FOR EACH SOURCE AND THE LOAD MAY BE PROVIDED. WHEN EQUIPPED IT IS IN ONE OF THE FOLLOWING FORMATS AS SPECIFIED BY THE CATALOG NUMBER NO. NEUTRAL TYPE:
(A) SOLID (COPPER BUS) NEUTRAL.
(B) SWITCHED NEUTRAL POLE.
(C) OVERLAPPING NEUTRAL POLE (NOT AVAILABLE ON ACTS/ADTS UNITS).
- NO KNOCKOUTS ARE PROVIDED.
- (OPTIONAL) LEFT SIDE PULL BOX AVAILABLE FOR TOP AND BOTTOM CABLE ACCESS WHEN REQUIRED. CONTACT FACTORY FOR DETAILS AND SHIPPED SEPARATELY.
A. TO ATTACH PULL BOX TO THE LEFT SIDE OF THE ENCLOSURE. REMOVE CONDUIT SIDE COVERS FROM ENCLOSURE. MOVE PULL-BOX INTO POSITION. USE HARDWARE FROM CONDUIT SIDE COVERS TO ATTACH THE PULL-BOX TO ENCLOSURE.

NOTE : CONSULT FACTORY FOR OTHER CABLING & TERMINATION REQUIREMENTS.

APPROXIMATE SHIPPING WEIGHT, LBS (KG)			APPROXIMATE SHIPPING WEIGHT, LBS (KG)		
AMP SIZE	POLES	WEIGHT	AMP SIZE	POLES	WEIGHT
600 TO 1200	2	710 (324)	1600	2	1300 (590)
	B2	740 (337)		B2	1350 (612)
	C2	740 (337)		C2	1350 (612)
	3	740 (337)		3	1350 (612)
	B3	770 (351)		B3	1400 (635)
	C3	770 (351)	C3	1400 (635)	

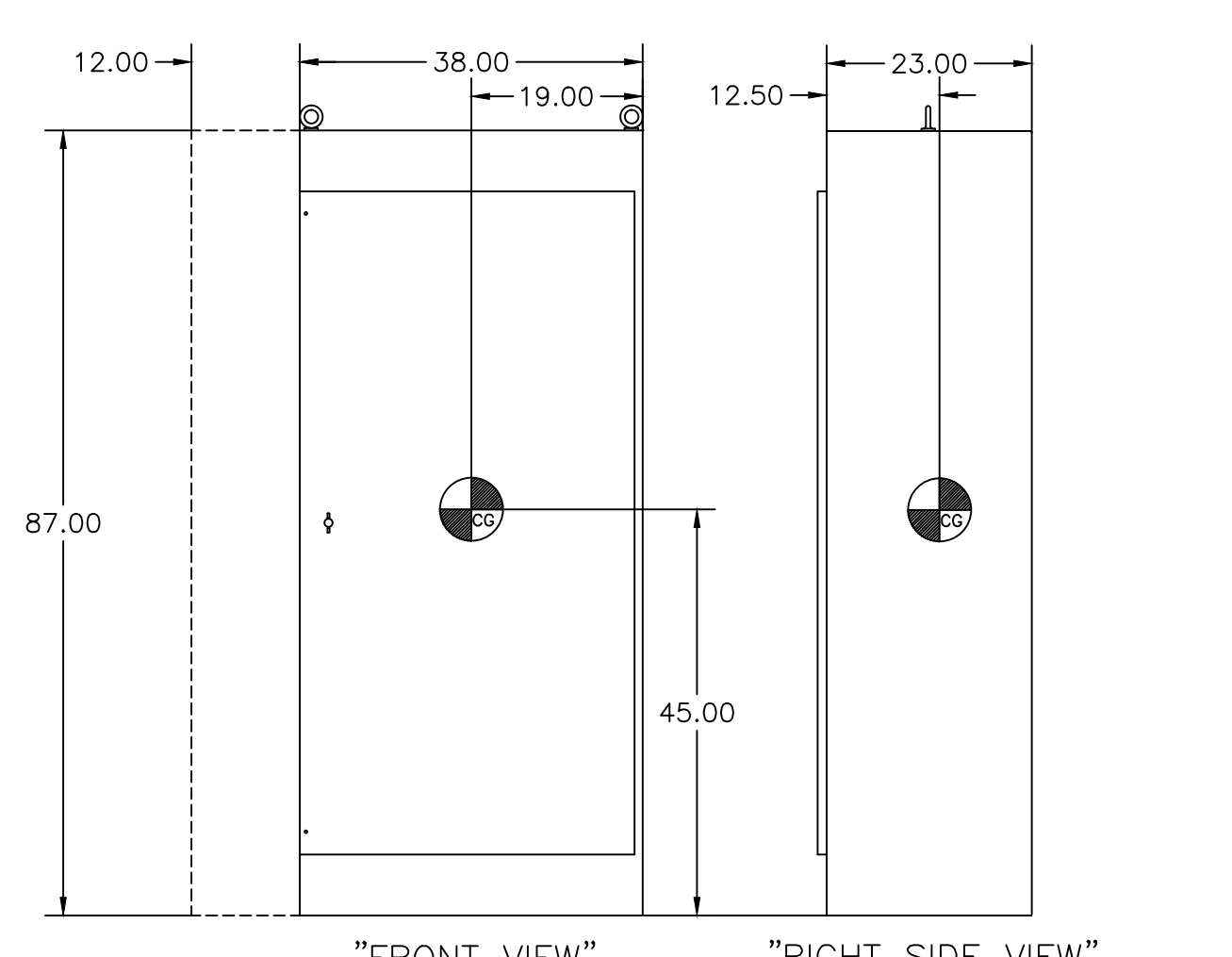
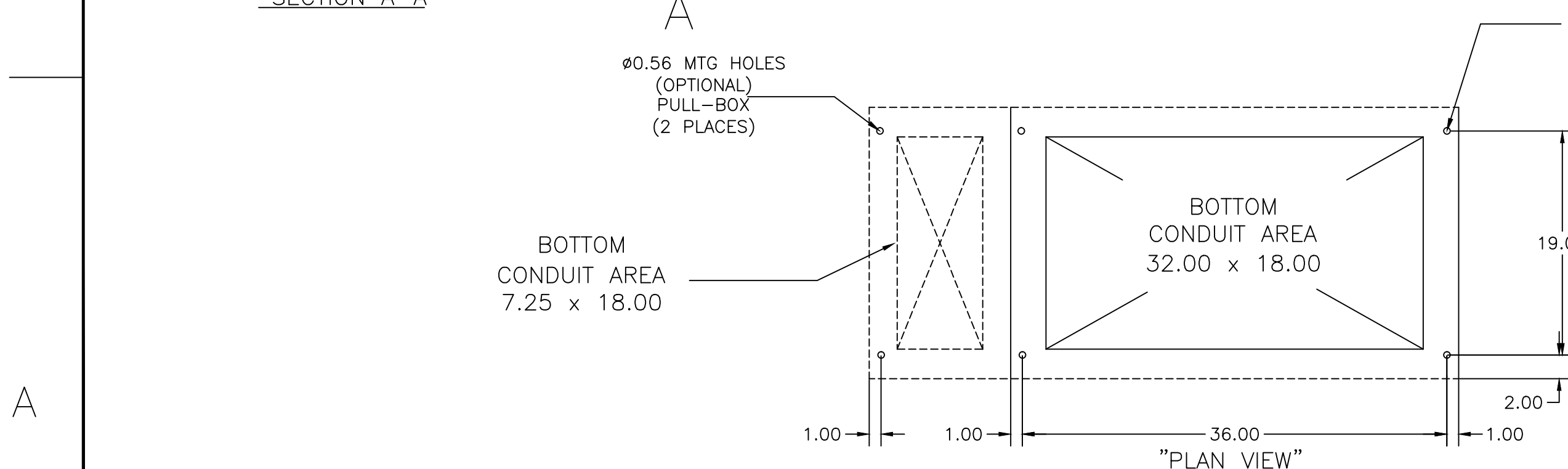
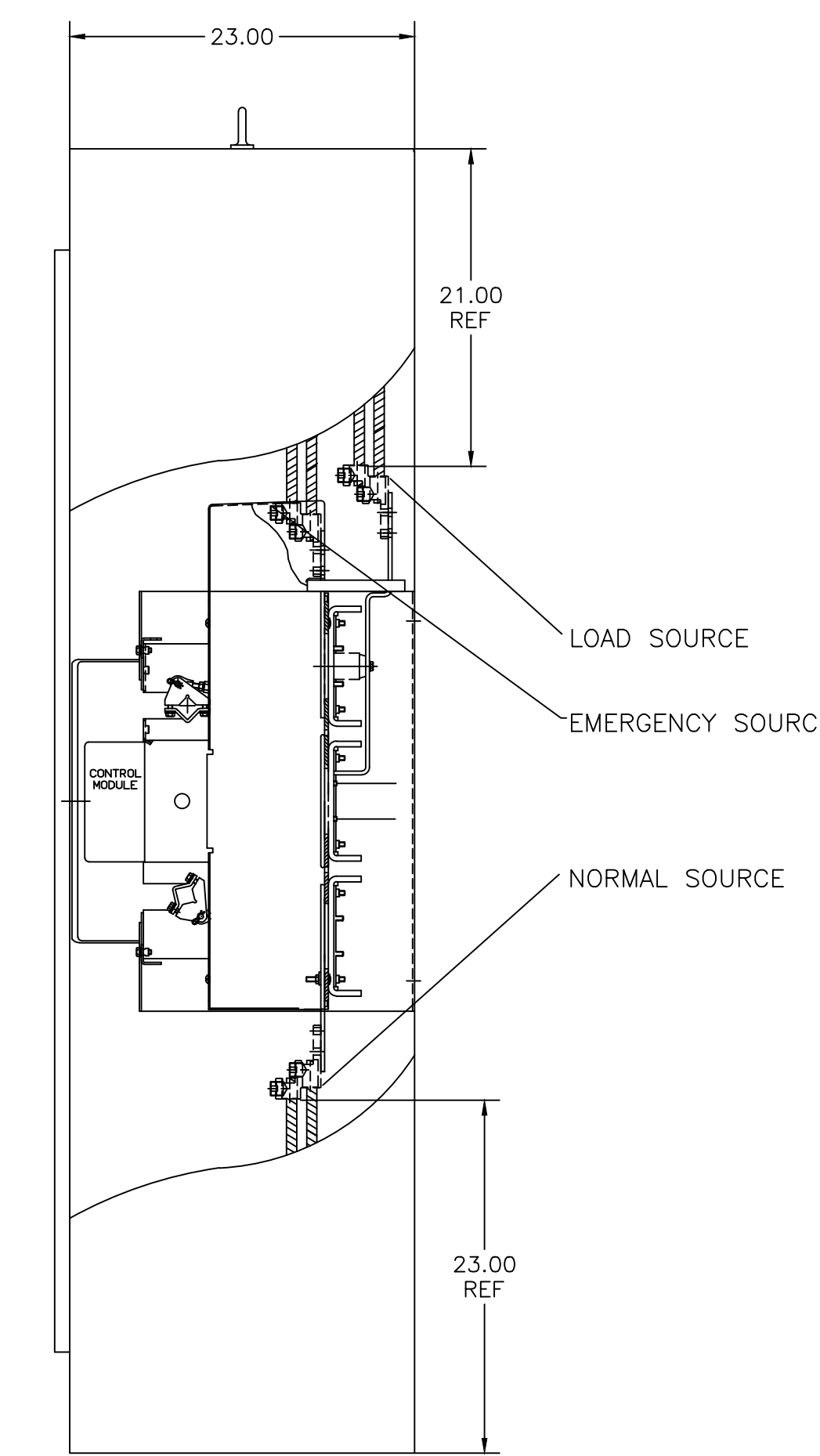
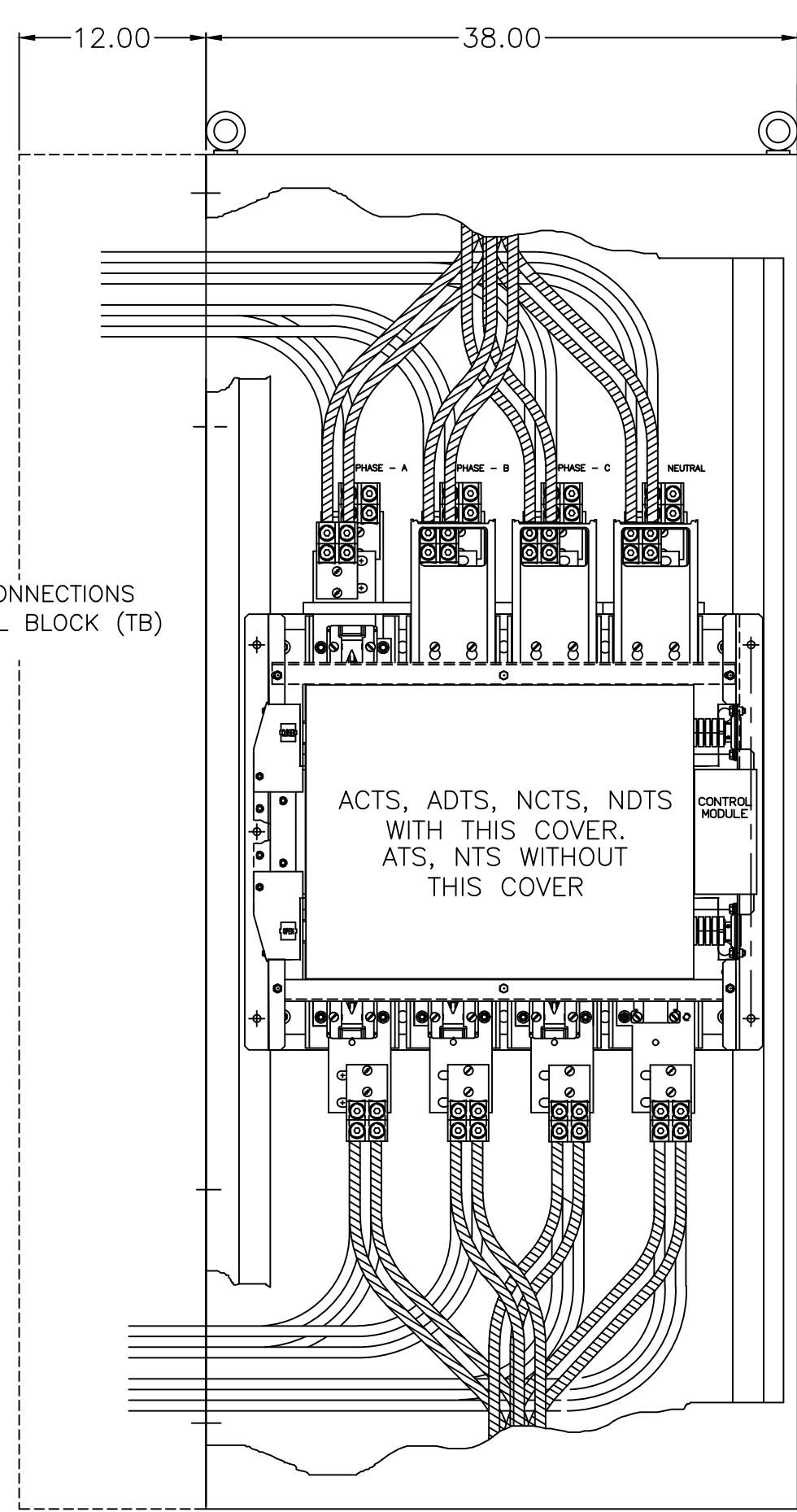
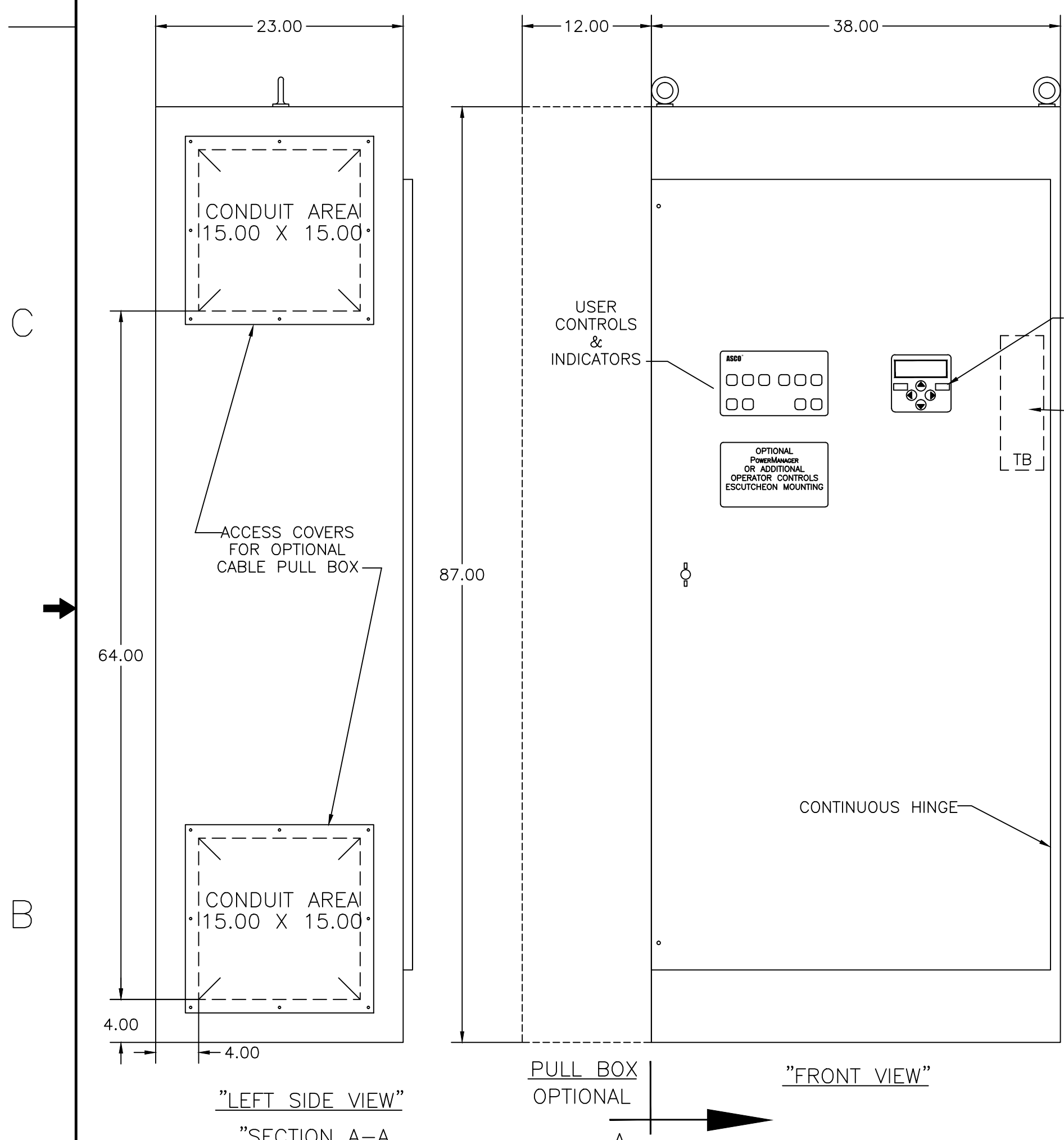
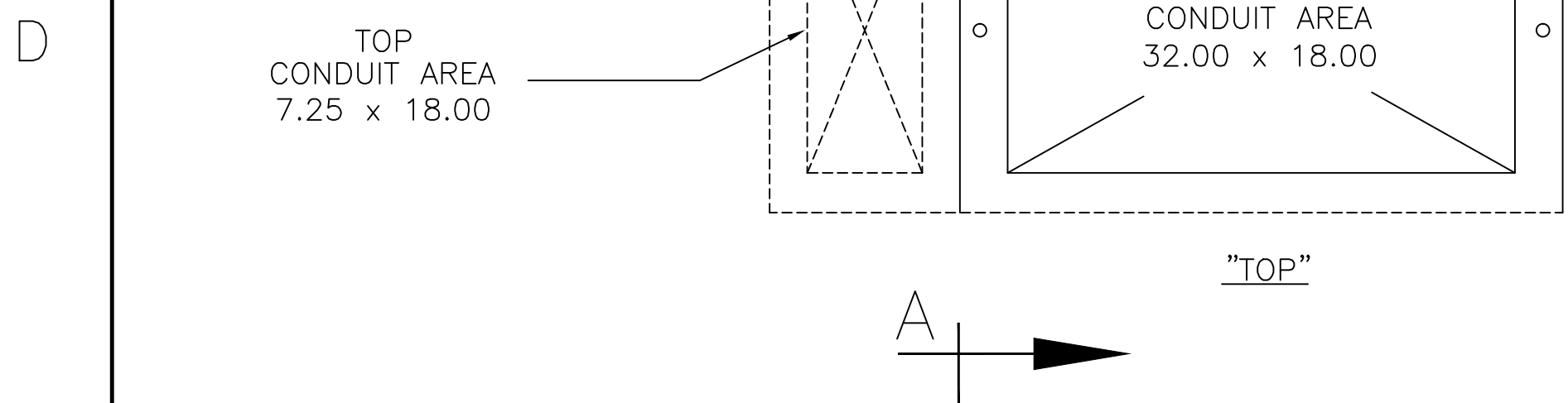
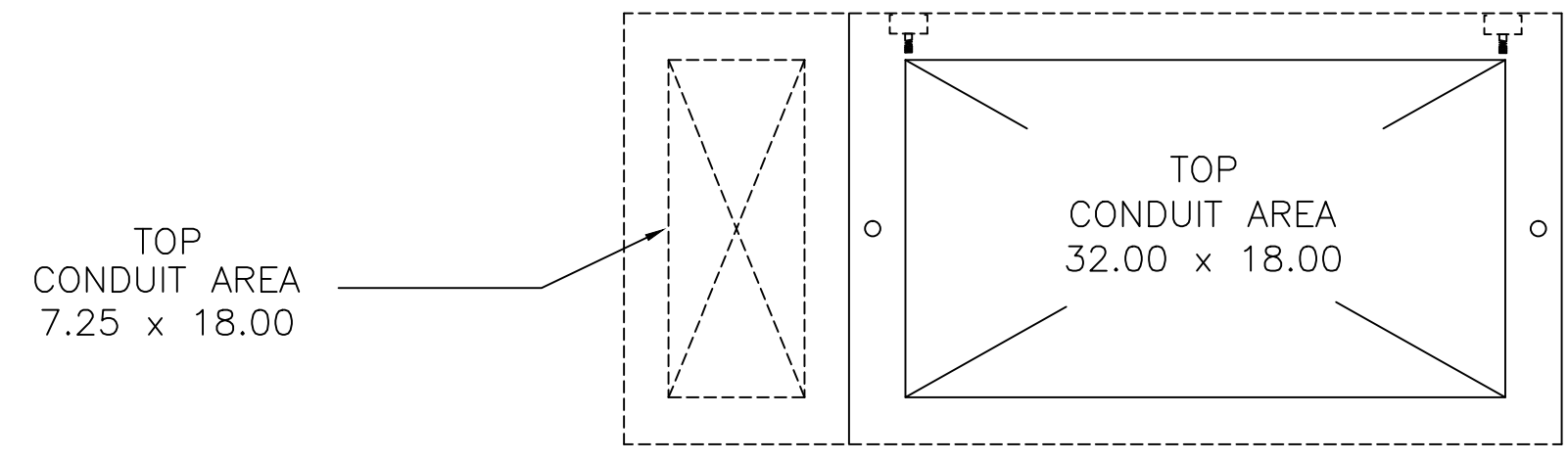

- SPECIFICATIONS**
- SYSTEM RATING: 600 AMPS, 800 AMPS, 1000 AMPS, 1200 AMPS, 1600 AMPS, 3Ø, 4W.
 - GROUND BUS- 20% AMPS
 - NEUTRAL BUS: 100% RATED.
 - APPLICABLE LABELS U.L.1008

SHORT CIRCUIT RATING 600 AMPS - 1600 AMPS

SHORT CIRCUIT RATING WHEN PROTECTED BY A CIRCUIT BREAKER WITHOUT AN ADJUSTABLE SHORT TIME RESPONSE: 65,000 RMS SYM @ 480V.

SHORT CIRCUIT RATING WHEN PROTECTED BY A CIRCUIT BREAKER WITH AN ADJUSTABLE SHORT TIME RESPONSE, MAXIMUM 0.50 SECONDS: 50,000 RMS SYM @ 480V.

THE NORMAL & EMERGENCY SOURCE INPUT MUST BE PROTECTED BY A REMOTE OVERCURRENT PROTECTION DEVICE AS LISTED ON THE MARKINGS ON THE TRANSFER SWITCH.

- CABLING NOTES**
- ALL SIZES SUPPLIED STANDARD WITH MECHANICAL (SCREW TYPE) LUGS.
A. LUG MATERIAL: ALUMINUM ALLOY 6061-T6 WITH ELECTRO TIN PLATED FINISH.
B. SCREW MATERIAL: ALUMINUM ALLOY 6262-T9 WITH ELECTRO TIN PLATED FINISH.
C. UL LISTED, CSA CERTIFIED.
D. LUG SCREW TIGHTENING TORQUE PER UL 486B: 19 FT-LBS.
E. SUITABLE WIRE BENDING SPACE IS PROVIDED.
 - OPTIONAL COPPER CRIMP LUGS MAY BE SUPPLIED. CONSULT FACTORY FOR UL APPROVED OPTIONS.

- CABLING NOTES 600 AMPS - 1200 AMPS**
- SUPPLIED WITH STANDARD MECHANICAL (SCREW TYPE) LUGS ON NORMAL, EMERGENCY AND LOAD BUS STABS. ONE (1) LUG PER PHASE AND NEUTRAL EACH SUITABLE FOR CONNECTION OF FOUR (4) 300MCM-600MCM CU/AL CABLE.
A. SUITABLE WIRE BENDING SPACE IS PROVIDED PER NEC
 - OPTIONAL LUGS MAY BE SUPPLIED. CONSULT FACTORY.
 - GROUND LUGS ARE PROVIDED STANDARD AS FOLLOWS;
(12) 1/0 - 750MCM CU/AL CABLE

- CABLING NOTES 1600 AMPS**
- SUPPLIED WITH STANDARD MECHANICAL (SCREW TYPE) LUGS ON NORMAL, EMERGENCY AND LOAD BUS STABS. ONE (1) LUG PER PHASE AND NEUTRAL EACH SUITABLE FOR CONNECTION OF SIX (6) 300MCM-600MCM CU/AL CABLE.
A. SUITABLE WIRE BENDING SPACE IS PROVIDED PER NEC
 - OPTIONAL LUGS MAY BE SUPPLIED. CONSULT FACTORY.
 - GROUND LUGS ARE PROVIDED STANDARD AS FOLLOWS;
(18) 1/0 - 750MCM CU/AL CABLE

Autodesk Revit MEP Families available on ASCO Power Technologies web site

REV. TO SHEET	ECN NO.	BY	APP.	DATE
A	255313	TR	BK	6/16/15
	254525	TR	BK	5/6/15
PROJECT NAME:				
OUTLINE				
QATS 600A-1200A, Q SERIES				
TYPE 1, 87 X 38 X 23, F/C ONLY				
DRAWN BY	TR	DATE	5/6/15	MANUFACTURING TOLERANCES TO BE IN ACCORDANCE WITH ASCO PROCEDURE MP-1-003. FOR PLASTIC PARTS SEE MP-1-005.
CHECKED	BK	DATE	5/6/15	PROPERTY OF ASCO POWER TECHNOLOGIES. USE PERMITTED FOR OUR WORK ONLY. ALL RIGHTS OF DESIGN OR INVENTION ARE RESERVED.
PROJECT APPROVAL	BK	DATE	5/6/15	
FINAL APPROVAL				
SCALE		NONE		
SIZE		DS		
DWG. NO.		1079096		
DRAWING A		ECN NO. 255313		
REV.		SHEET 1 OF 1		