

OUTLINE FOR ASCO® 4000 & 7000 SERIES 600 AMPERE "J" FRAME (ATS,ACTS,ADTS) FRONT CONNECTED TRANSFER SWITCHES TYPE 1 ENCLOSURE

D

C

B

A

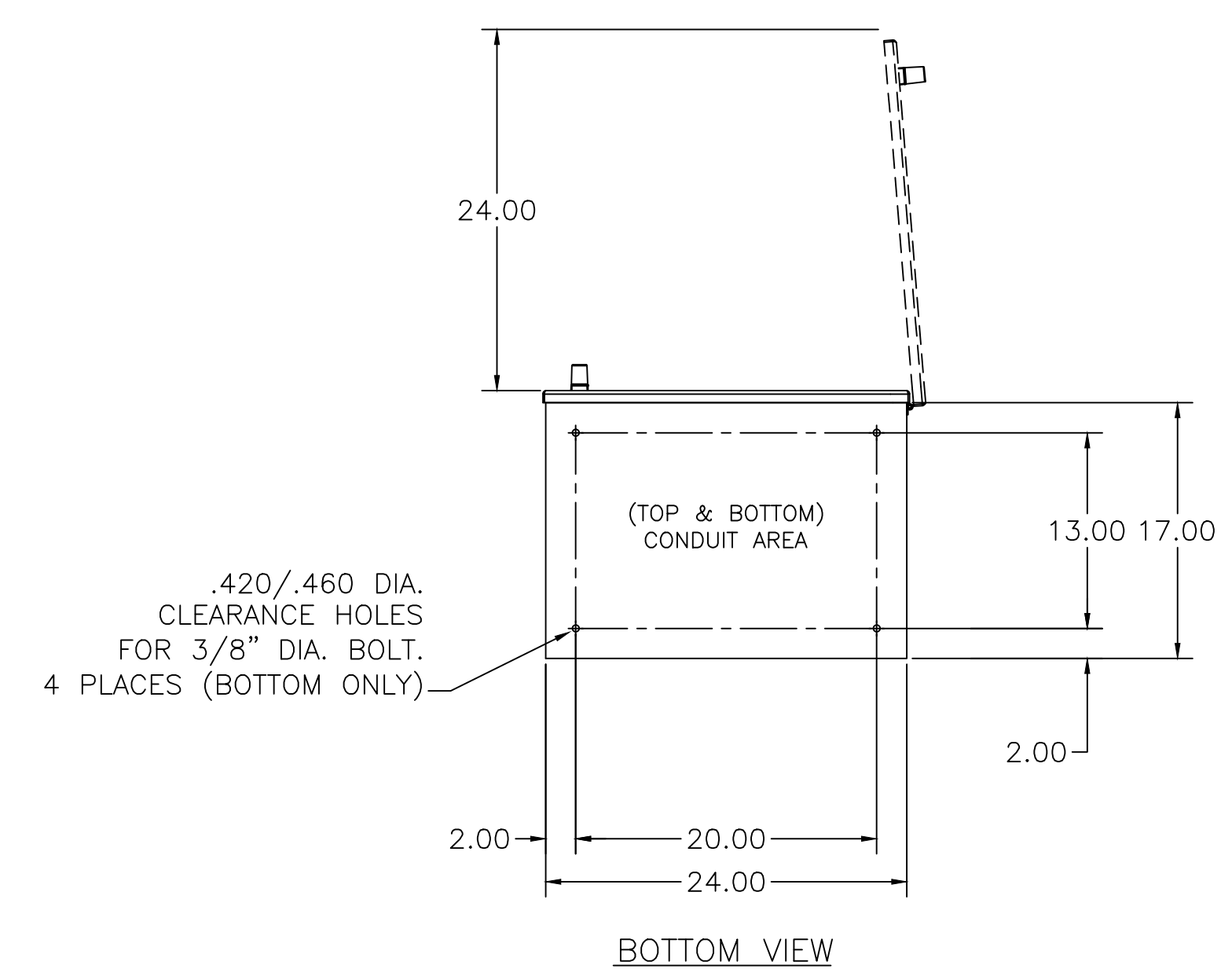
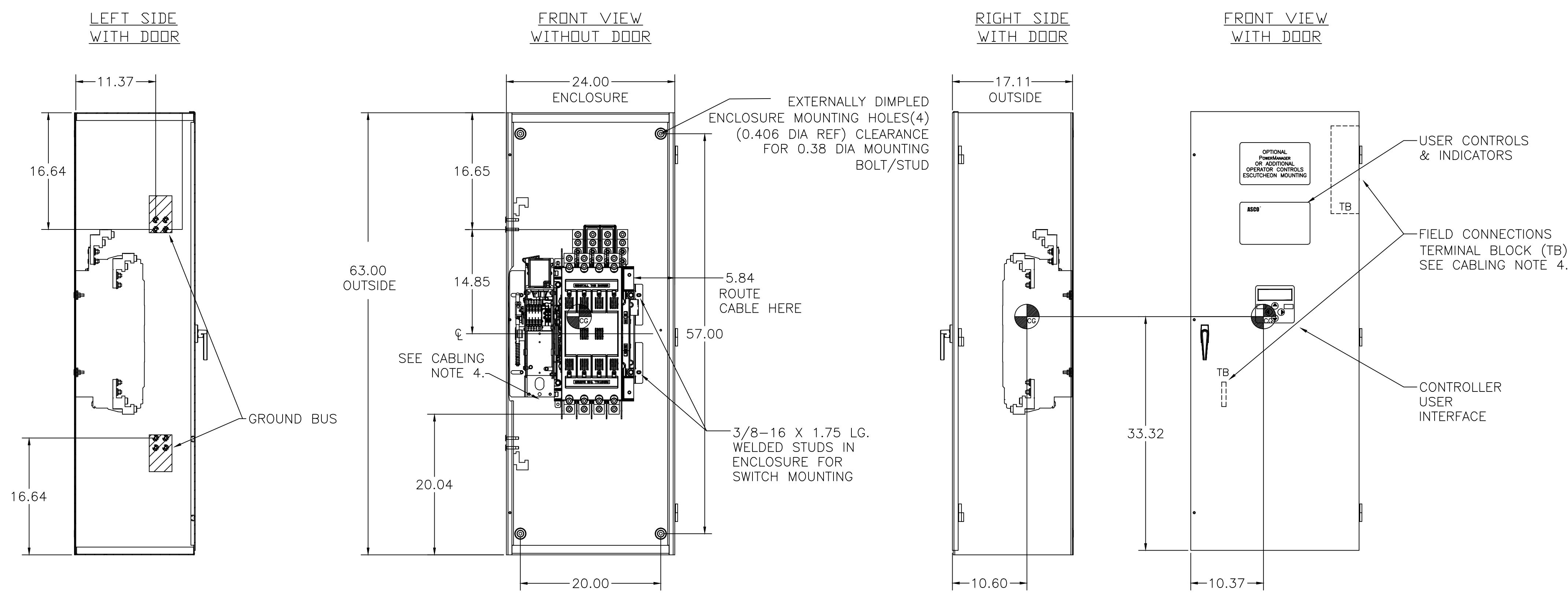

GENERAL NOTES

- TYPE 1 ENCLOSURE, FREE STANDING, FLOOR MOUNTED OR WALL MOUNTED. 12 GAUGE CONSTRUCTION.
- NEC STANDARD GAUGE PAN TYPE DOOR WITH LOCKABLE HANDLE.
- FINISH: ANSI 61 GRAY, POLYESTER POWDER STANDARD. OTHER ANSI COLORS AVAILABLE CONSULT FACTORY UL RECOGNIZED.
- RECOMMENDED CLEARANCES:
FRONT: 24 INCHES
- A 20% RATED GROUND BUS IS PROVIDED.
- UNIT IS DESIGNED FOR COMBINATION TOP AND BOTTOM CABLE ENTRY. THE STANDARD SWITCH CONFIGURATION IS FOR TOP LUGS EMERGENCY AND LOAD AND BOTTOM LUGS NORMAL. OPTIONALLY, THE SWITCH MAY BE SUPPLIED WITH REVERSE NORMAL & EMERGENCY LUGS. (REFER TO THE WIRING DIAGRAM FURNISHED WITH EACH TRANSFER SWITCH TO DETERMINE TERMINATION POSITIONS).
- A FULL RATED NEUTRAL CONNECTION FOR EACH SOURCE AND THE LOAD IS OPTIONAL. WHEN PROVIDED IT IS IN ONE OF THE FOLLOWING FORMATS AS SPECIFIED BY THE CATALOG NO. NEUTRAL TYPE:
A. SOLID (COPPER BUS) NEUTRAL
B. SWITCHED NEUTRAL POLE
C. OVERLAPPING NEUTRAL POLE (NOT AVAILABLE ON 7ACTS/ADTS UNITS)
- ⊕ CENTER OF GRAVITY.

CABLING NOTES

- ALL SIZES SUPPLIED STANDARD WITH MECHANICAL (SCREW TYPE) LUGS. (SEE AMP SIZE BELOW)
A. LUG MATERIAL: ALUMINUM ALLOY 6061-T6 WITH ELECTRO TIN PLATED FINISH.
B. SCREW MATERIAL: ALUMINUM ALLOY 6262-T9 WITH ELECTRO TIN PLATED FINISH.
C. UL LISTED, CSA CERTIFIED.
D. LUG SCREW TIGHTENING TORQUE PER UL 486B: 19 FT-LBS.
E. SUITABLE WIRE BENDING SPACE IS PROVIDED. (SEE AMP SIZE BELOW)
- CONSULT FACTORY FOR OTHER TERMINATION REQUIREMENTS.
- GROUND LUGS ARE PROVIDED STANDARD AS FOLLOWS. (SEE AMP SIZE BELOW)
- CUSTOMER TERMINAL BLOCKS:
FOR ALL 7000 SERIES AND 4000 SERIES ACTS, ADTS, NCTS, & NDTS UNITS THE TB WILL BE MOUNTED ON THE UPPER RIGHT INSIDE OF ENCLOSURE.
FOR 4000 SERIES ATS AND NTS UNITS TB WILL BE MOUNTED ON THE TRANSFER SWITCH FRAME AS INDICATED.

NOTES 600 AMP SWITCHES

- SUPPLIED WITH STANDARD MECHANICAL (SCREW TYPE) LUGS ON THE NORMAL, EMERGENCY & LOAD BUS STABS. ONE (1) LUG PER PHASE AND NEUTRAL EACH SUITABLE FOR CONNECTION OF TWO (2) #2 -600MCM CU/AL CABLES.
A. SUITABLE WIRE BENDING SPACE IS PROVIDED FOR UP TO TWO (2) 600MCM CABLE PER TERMINAL PER NEC.
- GROUND LUGS ARE PROVIDED STANDARD AS FOLLOWS;
SIX (6) #2 -600MCM CU/AL CABLE CONNECTIONS.

ATS SWITCH RATING (AMPS)	POLES	WEIGHTS LB (KG)
600	2	225 (102)
600	C2	232 (105)
600	3	232 (105)
600	C3	239 (108)
600	4	239 (126)

CTS/DTS SWITCH RATING (AMPS)	POLES	WEIGHTS LB (KG)
600	2	241 (109)
600	C2	N/A
600	3	248 (112)
600	C3	N/A
600	4	255 (116)

SERIES	CATALOG PREFIX
4000	4ATS
	4NTS
	4ACTS
	4NCTS
	4ADTS
7000	4NDTS
	7ATS
	7NTS
	7ACTS
	7NCTS
	7ADTS
	7NDTS

G	246848	TR	BK	2/20/14
	SEE ECN			
F	237284	WK	BK	05/24/12
	SEE ECN			
E	219811	TR	WK	09/05/08
	SEE ECN			
D	216867	WK	WK	02/14/08
	SEE ECN			
C	210654	MJB	BK	10/31/06
	SEE ECN			
B	209625	WK	BK	08/03/06
	SEE ECN			
A	205984	BWM	BWM	9/21/05
	SEE ECN			
-	205148	BWM	JPB	8/05
	ISSUED			

PROJECT NAME: **COMPOSITE OUTLINE**

7000 SERIES TS "J" 600 AMP TYPE 1

MANUFACTURING TOLERANCES TO BE IN ACCORDANCE WITH ASCO PROCEDURE MP-1-003. FOR PLASTIC PARTS SEE MP-1-005.

PROPERTY OF ASCO POWER TECHNOLOGIES. USE PERMITTED FOR OUR WORK ONLY. ALL RIGHTS OF DESIGN OR INVENTION ARE RESERVED.

SCALE: NONE SIZE DS

COMPUTER GENERATED DRAWING

DWG. NO. **780146**

DRAWING G ECN NO. 246848 SHEET 1 OF 1

ASCO® ASCO POWER TECHNOLOGIES, L.P. FLOHAM PARK, NEW JERSEY 07932 U.S.A.