

FIELD CONNECTIONS

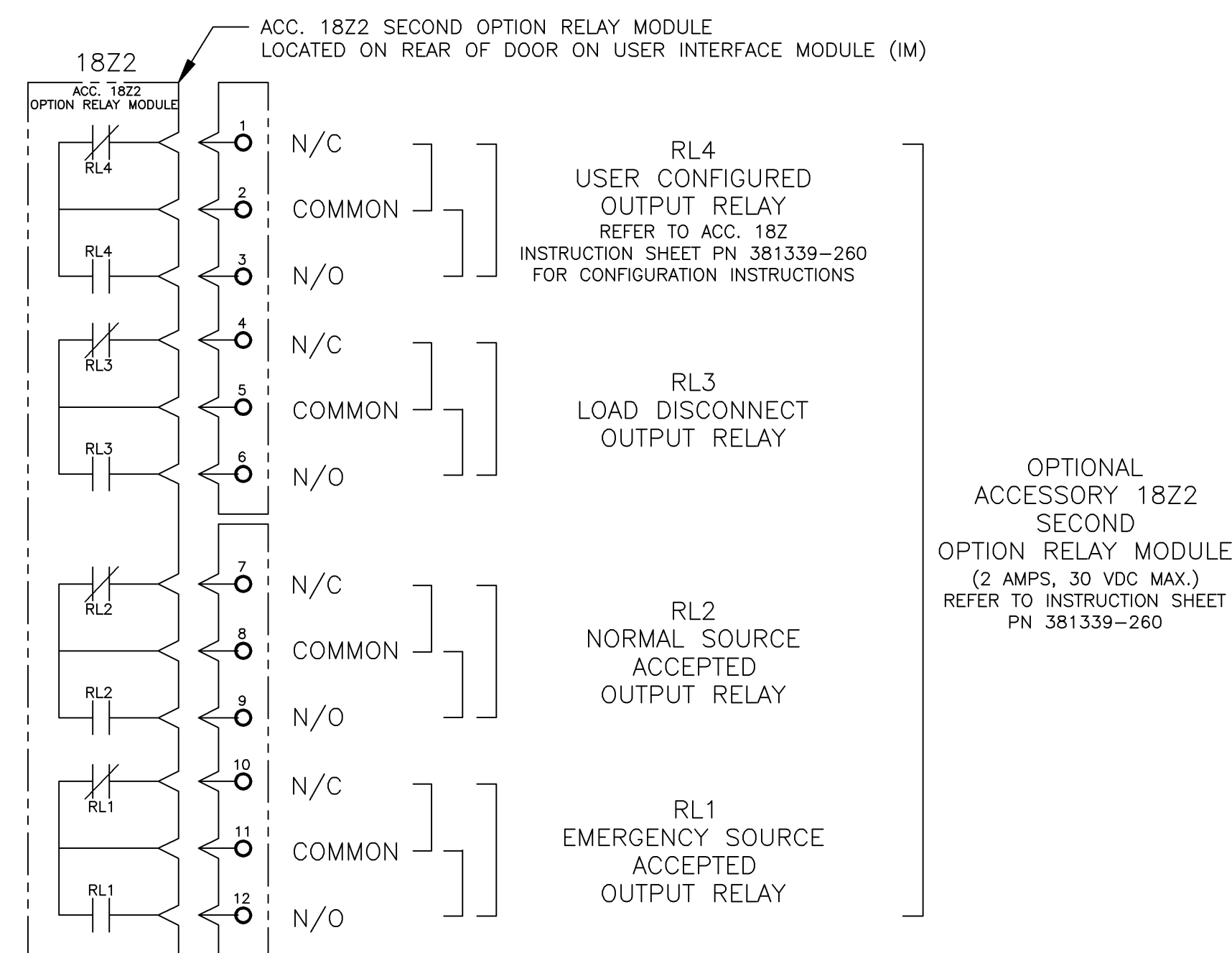
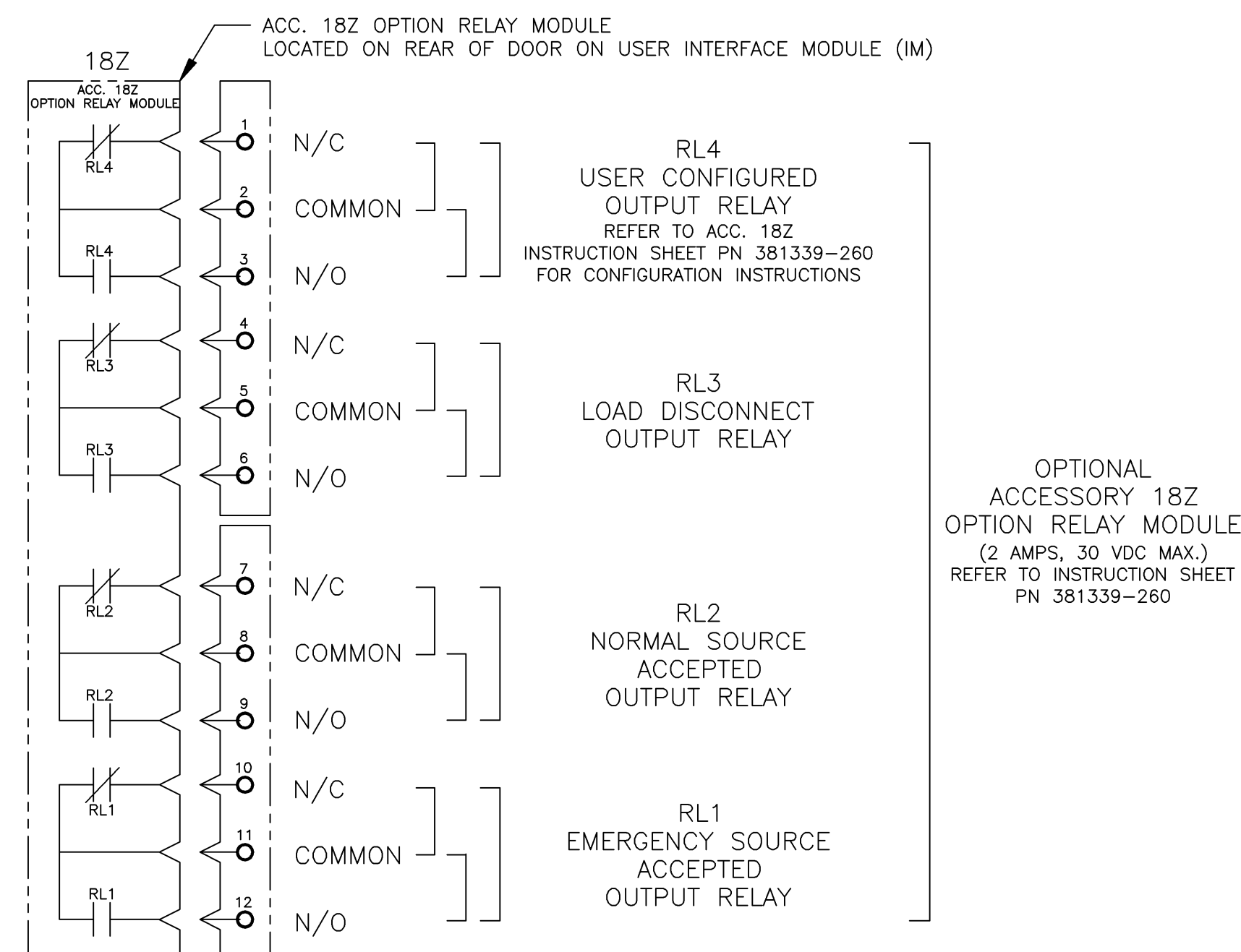
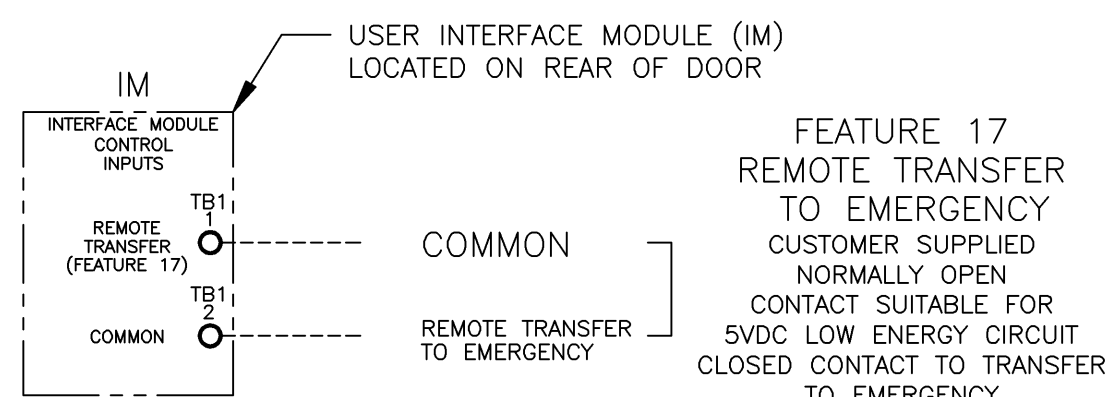
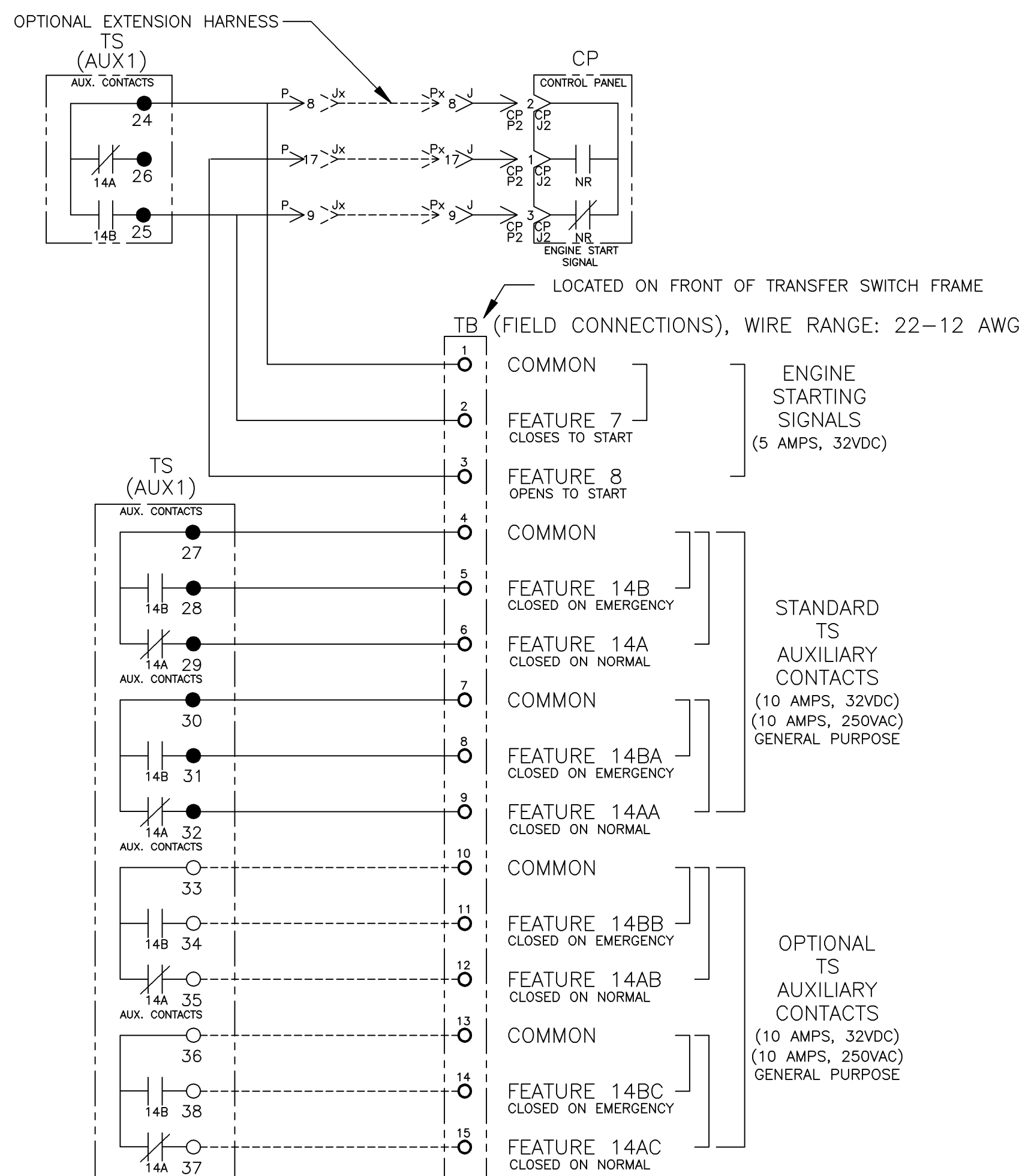

221384 TR WK 1/13/09		ISSUE	BY	APP.	DATE
PROJECT NAME:		REV. TO SHEET	ECN NO.	BY	APP.
WIRING DIAGRAM		THIRD ANGLE PROJECTION			
4000 SERIES (G4A/NTS) 3PH 4000 AMPS "G" FRAME, GROUP 5 CONTROLS					
DRAWN BY	TR	DATE	1/13/09	MANUFACTURING TOLERANCES TO BE IN ACCORDANCE WITH ASCO PROCEDURE MP-1-003. FOR PLASTIC PARTS SEE MP-1-055	ASSEM. REF. NO.
CHECKED	BK	DATE	1/13/09	PROPERTY OF ASCO POWER TECHNOLOGIES. USE PERMITTED FOR OUR WORK ONLY. ALL RIGHTS OF DESIGN OR INVENTION ARE RESERVED.	COMPUTER GENERATED DRAWING
PROJECT APPROVAL	WK	DATE	1/13/09		SCALE 1:1 SIZE DS
FINAL APPROVAL					DWG. NO. 861888
			ASCO POWER TECHNOLOGIES, L.P. FLORHAM PARK, NEW JERSEY 07932 U.S.A.		
DRAWING REV.		ECN NO.	221384	SHEET 2 OF 6	

MAIN POWER POLES

TS OPERATOR CIRCUIT

EMERGENCY

NORMAL

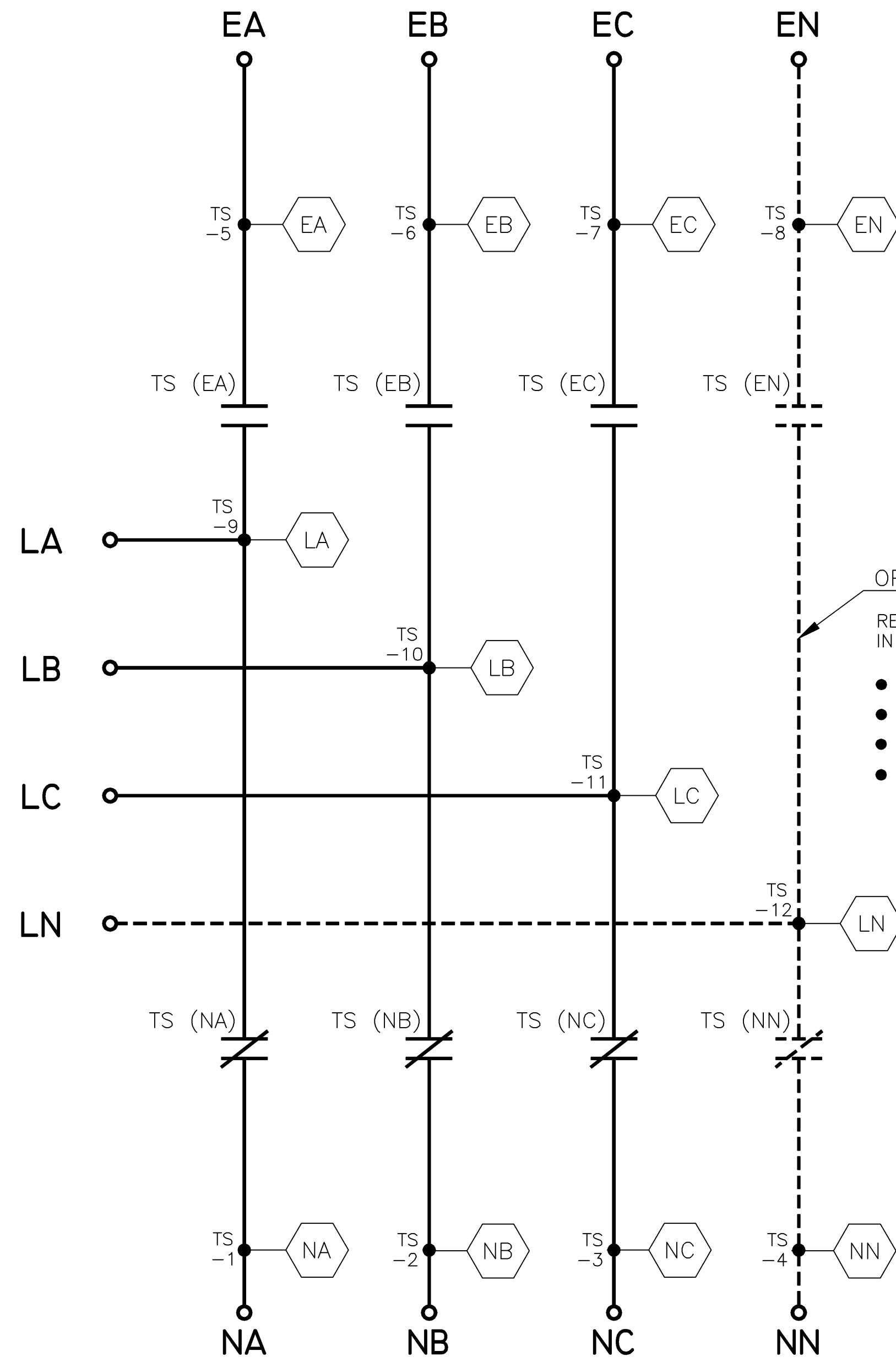

OPTIONAL NEUTRAL TYPES
 REFER TO "EXPLANATION OF CATALOG NUMBER CODES"
 IN CATALOG NUMBER CHART ON SHEET 1.

- NONE
- SWITCHING
- OVERLAPPING CONTACTS
- SOLID BUS PLATE

NOTE:
 ATS/NTS SHOWN CLOSED ON
 NORMAL SOURCE.

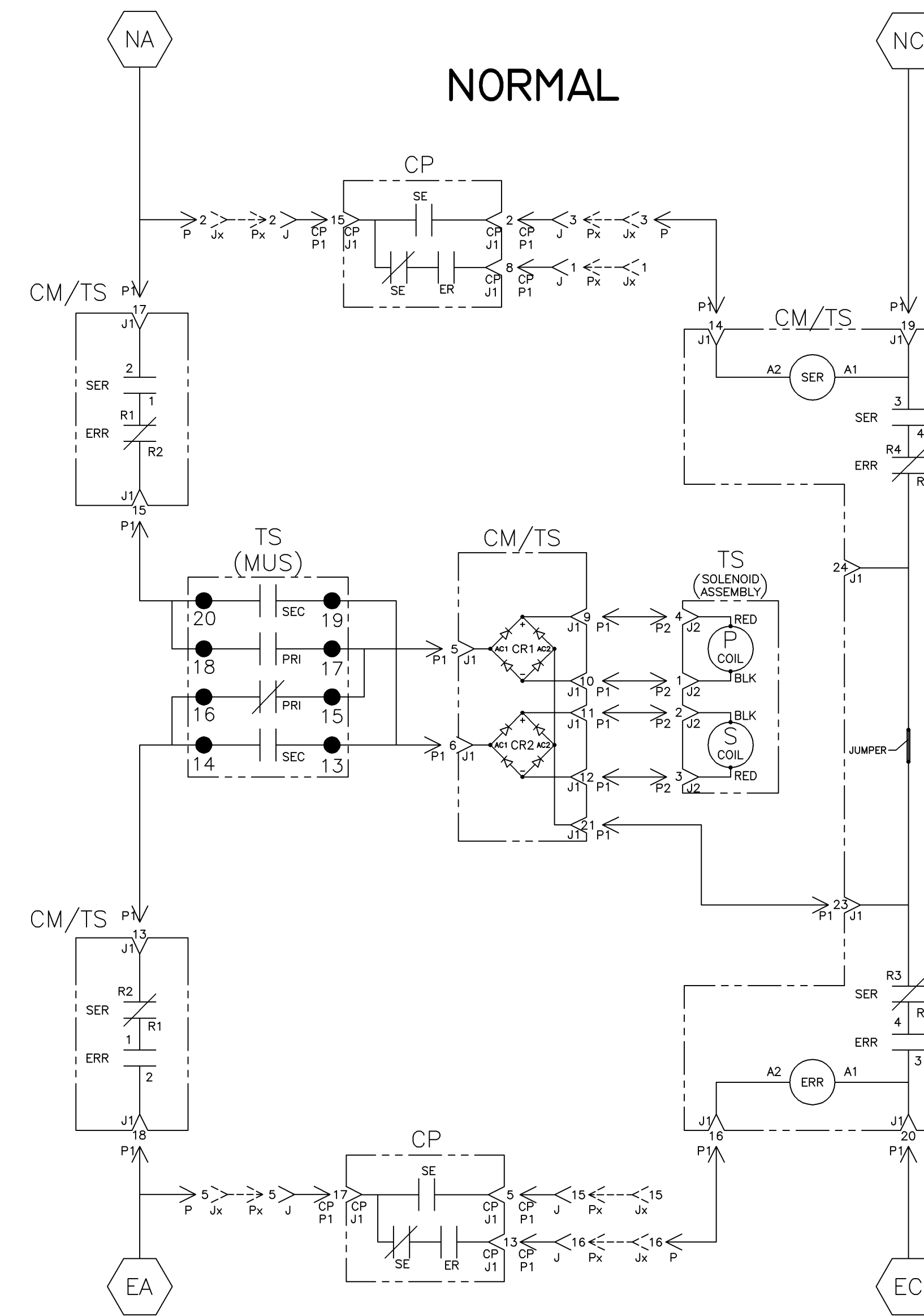

TS (MUS) CONTACTS					
MUS	SOLENOID POSITION				
	NORM	>	AFTER TDC	<	EMER
13-14					
15-16					
17-18					
19-20					

* AFTER SOLENOID PASSES THROUGH TOP DEAD CENTER POSITION.

PROJECT NAME:		221384 TR WK 1/13/09
WIRING DIAGRAM		ISSUE
4000 SERIES (G4A/NTS) 3PH 4000 AMPS		REV. TO SHEET
"G" FRAME, GROUP 5 CONTROLS		ECN NO.
DRAWN BY: TR DATE: 1/13/09		BY: APP. DATE:
CHECKED BY: BK DATE: 1/13/09		ASSEM. REF. NO.
APPROVED BY: WK DATE: 1/13/09		COMPUTER GENERATED DRAWING
FINAL APPROVAL:		SCALE: 1:1 SIZE: DS
ASCO POWER TECHNOLOGIES, L.P.		DWG. NO. 861888
FLORHAM PARK, NEW JERSEY 07932 U.S.A.		DRAWING REV. ECN 221384 SHEET 3 OF 6

NORMAL SOURCE CIRCUITS

ADDITIONAL CIRCUITS

NORMAL

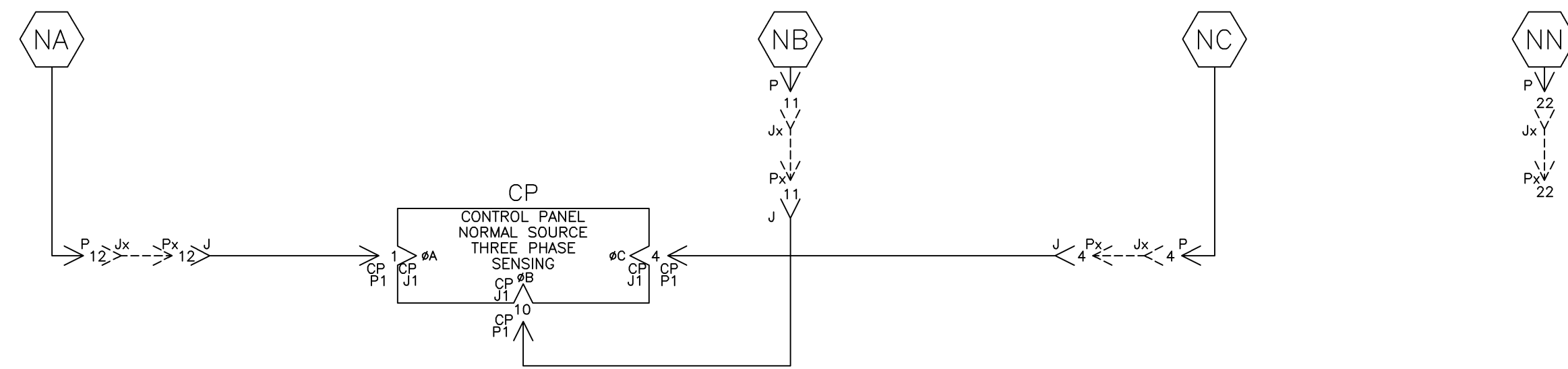

EMERGENCY SOURCE CIRCUITS

EMERGENCY

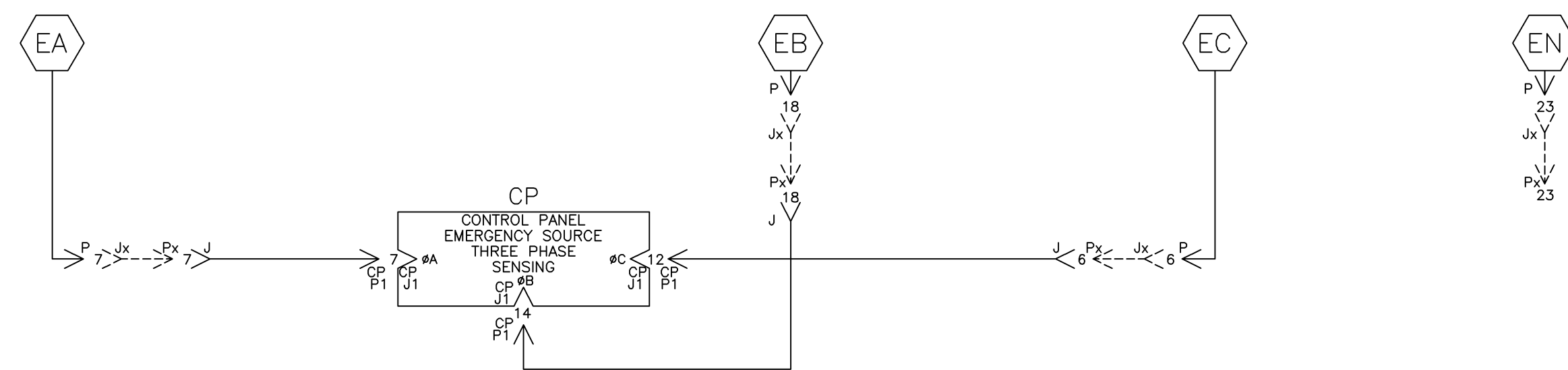

LOAD TERMINAL CIRCUITS

LOAD



CONTROL SIGNALS & INDICATION

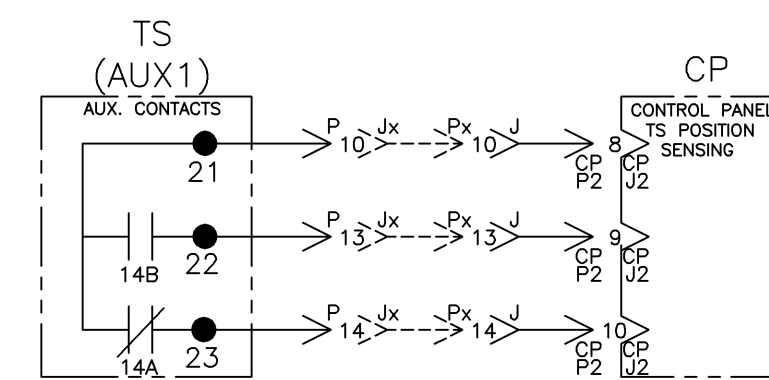

PROJECT NAME:		221384	TR	WK	1/13/09
REV. TO SHEET	ISSUE	ECN NO.	BY	APP.	DATE
WIRING		DIAGRAM			
4000 SERIES (G4A/NTS) 3PH 4000 AMPS					
"G" FRAME, GROUP 5 CONTROLS					
DRAWN BY		TR	DATE	1/13/09	
CHECKED		BK	DATE	1/13/09	
PROJECT APPROVAL		WK	DATE	1/13/09	
FINAL APPROVAL			DATE		
MANUFACTURING TOLERANCES TO BE IN ACCORDANCE WITH ASCO PROCEDURE MP-1-003. FOR PLASTIC PARTS SEE MP-1-055.		ASSEM. REF. NO.		COMPUTER GENERATED DRAWING	
PROPERTY OF ASCO POWER TECHNOLOGIES. USE PERMITTED FOR OUR WORK ONLY. ALL RIGHTS OF DESIGN OR INVENTION ARE RESERVED.		SCALE	1:1	SIZE	DS
ASCOT		861888		SHEET 4 OF 6	
ASCOT		ASCOT		ASCOT	

ASCOT ASCO POWER TECHNOLOGIES, L.P. FLORHAM PARK, NEW JERSEY 07932 U.S.A.

PHYSICAL DIAGRAM

ENCLOSURE

TOP (INSIDE)

D

D

C

C

B

B

A

A

FIELD INTERFACE TERMINAL BLOCK
FOR ACCESSORIES 7, 8, 14A & 14B
(MOUNTED ON FRONT TRANSFER SWITCH FRAME)

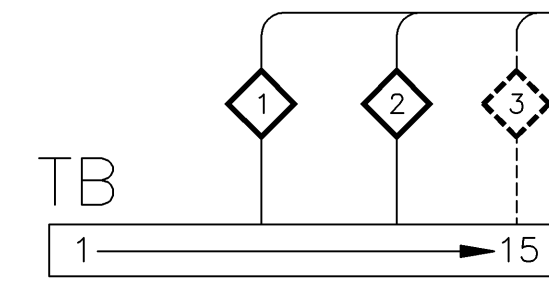

TS (TRANSFER SWITCH)

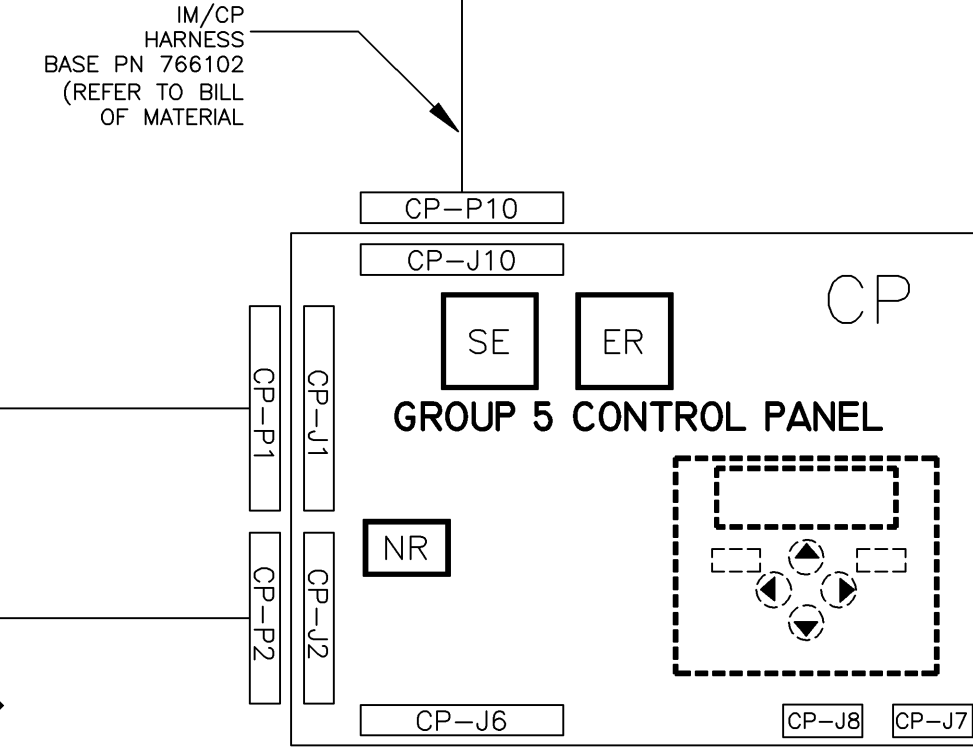
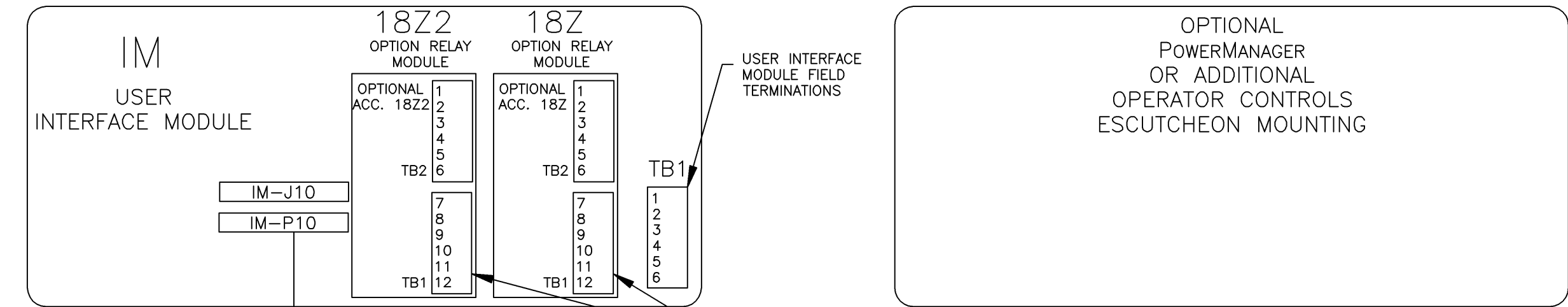
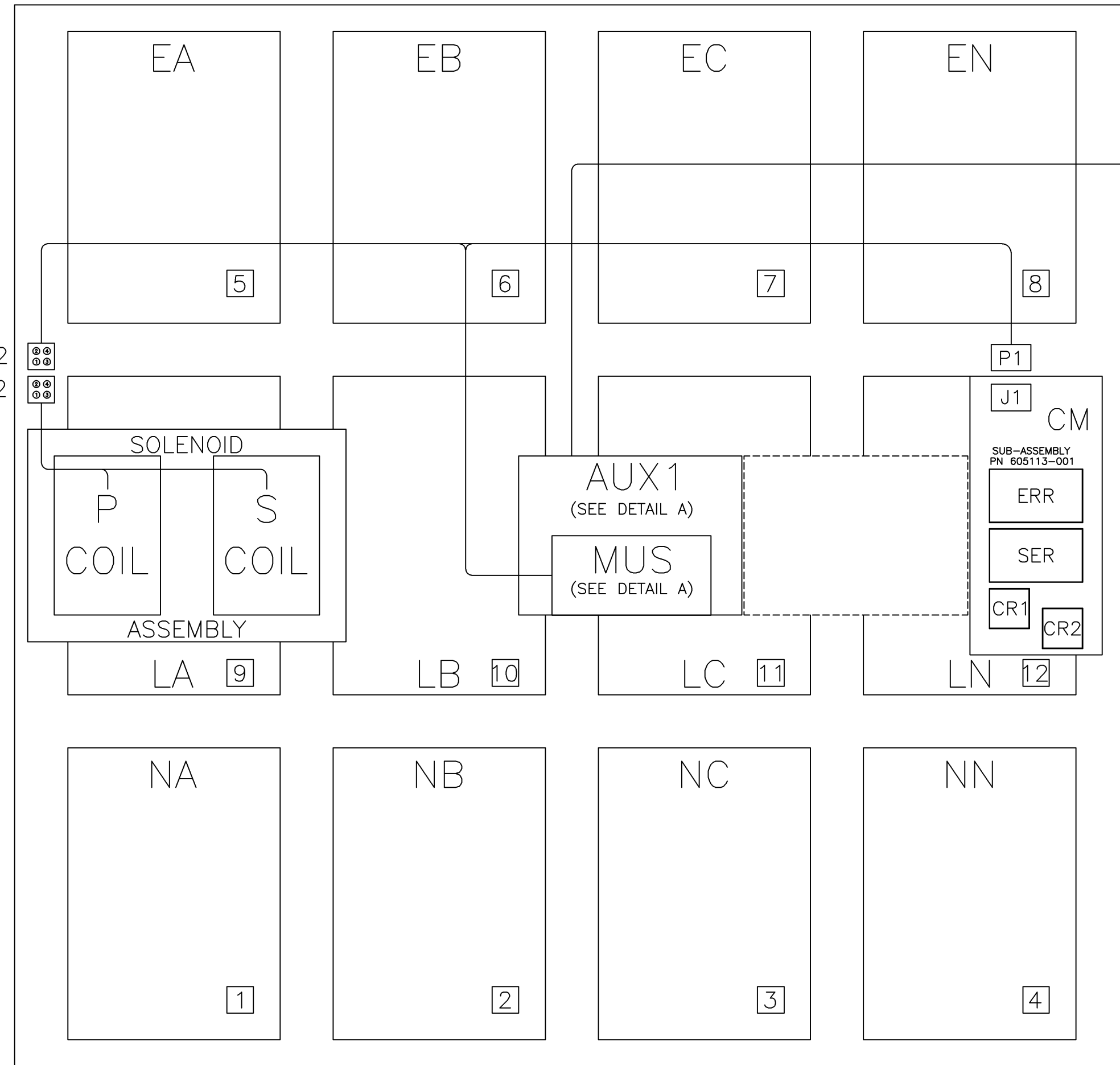

BOTTOM (INSIDE)

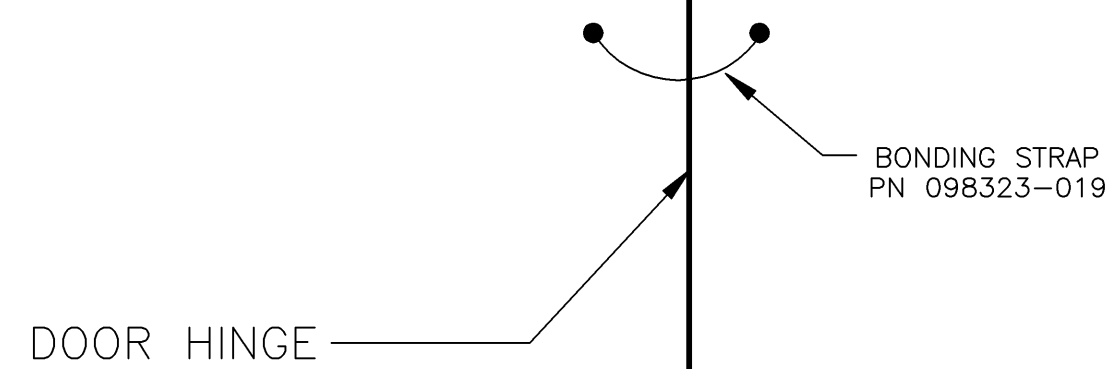
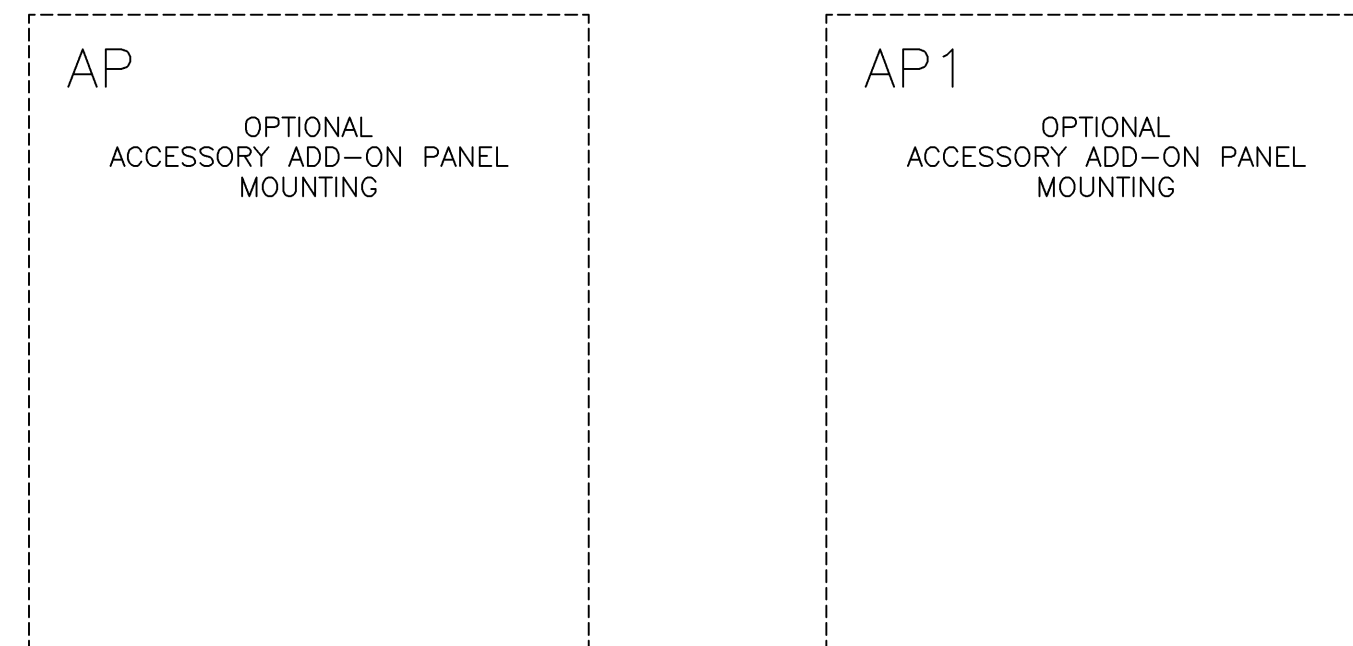

DETAIL A
MUS & AUX1
TOP VIEW

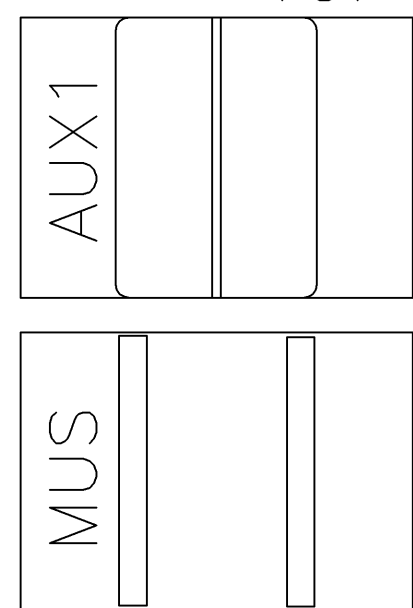

221384 TR WK 1/13/09		ISSUE	
REV. TO SHEET	ECN NO.	BY	APP. DATE
PROJECT NAME: WIRING DIAGRAM		THIRD ANGLE PROJECTION	
4000 SERIES (G4A/NTS) 3PH 4000 AMPS "G" FRAME, GROUP 5 CONTROLS			
BY: TR	DATE: 1/13/09	MANUFACTURING TOLERANCES TO BE IN ACCORDANCE WITH ASCO PROCEDURE MP-I-003. FOR PLASTIC PARTS SEE MP-I-055	ASSEM. REF. NO.
CHECKED: BK	1/13/09	PROPERTY OF ASCO POWER TECHNOLOGIES. USE PERMITTED FOR OUR WORK ONLY. ALL RIGHTS OF DESIGN OR INVENTION ARE RESERVED.	
PROJECT APPROVAL: WK	1/13/09	COMPUTER GENERATED DRAWING	
SCALE: 1:1	SIZE: DS	DWC. NO. 861888	
FINAL APPROVAL:		ASCOSCO POWER TECHNOLOGIES, L.P. FLORHAM PARK, NEW JERSEY 07932 U.S.A.	
DRAWING REV.:	ECN NO. 221384	SHEET 5 OF 6	

WIRE RUN LISTING

WIRE No.	HARNESS 844432 (P1,P2,J3) MAIN TS	CLR	AWG
1	P-2,TS-1		16
2	P-3,P1-14		
3	P-4,TS-3		
4	P-5,TS-5		
5	P-6,TS-7		
6	P-7,TS-5		
6	P-8,TS(AUX1)-24		
6	TS(AUX1)-24,J3-1		
7	P-9,TS(AUX1)-25		
7	TS(AUX1)-25,J3-2		
8	P-10,TS(AUX1)-21		
9	P-11,TS-2		
10	P-12,TS-1		
11	P-13,TS(AUX1)-22		
12	P-14,TS(AUX1)-23		
13	P-16,P1-16		
14	P-17,J3-3		
15	P-18,TS-6		
16	P-19,TS-9		
17	P-20,TS-10		
18	P-21,TS-11		
19	P-22,TS-4		
20	P-23,TS-8		
21	P-24,TS-12		
22	P1-5,TS(MUS)-17		
22	TS(MUS)-17,TS(MUS)-15		
23	P1-6,TS(MUS)-19		
23	TS(MUS)-19,TS(MUS)-13		
24	P1-9,P2-4		
25	P1-10,P2-1		
26	P1-11,P2-2		
27	P1-12,P2-3		
28	P1-13,TS(MUS)-16		
28	TS(MUS)-16,TS(MUS)-14		
29	P1-15,TS(MUS)-20		
29	TS(MUS)-20,TS(MUS)-18		
30	P1-17,TS-1		
4	P1-18,TS-5		
3	P1-19,TS-3		
5	P1-20,TS-7		
30	P1-21,P1-23		
REMOVE WIRES			
6	TS(AUX1)-24,J3-1		
7	TS(AUX1)-25,J3-2		
14	P-17,J3-3		
ADD WIRES			
6	TS(AUX1)-24,TB-1		
7	TS(AUX1)-25,TB-2		
200	P-1		
14	P-17,TB-3		
222	P-15		
201	P1-1		
202	P1-2		
203	P1-3		
204	P1-4		
205	P1-7		
206	P1-8		
207	P1-16		
208	P1-22		
209	P1-24		

WIRE No.	TS STD. AUX. CONTACTS	CLR	AWG
40	TB-4,TS(AUX1)-27		16
41	TB-5,TS(AUX1)-28		
42	TB-6,TS(AUX1)-29		
43	TB-7,TS(AUX1)-30		
44	TB-8,TS(AUX1)-31		
45	TB-9,TS(AUX1)-32		

WIRE No.	OPTIONAL AUX. CONTACTS	CLR	AWG
46	TB-10,TS(AUX1)-33		16
47	TB-11,TS(AUX1)-34		
48	TB-12,TS(AUX1)-35		
49	TB-13,TS(AUX1)-36		
50	TB-14,TS(AUX1)-38		
51	TB-15,TS(AUX1)-37		

WIRE No.	HARNESS 483763 (J,CP-P1,CP-P2) CONTROL PANEL	CLR	AWG
350	J-1,CP-P1-8		18
1	J-2,CP-P1-15		
2	J-3,CP-P1-2		
3	J-4,CP-P1-4		
4	J-5,CP-P1-17		
5	J-6,CP-P1-12		
4	J-7,CP-P1-7		
6	J-8,CP-P2-2		
7	J-9,CP-P2-3		
8	J-10,CP-P2-8		
9	J-11,CP-P1-10		
10	J-12,CP-P1-1		
11	J-13,CP-P2-9		
12	J-14,CP-P2-10		
200	J-15,CP-P1-5		
13	J-16,CP-P1-13		
14	J-17,CP-P2-1		
15	J-18,CP-P1-14		
ADD WIRES			
16	J-19		
17	J-20		
18	J-21		
19	J-22		
20	J-23		
21	J-24		

WIRE No.	HARNESS 309320-005 OPTIONAL 8 IN. EXTENSION HARNESS	CLR	AWG
350	Jx-1,Px-1		16
1	Jx-2,Px-2		
2	Jx-3,Px-3		
3	Jx-4,Px-4		
4	Jx-5,Px-5		
5	Jx-6,Px-6		
4	Jx-7,Px-7		
6	Jx-8,Px-8		
7	Jx-9,Px-9		
8	Jx-10,Px-10		
9	Jx-11,Px-11		
10	Jx-12,Px-12		
11	Jx-13,Px-13		
12	Jx-14,Px-14		
200	Jx-15,Px-15		
13	Jx-16,Px-16		
14	Jx-17,Px-17		
15	Jx-18,Px-18		
16	Jx-19,Px-19		
17	Jx-20,Px-20		
18	Jx-21,Px-21		
19	Jx-22,Px-22		
20	Jx-23,Px-23		
21	Jx-24,Px-24		

WIRE No.	ADDITIONAL WIRING	CLR	AWG
----------	-------------------	-----	-----

PROJECT NAME: WIRING DIAGRAM		221384 TR WK 1/13/09
ISSUE	BY APP. DATE	ECN NO.
 THIRD ANGLE PROJECTION		
DRAWN BY: TR CHECKED: BK PROJECT APPROVAL: WK FINAL APPROVAL:	DATE: 1/13/09 1/13/09 1/13/09	MANUFACTURING TOLERANCES TO BE IN ACCORDANCE WITH ASCO PROCEDURE MP-I-003. FOR PLASTIC PARTS SEE MP-I-055. ASSEMB. REF. NO. PROPERTY OF ASCO POWER TECHNOLOGIES. USE PERMITTED FOR OUR WORK ONLY. ALL RIGHTS OF DESIGN OR INVENTION ARE RESERVED. ASCO ASCO POWER TECHNOLOGIES, L.P. FLORHAM PARK, NEW JERSEY 07932 U.S.A.
COMPUTER GENERATED DRAWING SCALE: 1:1 SIZE: DS	DWG. NO.: 861888 DRAWING REV. ECN 221384 SHEET 6 OF 6	