

THREE PHASE WIRING FOR ASCO® 4000 SERIES CLOSED TRANSITION TRANSFER SWITCHES TYPES H4ACTS & H4NCTS RATED 600, 800, 1000 & 1200 AMPERES

FEATURES, SETTINGS, OPERATION, ACCESSORIES & NOTES

THE FOLLOWING FEATURES AND RELATED SETTINGS ARE PART OF THE GROUP 5 CONTROL PANEL'S USER CONFIGURABLE PARAMETERS. FOR DETAILED INFORMATION REGARDING THE CONFIGURATION OF THESE PARAMETERS AND OTHER FEATURES OF THE GROUP 5 CONTROL PANEL, REFER TO THE **GROUP 5 CONTROL PANEL FOR ASCO® 4000 SERIES AUTOMATIC TRANSFER SWITCHES** USER'S GUIDE (PART NO. 381333-126) PROVIDED WITH EVERY 4000 SERIES AUTOMATIC TRANSFER SWITCH.

THE NOMINAL OPERATING VOLTAGE & FREQUENCY IS PRE-PROGRAMMED AT THE FACTORY BASED ON THE NAMEPLATE DATA PRINTED ON THE TRANSFER SWITCH & CONTROL PANEL NAMEPLATES.

VOLTAGE & FREQUENCY SENSING

THE FOLLOWING SETTINGS ARE EXPRESSED AS A PERCENTAGE OF THE CONTROL PANEL'S NOMINAL VOLTAGE SETTING UNLESS STATED OTHERWISE. ALL SETTINGS ARE ADJUSTABLE IN INCREMENTS OF 1%.

A. RMS VOLTAGE SENSING ON ALL PHASES OF THE NORMAL & EMERGENCY SOURCES.

PARAMETER	RANGE OF SETTINGS	DEFAULT SETTING
NORMAL VOLTAGE DROPOUT	70-98%	85%
NORMAL VOLTAGE PICKUP	85-100%	90%
NORMAL OVER VOLTAGE TRIP	102-115%	OFF
NORMAL VOLTAGE UNBALANCE	YES/NO	NO
NORMAL VOLTAGE UNBALANCE DROPOUT	5-20% OF AVG. NORMAL VOLTAGE	20% (if ON)
NORMAL VOLTAGE UNBALANCE PICKUP	3-18% OF AVG. NORMAL VOLTAGE	10% (if ON)
EMERGENCY VOLTAGE DROPOUT	70-98%	75%
EMERGENCY VOLTAGE PICKUP	85-100%	90%
EMERGENCY OVER VOLTAGE TRIP	102-115%	OFF
EMERGENCY VOLTAGE UNBALANCE	YES/NO	NO
EMERGENCY VOLTAGE UNBALANCE DROPOUT	5-20% OF AVG. EMERGENCY VOLTAGE	20% (if ON)
EMERGENCY VOLTAGE UNBALANCE PICKUP	3-18% OF AVG. EMERGENCY VOLTAGE	10% (if ON)

B. FREQUENCY SENSING OF THE NORMAL & EMERGENCY SOURCES.

PARAMETER	RANGE OF SETTINGS	DEFAULT SETTING
NORMAL FREQUENCY DROPOUT	85-98%	90%
NORMAL FREQUENCY PICKUP	90-100%	95%
NORMAL OVER FREQUENCY TRIP	102-110%	OFF
EMERGENCY FREQUENCY DROPOUT	85-98%	90%
EMERGENCY FREQUENCY PICKUP	90-100%	95%
EMERGENCY OVER FREQUENCY TRIP	102-110%	OFF

TIME DELAYS

THE FOLLOWING TIME DELAY SETTINGS ALL HAVE AN ADJUSTABLE RANGE OF 0-60 min 59 sec UNLESS STATED OTHERWISE. ADJUSTABLE IN INCREMENTS OF 1 sec. NOTE: SOME TIME DELAYS MAY BE EFFECTED BY CUSTOMER REQUESTED ACCESSORIES PROVIDED WITH THE UNIT. REFER TO THE DESCRIPTIONS PROVIDED UNDER THE "ACCESSORIES" NOTES ON THIS PAGE.

FEATURE	NAME	DEFAULT SETTING
1C	NORMAL SOURCE FAILURE TO ENGINE START	1 sec
2B	TRANSFER TO EMERGENCY ON AVAILABILITY OF EMERGENCY SOURCE	0 sec
1F	EMERGENCY SOURCE FAILURE RETRANSFER (NORMAL SOURCE AVAILABLE)	0 sec
2E	ENGINE COOLDOWN FOLLOWING RETRANSFER TO NORMAL	5 min
3A	RETRANSFER TO NORMAL (NORMAL FAILURE MODE)	30 min
3A	RETRANSFER TO NORMAL (TEST MODE)	30 sec
-	DELAYED TRANSFER (LOAD "OFF" TIME), [0-5 min 59 sec]	3 sec

DESCRIPTIONS OF TIME DELAYS:

- FEAT. 1C** - DELAY ON NORMAL SOURCE OUTAGE. STARTS ON FAILURE OF NORMAL SOURCE. RESETS IF NORMAL SOURCE IS ACCEPTED BEFORE EXPIRATION. INHIBITS ENGINE STARTING AND AUTOMATIC TRANSFER UNTIL EXPIRATION.
- FEAT. 2B** - DELAY PRIOR TO TRANSFER TO THE EMERGENCY SOURCE. DELAY STARTS ON EXPIRATION OF FEAT. 1C AND WHEN THE EMERGENCY SOURCE HAS BEEN ACCEPTED. DELAY RESETS IF THE EMERGENCY SOURCE FAILS PRIOR TO EXPIRATION. UPON EXPIRATION, TRANSFER TO EMERGENCY IS INITIATED ON AUTOMATIC UNITS (4ACTS) UNLESS THE NORMAL SOURCE HAS RECOVERED AND THE "COMMIT TO TRANSFER" FEATURE IS SET TO "NO" COMMIT. PROVIDES A PERIOD FOR EMERGENCY SOURCE STABILIZATION OR STAGING OF MULTIPLE TRANSFER SWITCH CONTROLLED LOADS TO THE EMERGENCY SOURCE.
- FEAT. 1F** - DELAY ON RETRANSFER TO NORMAL IN THE EVENT OF EMERGENCY SOURCE FAILURE. DELAY BEGINS ON FAILURE OF THE EMERGENCY SOURCE IF THE NORMAL SOURCE IS ACCEPTABLE. UPON EXPIRATION OF THE DELAY, RETRANSFER TO NORMAL WILL BE INITIATED ON AUTOMATIC UNITS (4ACTS).
- FEAT. 2E** - DELAY ON ENGINE SHUTDOWN (ENGINE COOL DOWN PERIOD). DELAY STARTS FOLLOWING RETRANSFER TO THE NORMAL SOURCE. PROVIDES A PERIOD FOR THE ENGINE-GENERATOR SET TO RUN UNLOADED PRIOR TO SHUTDOWN.
- FEAT. 3A** - RETRANSFER TO NORMAL DELAY (NORMAL FAILURE MODE) DELAY STARTS WHEN NORMAL SOURCE IS ACCEPTED (FOLLOWING IT'S FAILURE) AND WHILE THE LOAD IS CONNECTED TO EMERGENCY. RESETS IF NORMAL FAILS PRIOR TO EXPIRATION OR IF THE EMERGENCY SOURCE FAILS BEFORE EXPIRATION AND FEAT. 1F EXPIRES (AUTOMATIC BYPASS ON EMERGENCY SOURCE FAILURE). PROVIDES A PERIOD FOR THE NORMAL SOURCE TO STABILIZE PRIOR TO AUTOMATIC (4ACTS) OR MANUAL (4NCTS) RETRANSFER.
- FEAT. 3A** - RETRANSFER TO NORMAL DELAY (TEST MODE) DELAY STARTS FOLLOWING A USER INITIATED "TRANSFER TEST" WHEN THE "RETRANSFER TO NORMAL" KEYPAD IS DEPRESSED ON AUTOMATIC UNITS (4ACTS) AND WHILE THE LOAD IS CONNECTED TO EMERGENCY. RESETS IF NORMAL FAILS PRIOR TO EXPIRATION OR IF THE EMERGENCY SOURCE FAILS BEFORE EXPIRATION AND FEAT. 1F EXPIRES (AUTOMATIC BYPASS ON EMERGENCY SOURCE FAILURE).

IN SYNC - IN SYNC TIME DELAY BEGINS BEFORE A CLOSED TRANSITION TRANSFER FOLLOWING ACCEPTANCE OF THE SOURCE TO WHICH TRANSFER IS BEING MADE. ON EXPIRATION OF THE DELAY, THE LOGIC AWAITS AN IN SYNC CONDITION FOR SUBSEQUENT CLOSED TRANSITION TRANSFER.

EXTENDED PARALLEL - EXTENDED PARALLEL TIMER BEGINS WHEN THE SOURCES ARE PARALLELED (CN & CE CLOSED). IF THE TWO SOURCES REMAIN IN PARALLEL WHEN THE DELAY EXPIRES, THE CONTROL LOGIC TAKES THE FOLLOWING ACTIONS:

- THE LOGIC WILL ATTEMPT TO OPERATE THE TRANSFER SWITCH TO A "SAFE" STATE WHERE THE SOURCES WILL NO LONGER BE PARALLELED AND THE LOAD WILL BE SERVICED BY AN AVAILABLE SOURCE.
- THE CONTROL PANEL IS LOCKED OUT FROM ANY FURTHER AUTOMATIC OPERATION.
- THE "TRANSFER SWITCH LOCKED OUT" INDICATOR (RED LED) IS LIT.
- THE UNIT WILL REMAIN LOCKED OUT UNTIL THE "ALARM RESET" KEYPAD IS DEPRESSED FOR RESET.

FAIL TO SYNC - FAILURE TO SYNC TIMER BEGINS WHEN THE LOGIC BEGINS TO CHECK FOR AN IN SYNC CONDITION FOR WHICH TO ALLOW CLOSED TRANSITION TRANSFER. IF THE DELAY EXPIRES PRIOR TO AN IN SYNC CONDITION OCCURRING, THE "FAILURE TO SYNCHRONIZE" INDICATOR IS ACTIVATED (RED LED) WITH CLOSURE OF THE TFR RELAY CONTACT AVAILABLE FOR A REMOTE SIGNAL.

FEAT. 62F - EXTENDED PARALLEL ALARM TIMER BEGINS TIMING WHEN THE SOURCES ARE PARALLELED (CN & CE CLOSED). THE ENABLING OF THE EXTENDED PARALLEL ALARM TIMER OCCURS AT THE SAME TIME THAT THE CONTROLLER'S EXTENDED PARALLEL TIMER BEGINS.

THE FEATURE 62F EXTENDED PARALLEL ALARM TIMER IS INDEPENDENT OF THE CONTROLLER'S EXTENDED PARALLEL TIMER DESCRIBED UNDER "DESCRIPTION OF TIME DELAYS".

ON EXPIRATION OF THE FEATURE 62F EXTENDED PARALLEL ALARM TIME DELAY, OUTPUT RELAY (RL3) (2) FORM C CONTACTS, TRANSFER.

THE FEATURE 62F EXTENDED PARALLEL ALARM DELAY IS ADJUSTABLE VIA POTENTIOMETER (P2) LOCATED ON THE DUAL OPERATOR CONTROL (DOC) WHICH IS ADJUSTABLE FROM 0-1 SECOND. FACTORY SET AT 1 SEC.

NOTE: THE TIMER SHOULD BE SET ABOVE 0.7 SECONDS TO PERMIT THE CONTROLLER TO ATTEMPT TO OPERATE THE TRANSFER SWITCH TO A "SAFE" STATE WHERE THE SOURCES WILL NO LONGER BE PARALLELED. THE TIMER CAN BE SET LOWER TO BE USED TO ISOLATE THE TWO SOURCES WITH AN EXTERNALLY CONTROLLED FEEDER CIRCUIT BREAKER. HOWEVER THE CONTROLLER MAY NOT BE ABLE TO PLACE THE TRANSFER SWITCH IN A "SAFE" STATE.

ENGINE EXERCISER

THE ENGINE EXERCISER FEATURE PROVIDES A MEANS TO PERFORM AUTOMATIC EXERCISING OF THE ENGINE-GENERATOR SET EITHER WITH OR WITHOUT LOAD TRANSFER FOR AUTOMATIC UNITS (4ACTS) OR WITHOUT LOAD TRANSFER FOR NON-AUTOMATIC UNITS (4NCTS).

- THE USER CAN PROGRAM UP TO SEVEN DIFFERENT EXERCISE ROUTINES. EACH ROUTINE INCLUDES:
1. ENABLE OR DISABLE THE ROUTINE
 2. ENABLE OR DISABLE TRANSFER OF THE LOAD DURING THE ROUTINE
 3. SET START TIME OF ROUTINE -
 - TIME OF DAY
 - DAY OF WEEK
 - WEEK OF MONTH (1st, 2nd, 3rd, 4th, ALTERNATE OR ALL)
 4. SET THE DURATION OF THE ROUTINE

PARAMETER	RANGE OF SETTING	DEFAULT SETTING
MONTH (CLOCK SET)	JAN FEB MAR APR MAY JUN JUL AUG SEP OCT NOV DEC	CURRENT DATE
DAY	1-31	Eastern Standard Time
YEAR	00-99	0
HOUR	0-23	0
MINUTE	0-59	0
ENABLE ROUTINE (ROUTINE 1-7)	YES/NO	NO
TRANSFER LOAD	YES/NO	NO
START HOUR	0-23	0
START MINUTE	0-59	0
RUN WEEK	ALL, ALTERNATE, 1st, 2nd, 3rd, 4th, 5th	ALL
RUN DAY	SUN MON TUE WED THU FRI SAT	SUN
DURATION HOURS	0-23	0
DURATION MINUTES	0-59	0

OPERATION

IF THE NORMAL SOURCE FAILS, THE TRANSFER SWITCH INITIATES STARTING OF THE ENGINE-GENERATOR SET. WHEN PROPER VOLTAGE AND FREQUENCY HAVE BEEN ATTAINED, THE LOAD WILL BE TRANSFERRED ON AUTOMATIC UNITS (4ACTS) OR PERMITTED TO BE MANUALLY TRANSFERRED NON-AUTOMATIC UNITS (4NCTS) IN AN OPEN TRANSITION (BREAK BEFORE MAKE) OPERATION TO THE EMERGENCY SOURCE.

WHEN THE NORMAL SOURCE IS RESTORED FOR THE DURATION OF THE FEATURE 3A, (RETRANSFER TO NORMAL TIME DELAY) SETTING, AND FOLLOWING OPERATION OF THE "TRANSFER TO NORMAL" KEYPAD ON NON-AUTOMATIC UNITS (4NCTS), THE CONTROLS WILL BEGIN MONITORING PHASE, FREQUENCY, AND VOLTAGE DIFFERENTIAL BETWEEN NORMAL AND EMERGENCY SOURCES.

WHEN THE TWO SOURCES ARE APPROACHING SYNCHRONISM, A CLOSED TRANSITION (MAKE BEFORE BREAK) TRANSFER TO THE NORMAL SOURCE WILL BE INITIATED. THE NORMAL AND EMERGENCY CONTACTORS (CN & CE) WILL BE IN AN OVERLAP CONDITION FOR LESS THAN 0.1 SECONDS.

CLOSED TRANSITION TRANSFER WILL ALSO BE INITIATED DURING A TRANSFER TEST OPERATION INITIATED BY OPERATION OF THE FEATURE 5 "TRANSFER TEST" KEYPAD ON AUTOMATIC UNITS (4ACTS) OR AFTER OPERATION OF THE "TRANSFER TO EMERGENCY" KEYPAD ON NON-AUTOMATIC UNITS (4NCTS). RETRANSFER WILL ALSO OCCUR IN A CLOSED TRANSITION MANNER AT THE END OF THE TEST ON AUTOMATIC UNITS (4ACTS) OR ACTIVATION OF THE TRANSFER TO NORMAL KEYPAD ON NON-AUTOMATIC UNITS (4NCTS).

CLOSED TRANSITION BYPASS OPERATION: THE "CT BYPASS OPTIONS" DISPLAY OF THE CONTROL PANEL ALLOWS SETTING THE TRANSFER SWITCH'S CLOSED TRANSITION BYPASS BEHAVIOR. CLOSED TRANSITION BYPASS CAUSES THE TRANSFER SWITCH TO INTERRUPT POWER TO THE LOAD DURING TRANSFER. THE AVAILABLE OPTIONS ARE:

- **FAIL TO SYNC AUTO BYPASS ENABLE** - CAUSES A "FAILURE TO SYNCHRONIZE" CONDITION TO RESULT IN A CLOSED TRANSITION BYPASS. DEFAULT SETTING IS NO AUTOMATIC BYPASS.
- **CT BYPASS** - ALLOWS SELECTIONS AS TO WHETHER THE CLOSED TRANSITION BYPASS WILL OCCUR WITH OR WITHOUT A DELAYED TRANSITION (LOAD "OFF" TIME). DEFAULT SETTING IS OPEN TRANSITION (NO DELAY). OPERATION CONTINUE.....

BASE CATALOG NUMBER				CATALOG NUMBER SUFFIXES				EXPLANATION OF CATALOG NUMBER CODES															
TS	CATALOG	NEUTRAL	PHASE	AMPS	VOLT	CONTROLLER	OPTIONAL	ENCLOSURE	CATALOG TYPE		NEUTRAL TYPE		VOLTAGE CODES		ENCLOSURE CODES								
FRAME	TYPE	TYPE	POLES		CODE		ACCESSORY	CODE	CODE	DESC.	CODE	DESCRIPTION	CODE	NOMINAL VOLTAGE	CODE	TYPE	DESCRIPTION						
	4ACTS	A	3	600	H	5	X	C	4ACTS	AUTOMATIC	BLANK	NONE	D	208	BLANK	1	OPEN TYPE (NO ENCLOSURE)						
	4NCTS	B		800	J			E	4NCTS	MANUAL	A	SOLID SWITCHING	E	230	E	2	GENERAL PURPOSE, INDOOR						
				1000	K			F			B		F	240	F	3R	INDOOR, WATER & DUST RESISTANT						
				1200	L			G			C		H	380	G	4	OUTDOOR, RAINPROOF, SLEET & ICE RESISTANT						
					M			H			D		J	400	H	4X	INDOOR/OUTDOOR, WATERTIGHT & DUST TIGHT						
					N			I			E		K	415	J	4X	TYPE 4 PLUS CORROSION RESISTANCE (STAINLESS STEEL)						
					O			J			F		L	440	K	7	TYPE 4 PLUS CORROSION RESISTANCE (FIBERGLASS)						
					P			K			G		M	460	L	12	EXPLOSION PROOF						
					Q			L			H		N	480			INDOOR, INDUSTRIAL ENVIRONMENTS, OIL TIGHT & DUST TIGHT						
					R			M			I		O	550	M	3R	(SECURE ENCLOSURES)						
								N			J		P	575	N	4	OUTDOOR, RAINPROOF, SLEET & ICE RESISTANT						
								O			K		Q	600	P	4X	INDOOR/OUTDOOR, WATERTIGHT & DUSTTIGHT						
								P			L				Q	12	TYPE 4 PLUS CORROSION RESISTANCE (STAINLESS STEEL)						
								Q			M						INDOOR, INDUSTRIAL ENVIRONMENTS, OILTIGHT & DUSTTIGHT						
											NONE												

• **DT BYPASS** - SETS THE LENGTH OF THE DELAYED TRANSFER (LOAD "OFF" TIME) IF THE PREVIOUS PARAMETER HAS BEEN SELECTED TO OPERATE WITH DELAYED TRANSITION. THE DELAY ("OFF" PERIOD) BEGINS FOLLOWING THE OPENING OF THE SOURCE CONTACTOR, (CN OR CE), CONNECTED TO THE SOURCE FROM WHICH TRANSFER IS BEING MADE. UPON EXPIRATION, CLOSURE OF THE OPPOSITE SOURCE CONTACTOR IS INITIATED.

SIGNALS & AUXILIARIES

A. FEATURES 7 & 8- ENGINE START SIGNAL
SIGNAL INITIATED BY DROPOUT OF CONTROL PANEL RELAY (NR) FOLLOWING EXPIRATION OF THE FEATURE 1C TIME DELAY (DELAY TO OVERRIDE MOMENTARY NORMAL SOURCE OUTAGES). THE 1C DELAY IS BYPASSED ON NON-AUTOMATIC UNITS (4NCTS) WHEN TRANSFER IS INITIATED BY OPERATION OF THE "TRANSFER TO NORMAL" KEYPAD AND THE NORMAL SOURCE IS AVAILABLE. FEATURE 7 CLOSURES TO SIGNAL ENGINE START. FEATURE 8 OPENS TO SIGNAL ENGINE START. ENGINE STARTING SIGNAL RESETS FOLLOWING RETRANSFER TO THE NORMAL SOURCE AND EXPIRATION OF THE FEATURE 2E (ENGINE COOL DOWN) TIME DELAY. FEATURES 7 & 8 ARE PROVIDED AS A SINGLE FORM C CONTACT CONNECTED TO THE FIELD CONNECTIONS TERMINAL BLOCK (TB) MOUNTED ON THE UPPER RIGHT SIDE OF THE ENCLOSURE. CONTACT RATED 5 AMPS AT 32 VDC/120VAC RESISTIVE.

B. FEATURES 14AA & 14BA - TRANSFER SWITCH AUXILIARY POSITION INDICATING CONTACTS. TWO (2) FORM A CONTACTS EACH TO INDICATE CONNECTION OF THE TRANSFER SWITCH TO NORMAL (14A) OR EMERGENCY (14B). CONTACTS CONNECTED TO THE FIELD CONNECTIONS TERMINAL BLOCK (TB) MOUNTED ON THE UPPER RIGHT SIDE OF THE ENCLOSURE. CONTACTS RATED 10 AMPS, 32 VDC, 250 VAC.

C. FEATURE 17 - REMOTE TRANSFER TO EMERGENCY. REQUIRES A CUSTOMER SUPPLIED NORMALLY OPEN CONTACT. CLOSING OF THE CONTACT CAUSES ENGINE START AND TRANSFER TO THE EMERGENCY SOURCE ON AUTOMATIC UNITS (4ACTS). OPENING OF THE CONTACT ACTIVATES THE FEATURE 3A (RETRANSFER TO NORMAL) DELAY PRIOR TO RETRANSFER. IN THE EVENT THE EMERGENCY SOURCE FAILS WHILE THE TRANSFER SWITCH IS CONNECTED TO EMERGENCY AND THE REMOTE CONTACT IS CLOSED, THE TRANSFER SWITCH WILL RETRANSFER TO THE NORMAL SOURCE. LOCATED ON TERMINAL BLOCK TB1 ON THE REAR OF THE OPERATOR INTERFACE MODULE ON THE FRONT DOOR.

USER CONTROLS AND INDICATIONS

A. FEATURES 5 & 6B - "TRANSFER TEST" & "RETRANSFER TO NORMAL" KEYPAD CONTROLS. STANDARD ON AUTOMATIC UNITS (4ACTS).

"TRANSFER TEST" KEYPAD: OPERATION CAUSES A NORMAL SOURCE FAILURE SEQUENCE. ACTIVATE AND HOLD FOR AT LEAST 15 SECONDS TO ALLOW TIME FOR THE ENGINE-GENERATOR TO START.

"RETRANSFER TO NORMAL" KEYPAD: OPERATION WILL BYPASS THE FEATURE 3A (RETRANSFER TO NORMAL DELAY) INITIATING RETRANSFER TO THE NORMAL SOURCE.

FEATURE 6Z & 6C - MANUAL TRANSFER CONTROL, "TRANSFER TO EMERGENCY" & "TRANSFER TO NORMAL" KEYPAD CONTROLS. STANDARD ON NON-AUTOMATIC UNITS (4NCTS).

"TRANSFER TO EMERGENCY" KEYPAD: OPERATION CAUSES IMMEDIATE ENGINE START IF NORMAL IS AVAILABLE AND TRANSFER TO THE EMERGENCY SOURCE WHEN THE EMERGENCY SOURCE IS AVAILABLE. TRANSFER SWITCH WILL REMAIN CONNECTED TO THE EMERGENCY SOURCE UNTIL THE UNIT IS MANUALLY RETRANSFERRED TO THE NORMAL SOURCE.

"TRANSFER TO NORMAL" KEYPAD: OPERATION CAUSES TRANSFER TO THE NORMAL SOURCE IF IT IS AVAILABLE. THE ENGINE START SIGNAL WILL RUN FOR THE ACCESSORY 2E DELAY ON ENGINE SHUTDOWN FOLLOWING TRANSFER. THE TRANSFER SWITCH WILL REMAIN CONNECTED TO THE NORMAL SOURCE UNTIL THE UNIT IS MANUALLY TRANSFERRED TO THE EMERGENCY SOURCE.

B. FEATURES 9A & 9B - TRANSFER SWITCH POSITION INDICATORS.
FEATURE 9A: TRANSFER SWITCH CLOSED ON NORMAL (GREEN LED)
FEATURE 9B: TRANSFER SWITCH CLOSED ON EMERGENCY (RED LED)

C. FEATURES 9C & 9D - SOURCE ACCEPTANCE INDICATORS.
FEATURE 9C: NORMAL SOURCE ACCEPTED (GREEN LED)
FEATURE 9D: EMERGENCY SOURCE ACCEPTED (RED LED)

D. "EXTENDED PARALLEL TIME" INDICATOR - INDICATES THAT THE MAIN CONTACTORS (CN & CE) HAVE BEEN SIMULTANEOUSLY CLOSED FOR A PERIOD EXCEEDING THE TIME ALLOTTED. (RED LED)

E. "FAILURE TO SYNCHRONIZE" INDICATOR - INDICATES THE THE TWO SOURCES DID NOT MEET THE PARAMETERS REQUIRED FOR A CLOSED TRANSITION TRANSFER. (RED LED)

F. "TRANSFER SWITCH LOCKED OUT" INDICATOR - INDICATES THAT A FAILURE OF THE TRANSFER SWITCH OPERATOR HAS OCCURRED AND THAT THE TRANSFER SWITCH HAS TAKEN CORRECTIVE ACTION AS REQUIRED. ONCE THIS FAILURE RECOVERY OPERATION TAKES PLACE, THE TRANSFER SWITCH IS PREVENTED FROM FURTHER OPERATION UNTIL THE CONDITION IS CORRECTED. ONCE THE CONDITION IS CORRECTED, THE TS LOCKED OUT SWITCH MAY BE DEPRESSED TO RESET THE CONTROL PANEL (RED LED).

G. "ALARM RESET" KEYPAD - ONCE A LOCK OUT CONDITION IS CORRECTED, THE "ALARM RESET" KEYPAD MAY BE ACTUATED TO RESET THE CONTROL PANEL. THIS CONTROL ALSO RESETS THE "FAILURE TO SYNCHRONIZE" AND "EXTENDED PARALLEL TIME" ALARMS.

H. "CLOSED TRANSITION BYPASS" KEYPAD - BYPASSES CLOSED TRANSITION TRANSFER WHEN ACTUATED DURING THE PERIOD WHILE THE TRANSFER SWITCH CONTROL PANEL IS MONITORING FOR AN INPHASE CONDITION. CAUSES OPEN TRANSITION TRANSFER TO THE OPPOSITE SOURCE IF CONDITIONS PERMIT.

OPTIONAL ACCESSORIES

A. ACCESSORY 14AC & 14BC - TWO (2) ADDITIONAL TRANSFER SWITCH AUXILIARY POSITION INDICATING CONTACTS EACH TO INDICATE CONNECTION OF THE TRANSFER SWITCH TO NORMAL (14A) OR EMERGENCY (14B). CONTACTS CONNECTED TO THE FIELD CONNECTIONS TERMINAL BLOCK (TB) MOUNTED ON THE UPPER RIGHT SIDE OF THE ENCLOSURE. CONTACTS RATED 10 AMPS, 32 VDC, 250 VAC.

B. ACCESSORY 18Z & 18Z2 - OPTION RELAY MODULE. PROVIDES A RELAY MODULE ASSEMBLY THAT CONNECTS TO THE REAR OF THE USER INTERFACE MODULE. ACCESSORY 18Z PROVIDES ONE (1) RELAY MODULE & ACCESSORY 18Z2 PROVIDES TWO (2) RELAY MODULES.

EACH RELAY MODULE PROVIDES 4 INDEPENDENT, FORM C RELAY OUTPUTS EACH RATED 2 AMPS, 30 VDC MAX. THE RELAY PROVIDE THE FOLLOWING SIGNALS:

RELAY 1 (RL1) ENERGIZES IF THE EMERGENCY SOURCE HAS BEEN ACCEPTED BY THE CONTROLLER.

RELAY 2 (RL2) ENERGIZES IF THE NORMAL SOURCE HAS BEEN ACCEPTED BY THE CONTROLLER.

RELAY 3 (RL3) ENERGIZES IF THE CONTROLLER'S LOAD DISCONNECT SIGNAL IS ACTIVE. (FEATURE 31, REFER TO THE GROUP 5 CONTROLLER USER'S MANUAL, PN 381333-126).

RELAY 4 (RL4) USER CONFIGURED OUTPUT THAT CAN BE USER DEFINED TO OPERATE AS FOLLOWS:

- SAME AS RELAY 1.
- SAME AS RELAY 2.
- ENERGIZES IF "EXTENDED PARALLEL TIME" INDICATOR IS ON.
- ENERGIZES IF "TRANSFER SWITCH LOCKED OUT" INDICATOR IS ON.
- ENERGIZES IF "FAILURE TO SYNCHRONIZE" INDICATOR IS ON.
- ENERGIZES IF "EXTENDED PARALLEL TIME" OR "TRANSFER SWITCH LOCKED OUT" OR "FAILURE TO SYNCHRONIZE" INDICATORS ARE ON.
- DE-ENERGIZES IF BOTH SOURCES ARE UNACCEPTABLE AND PROVIDES ONBOARD JUMPER TO PERMIT THE RELAY TO BE USED TO ALLOW AN EXTERNAL 24 VDC SOURCE TO POWER THE CONTROLLER FOR EXTENDED ENGINE STARTING TIME DELAY SETTINGS WHEN POWER IS NOT AVAILABLE.

REFER TO INSTRUCTION SHEET PN 381339-260 FOR INSTRUCTIONS.

GENERAL NOTES

1. SWITCH SHOWN DE-ENERGIZED AND CONNECTED TO THE NORMAL SOURCE.
2. DEVICE SYMBOLS AND DESIGNATIONS ARE IN ACCORDANCE WITH NEMA PUBLICATION ICS 1-1983, PART 1-101A.
3. ALL WIRING IS #16 AWG, TINNED, STRANDED COPPER UNLESS OTHERWISE INDICATED.
4. O ON TERMINAL BLOCKS INDICATES AVAILABLE FIELD CONNECTION POINT.
5. ● ON TERMINAL BLOCKS INDICATES FACTORY CONNECTION POINT.
6. CONTROL AND ACCESSORY WIRING IS ROUTED IN ACCORDANCE WITH ASCO ASSEMBLY PROCEDURE GS451261.
7. AN OPERATOR'S MANUAL IS FURNISHED WITH EACH AUTOMATIC TRANSFER SWITCH. REFER TO THIS PUBLICATION PRIOR TO INSTALLATION AND OPERATION OF THE UNIT.

CATALOG NUMBER _____

ASCO® CERTIFIED TO

S.O. _____

BY _____

DATE _____

FORM REV E

PROJECT NAME: _____

WIRING _____

DIAGRAM _____

4000 SERIES (H4A/NCTS)3PH 600-1200 AMPS

"H" FRAME, GROUP 5 CONTROLS

MANUFACTURING TOLERANCES TO BE IN ACCORDANCE WITH ASCO PROCEDURE MP-1-003. FOR PLASTIC PARTS SEE MP-1-005.

PROPERTY OF ASCO POWER TECHNOLOGIES. USE PERMITTED FOR OUR WORK ONLY. ALL RIGHTS OF DESIGN OR INVENTION ARE RESERVED.

SCALE: NONE SIZE DS

766510

ASCO® ASCO POWER TECHNOLOGIES, L.P. FLORHAM PARK, NEW JERSEY 07932 U.S.A.

DRAWING E ECN NO. 236871 SHEET 1 OF 6

E	236871	TR	BK	04/30/12
				SEE ECN
D	205825	JPB	JPB	9/8/05

FIELD CONNECTIONS

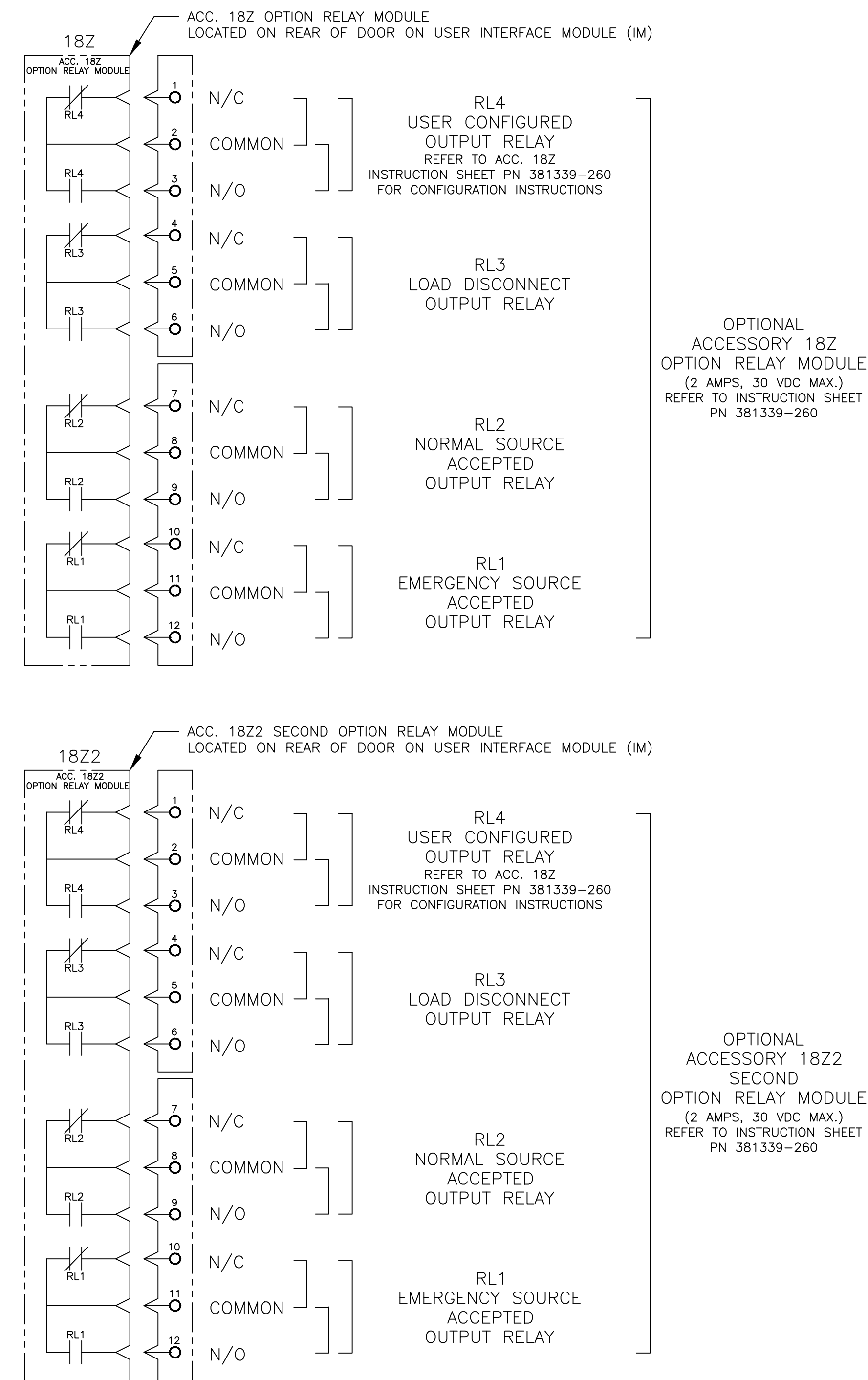
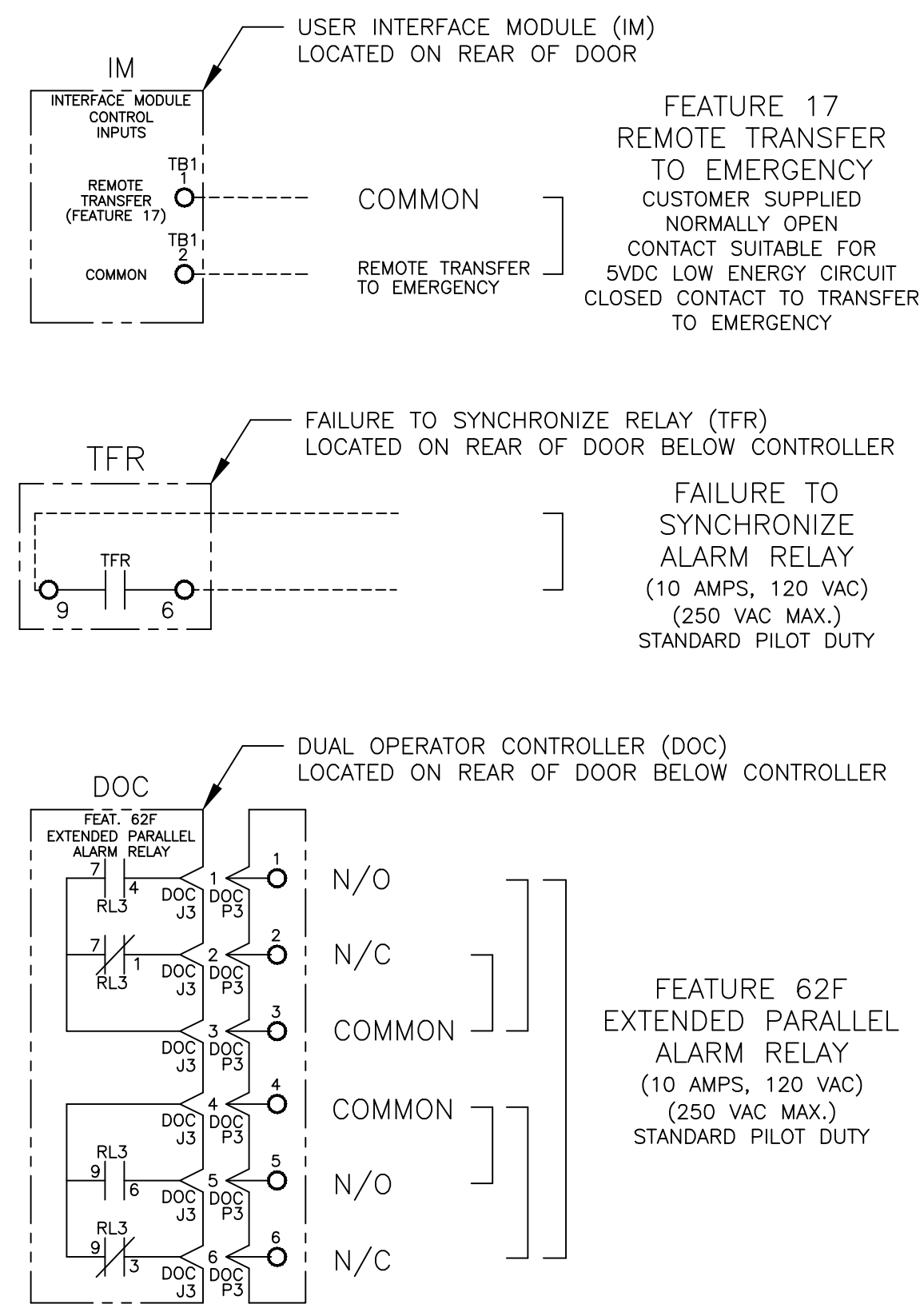
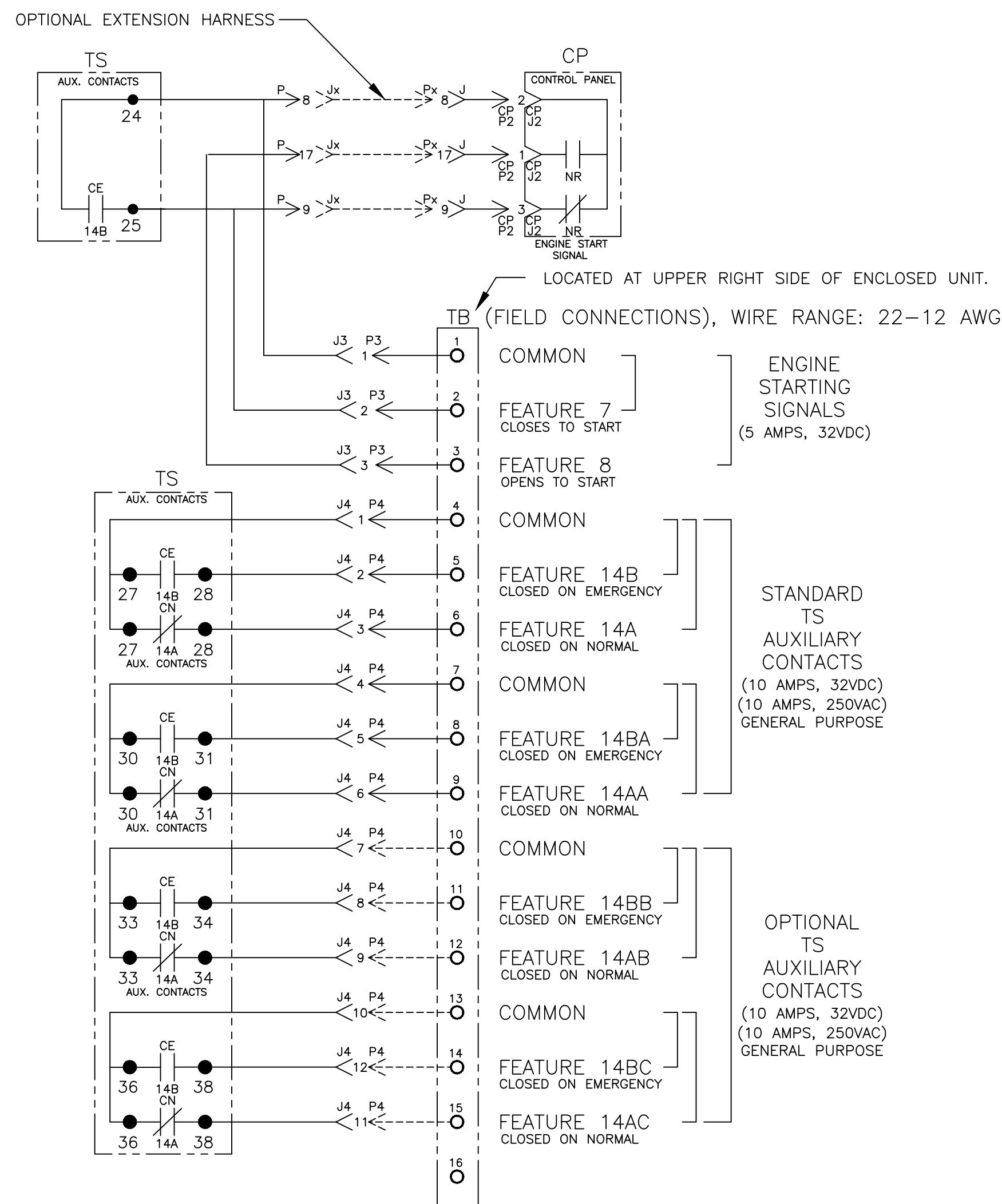

E		236871	TR	BK	04/30/12
REV. TO SHEET	ECN NO.	BY	APP.	DATE	
PROJECT NAME:		WIRING DIAGRAM			
4000 SERIES (H4A/NCTS)3PH 600-1200 AMPS					
"H" FRAME, GROUP 5 CONTROLS					
DRAWN BY	DATE	MANUFACTURING TOLERANCES TO BE IN ACCORDANCE WITH ASCO PROCEDURE MP-1-003. FOR PLASTIC PARTS SEE MP-1-005.	ASSEM. REF. NO.	COMPUTER GENERATED DRAWING	
CHECKED		PROPERTY OF ASCO POWER TECHNOLOGIES. USE PERMITTED FOR OUR WORK ONLY. ALL RIGHTS OF DESIGN OR INVENTION ARE RESERVED.		SCALE	SIZE DS
PROJECT APPROVAL				DWG. NO.	
FINAL APPROVAL	SDH	11/04		766510	
DRAWING E		ASCO POWER TECHNOLOGIES, L.P.		ECN NO.	236871
		FLORHAM PARK, NEW JERSEY 07932 U.S.A.		SHEET	2 OF 6

MAIN POWER POLES

TS OPERATOR CIRCUIT

EMERGENCY

NORMAL

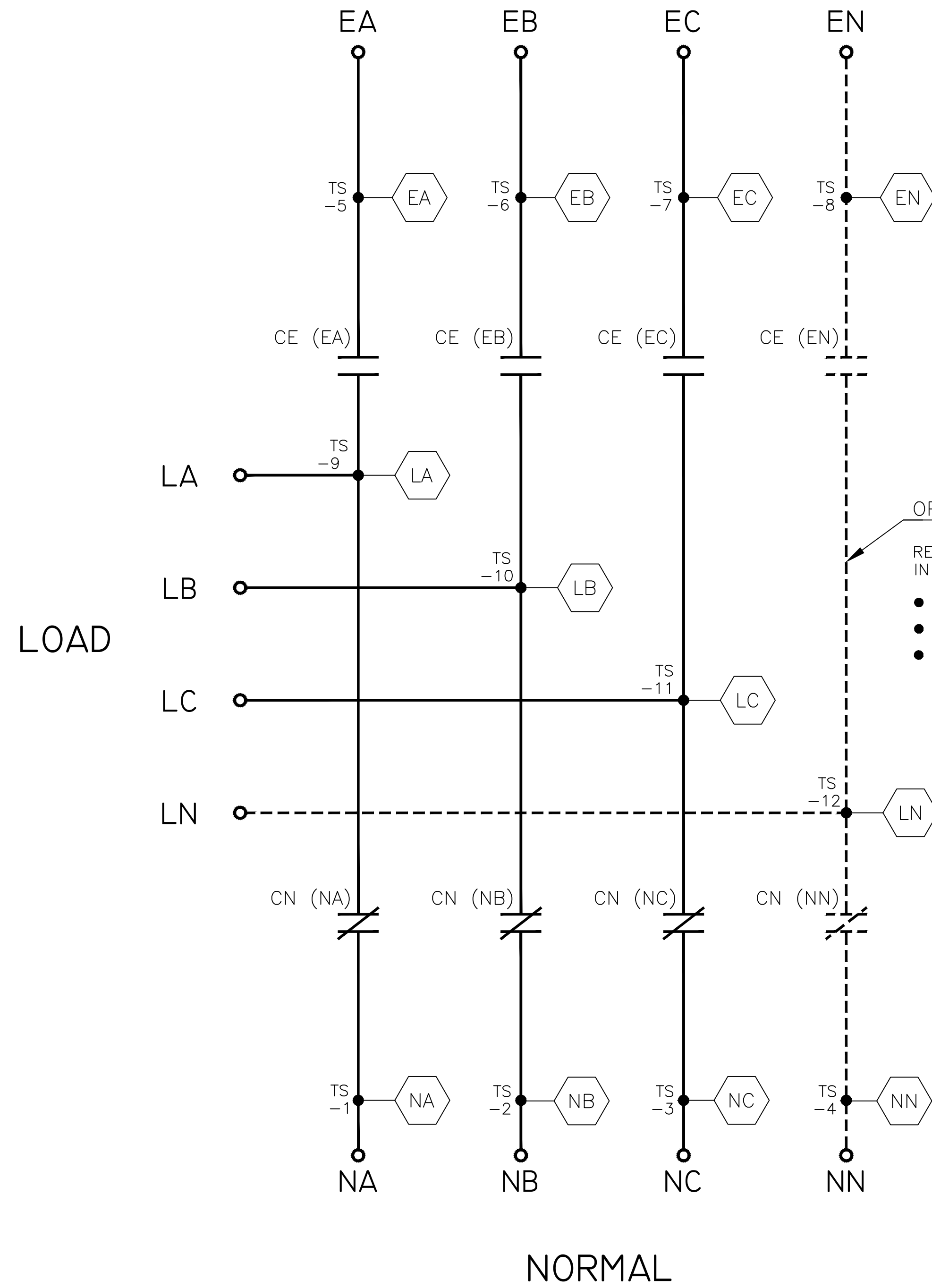

OPTIONAL NEUTRAL TYPES
 REFER TO "EXPLANATION OF CATALOG NUMBER CODES" IN CATALOG NUMBER CHART ON SHEET 1.

- NONE
- SWITCHING
- SOLID BUS PLATE

NOTE:
 ATS SHOWN CLOSED ON NORMAL SOURCE.

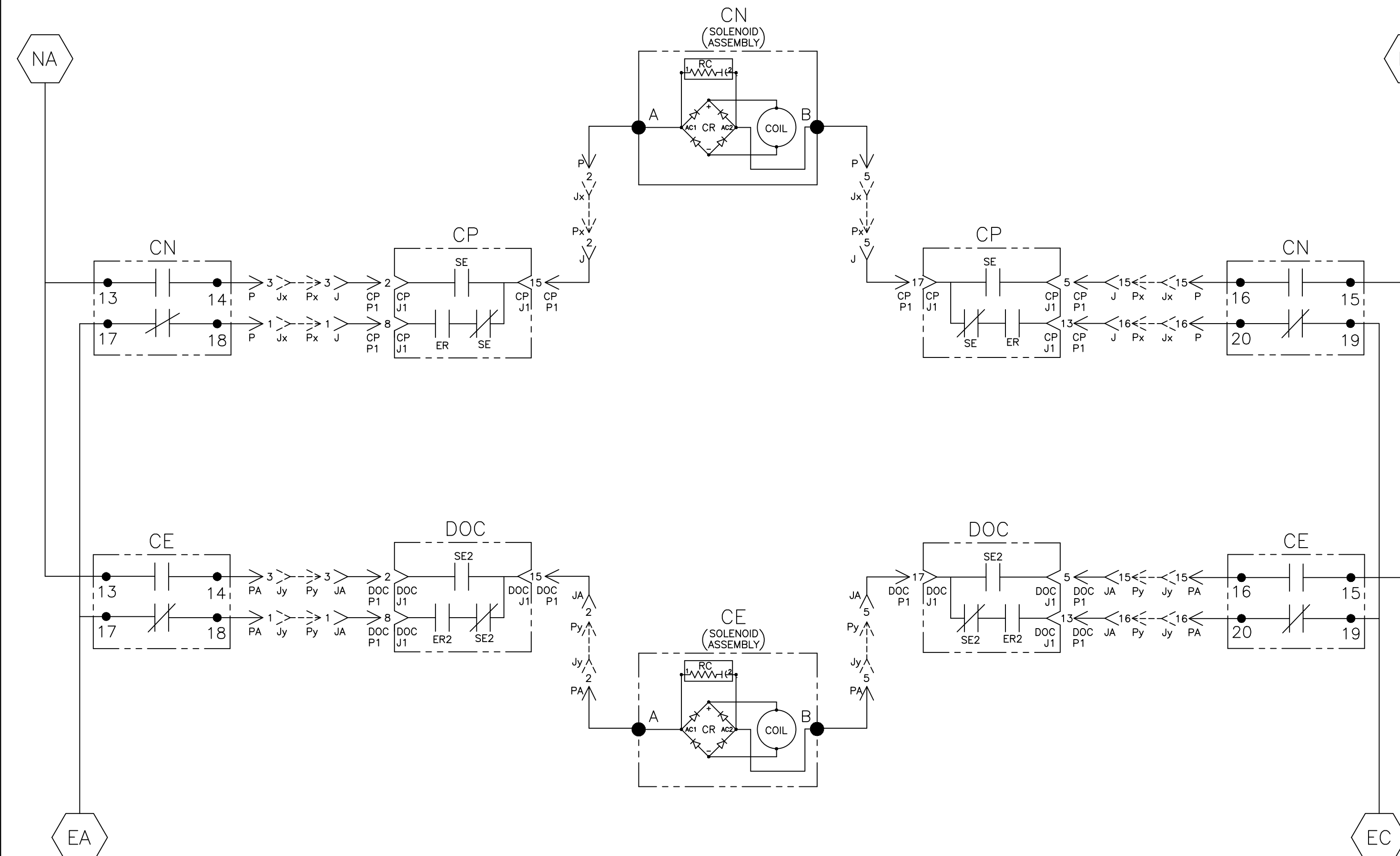

CN CONTROL CONTACTS		SOLENOID POSITION	
CN	CLOSED BEFORE NORMAL TDC*	>	<
13-14			
15-16			
17-18			
19-20			

CE CONTROL CONTACTS		SOLENOID POSITION	
CE	OPEN BEFORE TDC*	>	<
13-14			
15-16			
17-18			
19-20			

TDC (TOP DEAD CENTER)
 TRANSFER SWITCH TEST & ADJUSTMENT PROCEDURE SPECIFIES CONTROL CUT-OFF (CONTACT OPENING) SETTING.

PROJECT NAME:		REV. TO SHEET	ECN NO.	BY	APP.	DATE
WIRING DIAGRAM		236871	TR	BK	04/30/12	
4000 SERIES (H4A/NCTS)3PH 600-1200 AMPS		SEE ECN		THIRD ANGLE PROJECTION		
"H" FRAME, GROUP 5 CONTROLS		COMPUTER GENERATED DRAWING		SCALE NONE SIZE DS		
DRAWN BY	DATE	MANUFACTURING TOLERANCES TO BE IN ACCORDANCE WITH ASCO PROCEDURE MP-1-003. FOR PLASTIC PARTS SEE MP-1-035		DWG. NO.		
SDH	11/04	ASSEM. REF. NO.		766510		
CHECKED		PROPERTY OF ASCO POWER TECHNOLOGIES. USE PERMITTED FOR OUR WORK ONLY. ALL RIGHTS OF DESIGN OR INVENTION ARE RESERVED.		DRAWING E		
PROJECT APPROVAL		SDH		ECN NO. 236871		
FINAL APPROVAL	SDH	11/04		SHEET 3 OF 6		

ASCO Power Technologies, L.P.
 FLORHAM PARK, NEW JERSEY 07932 U.S.A.

EMERGENCY SOURCE CIRCUITS

ADDITIONAL CIRCUITS

EMERGENCY

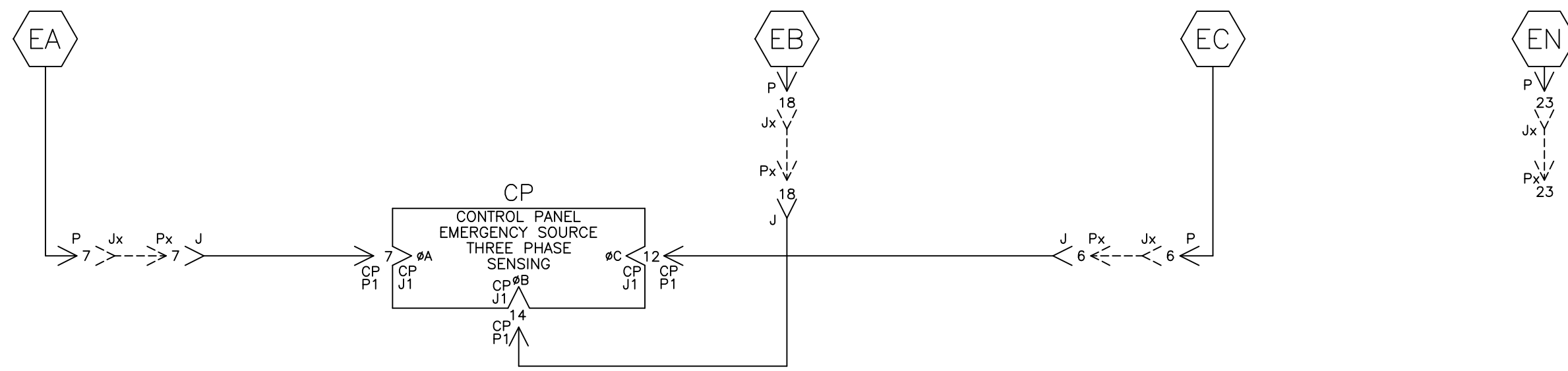

LOAD TERMINAL CIRCUITS

LOAD



NORMAL SOURCE CIRCUITS

NORMAL

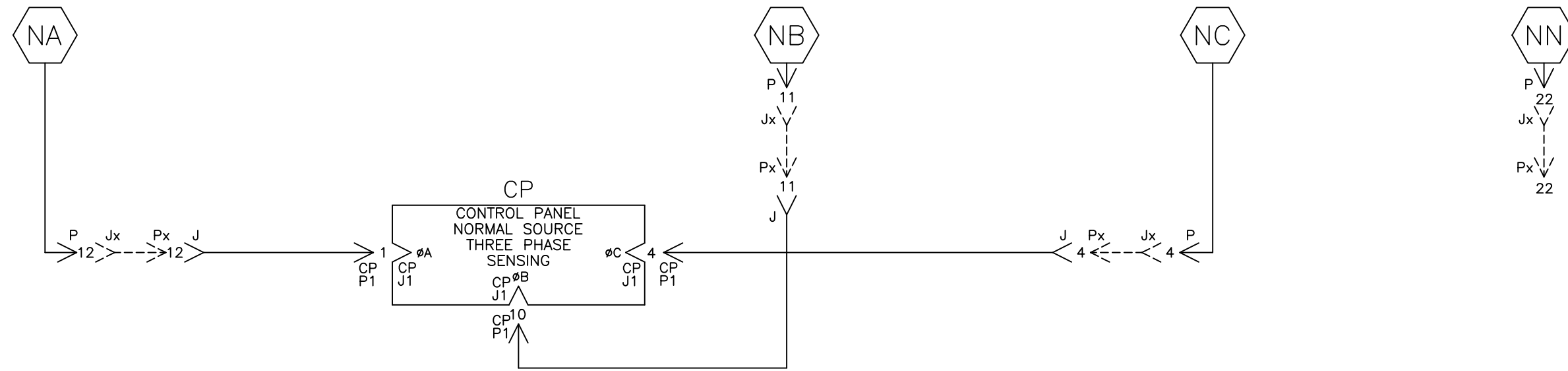

CONTROL CIRCUITS

SER2/ER2 CONTROL

TS POSITION SENSING

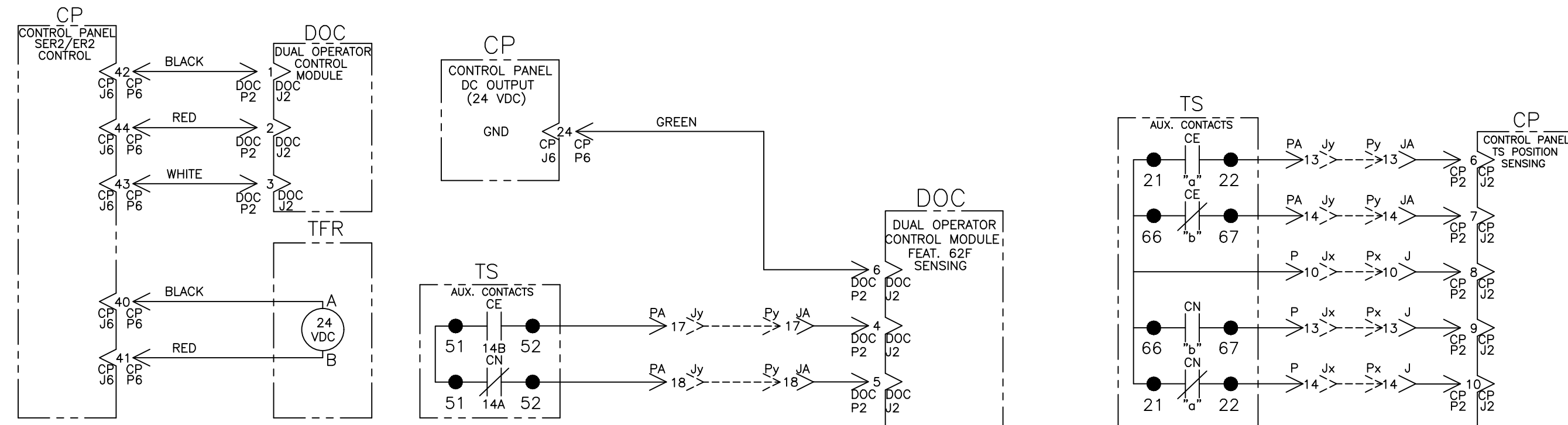

PROJECT NAME:		E 236871 TR BK 04/30/12	
REV TO SHEET	ECN NO.	BY	APP. DATE
WIRING DIAGRAM		COMPUTER GENERATED DRAWING	
4000 SERIES (H4A/NCTS)3PH 600-1200 AMPS			
"H" FRAME, GROUP 5 CONTROLS			
DRAWN BY	DATE	MANUFACTURING TOLERANCES TO BE IN ACCORDANCE WITH ASCO PROCEDURE MP-1-003. FOR PLASTIC PARTS SEE MP-1-005.	ASSEM. REF. NO.
CHECKED	11/04	PROPERTY OF ASCO POWER TECHNOLOGIES. USE PERMITTED FOR OUR WORK ONLY. ALL RIGHTS OF DESIGN OR INVENTION ARE RESERVED.	SCALE NONE SIZE DS
PROJECT APPROVAL			DWG. NO. 766510
FINAL APPROVAL	SDH 11/04	ASCO® ASCO POWER TECHNOLOGIES, L.P. FLORHAM PARK, NEW JERSEY 07932 U.S.A.	DRAWING E ECN NO. 236871 SHEET 4 OF 6

PHYSICAL DIAGRAM

ENCLOSURE

DOOR (INSIDE)

TS (TRANSFER SWITCH)
VIEW FROM INSIDE FRONT

STANDARD:
EMERGENCY & LOAD OUT
OF THE TOP AND NORMAL
OUT THE BOTTOM.

OPTIONAL:
EMERGENCY OUT OF THE TOP
AND NORMAL & LOAD
OUT THE BOTTOM.

DOOR HINGE

BONDING STRAP
PN 098323-019

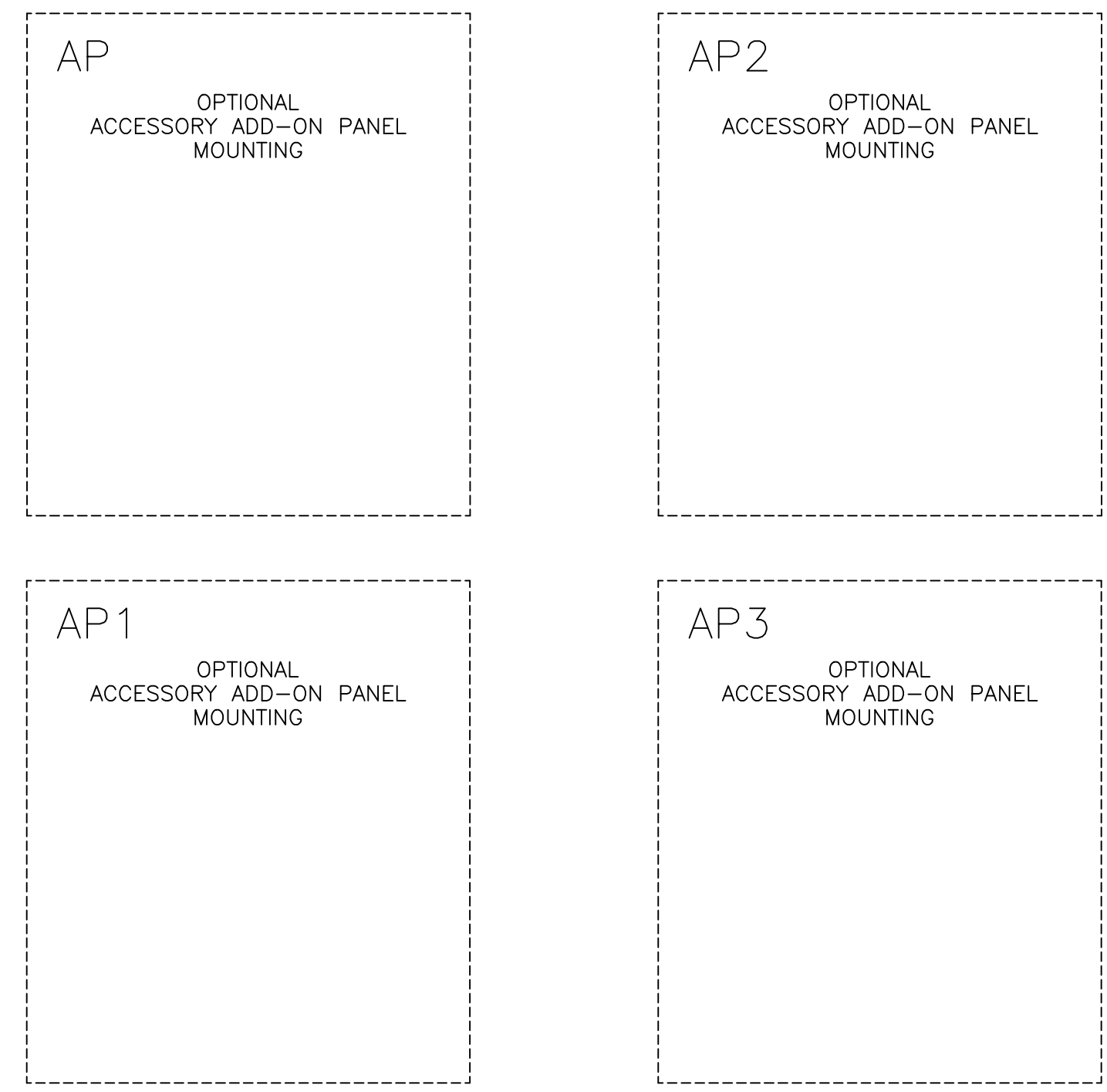
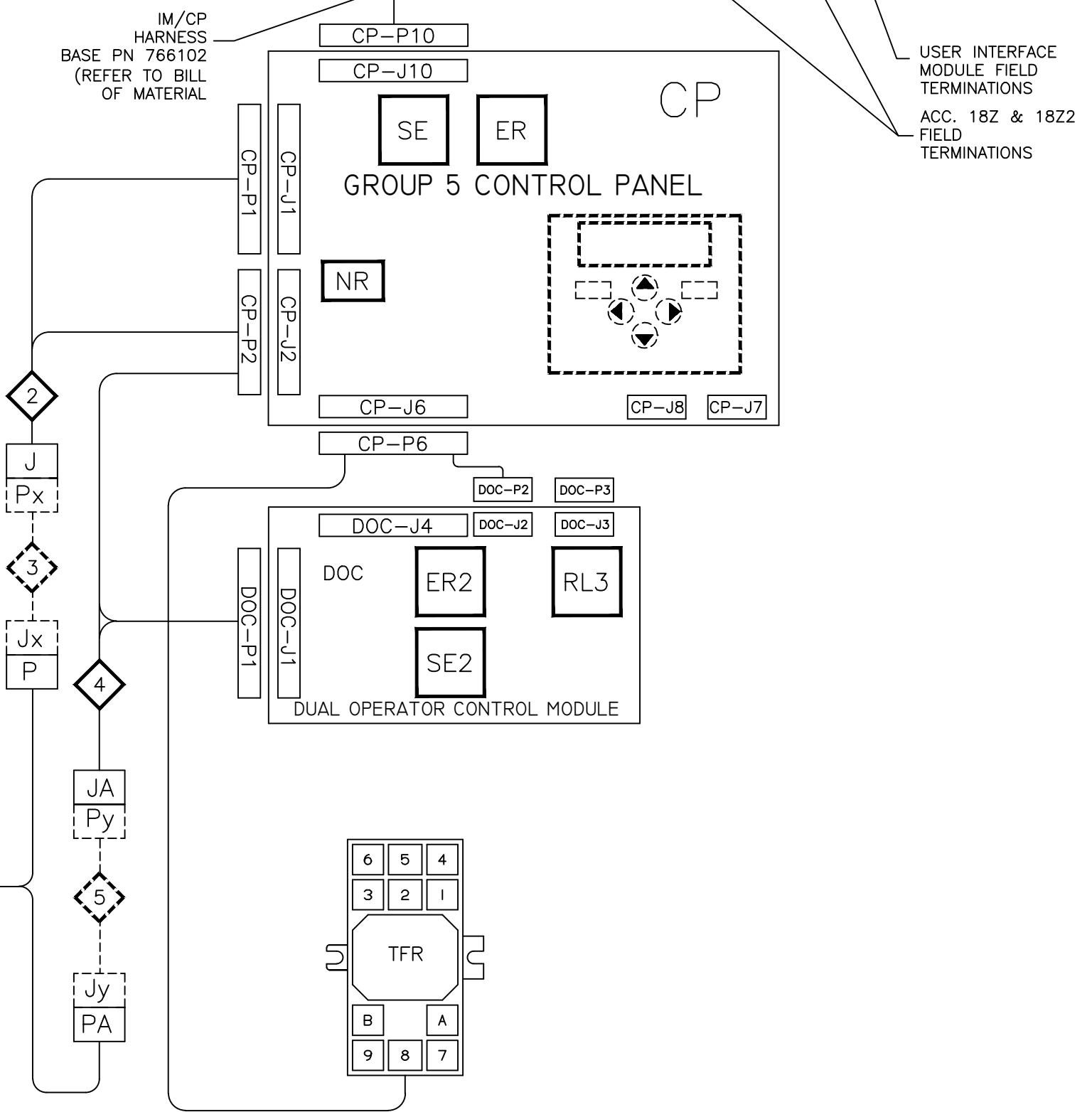
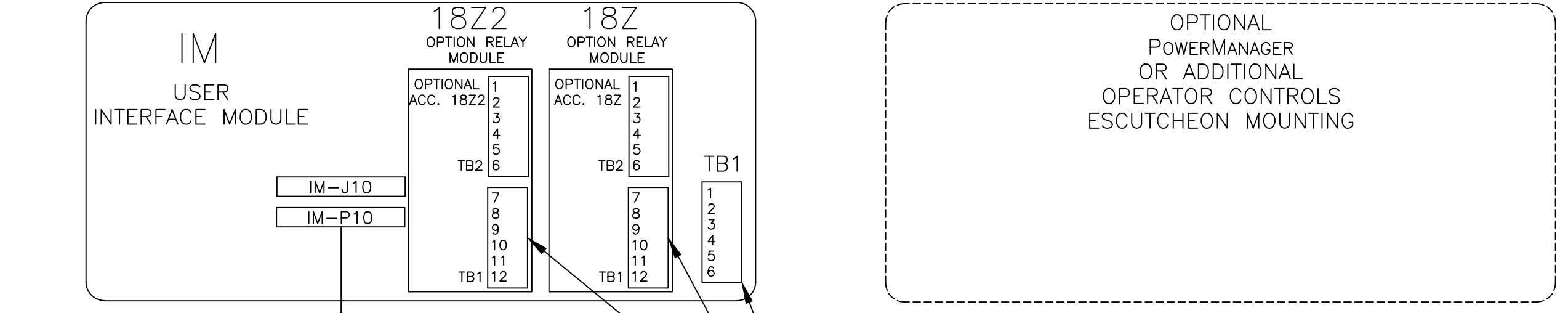
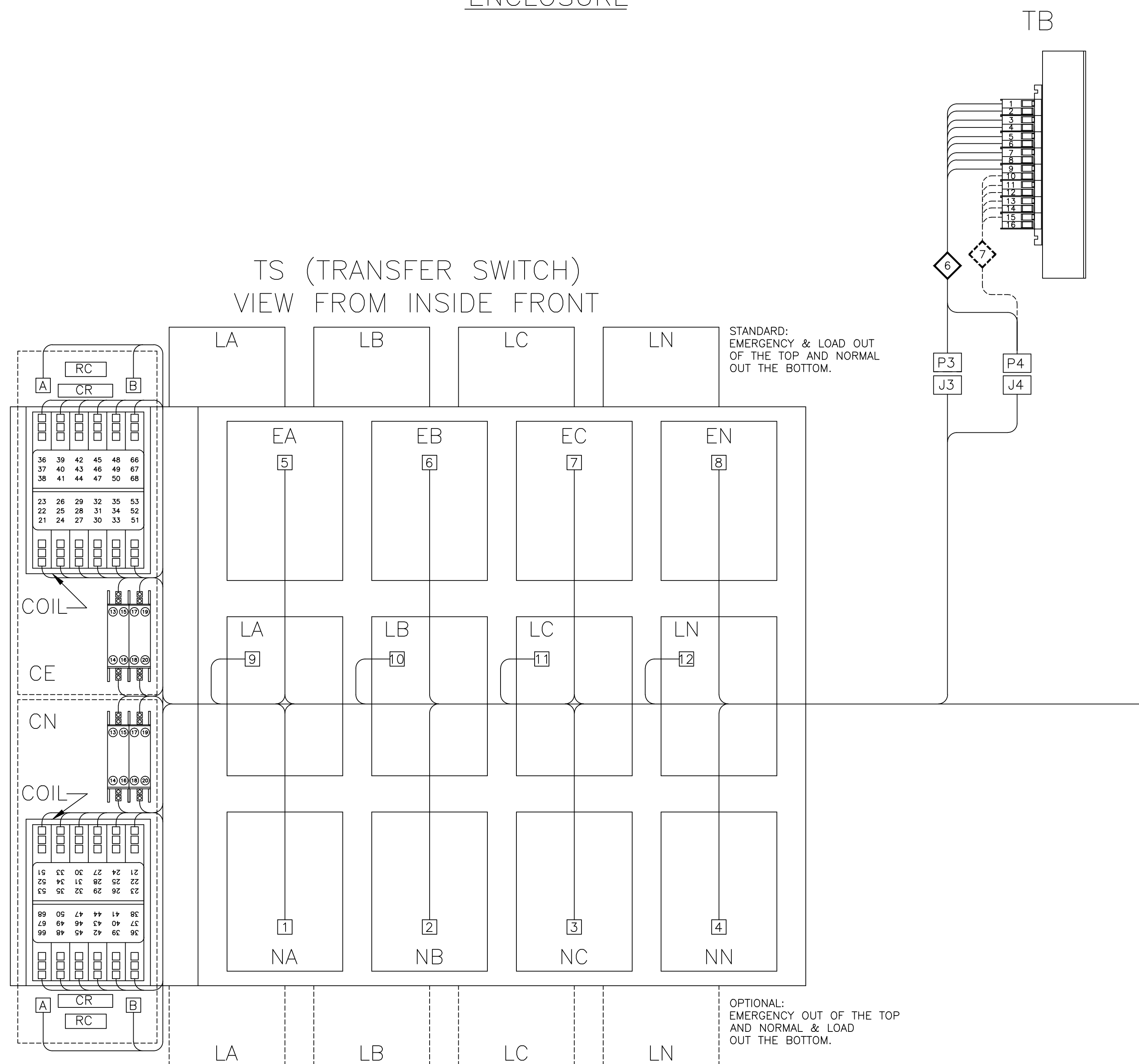

PROJECT NAME:		E 236871 TR BK 04/30/12	
REV. TO SHEET	ECN NO.	BY	APP. DATE
WIRING DIAGRAM		COMPUTER GENERATED DRAWING	
4000 SERIES (H4A/NCTS)3PH 600-1200 AMPS			
"H" FRAME, GROUP 5 CONTROLS			
DRAWN BY	DATE	MANUFACTURING TOLERANCES TO BE IN ACCORDANCE WITH ASCO PROCEDURE MP-1-003. FOR PLASTIC PARTS SEE MP-1-005.	SCALE NONE SIZE DS
CHECKED		PROPERTY OF ASCO POWER TECHNOLOGIES. USE PERMITTED FOR OUR WORK ONLY. ALL RIGHTS OF DESIGN OR INVENTION ARE RESERVED.	DWG. NO. 766510
PROJECT APPROVAL			DRAWING E ECN NO. 236871 SHEET 5 OF 6
FINAL APPROVAL	SDH 11/04	ASCO® ASCO POWER TECHNOLOGIES, L.P. FLOHAM PARK, NEW JERSEY 07932 U.S.A.	

