

**GREATER PINE ISLAND
WATER ASSOCIATION, INC.**



2023 Annual Drinking Water Quality Report



MISSION STATEMENT

Our mission at GPIWA is to produce clean, safe drinking water that exceeds all regulated standards and strive to deliver all services as cost effectively as possible with our member's interest in mind.

**5281 Pine Island Rd
Bokeelia, FL 33922
239-283-1071**

**This report is available on
our website:
www.pineislandwater.com**

Dear Members:

We at the Greater Pine Island Water Association Inc. (GPIWA) are very pleased to provide you with this year's Annual Water Quality Report. The GPIWA wants to keep you informed about the excellent water and services we have delivered to you this past year. Our goal is, and has always been, to provide you a safe and dependable supply of drinking water. The Greater Pine Island Water Association Inc. routinely monitors for contaminants in your drinking water according to Federal, State, and County laws, rules and regulations. Except where indicated otherwise, this report is based on the results of our monitoring for the period of January 1, 2023 to December 31, 2023. Data obtained before Jan. 1, 2023, and presented in this report is from the most recent testing done in accordance with the laws, rules, and regulations. We believe informed consumers are our best allies in maintaining a safe and reliable drinking water system.

“As authorized and approved by EPA, the State has reduced monitoring for certain contaminants to less often than once per year because the concentrations of these contaminants are not expected to vary significantly from year to year. Some of our data, though representative, is more than one year old.”

Safe water is vital to our community. We test our water daily ensuring we meet the highest standard possible using sophisticated equipment and advanced procedures. We are happy to show you how we have surpassed water quality standards. Please read this report carefully and if you have any questions, please call the main business office at 239-283-1071 Monday-Friday between 8:00am and 4:30pm or visit our website at www.pineislandwater.com. Landlords, businesses, and condominium associations are encouraged to share this report with non-billed water users. Additional copies are available at the Pine Island Center office.

We encourage public interest and participation in our Association's decisions affecting drinking water. Board meetings are typically held on the fourth Tuesday of the month, usually during the months of February, April, June, August, October, and December at the Pine Island Center office, 5281 Pine Island Road, at 10:00am. All members are welcome. The Annual Membership meeting is held on the fourth Tuesday in February. Please check our website for the next scheduled Board meeting.

Si usted quiere recibir este folleto en español, por favor llame al telefono 239-283-1071.

**We are proud to report that the water provided by the
Greater Pine Island Water Association, Inc.
meets or exceeds established water quality standards.**

Overview

In 1965 the Greater Pine Island Water Association, Inc. was formed. Since then, the Association has seen many changes and upgrades to its once small system. The largest change came in 1993, when the Greater Pine Island Water Association, Inc. began operation of its new 1.5 MGD Reverse Osmosis Water treatment facility. The water treated by the new plant was withdrawn from 3 deep wells. The next change came in 2002 when a plant upgrade allowed us to produce an additional 750,000 gallons of water per day. Also included in this expansion was the drilling of an additional well. With both projects completed the plant was then able to produce a total of 2.25 million gallons of water per day and store 5 million in its two storage tanks. In 2005 the Association completed the building of a pumping station in Matlacha with a storage capacity of 750,000 gallons of water. In 2009 a fifth deep well was added. From 2016 - 2021 the following neighborhoods received new upsized water mains to support fire hydrants previously not available: Charlotte Shores; Matlacha Isles; Shoreview Drive ; Fruit Streets Phase. The Association continues to make improvements to provide an adequate supply of potable water to our growing membership.



WATER SOURCE

Our system pumps groundwater from an aquifer known as the Lower Hawthorne by five production wells that are approximately 750 feet deep.

Reverse Osmosis (RO) is the method by which the impurities that occur naturally in our waters are removed. The two major impurities we deal with are chlorides and total dissolved solids (TDS). In 1998, Boyle Engineering, Inc. completed a water quality study for the Greater Pine Island Water Association, Inc. The conclusion of the report was that Greater Pine Island Water Association, Inc. has superior potable (drinking) water quality. For disinfection purposes the addition of liquid chlorine is added to the water before it is stored for delivery, this ensures its quality when it reaches your faucet.

The Greater Pine Island Water Association, Inc., as required by regulatory agencies, has undertaken lead and copper testing of individual member's tap water at various locations throughout our service area, in the years 1994, 1995, 1998, 2001, 2004, 2007, 2010, 2013, 2016, and 2019 and 2022. The next required sampling will be in the year 2025. We are pleased to report that in each of the sampling years there were no samples exceeding the maximum contaminant level for either lead or copper. To further protect our members from contaminants such as lead and copper from leaching into your water from piping and fixtures in your house, we add a corrosion inhibitor. This product also helps protect copper piping and metal fixtures in your house.

In 2021, the Florida Department of Environmental Protection performed a Source Water Assessment on our system. The assessment was conducted to provide information about any potential sources of contamination in the vicinity of our wells. There are five (5) potential sources of contamination identified for this system with a low susceptibility level. The assessment results are available on the FDEP Source Water Assessment and Protection Program website at www.prodapps.dep.state.fl.us/swapp or they can be obtained by calling customer service at 239-283-1071 between 8:30am and 4:30pm Monday through Friday.

DEPTH IN FEET	SERIES	FORMATION	LITHOLOGY	AQUIFER
0	HOLOCENE- PLEISTOCENE	FT. THOMPSON/ TAMIAMI	SAND, SANDSTONE AND SHELL, LIGHT GREY TO YELLOWISH GREY	WATER-TABLE AQUIFER
-100	PEACE RIVER FORMATION	CAPE CORAL CLAY MEMBER	CLAY, LIGHT GREY TO GREENISH GREY, SILTY, MINOR SHELL MATERIAL	CONFINING BEDS
		LEHIGH ACRES SS MBR.	SANDSTONE, LIGHT GREY	SANDSTONE AQUIFER
-200	MIOCENE	FORT MYERS CLAY MEMBER	CLAY, LIGHT GREY TO GREENISH GREY, PHOSPHATIC, SANDY, INTERBEDDED LAYERS	CONFINING BEDS
-300		ARCADIA FORMATION	UPPER MID HAWTHORN LIMESTONE MEMBER	LIMESTONE, LIGHT GREY, PHOSPHATIC, FOSSILIFEROUS, SOME MINOR INTERBEDDED SANDSTONE AND LIME MUD LAYERS
-400	HAWTHORN GROUP	UNNAMED CLAY MEMBER	MARL, WHITE TO LIGHT GREY, PHOSPHATIC, INTERBEDDED LIMESTONE	CONFINING BEDS
-500		LOWER MID HAWTHORN LIMESTONE MEMBER	LIMESTONE, LIGHT BROWN TO YELLOWISH GREY, MARLY, PHOSPHATIC, FOSSILIFEROUS, SOME INTERBEDDED	MID HAWTHORN ZONE II AQUIFER
		UNNAMED MEMBER	LIME MUD, LIGHT GRAY, PHOSPHATIC	CONFINING BEDS
-600	HAWTHORN GROUP	LOWER HAWTHORN LIMESTONE MEMBER	LIMESTONE, LIGHT GREY TO YELLOWISH GREY, FOSSILIFEROUS, FAIR TO GOOD PHOSPHATIC, MINOR INTERBEDDED MARL, DOLOMITIC NEAR BASE, WITH SOME VERY THIN CLAY LAYERS	LOWER HAWTHORN AQUIFER
-800		SUWANNEE FORMATION	LIMESTONE, MICRITIC, NUMEROUS DOLOMITE, CALCAREOUS, SANDY	UPPER FLORIDIAN AQUIFER
-1300		OCALA FORMATION	LIMESTONE, MICRITIC, NUMEROUS LARGE FORAMS, MINOR CLAY	



DID YOU KNOW?

In 2023, approximately 622 million gallons of water was distributed to our customers. We are almost completed with repairing damage in Matlacha due to Hurricane Ian.

Reverse Osmosis Water Treatment Plant

Reverse Osmosis

Reverse osmosis (RO) is the opposite of osmosis, a process occurring in nature. Osmosis can be defined as the passage of a liquid from a freshwater solution to a more concentrated saltwater solution across a semi-permeable membrane. The semipermeable membrane allows the passage of the water, but not the dissolved contaminants, such as salt. Reverse osmosis is accomplished by applying pressure to a concentrated saltwater solution forcing the pure water to flow through the semipermeable membrane to the weak freshwater side. Reverse Osmosis rejects between 98 and 99 percent of dissolved solids (salts), color, bacteria, radioactive substances, and other inorganic or organic chemicals that may be present in ground water systems.

Treatment Process

Source water entering the plant is called raw water. Upon entry, a scale inhibitor is injected to prevent scaling. The addition of this chemical is commonly referred to as "pretreatment". At this point, the raw water becomes the feed water. After pretreatment, the feed water enters a series of cartridge filters.

Upon passing through the cartridge filters, the water is pumped with high pressure pumps into the RO production units for primary treatment. When the feed water travels across the RO membrane elements, it is separated into usable (product) and non-usable (concentrate) water. Pretreatment keeps dissolved solids in liquid form during this separation. As required by permit, the concentrate is then discharged from the system by way of a pipeline to a deep injection well.

The amount of concentrate removed in the RO process is approximately 15% of the feed water entering the system. The concentrate water is not drinkable nor is it suitable for irrigation due to the high dissolved solids concentration.

After the RO units separate the water into product and concentrate, the product water flows towards the degasifiers. Product water coming out of the RO units is of such high purity that it has little or no hardness. Prior to entering the degasifiers, some raw water is blended with the product water to increase alkalinity and hardness to a moderate level. This produces a more stable finished water for corrosion control. At this point, the water is called blend product. Approximately 17% of the total blend product is blend water.

The blend product water now enters the degasifiers where hydrogen sulfide is stripped from the water. Hydrogen sulfide produces the objectional sulfur or "rotten egg" odor often found in well water. Blend product water cascades down into the degasifiers. It is forcibly mixed with air from a blower. The air strips the hydrogen sulfide from the water, and the combined hydrogen sulfide and air leaves through a tower connected to the top of the degasifiers. The water now falls into the clearwell where chlorine and caustic soda are added. Liquid chlorine (sodium hypochlorite) is added for disinfection and removal of any remaining hydrogen sulfide not removed by the degasifiers. Also, orthophosphate is added to the water for corrosion inhibitor. Caustic soda (sodium hydroxide) also is added to raise the pH of the water. This pH adjustment is the final step in the process of stabilizing the water for corrosion control. From the clearwell, the water is pumped to storage tanks where it is called finished water. At this point, it is available for pumping to the consumer.



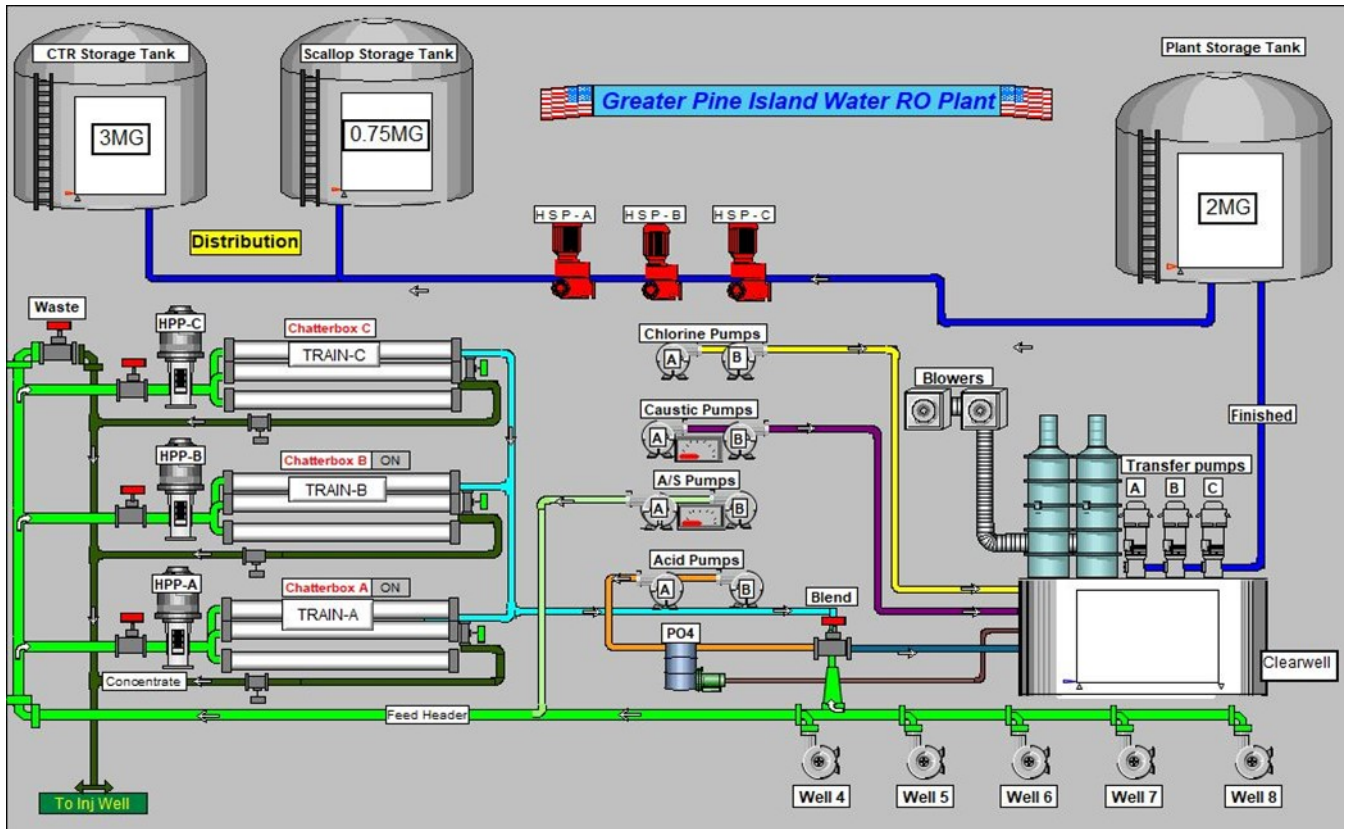

RO Treatment Process



New Equipment for Distribution Department -Vacuum Excavator

ADDITIONAL HEALTH INFORMATION

Some people may be more vulnerable to contaminants in drinking water than is the general population. Immuno-compromised persons such as persons with cancer undergoing chemotherapy, persons who have undergone organ transplants, people with HIV/AIDS or other immune system disorders, some elderly, and infants can be particularly at risk from infections. These people should seek advice about drinking water from their health care providers.

In order to ensure that tap water is safe to drink, the EPA prescribes regulations which limit the amount of certain contaminants in water provided by public water systems. The Food & Drug Administration (FDA) regulations also establish limits for contaminants in bottled water which must provide the same protection for public health. Drinking water, including bottled water, may reasonably be expected to contain at least small amounts of some contaminants. The presence of contaminants does not necessarily indicate that water poses a health risk. More information about contaminants and potential health effects can be obtained by calling the Environmental Protection Agency's Safe Drinking Water Hotline (1-800-426-4791).

If present, elevated levels of lead can cause serious health problems, especially for pregnant women and young children. Lead in drinking water is primarily from materials and components associated with service lines and home plumbing. GPIWA is responsible for providing high quality drinking water but cannot control the variety of materials used in plumbing components. When your water has been sitting for several hours, you can minimize the potential for lead exposure by flushing your tap for 30 seconds to 2 minutes before using water for drinking or cooking. If you are concerned about lead in your water, you may wish to have your water tested. Information on lead in drinking water, testing methods, and steps you can take to minimize exposure is available from the Safe Drinking Water Hotline at 1-800-426-4791 or <http://www.epa.gov/safewater/lead>.

Although Cryptosporidium is not a problem associated with groundwater supply, US Environmental Protection Agency/Center for Disease Control guidelines on appropriate means to lessen the risk of infection by Cryptosporidium and other microbiological contaminants are available from the Safe Drinking Water Hotline (800-426-4791).

The sources of drinking water (both tap water and bottled water) include rivers, lakes, streams, ponds, reservoirs, springs, and wells. As water travels over the surface of the land or through the ground, it dissolves naturally occurring minerals and, in some cases, radioactive material, and can pick up substances resulting from the presence of animals or from human activity. Contaminants that may be present in source water include:

Microbial contaminants, such as viruses and bacteria, which may come from sewage treatment plants, septic systems, agriculture livestock operations, and wildlife.

Inorganic contaminants, such as salts and metals, which can be naturally occurring or result from urban stormwater runoff, industrial or domestic wastewater discharges, oil and gas production, mining, or farming.

Pesticides and herbicides, which may come from a variety of sources such as agriculture, urban storm water runoff, and residential uses.

Organic chemical contaminants, including synthetic and volatile organic chemicals, which are by-products of industrial processes and petroleum production, and can also come from gas stations, urban storm water runoff and septic systems.

Radioactive contaminants, which can be naturally occurring or be the result of oil and gas production and mining activities.

How to Read The Test Result Table

The Greater Pine Island Water Association, Inc. routinely monitors for contaminants in the drinking water according to Federal and State laws. Because we regularly exceed Federal and State standards, we have been granted reduced testing for many of the required contaminants. Therefore, some tests are conducted less frequently than once a year. If the test was not performed in 2023, then the most recent analysis is listed.

The Water Quality Data Table in the CCR lists only the contaminants that were detected. The table contains the name of each substance, the highest level allowed by regulation (MCL) and the amount detected along with a description of the contaminants major source. For a list of all regulated contaminants tested, visit our website at www.pineislandwater.com, Water Quality Reports Tab. **In addition to these we also tested for many contaminants that were not detected. Results from the most recent testing required by EPA show that the following contaminants were not detected:**

Synthetic Organics: Endrin, Lindane, Methoxychlor, Toxaphene, Dalapon, Diquat, Endothall, Glyphosate, Di(2-ethylhexyl) adipate, Oxamyl (Vydate), Simazine, Di (2-ethylhexyl)phthalate, Picloram, Dinoseb, Hexachlorocyclopentadiene, Carbofuran, Atrazine, Alachlor, Heptachlor, Heptachlor epoxide, 2,4-D, 2,4,5-TP, Hexachlorobenzene, Benzo(a)pyrene, Pentachlorophenol, Polychlorinated biphenylsPCB, Dibromochloropropane, Ethylene Dibromide, Chlorodane

Volatile Organics: 1,2,4-Trichlorobenzene, cis-1,2-Dichloroethylene, Xylenes (total), Dichloromethane, o-Dichlorobenzene, para-Dichlorobenzene, Vinyl Chloride, 1,1-Dichloroethylene, trans-1,2-Dichloroethylene, 1,2-Dichloroethane, 1,1,1-Trichloroethane, Carbon tetrachloride, 1,2-Dichloropropane, Trichloroethylene, 1,1,2-Trichloroethane, Tetrachloroethylene, Monochlorobenzene, Benzene, Toluene, Ethylbenzene, Styrene.

Inorganic Contaminants: Asbestos, Arsenic, Cadmium, Chromium, Cyanide, Lead, Mercury, Selenium, Antimony, Beryllium, Thallium, Nitrite, Nickel

Secondary Contaminants: Aluminum, Manganese, Silver, Odor, Foaming Agents, Copper, Color, Iron, Zinc

Terms and Abbreviations

In the table below, you may find unfamiliar terms and abbreviations. To help you better understand these terms we've provided the following definitions:

AL=Action Level – the concentration of a contaminant which, if exceeded, triggers treatment or other requirements that a water system must follow.

MCL=Maximum Contaminant Level – the highest level of a contaminant that is allowed in drinking water. MCLs are set as close to the MCLGs as feasible using the best available treatment technology.

MCLG=Maximum Contaminant Level Goal – the level of a contaminant in drinking water below which there is no known or expected risk to health. MCLGs allow for a margin of safety.

MRDL=Maximum Residual Disinfectant Level – the highest level of a disinfectant allowed in drinking water. There is convincing evidence that the addition of a disinfectant is necessary for control of microbial contaminants.

MRDLG=Maximum Residual Disinfectant Level Goal – the level of a drinking water disinfectant below which there is no known or expected risk to health. MRDLGs do not reflect the benefits of the use of disinfectants to control microbial contaminants.

ND=Not Detected

pCi/L=picocuries per liter – a measure of the radioactivity in water.

ppm=parts per million or Milligrams per liter (mg/l) – one part by weight of analyte to 1 million parts by weight of the water sample.

ppb=parts per billion or Micrograms per liter (ug/l) – one part by weight of analyte to 1 billion parts by weight of the water sample.

TT=Treatment Technique – a required process intended to reduce the level of a contaminant in drinking water.

Water Quality Table footnotes:

GPIWA does not test for Cryptosporidium. This is not a problem associated with groundwater.

GPIWA does not test for radon. DEP has not set regulations for testing.

GPIWA does not add fluoride to the water supply. Any detected level present is naturally occurring trace amounts.

National Primary Drinking Water Regulation Compliance

More information on Water Quality Data for community water systems throughout the United States is available at <https://www.epa.gov/ground-water-and-drinking-water>.

Non-Secondary Contaminants Table

Radioactive Contaminants (Next sampling date is 2026)

Contaminant and Unit of Measurement	Dates of sampling (mo./yr.)	MCL Violation Y/N	Level Detected	Range of Results	MCLG	MCL	Likely Source of Contamination
Alpha emitters (pCi/L)	03/2023	No	12.1	12.1	0	15	Erosion of natural deposits
Radium 226 + 228 or combined radium (pCi/L)	03/2023	No	2.1	2.1	0	5	Erosion of natural deposits

Inorganic Contaminants (Next sampling date is 2026)

Contaminant and Unit of Measurement	Dates of sampling (mo./yr.)	MCL Violation Y/N	Level Detected	Range of Results	MCLG	MCL	Likely Source of Contamination
Sodium (ppm)	03/2023	No	74.8	74.8	N/A	160	Salt water intrusion, leaching from soil
Barium (ppm)	03/2023	No	.0024	.0024	2	2	Discharge of drilling wastes; discharge from metal refineries; erosion of natural deposits
Fluoride (ppm)	03/2023	No	.220	.220	4	4.0	Erosion of natural deposits; discharge from fertilizer and aluminum factories. Water additive which promotes strong teeth when the optimum level of 0.7 ppm
Nitrate (as Nitrogen) (ppm)	3/2023	No	.12	.12	10	10	Runoff from fertilizer use; leaching from septic tanks, sewage; erosion of natural deposits

Stage 1 Disinfectants/Disinfection By-Products

Contaminant and Unit of Measurement	Dates of sampling (mo./yr.)	MCL Violation Y/N	Level Detected	Range of Results	MCLG	MCL or MRDL	Likely Source of Contamination
Chlorine (ppm)	01/2023 - 12/2023	No	1.66	1.0 – 3.7	MRDLG 4	MRDL 4	Water additive used to control microbes

Stage 2 Disinfectants/Disinfection By-Products

Contaminant and Unit of Measurement	Dates of sampling (mo./yr.)	MCL Violation Y/N	Level Detected	Range of Results	MCLG	MCL or MRDL	Likely Source of Contamination
Haloacetic Acids (five) (HAA5) (ppb)	08/2023	No	7.5	5.7– 7.5	N/A	60	By-product of drinking water disinfection
TTHM [Total trihalomethanes] (ppb)	08/2023	No	39.4	28.3 - 39.4	N/A	80	By-product of drinking water disinfection

Lead and Copper (Tap Water)

Contaminant and Unit of Measurement	Dates of sampling (mo./yr.)	MCL Violation Y/N	Level Detected	Range of Results	MCLG	MCL or MRDL	Likely Source of Contamination
Copper (tap water) (ppm)	07/2022	No	.0058	0	1.3	1.3	Corrosion of household plumbing systems; erosion of natural deposits; leaching from wood preservatives
Lead (tap water) (ppb)	07/2022	No	.23	0	0	15	Corrosion of household plumbing systems; erosion of natural deposits

Secondary Contaminants Table

Secondary Contaminants

Contaminant and Unit of Measurement	Dates of sampling (mo./yr.)	MCL Violation Y/N	Level Detected	Range of Results	MCLG	MCL	Likely Source of Contamination
Chloride (ppm)	03/2023	No	139	139		250	Natural occurrence from soil leaching
Sulfate (ppm)	03/2023	No	51.6	51.6		250	Natural occurrence from soil leaching
Total Dissolved Solids (ppm)	03/2023	No	292	292		500	Natural occurrence from soil leaching

Frequently Asked Questions

Does GPIWA add fluoride to the water supply?

No, we do not add fluoride to our water treatment process. A small amount of fluoride exists naturally in the groundwater.

Do I need a water softener?

No, GPIWA water is in the industry accepted range of soft to moderately hard. This is the most desirable range for consumers. Water that is too soft makes it very difficult to remove soap from your hands or detergent from your laundry. Water that is too hard requires an increased use of soap or detergent to adequately clean.

What is the hardness of GPIWA water?

My dishwasher operator's manual says that the amount of dishwashing detergent I need to use depends on the grains per gallon of hardness in the water. GPIWA water has approximately 4 grains per gallon of total hardness.

Do I need a kitchen sink filter on my water?

Water produced by GPIWA does not need further filtering. However if you are not accustomed to the taste of treated water you may want to consider a filter that is attached to your faucet. We do not recommend kitchen under sink filters unless the customer is diligent in keeping the filter clean. Filters not kept in good working order will make your tap water have an odd taste and may make the water discolored.

CURRENT BOARD OF DIRECTORS

JOHN CAMMICK - PRESIDENT
WILLIAM DIELE - VICE PRESIDENT
P MICHAEL ROSE - TREASURER
FRANK POTTER - SECRETARY
PAUL BROWN
DENNIS DEKKER
MIKE DREIKORN
TOM FERGUSON
ILA VALCARCEL



New Roof Completed at Water Treatment Plant from Hurricane Ian Damage

