

Daihatsu

HiJet Truck and Vans

Full Electrical Diagrams



2WD 4WD

HiJet Pickup & Van

660cc

All Versions

Including Dump & Diff-Lock

V-S100

V-S110

V-S120

V-S130

V-S140

Truck

Van

**Written by,
James Danko**

Japanese Mini Truck Series Manuals

Daihatsu

HiJet

Trucks Vans

Full Electrical Diagrams

2WD & 4WD

Including,

Dumps and Diff-Lock Series

**Written By,
James Danko**

Japanese Mini Truck Series manuals

Copyright© James L. Danko

Daihatsu Full Electrical Series (Carbureted Version)

First Edition 2008

Published: Tokyo, Japan and USA-Canada by

lulu.com

All photographs and or Diagrams are property of Yokohama Motors Inc., a wholly owned division of Nippon Security K.K Japan. Photographs and or graphics may not be reproduced without written permission.

Computer Graphics by Yoshiro (YoYo)

www.yoshiro.com

Special thanks to the Daihatsu Corporation Japan for supplying the technical details. Any and all technical information has been translated from Japanese to English.

Any and all Japanese further translations from Japanese to English Copyright James L. Danko

Disclaimer: All contents of this book stress safety factor. You must use proper safety equipment at all times while performing maintenance.

Daihatsu and Hijet Series Vehicles are

Copyright ©Daihatsu Motor Corporation, Japan

Yokohama Motors, Japan www.yokohamamotors.com

Contents

Hijet Truck, Panel Van, Van 2WD & 4WD

1. Main Power Circuit
2. Ignition and Emission Control
3. Starter & Alternator Power Circuit
4. Electrical Connector Location and Pin Numbers (Truck & Panel Van)
5. Electrical Connector Location and Pin Numbers (Van)
6. Diff-Lock Differential & Back Lamp MT Manual Transmission
7. Stop Lamp, Brake Light, Room-Dome Lamps
8. Tail Lamp, Clear lamps, License, Meter Panel, Heater Control Lamps
9. Headlight Circuits
10. Turn Signal, Hazard, Horn Circuits
11. Radiator Cooling Fan (Truck, Van)
12. Part Time 4WD System (Hi-Low)
13. Dump Truck Pump and Switching Circuit
14. Fuel Injection Systems Diagrams (Including Computer ECM)

Main Power Circuit

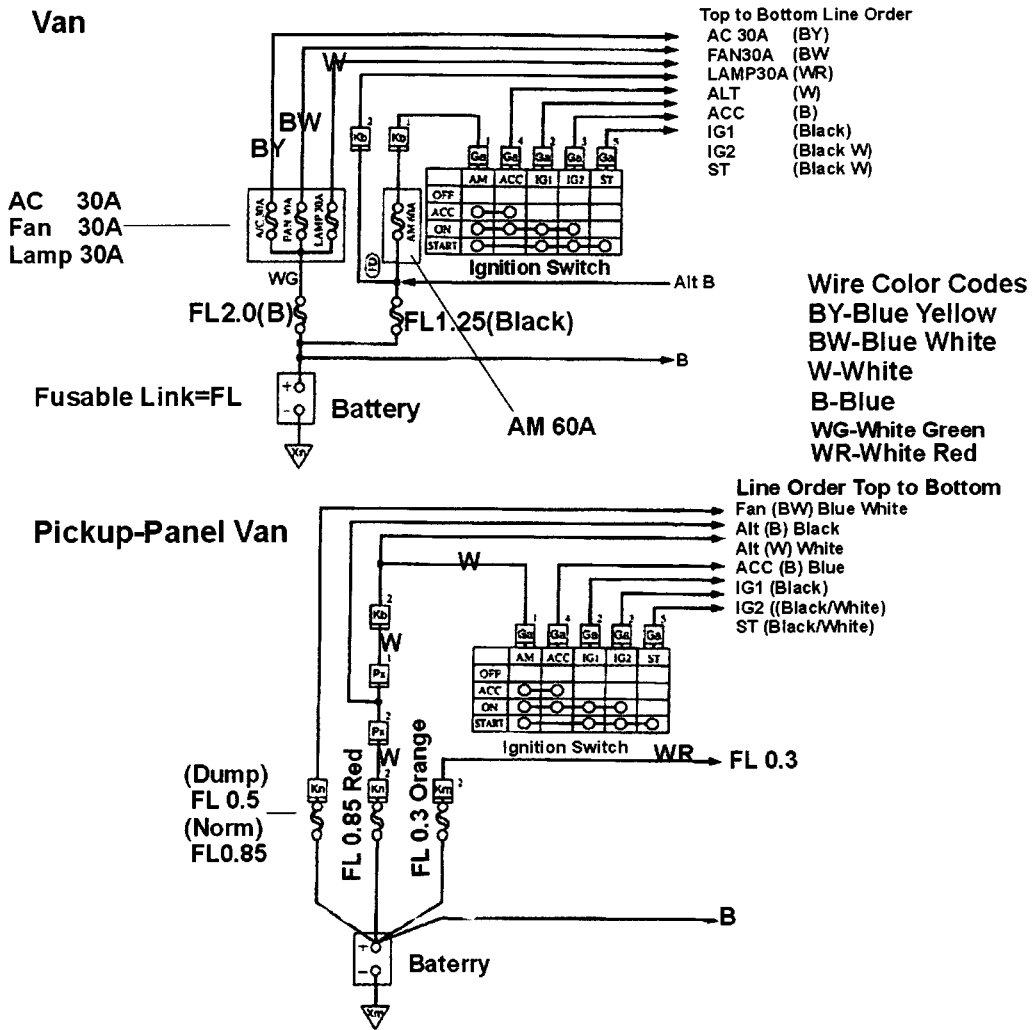

Connectors & Pin Numbers

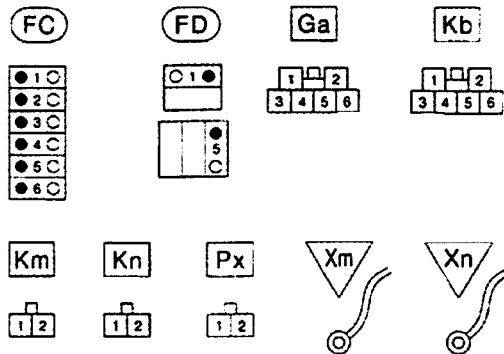

Ignition & Emission Control Daihatsu Truck-Van

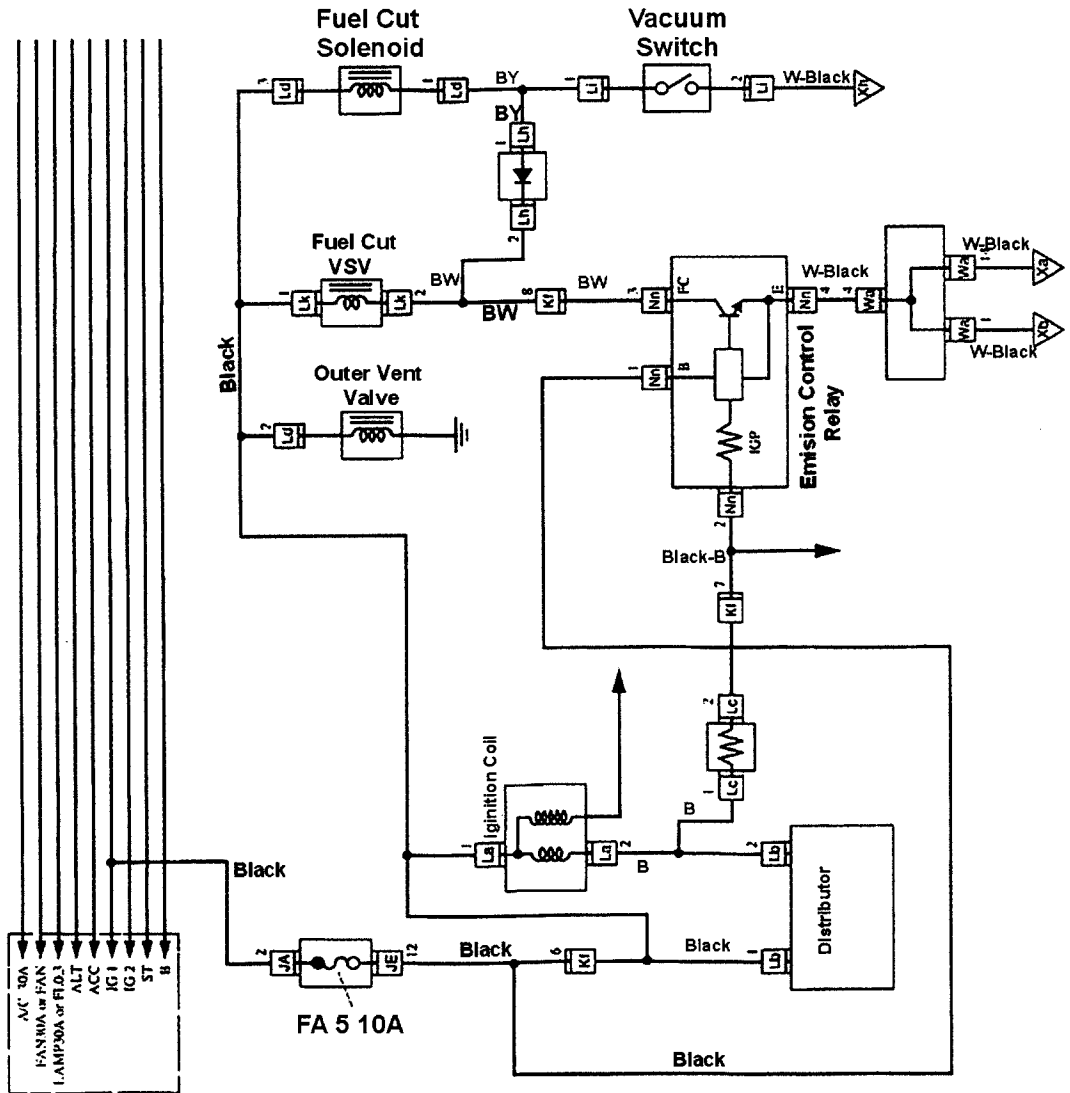

Starter & Alternator Power Circuit Daihatsu Van & Truck

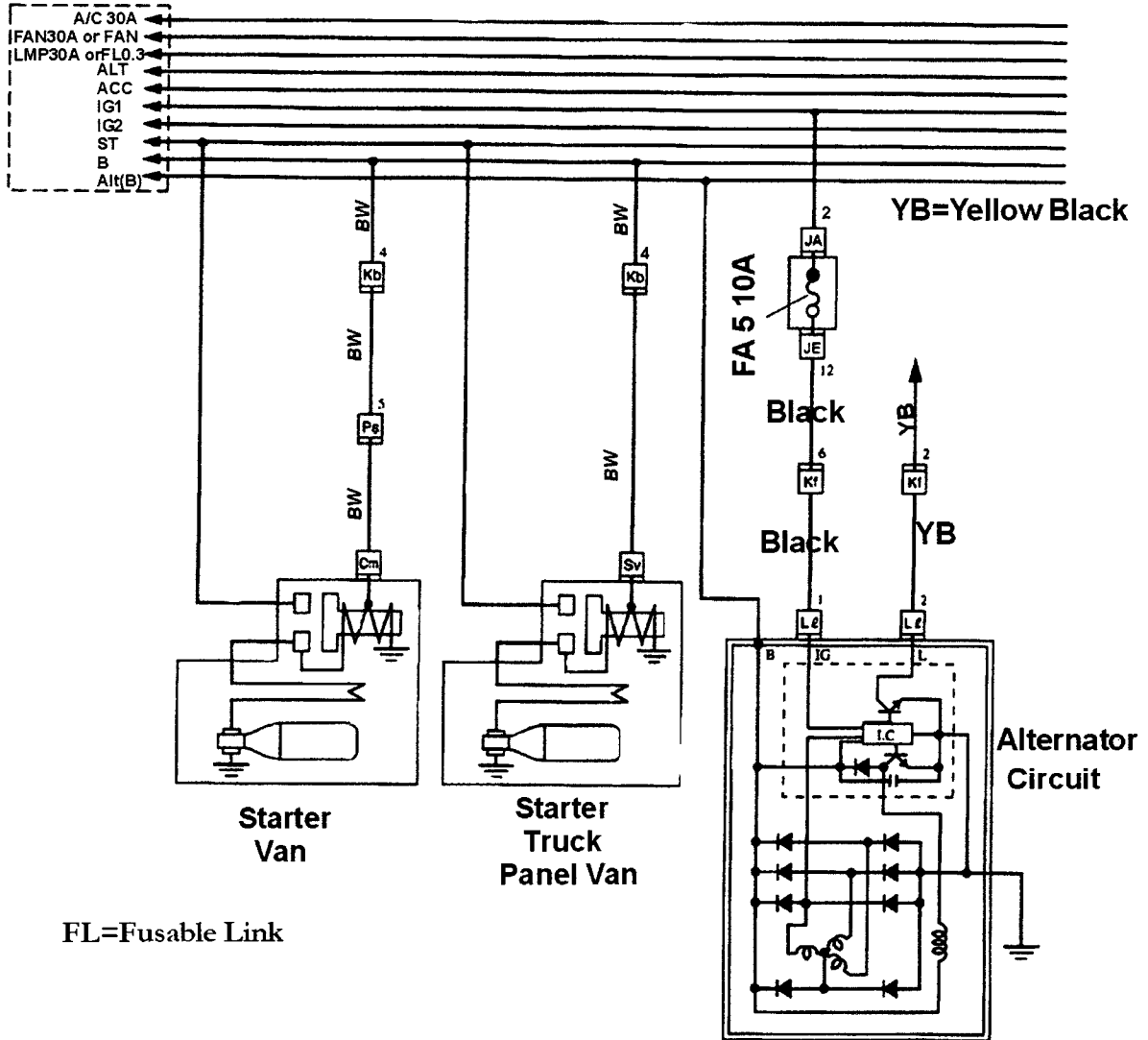

Connectors & Pin Numbers

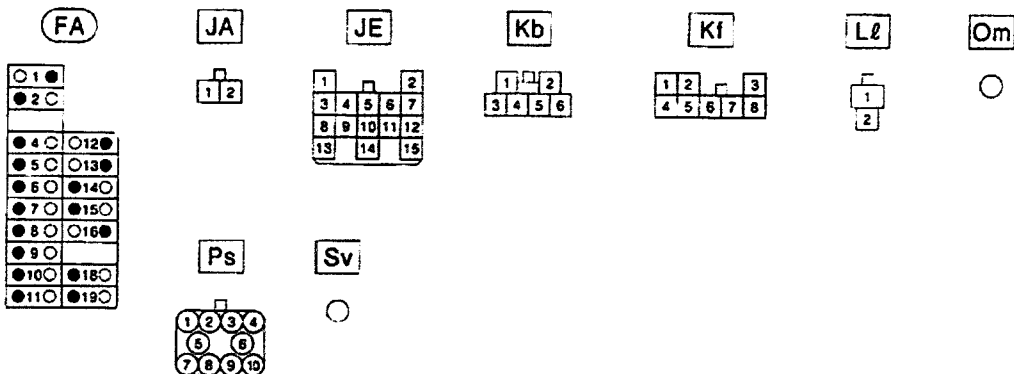

Yokohama Motors [English] Daihatsu

Daihatsu Connector Location Truck & Panel Van

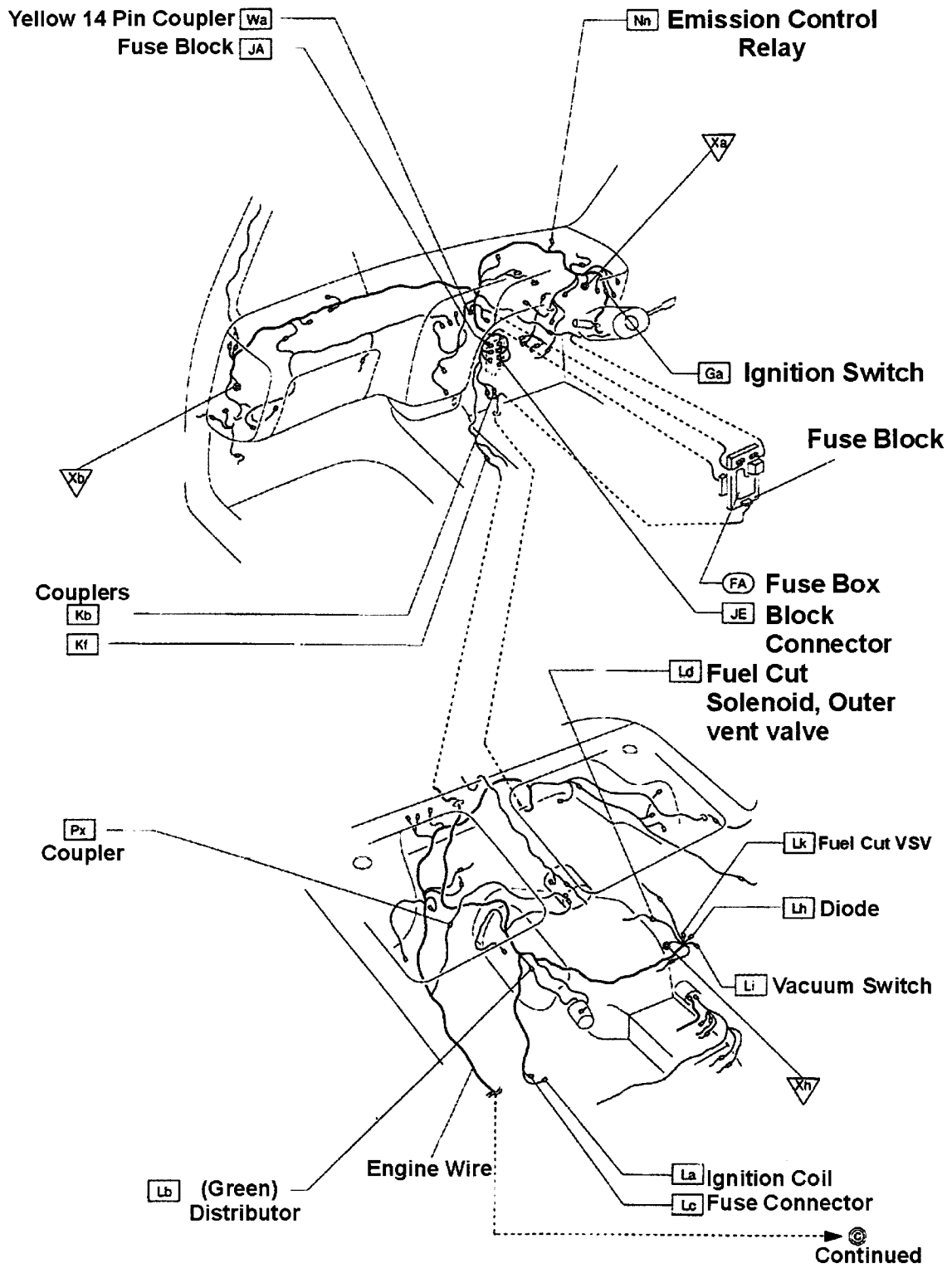

Daihatsu Connector Location Van

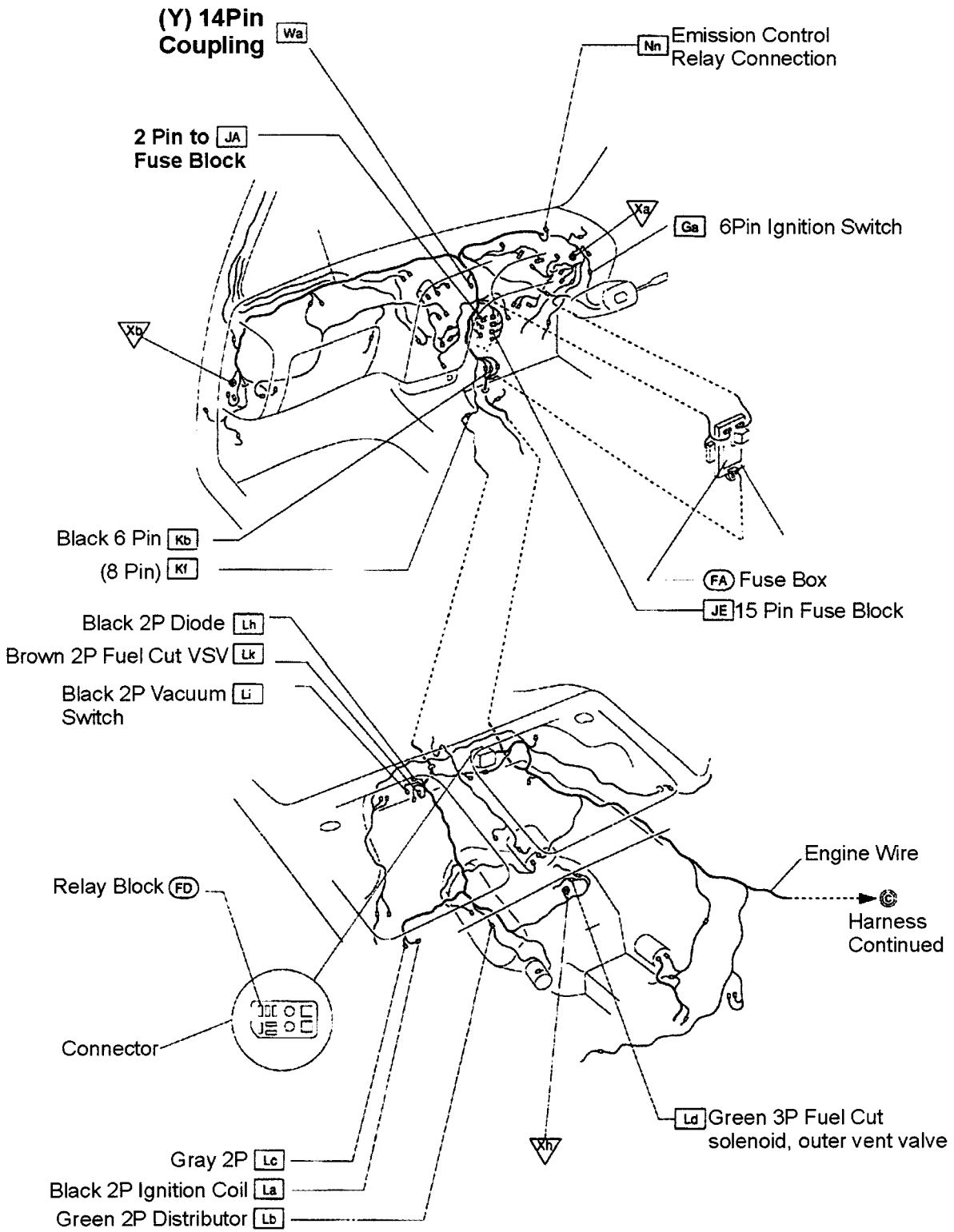

www.yokohamamotors.com

Diff-Lock & Non-Diff Lock+Back Lamp MT Manual Transmission

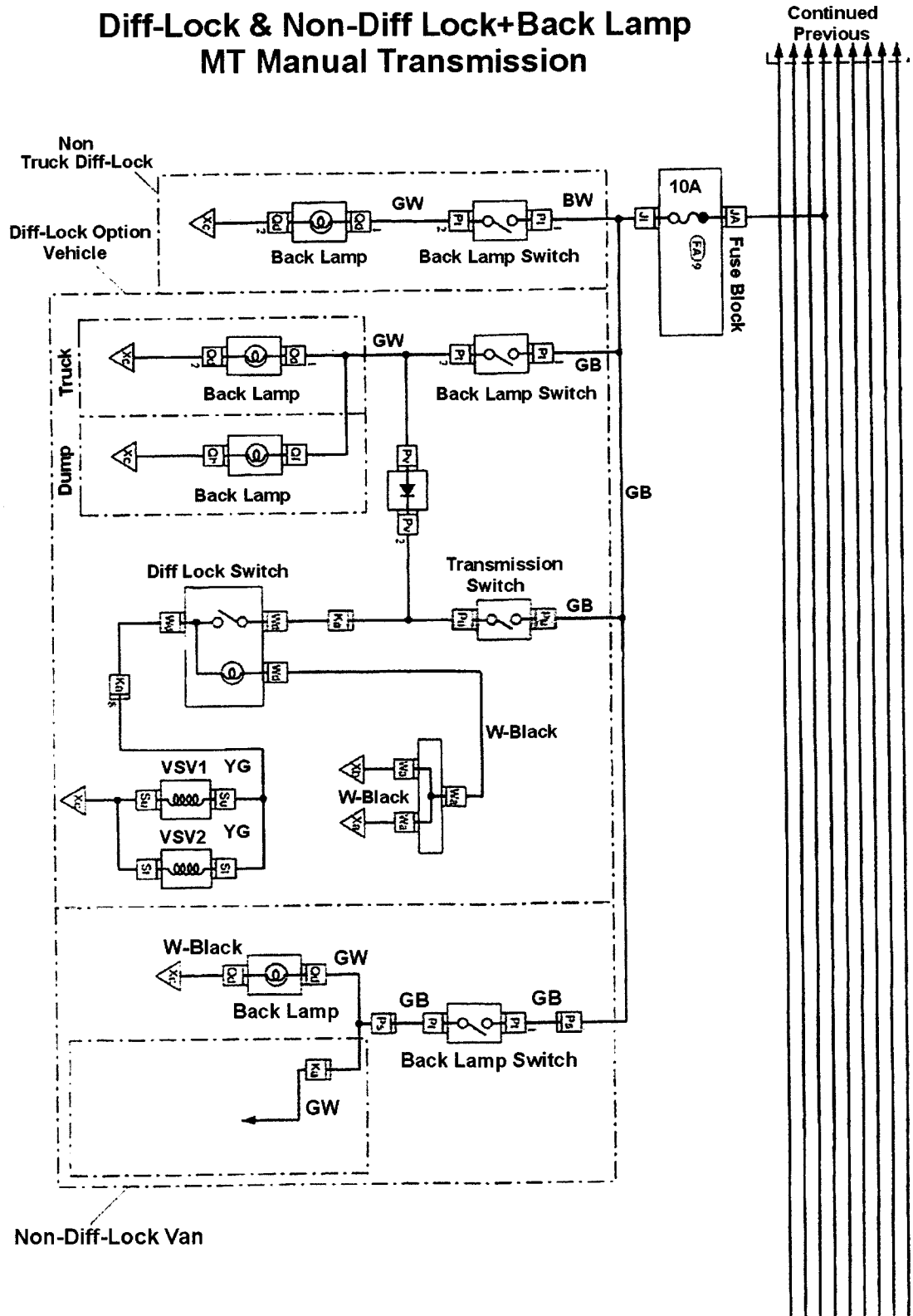

Stop Lamp-High Mount Brake Light-Room & Dome Lamps

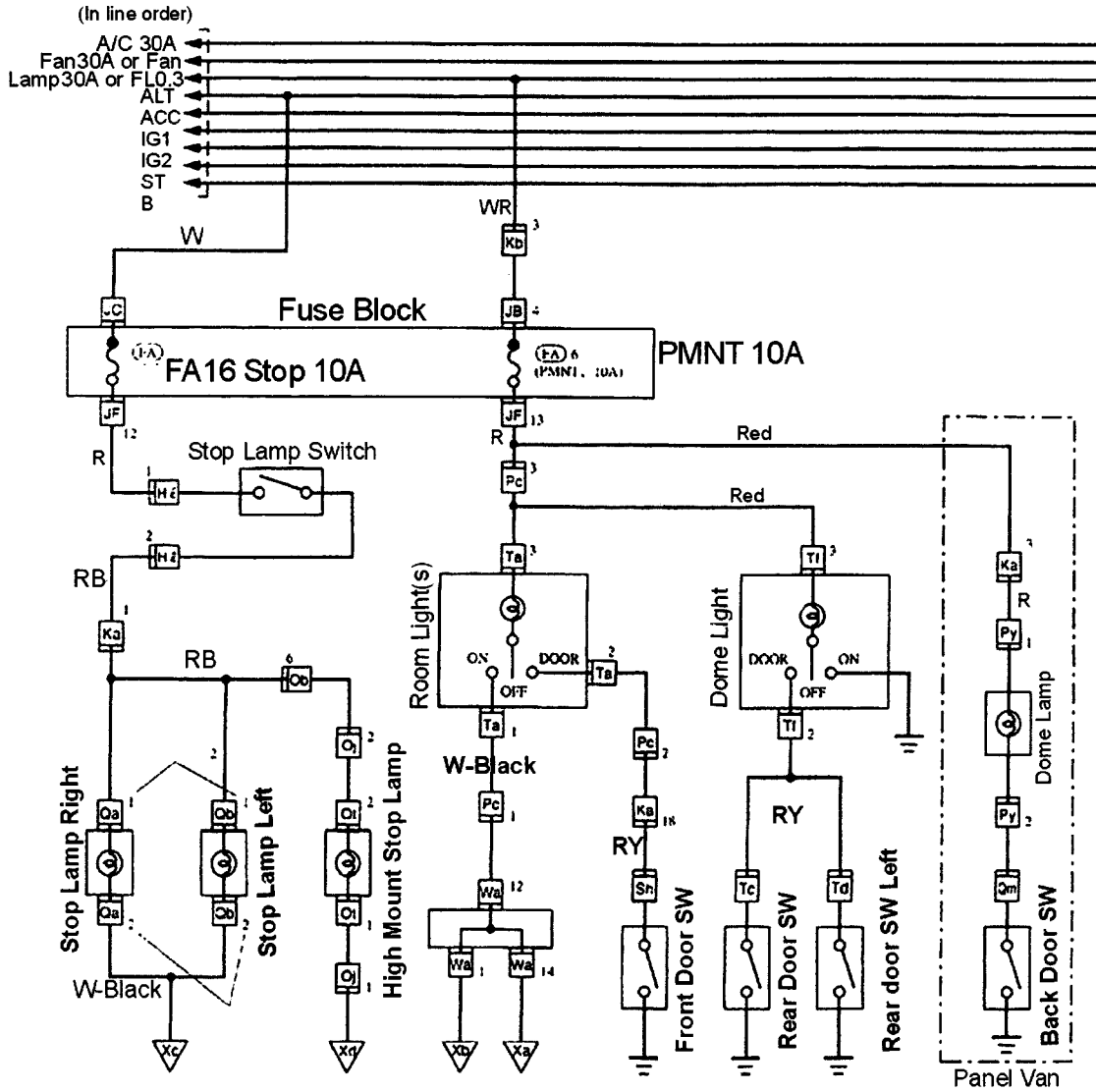

Connectors & Pin Numbers

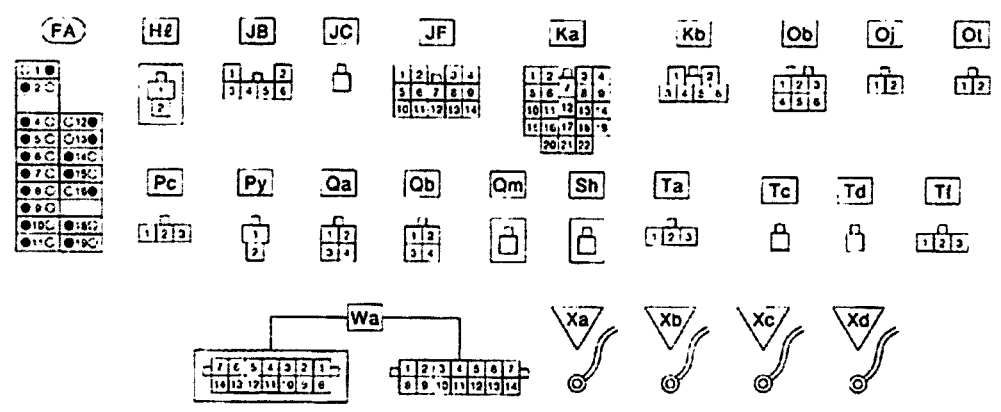

Tail Lamp. Clear Lamps, License Lamps Meter Panel Lamps, Heater Control Light

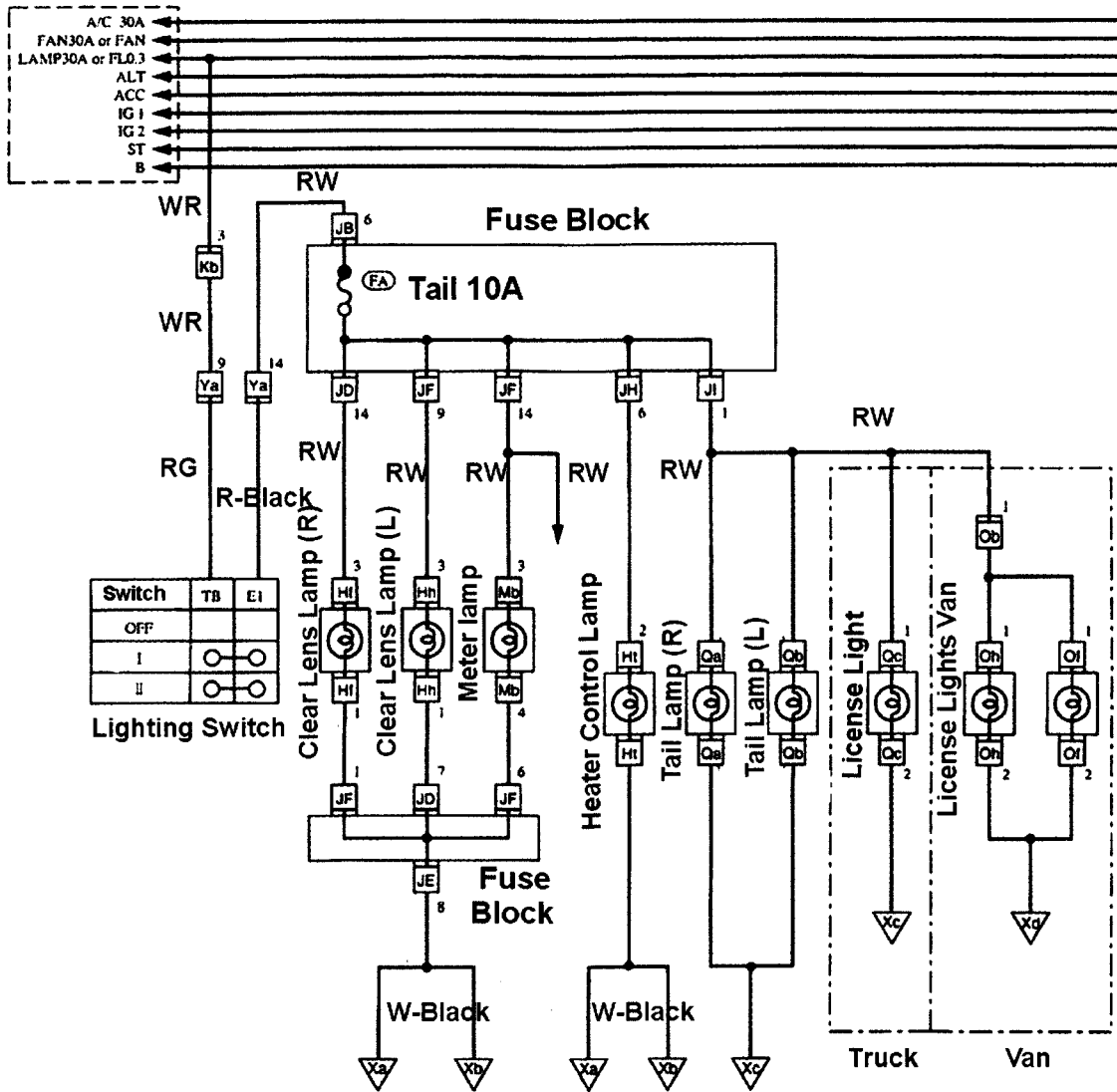

Connectors & Pin numbers

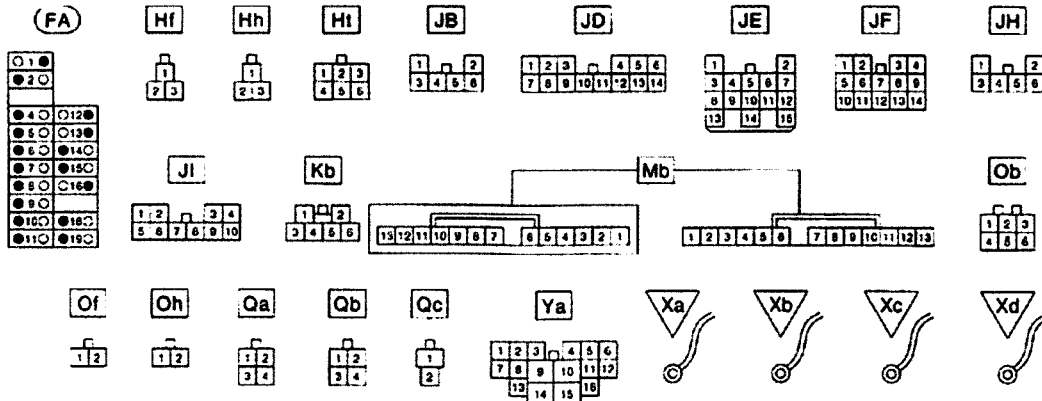

Headlight System

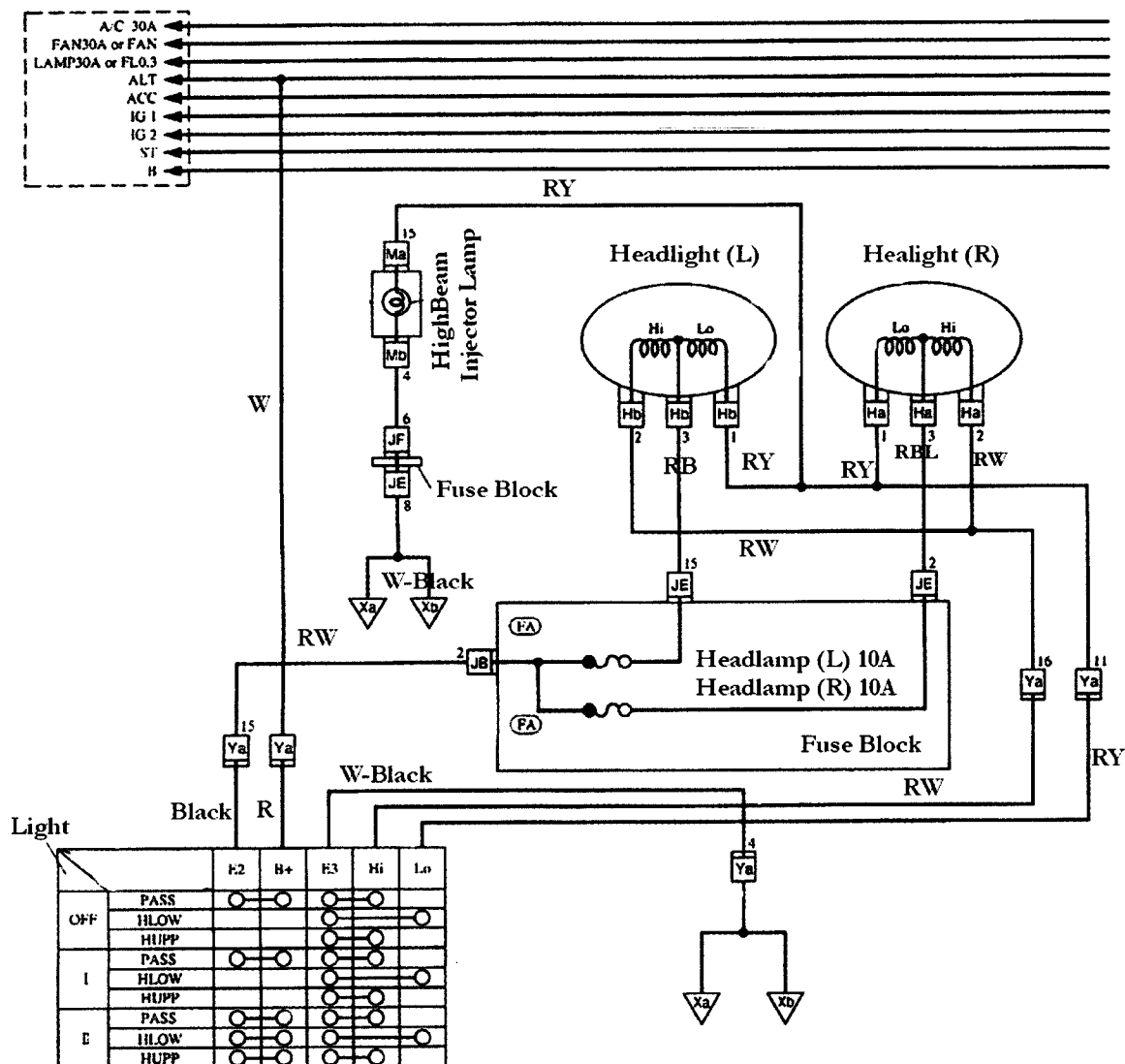

Light

		F2	H+	F3	Hi	Lo
OFF	PASS	○	○	○	○	○
	HLOW	○	○	○	○	○
	HUPP	○	○	○	○	○
I	PASS	○	○	○	○	○
	HLOW	○	○	○	○	○
	HUPP	○	○	○	○	○
E	PASS	○	○	○	○	○
	HLOW	○	○	○	○	○
	HUPP	○	○	○	○	○

Connectors & Pin Numbers

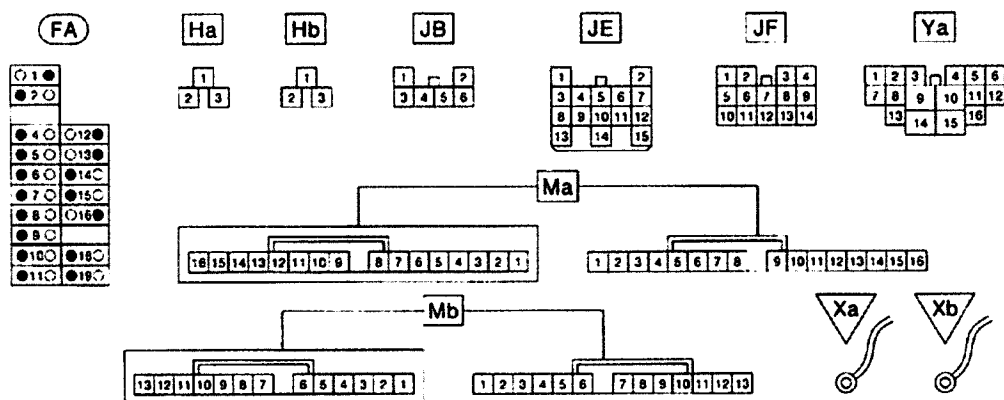

Turn Signal, Hazard Horn

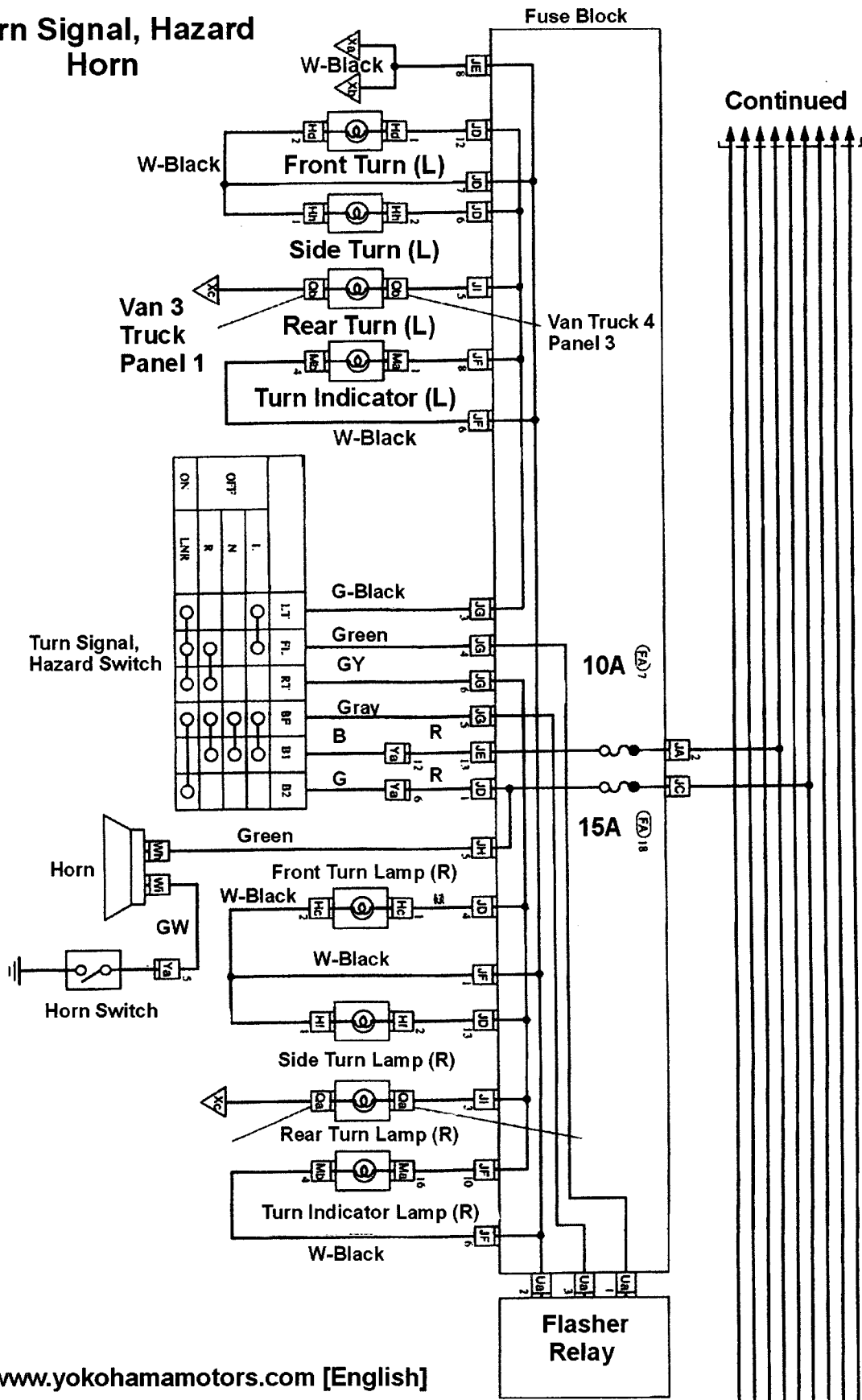

Radiator Cooling Fan Circuit

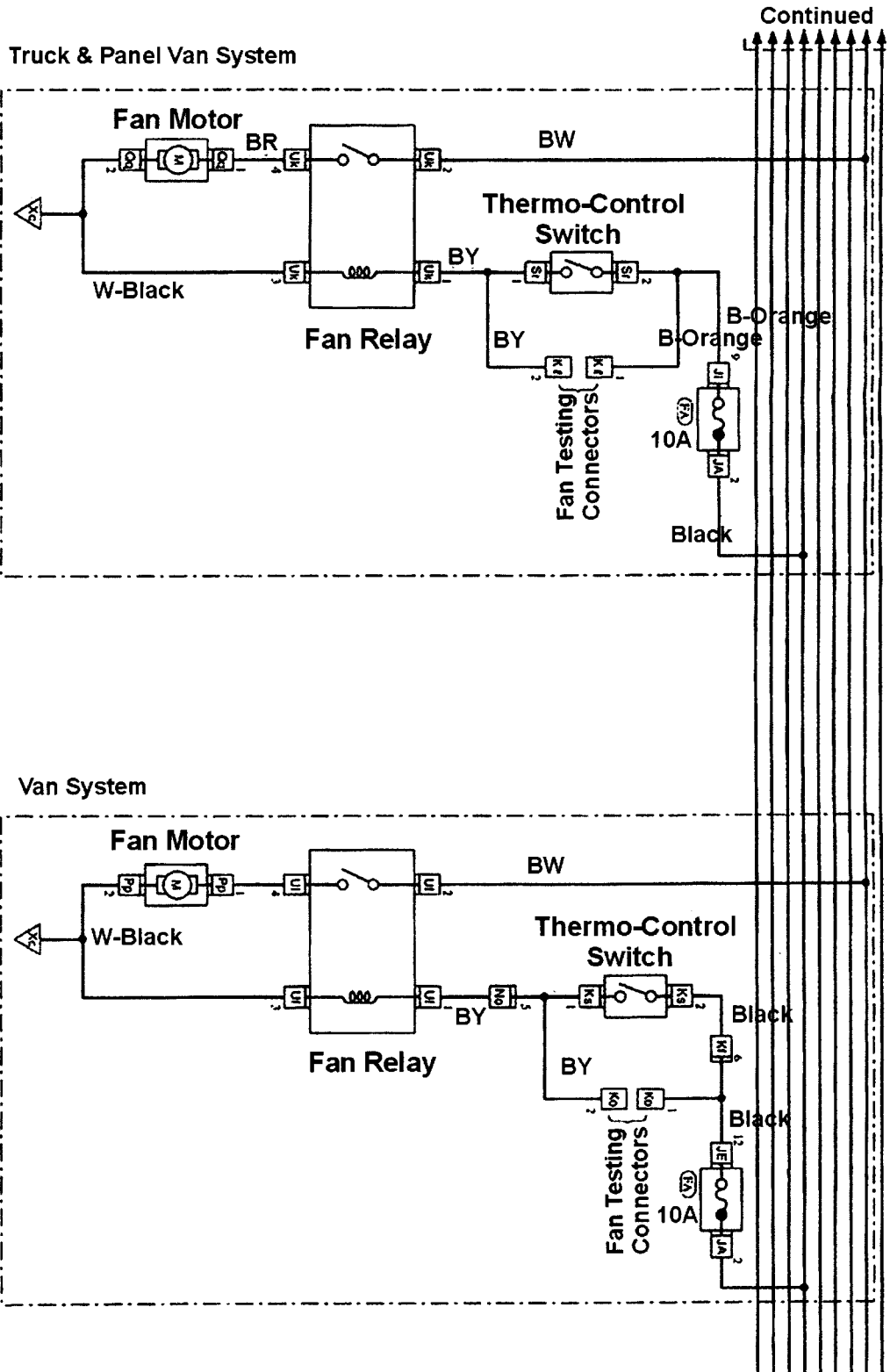

Part Time 4WD System (Hi-Lo)

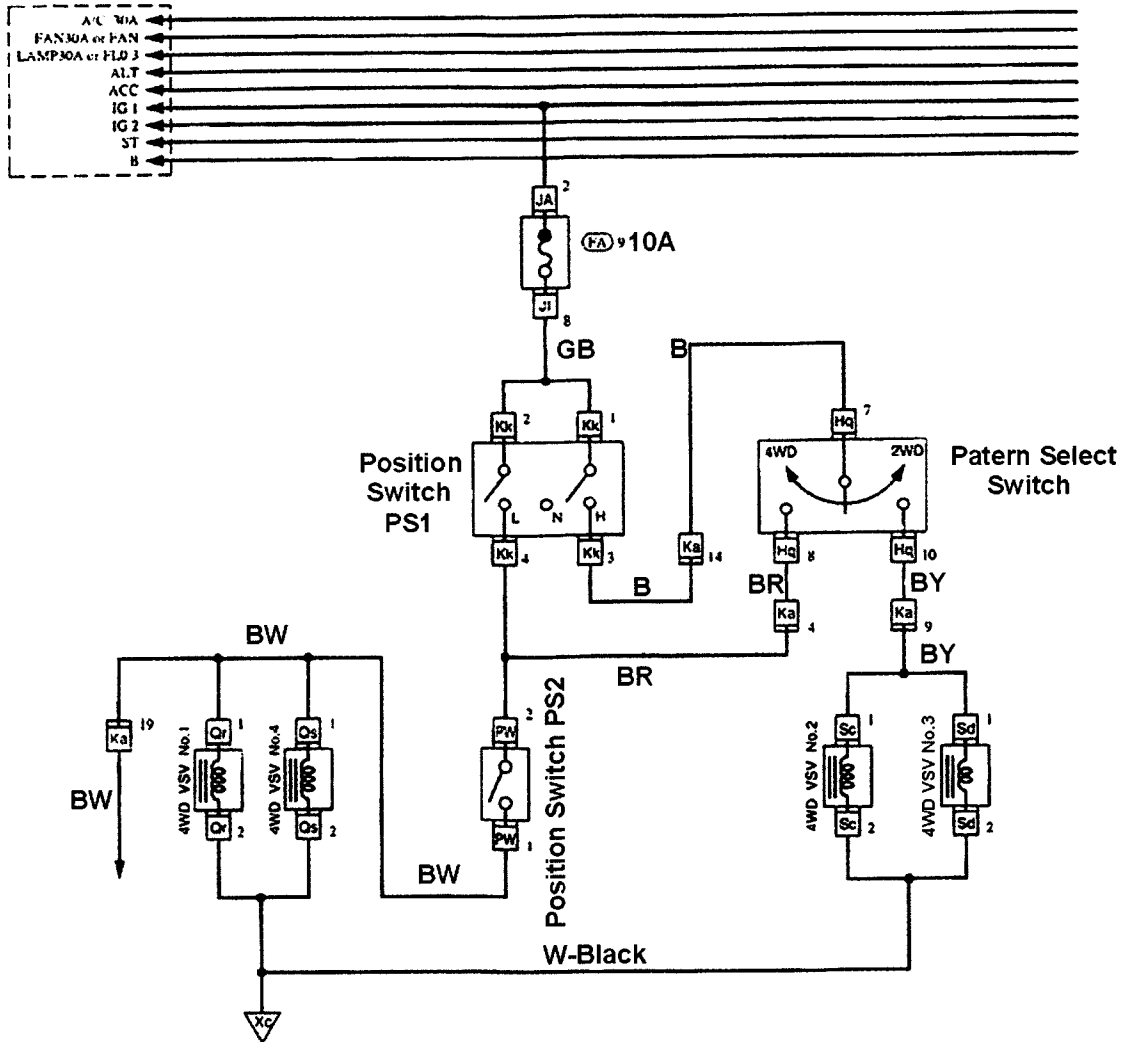

Connectors and Pin Numbers

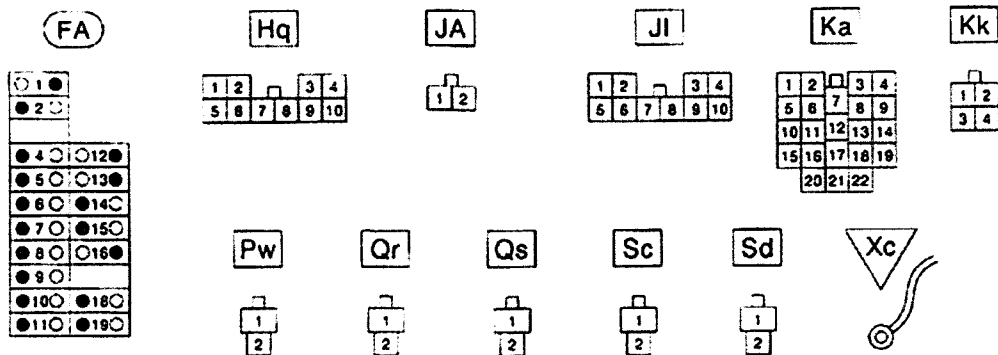

Dump Truck Circuit

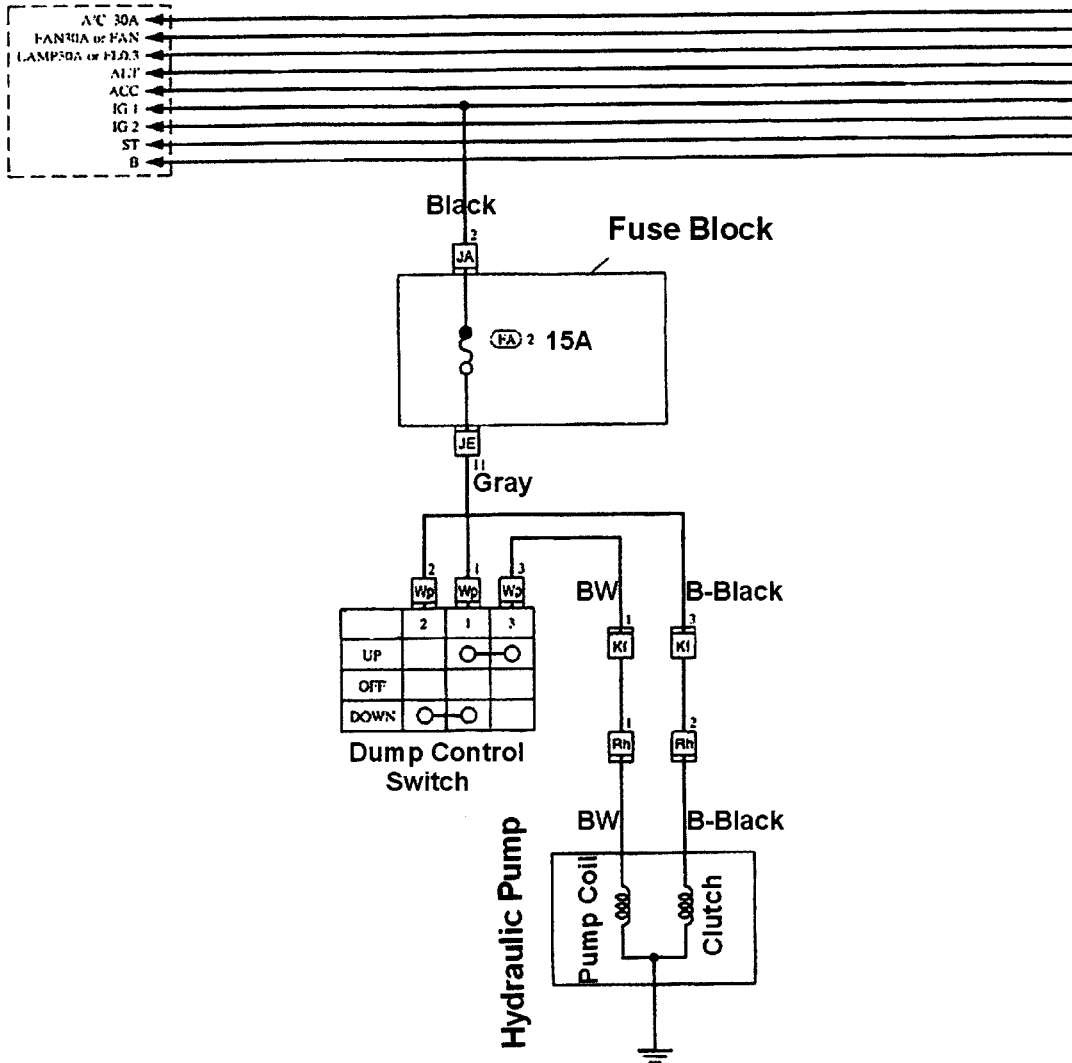

Connector and Pin Number Reference

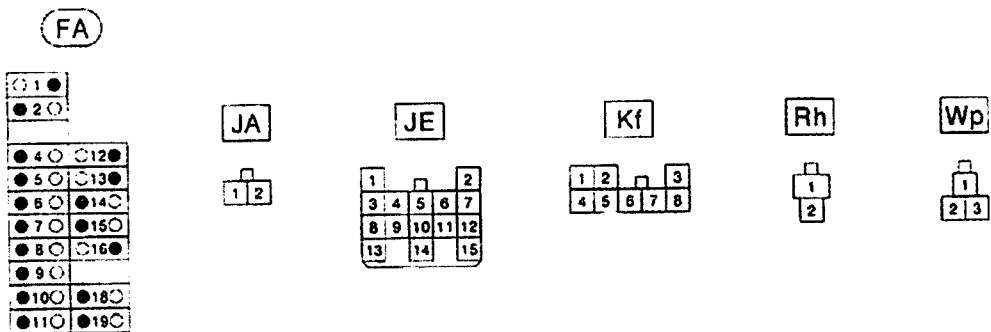

Fuel Injection Electronics Parts Location

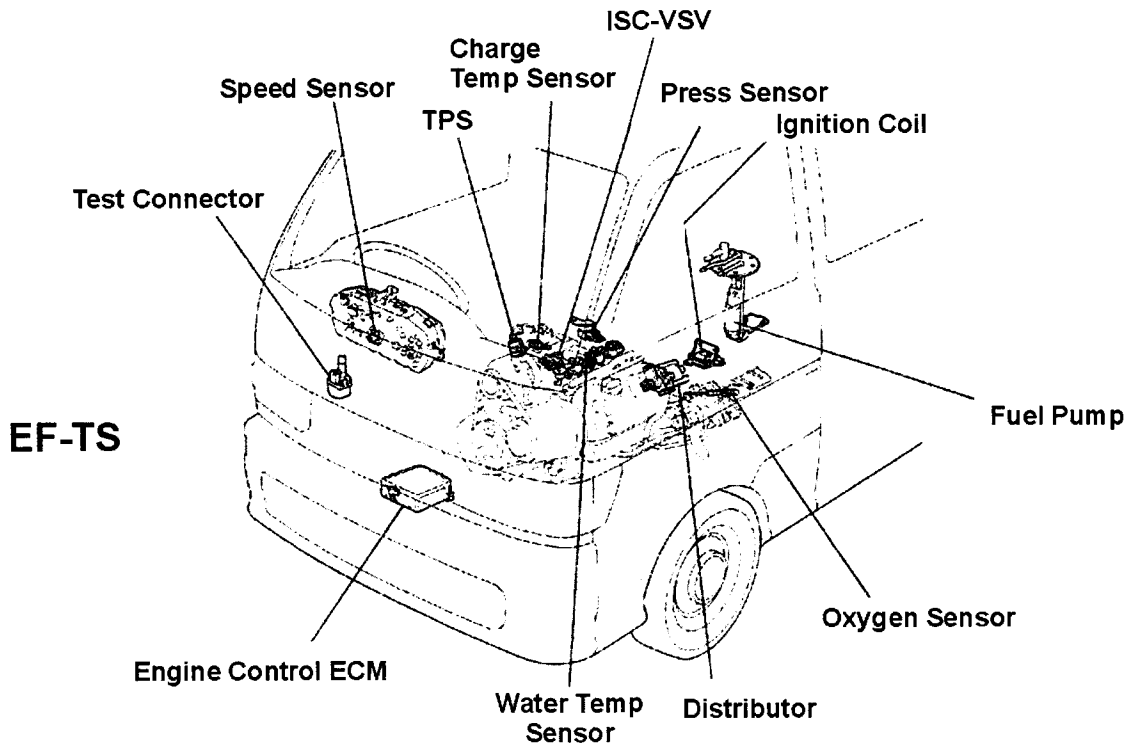
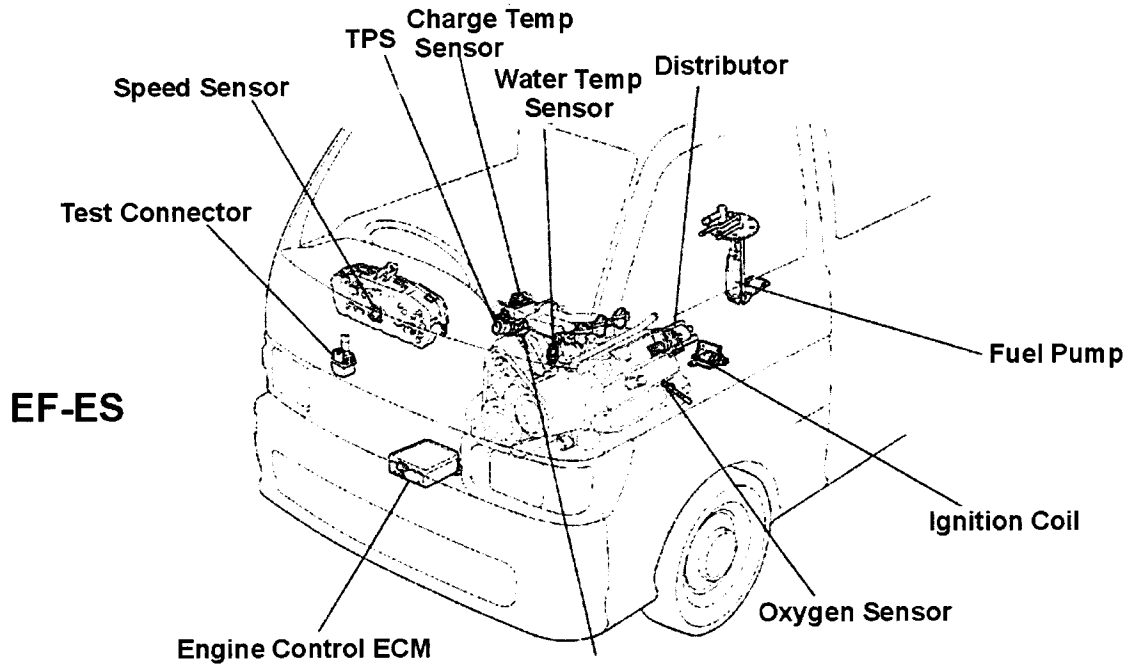

Engine Control Computer Fuel Injection

EF-ES

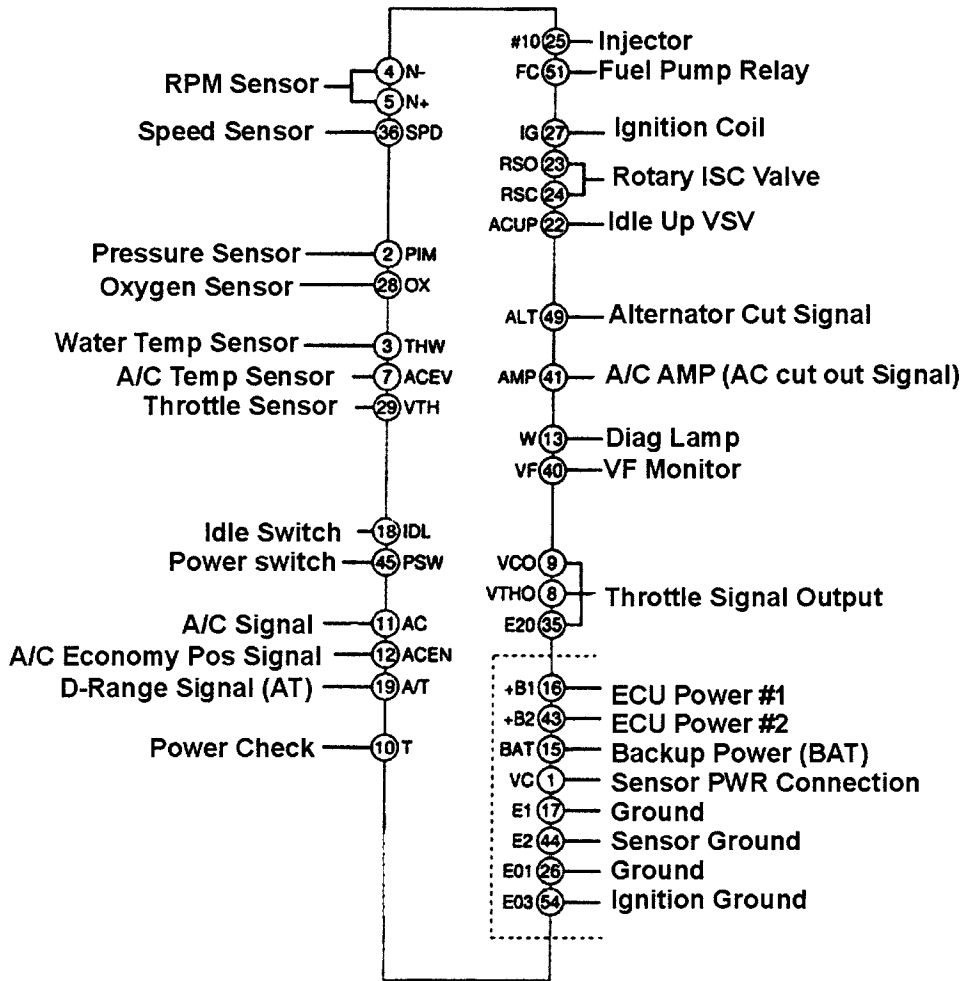

27	26	25	24	23	22	21	20	19	18	17	16	15	14	13	12	11	10	9	8	7	6	5	4	3	2	1
54	53	52	51	50	49	48	47	46	45	44	43	42	41	40	39	38	37	36	35	34	33	32	31	30	29	28

ECU Computer Connector Pin Guide

Engine Control System

EF-ES Series

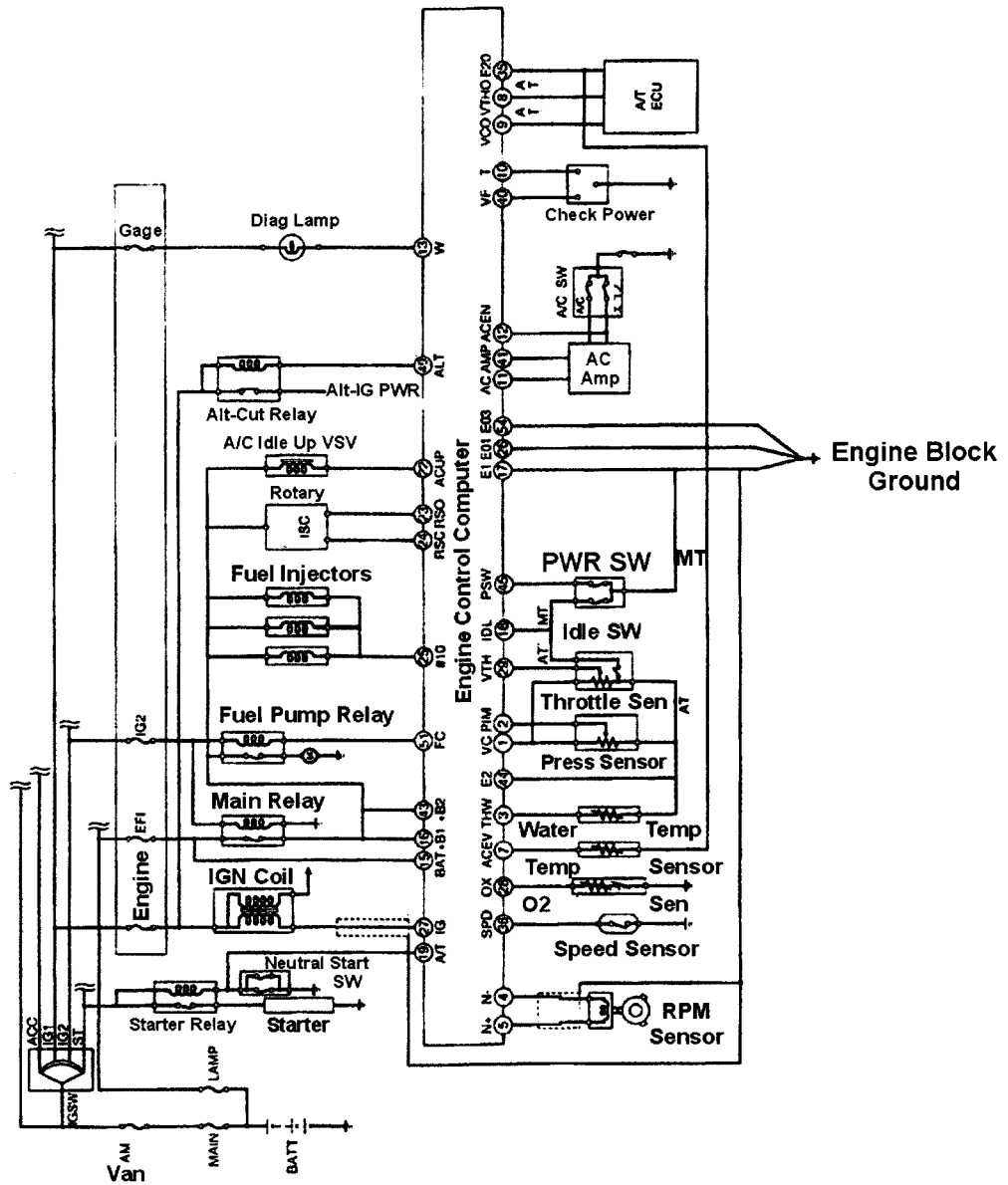

Daihatsu
HiJet Series

Please look for our other fine publications on Japanese Mini Trucks!

Suzuki-Honda-Daihatsu-Subaru-Mitsubishi-Others

For More Information Please Visit Our Sites or Call below

USA-Canada
(All Customers)
Red Top Auto
US DOT & EPA Registered Importer
www.dreammakersauto.com

For RHD Imports and Japanese Mini Truck Dealer Supplier
Call 1-239-980-400

Thank you!

Daihatsu

HiJet Truck and Vans

Full Electrical Diagrams

1. Main Power Circuit
2. Ignition and Emission Control
3. Starter & Alternator Power Circuit
4. Electrical Connector Locations and Pin Numbers
5. Diff-Lock MT Transmission
6. Stop Lamps, Brake Lights, Room-Dome Lamp Circuits
7. Tail Lamps, Clear Lamps, Licence, Meter Panel, and more
8. Headlight Circuits
9. Turn Signal, Hazard, Horn Circuits
10. Radiator cooling Fan Circuits
11. Part Time 4WD (Hi-Low) System
12. Dump Truck Circuits
13. Fuel Injection System EF-ES & EF-TS

2WD 4WD

HiJet Pickup & Van

660cc

V-S100

V-S110

V-S120

V-S130

V-S140

**Truck
Van**

Troubleshoot Your Electrical System
and fix broken or missing Circuits!

ID: 3575890
www.lulu.com

James Danko