

STALWART IS[®]



ANTI-RAM BARRIER + SECURITY FENCE

Stalwart IS unites the *strongest security fence available* with the *most widely used anti-ram perimeter barrier*. The appearance of Stalwart IS is a *great visual deterrent* that delivers strength and fortitude for keeping any assailant from easily breaching the perimeter.

DESIGN INTEGRATION

The Stalwart IS framework is a raceway for wiring, conduits, and/or security cabling required around the perimeter of a project. This integrated design eliminates the need for costly trenching and boring becoming a value added solution for perimeter security upgrades.

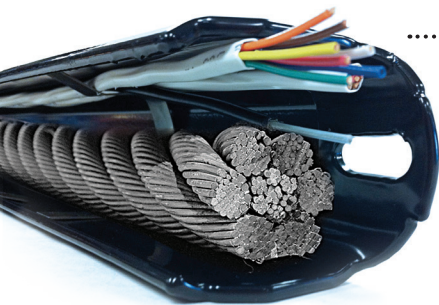

(inside of rail shown / view from protected side)

When installing these security elements use Stalwart IS as a platform:

- Communication & Video Cables
- Intrusion Detection / Fiber Optic Cables
- Access Control Wiring
- Conduits
- Anti-Ram Cabling (Stalwart)

PRIMARY APPLICATIONS

- Military Sites
- Petroleum & Chemical Facilities
- Power Plants & Substations
- Government Facilities
- Airports
- Ports of Entry
- Data Centers
- Water Treatment & Storage



AMERISTARFENCE.COM | 888-333-3422

ASSA ABLOY, the global leader in door opening solutions

AMERISTAR[®]

ASSA ABLOY

STALWART IS[®]

ANTI-RAM BARRIER + SECURITY FENCE

2.75"w x 14ga PALES | 2" x 2" x 11ga RAILS | 3" x 2.75" x 12ga I-BEAM POSTS

Bollard sizes & cabling vary based on desired crash rating

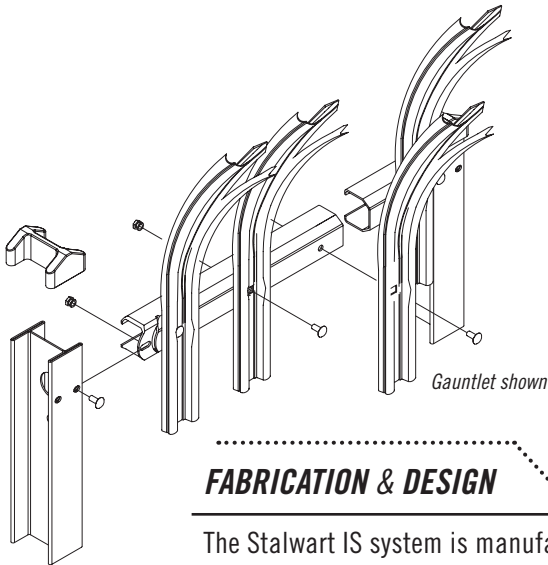

STYLE OPTIONS

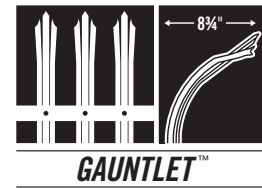

FABRICATION & DESIGN

The Stalwart IS system is manufactured of high-tensile steel and is pre-galvanized inside and out for superior corrosion protection. Each component has been roll-formed into a unique profile that yields significant strength properties to encourage an anti-climb and anti-cut perimeter barrier. Each connection point of the Stalwart IS system is secured with tamper-proof fasteners providing the highest level of security and versatility.



PERMACOAT™ PROTECTIVE FINISH

Ameristar's production facility uses a state-of-the-art polyester powder coating system that provides a durable and scratch resistant finish. This PermaCoat process has a dual-coat finish, which yields the best results for durability and weathering in the industry. These finished components can endure over 3,500 hours of salt spray testing; proving our claim of long-lasting durability.

CRASH RATINGS

Stalwart IS offers multiple anti-ram ratings engineered and tested to meet ASTM F2656 standards. Each installation can be designed with most the appropriate stand-off distance from the assets.



#9807 | REVISED 06/2014



FENCE PRODUCTS

TO PLACE YOUR ORDER CALL 888-333-3422

VISIT AMERISTARFENCE.COM